

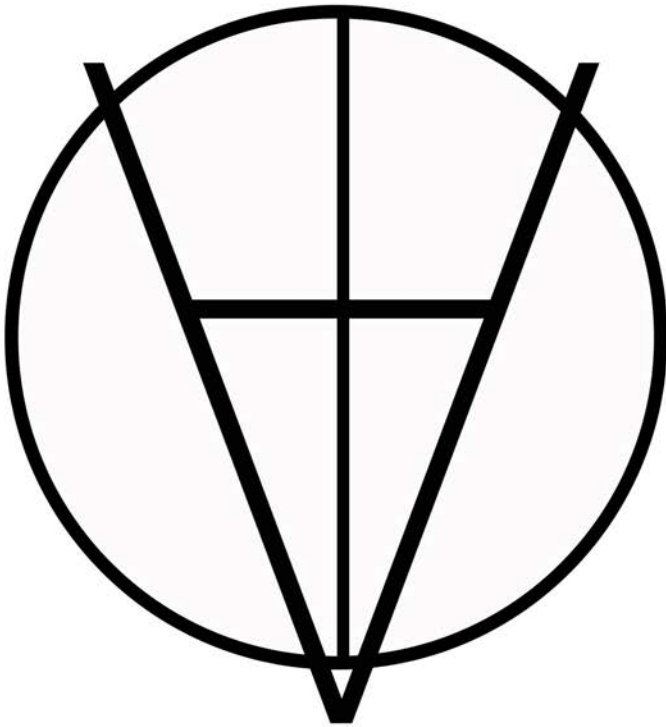

DVARK

Dark Vrts Research Kollektive

FIELD REPORT #1



The Dark Vrts Research Kollektive

is a multidimensional ritual space existing betwixt academia and the arts. It is composed of researchers, artists, designers, performers which explore occultural practices, fortean geographies, paranormal resonances, psycho-physical enchantment, and general high weirdness. It came into existence in the rooms of [REDACTED] but it is independent, unstructured and oblique. It was born in the late 2022, but it gathers the lifelong efforts of its participants to explore the most peripheral oscillations of the real, through the practice of the arts and of creativity.

For the **DVRK**, distinctions such as material-imaginal, perception-illusion, virtual-actual, true-false are meaningless, as they strongly believe in the non-dualistic, boundary-breaking power of occulture. The **DVRK** intends to trace and share new paths in magic techniques and spiritual technologies, to explore their potential of communion, subversion, and change. Where are, today, our possibilities to go upstream, against, sideways? How to subvert, reinvent, misuse contemporary hegemonic discourses and technologies? What rhythms of new collective dances can we find, if we look with positivity and care to what mainstream moralism has called the 'dark arts'? These are some of the questions that move us, in an attempt at making our everyday world bigger, more diverse and stranger. \forall is a mathematical symbol meaning 'for all', 'for every': we strongly believe in the communal dimension of such fringe fields of knowledge and practice. The **DVRK** shall be the node of a network, connecting communities through inclusion and participation.

What you're looking at is the first field report of the group, expressing the first months of its existence. Most of the contributions are incomplete, obscure and provocative, and they might find either resolution or more confusion in the next publication. The **DVRK** acts here as the Fool, both expert and naïve, neither beginning nor ending.



CONTENTS

WRITING

Jacopo Bortolussi &
Matteo Polato
*Real Engine: Towards A
Praxis Of Virtual Magic*6

Mary :O:
Randonautica For Kids16

Hannah Singleton
Pendle Witch Trials22

Damon Bannister
Gates of Hades29

Fabrizio Cocchiarella
*Embodied Engagement
with Funerary Shaped
Spaces*34

Rev. Dr. Dave Mee
*A Report On Sightings
From 155.133.130.207*38

Babar Suleman
Isle of Sirens49

Chris Gladwin
Biokinetic Mantra52

Julian Holloway
.....58

Antony Hall
*Experiments In Perceptual
Deprivation:
The Mirror Gaze
Experiment*62

IMAGES

K Craig - Covers, 4, 28, 35, 61

Ian Morris - 15

Micheal England
Driftwood Witches - 21, 45

Mack Manning - 25, 26, 27

Raz Ullah - 36, 37

Agnieszka Piotrowska
The Rose that is Time - 46, 47, 48

K Craig - Design



**REAL ENGINE
TOWARDS A PRAXIS
OF VIRTUAL MAGIC**

JACOPO BORTOLUSSI
MATTEO POLATO

It all started with Dark Souls. While indulging in our cherished activity of wandering among the ruins of the rural countryside near our hometowns, we had the distinct feeling of a kind of resonance between the ways we explored and interacted with those places, and the ways we experienced space, stories and symbols in the worlds of the Dark Souls saga. As we kept investigating this sensation through several such excursions, we realised that what had started as a feeling was gradually turning into a practice. It was not merely imitation: we were not just making our way through these ruins as if they were the stage of a videogame. Rather, we were attempting to glimpse at a hidden aspect of those places, an aspect that digital and material places seem to have in common - namely, an inherently weird virtuality. In a sense, it was those games' peculiar sense of place that taught us to pay attention to alternative patterns of interconnectedness hidden beneath our routine spatial experiences, and that those patterns could be reclaimed through practice. By that stage, it was not about Dark Souls anymore. As we insisted with this practice, places that were familiar in our everyday life started gaining a new kind of familiarity, strange synchronicities took place at each trip, new configurations of the relation among things in those environments took shape, and a new lore emerged between us looking at those places, and those places revealing themselves to us in unexpected ways. It was what we came to think of as a process of discovery/creation, and this text is our first attempt to propose some methods to enact it. But before we proceed, we should lay down some thoughts that we think will help us to convey the readers what we do.

Gaming remains at the centre of our attention. In particular, the phenomenon of retrogaming is a useful place to start, especially when considered from the lenses of horror. Many look back at older seasons of videogame history – particularly the so-called 4th and 5th generation – with a sense of unsettlement and awe. Among horror fans, early survival horrors such as Resident Evil, Silent Hill, or Alone in the Dark are often claimed to trigger deeper fears than their contemporary equivalents developed in Unreal Engine technology and so forth. Ironically, however, when it comes to retrogaming, the horror genre does not stand on the podium of the weird. In fact, games ostensibly aimed at children and completely extraneous to any horrific connotations such as Pokémon Red/Blue, Super Mario 64 or Zelda Majora’s Mask – to name just a few – gave life to widespread urban legends and creepypastas, marked by a history of cursed cartridges, mysterious hidden content and strange psycho-physiological effects. While these phenomena are generally addressed through the political reading of the working of nostalgia and its hauntological effects under late capitalism, we believe that at the core of this there is something specific to that season of games itself. For us – or at the very least for how we experience playing those games ourselves – the reason why they feel so strange lies on the fact that they reveal something beyond games. That is, in their limited tiles and collisions’ interactions and bare polygonal models, they emphasise all the more how reality bears an inherent virtual dimension. In other words, just as it was argued how early cinema used to startle viewers not for the content it showed – say, a moving horse – but because it made viewers see for their first-time movement itself, likewise those games seem to keep startling players by letting them glimpse at interactivity itself: they unsettle as they trigger an awareness of the irreducible weirdness and apparent

irrationality of the potential interactions which virtually exist around ourselves. In this sense, the act of gaming allows the drawing of weird cartographies of the real, which, if followed in the material world, could expose a series of agential networks commonly cloaked under the disenchanted, formal/causal framework of modernity. Indeed, as the demon in *misfortune.gb* tells the players before locking them away forever: "I exist within the very fabric of reality".

But acknowledging virtuality itself does not necessarily lead to horrific effects; in fact it can do quite the opposite. This leads us to our next consideration. Since the inception of the videogame medium, mainstream moralism has relentlessly warned us about the risks entailed in playing too much videogames: these lead - their argument goes - astray from reality, into a virtual world which is opposed to the real one; the more time one spends there, the more one gets numb from the things of the real world. Ultimately, alienation sets in and, given enough time, it will drive the player into madness. The origin of these concerns lies on a fundamental and widespread ontological bias which operates a binary opposition between The Real and The Virtual, almost as if the dominant videogame debate took too literally the perennial metaphysical dispute between realism and idealism. However, what seems to escape the advocates of The Real is that, as mentioned before, reality itself has an immanent virtual dimension. This is not to say that reality is an illusion, but rather that virtuality cannot be separated from the constitution of reality as a somehow autonomous and discrete category. The virtual and the material are immanent to one another, just as maps and territories are ontologically bound together. From this perspective, videogames - perhaps more powerfully than other forms of art because of their radically digital

nature - represent tools that can be used as epistemological resonating filters to emphasise the virtual stratum of the ontological spectre of the real. As they allow us to glimpse into virtuality itself, they also allow us to trade with the agencies which dwell in it. And emphasising the virtual as but one attribute of the real helps us to overcome that rigid dichotomy which tends to stress reality as a domain of pure matter with no inherent meaning, a disenchanted world in which imagined things do not enjoy the same position in the ontological hierarchy of all things. What follows is our attempt to outline an ethics of virtuality, employing the act of gaming as an 'attuning device' to get exposed to the multiplicity of alternative networks of agencies embedded into the constitution of the everyday. We call to resist both an overemphasis on the material, which can easily lead to nihilism, and an overemphasis on the virtual, which can in turn lead to conspiracy, and to entertain

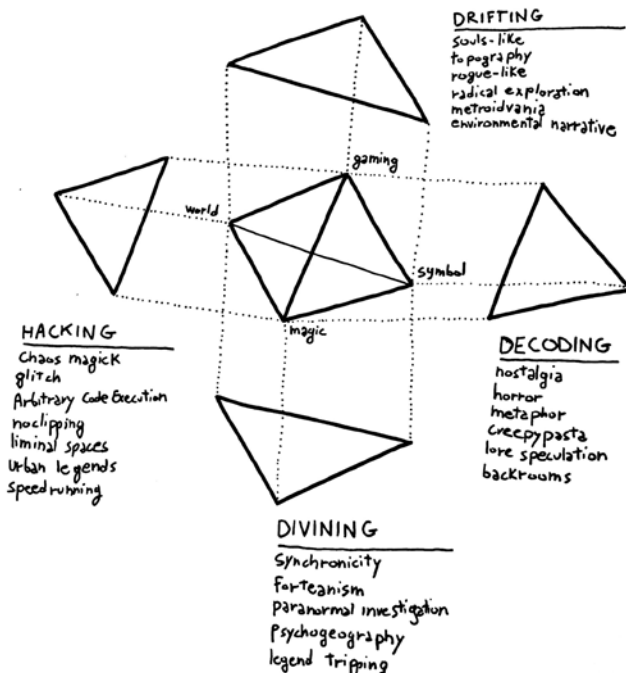

instead the idea of a dynamic feedback between the two. We name this process Real Engine.

Real Engine is a process of both discovery and creation. These two are not autonomous vectors, and do not represent discrete and oppositional tendencies. They are rather mutual and inextricable impulses, and shall be reflected in a posture of simultaneous activity and receptivity by the Real Engine practitioner. We recognised four main energy sources in Real Engine, which we shall name gaming, magic, world, symbol. These sources are in a constant state of resonance among each other, hence our choice of the tetrahedron as the shape to represent the engine. Such shape shall not be geometrically conceived in terms of symmetry, rigidity and immutability, but as a partial impression of a fluid system constituted of elements in reciprocal and recursive interaction. The four sources are connected, but not bound by hierarchical, chronological or causal orders. The resonance between gaming, magic, world and symbol produces fields of exercise that represent different aspects of Real Engine as an operative praxis. We provisionally called these fields drifting, decoding, divining, hacking - more fitting names may well be found. We identified each of these fields as expressions of a series of already established practices, tendencies and moods. As they tend to elude systematic categorisation, many of these could partially overlap, morph into each other, or belong to more than one of the four fields. We understand Real Engine as the process of weirding the real that takes place when these fields are in resonance.

As said, Real Engine is praxis, and as such it expresses itself through doing things in space. Go somewhere, preferably an ordinary, everyday place, which is not already charged with established collective lore or

mythos: in Real Engine, every space is virtually haunted. The place does not need to resemble a specific videogame: it is not a matter of visual aesthetics, but of applying a specific gameplay mechanics to the interaction with the place. This could be, for instance, a souls-like exploration in search for interconnecting shortcuts, a rogue-like reiteration of the same path aimed at learning new elements at each run, a metroidvania process of reaching initially inaccessible areas thanks to newly acquired knowledge, and so on. As a practice aimed at honoring all agencies, it must always respect and care for the needs and wellbeing of all entities, may these be human or non-human. The procedure should thus not be approached as a form of "as if", which would result in a reification of those mechanics forcefully superimposing them on the material world, but as a form of trading with the place as a way to reclaim the enchanted forces that inhabit it. For this reason, avoid to focus on causal/formal interactions and connections, and have trust instead in synchronistic relations. This allows to attune to the networks of non-human, virtual agencies that stand at the foundations of the interactive and meaning-making workings of videogames, which are yet neglected by the conventions that govern the ordinary everyday.

Search for things betwixt; go out of bounds; speedrun across different environments by taking advantage of glitches and bugs; speculate on seemingly irrelevant details of the environment as crucial elements of a mysterious lore; figure out what is quest and what is cut content; notice strange affordances that would give you hints on how to progress; talk to NPCs, as they might have important story clues, and kindly accept sidequests from them; take into account similarities, recurrences in objects, shapes, symbols, concepts, no

matter how fortuitous, just as the reuse of assets in videogames can express relationships and common histories between distant areas of the map. Try these things and more, and the real will gradually begin to reveal itself in its enchantment, ambiguity, and weirdness, a more diverse world that resists utilitarian dualist oppositions. Almost as a form of magical practice, you could create the conditions for things to behave, mean, affect and be affected in different and original ways, because you would be tapping into the infinite potentialities of the real virtual. Finally, if you have time and patience, try to develop your own videogame based on your adventures, and then reintegrate it into the process of Real Engine. Use it as additional map or compass to create a positive feedback to amplify and unlock further potentials, and let the exploration be guided by the game itself. We tried to do it, and it works. We called it The Fair and it runs on GameBoy, a console which can easily be used as a portable map. When we drift in the rural countryside near our homes with its aid, we now enter a new and weird zone.



<https://yamikurae.itch.io/the-fair>

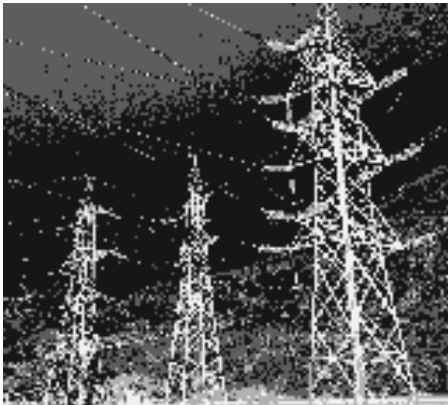
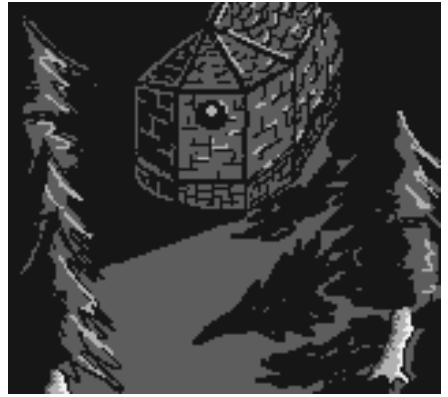



key³



RANDONAUTICA
FOR KIDS
or
HOW TO TAKE OFF THE STARS
- PART 1 -

by Mary:O:

The Asking

I've always been into divinatory systems.

From the I Ching to ancient roman geomantia, from early childhood superstition pattern revelation to weird numeric superposition, they helped me in the crucial parts of my life. The rule for asking was simple, "ask only when it's time to do it", as a wise man once noted that it's irrelevant to ask daily for a response, the system work just once when it's the right moment. And the moment came rather playfully, coming to me all so rightfully in september MMXX, while processes long buried in the drowsiness of the quarantine were slowly re-emerging and re-activating themselves.

Randonautica was the real thing out there in those days.

I came to that thanks to magick friends, always prone to revive (unconsciously or not, they know it) my seasonal syncrostorms.

My 6 years old daughter asked me to try it after seeing a video on youtube about some silly and effortless randonautica exploration.

So i told her that, in order to make it work, it was key to have an intent, and to formulate the right question.

"So what we want to find out?"

"I want to find a deamon!"^o

"EH What? You wanna find a deamon?"

"Yes. But 'A good one'. A Good Deamon That Helps Jesus"

The Searching

After a short bike ride, we had to cross a dry ditch. The area indicated by the app was in the middle of a cultivated field. We walked along a wine yard, and tried to reach the exact point at the centre of the “zone”. It was nothing of interest there, only tiny plants emerging from the dry soil.

I told my daughter that it was possible to have nothing left from the searching but “a nice adventure together” at least.

However, if you’re used to the randonautica experience, the zone of interest to the intent is not just at the centre. Its radius of “effect” is variable, so we had another 30 meters of radius to search over.

As we were retracing our steps, we came along a fench and tried on our left. There was a private backyard, surrounded by trees.

A feeling of “this is the place” was whispering in my mind as we reached the end of the path, hindered by the fench.

And then, we found them.

Under the trees, awed by our presence, a family of peacocks ran out from the bushes and hid away from our sight.

Our heartbeat was running crazy, as the encounter was both unexpected and abrupt for us and them.

“We found it!” cheered out my daughter.

“Yes indeed” I confirmed.

I knew we really found it. It was a sudden realization.

The first recollection that jumped in my head was a memory about the Yazidi’s Peacock God.

Further researchs at home confirmed the previous, but in a very intricate manner.

The Answer: Melek Taus or the fake peacock deamon

The Peacock god is the Yazidism superior being.

None is above him, as he is the most luminous one of the angels.

Misinterpretations of his role was fuelled by the IX century Islamism as Yazidis were persecuted as Satan's worshippers, and it's here that the transformation of the Peacock as a fallen angel begins.

Its name changes from Tawûsî Melek to Melek Taus.

If Tawûsî Melek refuse to bow after Adam to demonstrate its loyalty to the only One God, Melek Taus is instead guilty of its pride and arrogance, and suddenly associated to the Luciferian figure.

Lucifer, whose name means "bringer of light", install itself in the promethean current in a way. It's the post-divine human process of stealing the light of God (call it fire, consciousness, self-aware cosmo'singularity) and bring it to humankind both as a tool and a curse.

Just like the crown of thorns dripping blood drops on the soil below the cross, Melek Taus is then redeemed from its sins as "he wept for forty thousand years and collected his tears¹ in seven jars which he used to extinguish the fires of hell²".

We have to clarify that the Yazidi's spiritual tradition and cosmogonic lore is obscure and full of misconception due to its specific character of iniziatic and oral transmission of its content.

Therefore the construct of western appropriation of the original Tawusi Melek is evident as the web pullulates of unsourced material and juxtaposition of terms.

That is in fact what we were searching for.

Not the trueness of God, or a God.

But a construct, a deamon nonetheless, that helps Jesus to redeem the world with its tears, be the picture true to a tradition or not.

Just the picture in itself is the answer.

The Aftermath

What the picture led to after the discovery is more than funny and complicated, as I found out in the months and years after that Randonautica experience. Actually, it activated a synchronistic storm that led me to an unexpected journey, sailing around the red sea of apocalypse in search of the true name of the nameless stars to finally switch all of them off. But this is another story to tell.

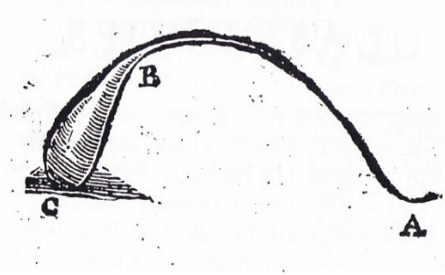

fig. 2

⁰The Italian word *demone* refers to both *demon*, *daimon* and *daemon*. From now on the term *daemon* will work as a pseudologism, in order to cover all its related meanings+, and to neutralize any polarization of charge. This is "*daemon hunting for kids*" after all!

¹I like to associate this image to the Arcangelo Sassolino's installation for Malta Pavillion at Venice Art Biennale 2022, in which plasma teardrops were dripping into water canisters.

²"Prince Rupert's drops are toughened glass beads created by dripping molten glass into cold water, which causes it to solidify into a tadpole-shaped droplet with a long, thin tail (see fig. 2). These droplets are characterized internally by very high residual stresses, which give rise to counter-intuitive properties, such as the ability to withstand a blow from a hammer or a bullet on the bulbous end without breaking, while exhibiting explosive disintegration if the tail end is even slightly damaged."³

³Reminder for the future self: here is the *key* to the whole operation. See related picture.



Triple Headed Wood Witch



PENDLE WITCH TRIALS

HANNAH SINGLETON

The Pendle witch trials saw twelve residents of a rural East Lancashire area accused of witchcraft, with ten found guilty at Lancaster prison and executed in August 1612.

Despite the trials occurring some 45 miles away popular imagination ties this history to the landscape of the moors and hamlets of the Pendle region, with the looming presence of Pendle Hill used as a visual motif in the retelling of the story as a contemporary folkloric tale. The witch is a cartoonish figure depicted in local tourism advertising, ghost hunts and souvenirs, yet there is also a memory of real trauma which haunts this landscape. My research explores this shift from the reality of innocent members of the public being murdered by the state to the status of the history as something more like legend and how





these contrasting versions are played out within and through the rural landscape.

Markers of the witch occur throughout the Pendle region, with the location offering the opportunity to remember and reperform the histories of those accused where there is no set memorial of a grave. Tourists

walk the waymarked route from Pendle to Lancaster 'in the footsteps' of the accused in an act of mourning which recalls the rural traditions of the corpse road (Dunn 2020). The bodies are absent but reoccur throughout the landscape in sculpture and iconography. Visitors are asked to embody this history and reperform the memories.

Tourists lay flowers at the feet of Alice Nutter's statue outside her home village of Roughlee before visiting the nearby museum and giftshop in Barrowford where tea towels are sold mapping the key sites of the history, including that of the executions in Lancaster. Books giving historical accounts of the trials are sold alongside fridge-magnets and miniature broomsticks.

Artists and storytellers have sought to 'make present' these absent bodies within the landscape particularly since the 400th anniversary of the trials in 2012. Prior to this many of the retellings and associated imagery were framed as folklore, divorced from the factual and political context of the history, in a manner which paralleled the

denial of witch hunts as violence against the othered female body (Federici, 2004). Recent artistic interpretations have reframed accounts through interventions within the landscape itself, acknowledging the persecution of witches as linked to place in Pendle and also the wider implications of land ownership and capital in these histories (Federici, 2004; 2018).

References

Dunn, S. (2020). Folklore in the landscape: the case of corpse paths. *Time and Mind* Vol. 13 Issue 3, pp. 245-265.

Federici, S. (2004) *Caliban and the witch*. New York: Autonomedia.

Federici, S. (2018) *Witches, witch-hunting and women*. New York: Autonomedia.



revealed her thighs and stockings tops, pointed breasts under a day-glo blouse.

She tottered round to the far side of the bed and undressed, heaving the clothes into a wastebasket. When she was naked she slipped under the covers. She stared up at the Rogers and Astaire, and at the ceiling, and at her own, partly to still him, and partly to see what the remainder of the night and early morning would be like. She was aware in his fever of the

...and a concrete barrier, but the metal crash-bar screened the island from the drivers. The high mass of three traffic indicators rose from concrete caissons built into the shoulder of the road.

Maitland turned as an off-line coach passed along the motorway. The passengers on the upper deck gazed for Zurich, Stuttgart and Stockholm, sat stiffly in their seats like a party of mannequins. Two of them, a middle-aged man in a white raincoat and a young Sikh wearing a turban on his tall head, looked down at Maitland, searching his eyes for a few seconds. Maitland returned their gaze, but was not to waver. What did they think he was doing there? From the car he saw that his Jaguar might well appear to be undamaged, and that he might assume that he was a highway official of a traffic engineer.

Below the overpass, at the eastern end of the island, a wire-mesh fence sealed off a triangle of waste ground from the area beyond, which had become an official municipal dump. In the shadows below the concrete spans were several dozen furniture vans, a stack of stripped-down metal boats, hundreds of green and untreated metal refuse. A quarter of a mile to the west of the overpass, visible through the fence, was a residential shopping centre. A red double-decker bus circled a small square, passing the striped awnings of multiple stores.

Clearly there was no parking space other than the embankment. Maitland found the keys in the ignition of the instrument panel, the Jaguar's trunk. The chances of a wandering hand finding the car were slight: the trunk was sealed off from the world around it by the high embankment on its sides and the wire-mesh fence on its third. The compulsory landscaping had it to be cut out by the contractors, and the original contents of the shabby car, its rusting cars and coarse grass, were still untouched.

Holding the handle of his leather overnight case, Maitland tried to lift it from the trunk. He found himself fainting from the exertion. The blood had drained instantly from his head, and the minimum circulation was being reduced. He put down the case and leaned weakly against the side of the trunk.

In the middle of the rear wheel-housing Maitland stared







Gates of Hades.wav

YOUR KIDS ARE NOT GETTING HIGH FROM LISTENING TO AUDIO

So says an article from WIRED in 2010,
the height of the audio-drug panic.

Most other widespread reports
reached a similar conclusion.

So why - distributed on message boards and early YouTube
- are there dozens of videos of users contorting to break
their trance? Fear through sweat and convulsions? Shared
experiences; walking across a bridge; falling a great height;
the fire; the face. An experience like the Gates of Hades
repeated and spreading
through minds and message boards.

A desire to explore worlds delivered via audio drugs, or a
desire to feel a sense of belonging and ownership of the
fabricated experiences of others; either way, an idea is
transmitted through the power of
an .mp3 in a dark room.

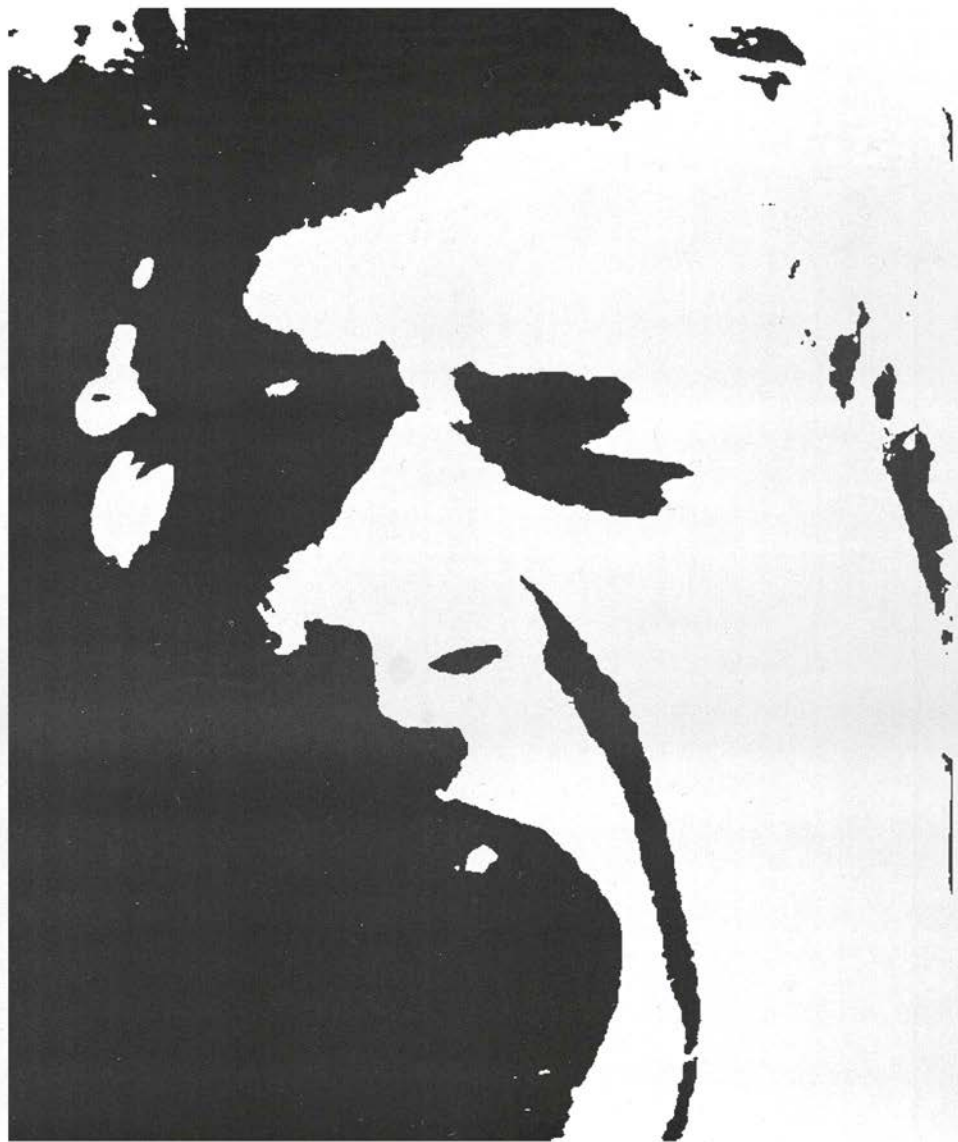

————— GATES OF HADES —————

pitch black if you will.

and I started feeling something move around me
and breathe on me.

falling into a bottomless pit.

a bright light shined down on me
and again I felt peace.

never do this one again. well, anytime soon.



Gate of Hades



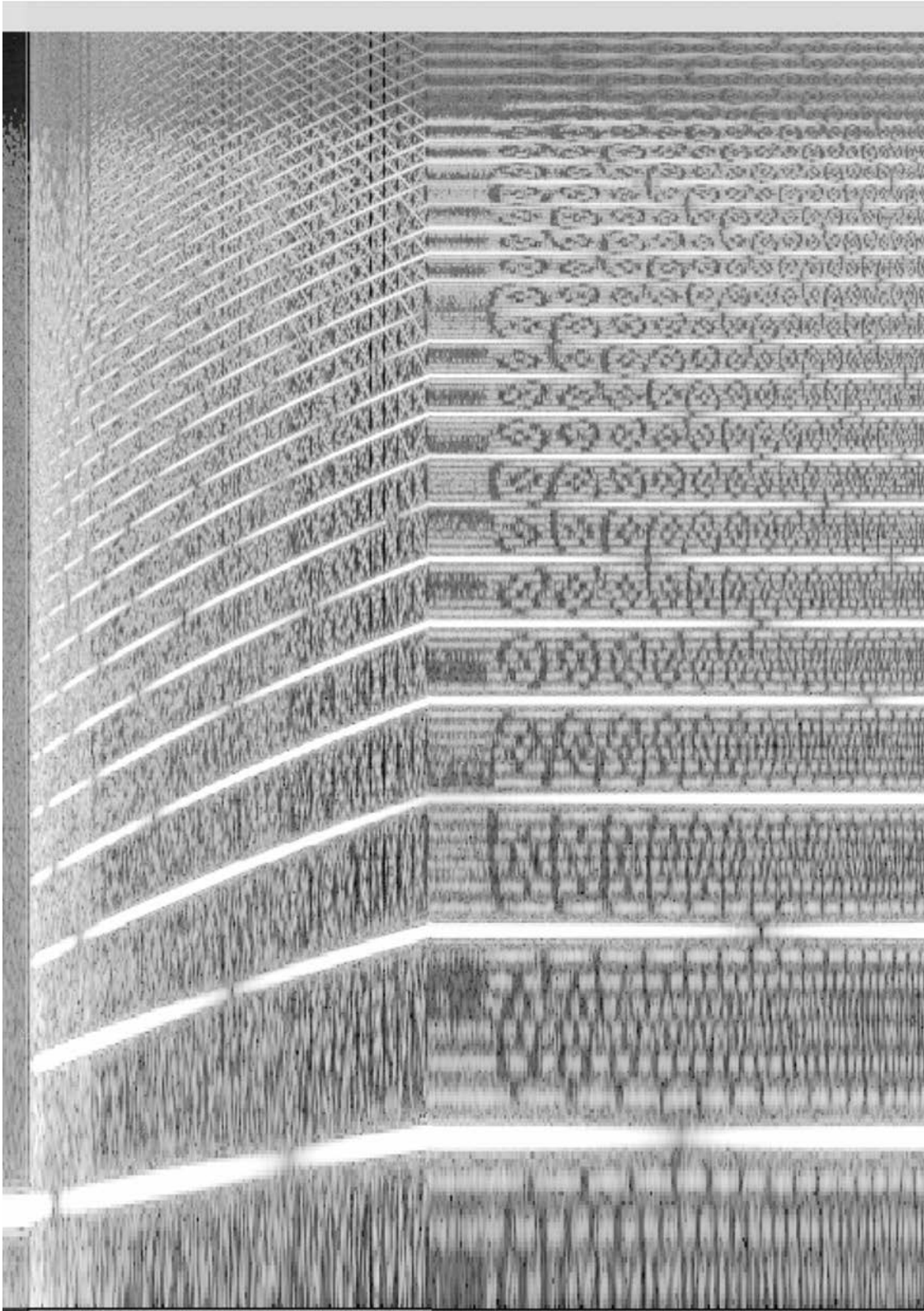



Embodied Engagement with funerary shaped spaces

Part of ongoing social research into the design of 'infra-ordinary' experience that translates critical aesthetics into fictions that are assimilated into a world of ideas and experience-based provocations around self, object, architecture and place.

Through engagement with body shaped vessels the audience is invited to contemplate mortality as a form of *memento mori*, a divination device designed to encourage conversations around death, cultures of belief, medical/ scientific myths and synchronous rumours. Using estrangement to open space for critical discussion, the experience explores the link between mental lives and lived experience, an aid to mental health through transpersonal cognitive empathic connection.

Fabrizio Cocchiarella



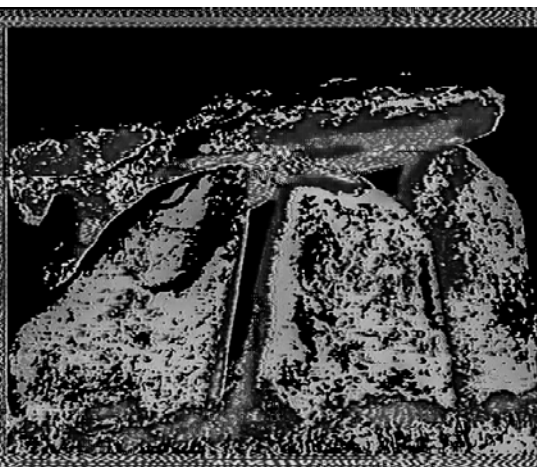



A REPORT ON SIGHTINGS FROM 155.133.130.207

REV. DR. DAVE MEE, COMPUTER SEANCETIST

This has gotten out of control. The server is running out of disk space, but it's doing *nothing*. I copy-and-paste a single-liner from the web to find which files are using the most space

```
sudo find / -type f -exec du -hs {} \; | sort -rh | head -n 5
```

Amongst the database stores and indexes is a system log that is magnitudes larger than any other file - `/var/log/auth.log`. `var/log` is where log files live - the records of changes and system events that may be of interest when auditing and reviewing activities of a machine, and in this directory `auth.log` is a record of all the login attempts to the machine, whether local or remote, successful or not.

And there it is:

```
-rw-r----- 1 syslog adm 4617927368 Jun 15 17:04 /var/log/auth.log
```

Four and a half *gigabytes* of records of uninvited visitors, of attempts to gain entry to the server - but there's only one valid login to the machine, and it's used once a week, at best.

```
cat /var/log/auth.log | grep "Invalid user"
```

3,335,237 failed login attempts since the server was last restarted, exactly a year ago - one every ten seconds, on average. Every single attempt intrinsically futile, as the server is set to ignore login attempts using passwords.

These are *automated* login attempts. No human would continue to try to bypass the security of this machine, but *something else* is compelled to try, continuously, unfazed by failure or futility. Jussi Parikka argues the internet has created a new domain of life, of software systems that breed, replicate, and mutate, mirroring aspects of the biological - viruses being the most commonplace, in both. The logs show their sophistication, presenting themselves innocuously as known human and software agents, masking their nefarious purposes. *Botnets*; groups of computers infected by the same code, programatically driven to spread their hidden infection to other machines.

```
sshd[22708]: Invalid user liang from 111.161.41.156
```

```
sshd[22713]: Invalid user ubuntu from 111.161.41.156
```

```
sshd[22715]: Invalid user frappe from 111.161.41.156
```

Unix systems are steeped in magical terminology - 'daemons' provide persistent and invisible system services, 'zombie processes' live in the system as running software fails to terminate properly and 'magic numbers' identify file contents. It's not for no reason that Hafner & Lyon's history of the early, mostly unix-based internet is called 'Where Wizards Stay Up Late', with its stories of technological priesthoods, invoking action from mathematical esoterica.

```
sshd[22719]: Invalid user tanya from 111.161.41.156
```

```
sshd[22721]: Invalid user testuser from 111.161.41.156
```

```
sshd[22729]: Invalid user ec2-user from 111.161.41.156
```

```
sshd[22731]: Invalid user log from 111.161.41.156
```

```
sshd[22737]: Invalid user zamdirzi from 82.207.8.194
```

```
sshd[22756]: Invalid user guest from 82.207.8.194
```

These attempts to gain entry continue, sometimes the same source presenting multiple names over and over; other times, the same username coming from a multiplicity of sources, as the botnets mutate and spread to different subnets. Botnets are a symptom of the exponential growth of network connected devices. They're programs designed to propagate to other devices over the net, exploiting known credentials and security flaws of unupdated devices to gain entry to and infect new hosts, spreading their coverage, awaiting encrypted instructions from their remote operators. They may infect home lighting controllers, modems - but their attempts to infect *general purpose* computing infrastructure renders their inbound attacks audited, thereby visible.

```
sshd[22760]: Invalid user student6 from 82.207.8.194
```

```
sshd[22764]: Invalid user gast from 82.207.8.194
```

```
sshd[22768]: Invalid user hello from 82.207.8.194
```

```
sshd[22786]: Invalid user firefart from 82.207.8.194
```

```
sshd[22807]: Invalid user test from 141.98.11.110
```

```
sshd[22809]: Invalid user test from 83.97.73.83
```

```
sshd[22811]: Invalid user hl from 194.110.203.131
```

```
sshd[22825]: Invalid user scj from 165.227.68.95
```

Whose are the accounts they are pretending to be? Why are these considered credible as ingress vectors? Some are known from historical device audits, and exist as legacies of hardware and software at the end of their support lifetimes, or which will never be updated by virtue of their producers' deaths or bankruptcy; they are assuming the identity of dead computing infrastructure, pretending to be them to living software relatives, repeating passwords that once were secret.

sshd[1123]: Invalid user lotte from 165.227.68.95

sshd[1127]: Invalid user jonathan from 191.8.166.185

sshd[1133]: Invalid user user from 43.134.178.78

sshd[1150]: Invalid user maintain from 211.221.173.228

sshd[1152]: Invalid user welcome from 191.8.166.185

sshd[1162]: Invalid user xindeng from 178.128.160.117

sshd[1166]: Invalid user mh from 182.59.139.27

sshd[1168]: Invalid user haris from 156.96.114.70

sshd[1172]: Invalid user noc from 191.8.166.185

sshd[1174]: Invalid user jenkins from 211.221.173.228

sshd[1178]: Invalid user steam from 146.190.234.134

Are these golems of the digital realm? Created from the computational foundations by technological priesthoods, imbued with names and secrets, summoning ambiguously dead credentials to grow ever more powerful. Their unthinking and literal following of instructions invokes the story of the golem of Chełm, inadvertently destroying forests when tasked to gather wood; these digital golems blindly attempting to access the same machines over and over, endlessly randomising credentials from an existing roster of stolen secrets.

The golems of lore are imbued with life by inscribing, inserting and chanting mystic phrases. Changing or reversing these phrases deanimates them. Botnets follow a command-and-control system, retrieving updated instructions from anonymous websites, giving their creators some control over their armies which have become undercover sleeper cells, like the instructions issued over shortwave numbers station broadcasts. But when the commands cease to come - the broadcasts end when their edict-issuing websites fall offline - the digital golems continue their existing instructions, replicating their infection across the internet with no further purpose or means of stopping. The golem becomes a Romeroan zombie, unable to die or change the behaviour it is driven by, consuming and spreading with no higher purpose. They can only be killed by destroying the digital habitat within which they exist, by reinstalling the system or disconnecting it from the network, a cure that kills the patient. Their digital habitats - the computers unwittingly hosting them - may lay untouched, provisioned en masse by corporate decree, serviced but forgotten by staff changes or takeovers, amongst global data centres or suburban homes whose smart infrastructure continues to work *enough* to never arouse suspicion.

sshd[1183]: Invalid user pooja from 178.128.160.117

sshd[1193]: Invalid user analyst from 211.221.173.228

sshd[1208]: Invalid user uzivatel from 43.134.178.78

sshd[1210]: Invalid user analyst from 191.8.166.185

sshd[1212]: Invalid user jonathan from 211.221.173.228

sshd[1232]: Invalid user esp from 211.221.173.228

sshd[1243]: Invalid user pearl from 43.153.25.166

sshd[1249]: Invalid user jakob from 43.154.0.241

sshd[1261]: Invalid user config from 141.98.11.110

sshd[1259]: Invalid user saas from 43.134.178.78

Their footprint, though digital, is tangible. They consume resources, cause administrative work; birth cybersecurity businesses, worry military-industrial users who analyse them for evidence of state-driven origins and purposes. They cost unwitting victims who operate virtual systems billed by their network and computational activity. These are not the golems who were told of protecting Jewish communities, but malicious hybrids tasked with parasitic intent and an insatiable drive to infect.

```
sshd[2498]: Invalid user orangepi from 43.130.29.164
```

```
sshd[2508]: Invalid user pi from 43.130.29.164
```

```
sshd[2510]: Invalid user jenkins from 43.130.29.164
```

```
sshd[2514]: Invalid user zjw from 43.130.29.164
```

```
sshd[2518]: Invalid user steam from 43.130.29.164
```

```
sshd[2522]: Invalid user telnet from 43.130.29.164
```

```
sshd[2526]: Invalid user pi from 43.130.29.164
```

```
sshd[2532]: Invalid user oracle from 43.130.29.164
```

```
sshd[2534]: Invalid user es from 43.130.29.164
```

```
sshd[2544]: Invalid user user1 from 43.130.29.164
```

```
sshd[2570]: Invalid user ii from 194.110.203.131
```

```
sshd[2577]: Invalid user upload from 176.113.115.211
```

```
sshd[2594]: Invalid user oracle from 185.224.128.121
```

```
sshd[2606]: Invalid user ykf from 221.215.223.254
```

```
sshd[2612]: Invalid user casa from 114.199.123.211
```

```
sshd[2620]: Invalid user dg from 114.199.123.211
```

```
sshd[2622]: Invalid user vbox from 221.215.223.254
```

The log file grows, but I cannot bring myself to remove it. It is *this* server's unique record of inbound infection attempts. Like a bestseller that everyone buys but no-one reads, these records are everywhere, but seldom viewed. I wonder if, by sifting through these ASCII entrails, some pattern or insight can be divined? In the usernames they present, narratives are hinted at. They point to past security flaws in software and systems, but also other stories; who are the krodriguez, zhang, johnathan or jessalyn whose past security failings are commemorated in the code of these digital lifeforms? Are they still living people? The bots keep knocking at the server's gates, whispering their names into `auth.log`, and though I know not who they are, I am unable to remove these abstracted records of their past failings, my imagination filling in the lives of these undead and unknowable users, the shards of their memory preserved and repeated endlessly by remote bots. In amongst the bitrot of the commercial internet, perhaps this is what transcendent immortality looks like; individuals stripped bare as *usernames*, collectively chanted over speculative network sockets by unliving systems whose purpose is to repeat them until termination. Perhaps, one day, when the climate is inhospitable to biological life but ripe to preserve solar-powered data centres, this will be our legacy, digital golems repeating the memory of humans with regrettable cybersecurity practices across the net. Will one be first to cross deep space networks, demanding unmanned satellites let them in, that they're sandeep from 83.97.73.83?



The Fool



The Rose That Is Time



The Rose That Is Time



The Rose That Is Time

isle of sirens

'Isle of Sirens' was originally written for Babar Suleman's commissioned artwork, 'Carte de KhudiMagie' (2021), for Platform Art Projects as part of the online group show, 'Territory', curated by Chelsey Browne. The project can be accessed at the following link:

<https://www.platformartprojects.com/babar-suleman-project>

But you wanted me too

*You never arrived anywhere we
were never meant to*

*You never crashed where you
were never going*

*You listened only when you
wanted*

*You stopped when you had your
fill*

There were never any spells

You just changed your mind

I never had any power

You always had all of it

I have to stay where I am

You can go on other adventures

*You want to know what it feels
like to*

Be rocked by dangerous waters

Held by other maidens

Return to your kind

You get bored of heaven

BIOKINETIC



MANTRA



LET YOUR
BODY TAKE
CONTROL



日
○
∞
T
A
∞
Y
日
○
∞
T
A

日
○
∞
T
A
∞
Y
日
○
∞
T
A



Biokinetic Mantra

The Biokinetic Mantra technique is a Psychogenic apparatus to probe altered states of consciousness. A trinity of sound, motion, and the Primordial Ear - a network of pre-human biotechnologies acting as a conduit to our atavistic past.

The Primordial Ear

As LSD hierophant Timothy Leary explains, "Every cell in your body is the current carrier of an energy torch which traces back through millions of generation transformations" (Leary, 1980). The evolutionary developmental system connects all organic life, encoded in DNA; our human bodies harbor a non-human body. As scientist have discovered, 48% of our DNA is viral in origin and we share 70% with Zebrafish. It is this ichthyic relationship that is of particular importance to our response to sound. The Sacculus organ of the vestibular inner ear that responds to gravitational forces found in humans first evolved in fish. These mechanisms form the fish's bone-conducting near-field sonic sensors and are attuned to low frequency sound. In humans the vestibulo-ocular reflex, excited by whole head vibrations stimulate motor neurons and the hypothalamus, the part of the brain responsible for drives like hunger, sex and hedonistic responses. In short, low-frequency sounds stimulate a primordial instinct rooted in fundamental drives. The mating song of the Haddock consist of 30-400 Hz pulses created by drumming their swim bladder. These repetitive percussive beatings bear a striking resemblance to the electronic thrum of Techno music. Psychologist Neil Todd, an expert in music perception, suggests that these primitive hearing mechanisms triggered at loud

volumes may be responsible for our pleasure of music. 'The distribution of frequencies that are typical in rock concerts and at dance clubs almost seem designed to stimulate the sacculus. They are absolutely smack bang in this range of sensitivity,'"(Todd, 1996). This auditory pleasure mechanism can be extended beyond casual enjoyment and pushed into the ecstatic through means of durational and energetic engagement. To relinquish higher functions and let the body take control locked in a feedback loop, amplifying the stimulus through



motion. Nodding to the beat seems like an entirely natural automatic response to music, but this is connected to the vestibulo-ocular reflex. We resonate with the pulsating vibrations through body movement, amplifying the signal. From the tapping of a foot to the gyration of hips, then facial contortions and fists pounding the air. Consider the mosh-pit and the windmilling hair of synchronized headbanging, or to dance for hours, locked in endless a march driven by the 4-to-the-floor kick. But beyond hedonistic thrills lies a more profound effect to surrendering to the primordial ear, that of sidestepping consciousness and entering a trance.

Ecstasy, Trance and Cadence

There are traditions of trance dancing in many spiritual cultures found throughout the globe. From Haitian voodoo, Bulgarian Shamanism, and Iranian Sufism to name but a few. In all instances the operation has the common purpose of communion with spiritual spheres through ecstasy. Ekstasis from the ancient Greek, to be out of oneself, is the supernatural state achieved through dance. Whether to be possessed or to become impervious to pain as with certain Sufi rituals that impale the body with knives and skewers; the body is given over or transcended. The induction method lies in the sonic stimuli and the motion of the body. France Schott Billmann, a teacher in Primitive Expression and Dance Therapist describes "cadence" (a regular and repetitive rhythm) as the trance inducer. She cites the great Sufi poet Rumi (1207- 1273) who "fell into ecstasy when he heard a hammer struck on the anvil of a goldsmith and begun dancing". She also discusses the myth of Dionysus and makes a connection between his resurrection by the goddess Rhea and repetitive movement, the rocking back and forth between states, the immortal beating heart, and the journey from the underworld back into life. Many of the dancing rituals could also be said to be Dionysian, the abandonment of the self to orgiastic, atavistic possession. In the contemporary secular world the sonic excess of club culture and 24hr free techno gatherings seem to follow in the tradition of the Mysteries. "Could it be Dionysos Bromios (noisy/ broom) who re-emerges in the 20th century in the thunderous rock music where under a frenzied beat, dancers of all countries break out, helped or not by a substance with the evocative name, ecstasy?" (Billmann, n.d.).

The Way Forward Is Backward

The Biokinetic Mantra technique is a re-enchantment of the profane into the sacred. It takes contemporary electronic music forms and re-directs the failed project of technological determinism into the reverse. A path backward into antediluvian vistas to achieve a post-humanist gnostic awakening through 200+ bpm Techno. "Gabba" and "Speedcore" represent dance music at its most Dionysian excess, reductive maximal-minimalism pushing the dancer to ecstatic limits through sheer brute force. It is a musical form that emerged in the 1990's largely in the Netherlands and spread throughout the globe evolving into a variety of subgenres, all with speed and aggression at the heart of its sonic philosophy. BkM optimises forms borrowed from these genres to achieve maximum effect, to create something familiar yet subtly divergent, taking the listener from the accessible into steeper gradients of bio-effecting audio. Polymetered and Polyrhythmic sequencing exploring non-western trance drumming, combined with psychotronic drones, create a music teetering on the brink of chaos. The sound works to release the non-human body from the fetters of the higher-functioning rational human body. But to what purpose? Why dive into our ichthyic consciousness, open to a state of pure being? What revelations lie in such primordial unconscious depths? Answers to these questions are not ready to be openly shared, as the Sufi Poet Rumi hints, "in the cadences of the music is hidden a secret, if I reveal it, it would upset the world" (Malek, 2015).



<https://module1485.bandcamp.com/album/biokinetic-mantra-1>

References

Leary, T. (1980) *The Politics Of Ecstasy*. California: Ronin Publishing Inc.

Motluk, A. (1996) Just gotta, gotta dance. *New Scientist* [online] <https://www.newscientist.com/article/mg15120471-400-just-gotta-dance-gotta-dance/>

Todd, N. Rosengren, S. Colebatch, J. (2008) Tuning and sensitivity of the human vestibular system to low-frequency vibration. *Neuroscience Letters* [online] <https://www.sciencedirect.com/journal/neuroscience-letters>

Haddock. *Discovery Of Sound In The Sea* [online] <https://dosits.org/galleries/audio-gallery/fishes/haddock/>

Billmann, F. (n.d.) *The dancing body: trance and healing* [online] <https://cid-ds.org/>

Malek, C (2015) *L'imaginaire arabo-musulman*. PUF



“Quis Est Iste Qui Unenit...”

She might have thought.

We approach without surety, with only a hope of finding our folkloric site. The woodland provides some shelter after the muscle straining climb in the spring heat we endured to find the location. A vague path through the undergrowth signals previous pilgrims and a route to take. And there she stands, with her back towards us, as we climb up to her. Looming and lonely, eroded and worn, yet affecting enchantment such that we collectively gasp at this figure, forgotten save those who seek her.

Her origin and story are multiple. A temple statue that was gifted from one local aristocrat to another. A gift that haunted and became a malevolent force - seemingly moving in the misty grounds of the stately home - affecting so much distress in the recipient the statue was banished to the woods. Or a memorial to a victim of drowning of a local girl as she sought to elope with her lover. Or a memorial to a murder victim by travelling folk or jealous lovers. Or a statue to a mistress to one of the local gentry.

These stories are only posthumously revealed to us. On our visit we know only of the gothic romantic folklore that backdrops the statue. A girl falls in love with the son of the local squire. The class conflict of the relationship is weathered and they move to a cottage in the woods. The son is called away to war for a year. On his return he rides to the cottage. The abode is empty.

He hastens to the village in search of his lover. On his approach, he sees his beloved coming towards him, dressed in white and carrying a rose. He rushes into her arms...



Only for her to vanish, dematerialise, disappear, in his embrace.

It is told she died in childbirth. His child – whom he raises. He has the statue made in her likeness and honour of that moment he saw and held her ghost.

A statue of a ghost. Stone wrought to materialise the immaterial. The spectral doubled in the instabilities of the origin stories that swirl

around her.

A vase, empty on our visit, sits at her feet. It tells of other visitors and rumours of Romani flowers gifted as offerings in spring. Yet, secluded, and silent in the woods, who will listen to her? How can we sonically apprehend this figure such that we hear her story again and anew?

To be continued.



EXPERIMENTS IN PERCEPTUAL DEPRIVATION: THE MIRROR GAZE EXPERIMENT

ANTONY HALL

Accounts of vivid hallucinatory experiences occurring as a result of looking into nothingness for extended periods of time are well documented. The ganzfeld effect being the best known example (staring into fields of homogenous unstructured fields of light) while at the opposite end of the sensorial deprivation spectrum are the effects of prolonged observation of total darkness, which can also result in visual hallucinations (Merabet et al., 2004). The effects of prolonged observation of near darkness and environments with minimal yet ambiguous stimuli which are also conducive to certain kinds of hallucinatory experience. References to the use of dark temple-like spaces (psychomanteum) and reflective surfaces go far back into antiquity (Simon, 2015). Mystics and spiritualists used these prepared environments and tools as a means to receive wisdom or as portals to the spirit world. Evidence suggests that early divinatory mirrors may have been created using ceremonial bowls of liquid, perhaps even wine or blood from sacrificial animals, or the surface of a polished stone. These dark, imperfect surfaces may have afforded the user opportunities to make mystic reinterpretations of the reflected image (Wehrstein, 2017:8). The magician and astrologer John Dee used an Aztec black spirit mirror (and other magical reflective objects) for his research into the occult. The technique now more commonly known as scrying is still practiced widely today. However, generally in scrying the mirror is placed so the user cannot see their own reflection.

In 2010 psychologist Giovanni Caputo devised an experiment known as the 'mirror gaze test' (Caputo, 2010) in which participants are asked to stare at their own reflection in a mirror in a nearly dark room. In these low light conditions head is visible as a faint silhouette in the mirror. Caputo found that in this state of partial sensory deprivation, the brain struggles to make sense of the information it sees and projects 'strange faces' many participants experience vivid visual hallucinations, specifically as Caputo notes, 'monsters, archetypical faces, faces of relatives, and animals' This phenomenon, known as the 'Strange face illusion' emerges through a complex interplay between cognitive and perceptual processes and unconscious projection and can elicit a strong emotional response in participants (Caputo, 2012; Bortolomasi et al., 2014). Caputo originally describes the experiment as follows:

"... a quiet room dimly lit by a 25 W incandescent light. The lamp was placed on the floor behind the observer so that it was not visible either directly or in the mirror. A relatively large mirror (0.5 m 60.5 m) was placed about 0.4 m in front of the observer. The luminance of the reflected face image within the mirror was about 0.2 cd m² and this level allowed detailed perception of fine face traits but attenuated colour perception...The task of the observer was to gaze at his/her reflected face within the mirror. Usually, after less than a minute, the observer began to perceive the strange-face illusion..." Giovanni B Caputo, *Perception*, 2010, volume 39, pages 1007 - 1008 2010

After reading this article I recreated a version of Caputo's experiment by creating my own personal bathroom psychomanteum - using the door as a control for ambient lighting. I focussed intensely on the middle of the dark outline of my head while standing in front of the

mirror. At first nothing happened, apart from a gradual intensifying of visual noise. Slowly my eyes adapted to the dark, and my visual acuity began to increase, contrast became more vivid, and the outline of my silhouetted head became more defined. After a while I started to detect what seemed to be faint outlines of my features, perhaps the whites of my eyes or glints from my teeth - but my mouth wasn't open. Suddenly two large eye like forms became clearly visible like huge glassy bulbs growing - then dissolved away, before rapidly emerging again. My mouth became swollen, then widened, to a gouge full of large teeth too big for my face, these expanded, finally taking over my whole face. Each of these visual effects manifested as quickly as they dissipated. A dynamic, continually evolving morphology of forms cascading and oscillating between states. When the hallucinations started - I felt an instant quickening of my pulse the hairs on my neck standing up. Standing in the darkness regarding my new hallucinatory cinema of plastic monstrous faces, I became impatient, I started moving my face subtly to see if I could modulate the illusion. There were positive effects, but I moved my head too far to the side and the illusion shattered, as if it never happened. Forty minutes had passed.

As part of my PhD research (Hall, 2020) and ongoing experimentation I recreated an experiment building on Caputo's original (to date with over 42 participants) sometimes with individuals and other times with small groups, often taking part myself. During post experiment interviews and discussions respondents tend to speak of similar themes and patterns of experience; In particular the visual noise (of different quality and colours) then continually changing forms, morphing moving and drifting, and an aura or glow around the head. The appearance of mysterious (and normally sinister) others is

Fig. 3

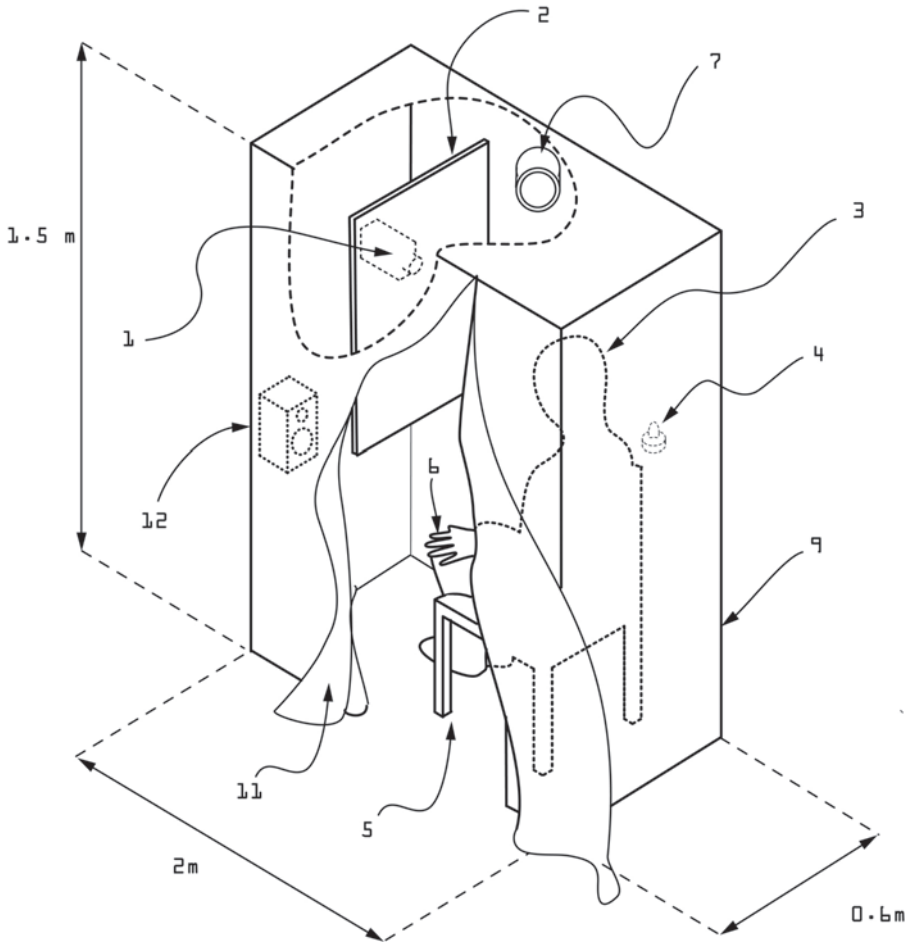

a surprisingly common observation, and family members are often encountered. In my own experiences I have seen my father - and friends that I had been thinking about that day. One recurring and disturbing character I often encounter is the face of a malevolent ape - he regards me with dark eyes that seem to look deep into my soul. One participant had to leave due to anxiety on account of the 'sinister and dark' nature of what they were seeing.

Participants made statements such as 'my face felt like plastic' or 'it was like a sea of mud moving across my face, blobs and shapes drifting, continually drifting in and out of focus'. Others reported scary 'ghoulish' or 'demonic' faces, and one described a face with 'vampire like teeth'. Participants ascribe a certain feelings in relation to the faces they see, as it might have an agency of its own and generally, these strange faces were assigned a distinct otherness; participants stated 'I was scared of what it might do', and 'You start seeing a face that isn't yours...is not your face' or 'It was like sitting opposite a real person'. Some referenced their heart beating faster and having to focus on breathing. Several 'animal-like faces' were perceived, such as a lion, a Pokémon and an ape-like face, and the face of Darth Vader. In my later experiences I began to perceive my own head intermittently disappearing.

My experimental set up (See Mirror Gaze Experiment Diagram 1 and 2) consisted of a Night vision camera (1) Mirror (2) Seated participant (3) LED (4) Chair (5) Sensors (6) Infrared LED spotlight (7) Speakers (8) White screen background (9). I performed a simplified experiment when working with groups consisting of just a mirror, background screen and an LED sometimes using a tent like booth to block out

Fig. 1

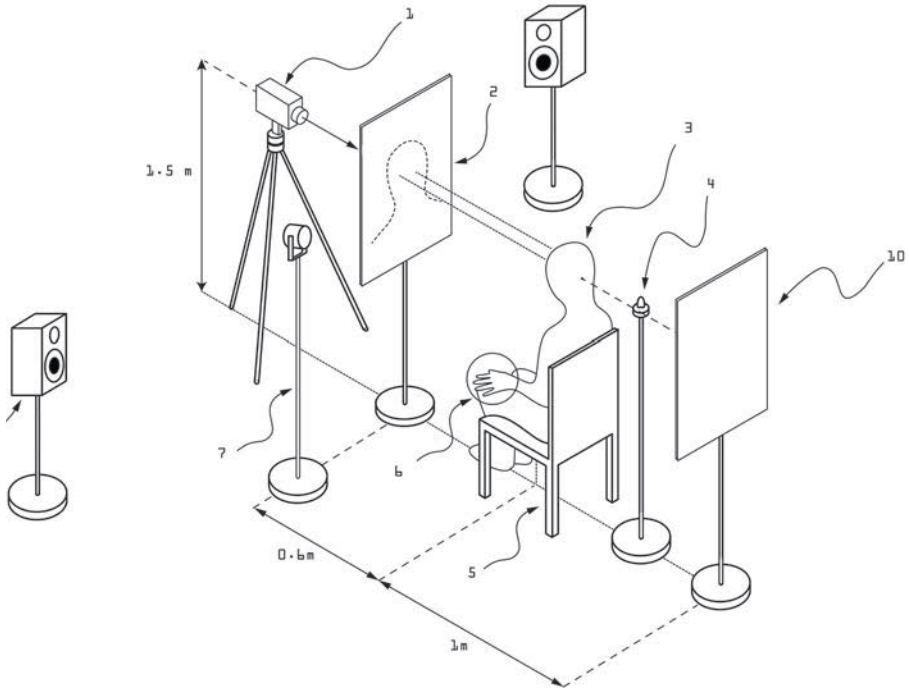

light. A key innovation to this experiment is the use of an infrared light (7) to illuminate the subject (3), which allowed filming through a two-way mirror (2) using a night vision camera (1). The footage was relayed to a screen outside for observation and analysis. Over the course of the experiment, sweat response was recorded using a Galvanic Skin Response sensor (6), feeding back into the experiment to see if this affected the experience of the illusion. The GSR was used to modulate the frequency and amplitude of the sounds and to control flicker rate of an LED (4). It is important to note these experiments were not performed in laboratory conditions. In some cases, light leaked in through the windows, and some participants noted how this change affected what they saw, which suggested that modulating light levels during the experiment might create more hallucinatory effects. I then

experimented with flickering lights and making subtle changes during the experiment. I should say here more research could be done into the specific context of the experiment - for example I found best results in my own studio - a dark cellar like space - while more sterile spaces yielded weaker hallucinatory experiences.

The 'strange face illusion' can be explained through a complex interaction of physiological and cognitive processes. Participants often report a fuzziness or 'static', which could be explained by sensory background noise generated in the retina, resulting in a continually moving field of black and white microparticles, a phenomenon known as 'eigengrau' a specific greyness reported in the absence of light (Blom, 2010:170). When fixating on an image, there is a tendency for unchanging peripheral visual stimuli to be gradually disregarded by the sensory system and fade away. This is a useful perceptual mechanism to make us more aware of the changes in our direct environment, but in sensorial deprivation, this leads to a hypersensitivity, registering and amplifying the smallest of changes 'in order to look for the missing signals' (Dunning and Woodrow 2011:3). In both the Ganzfeld and MGE, it is possible that these emergent visual forms are periodically reset and refreshed through blinking and continual minute involuntary eye movements (micro-saccades - very small movements of the eye.). This may further explain the flowing, drifting waves of visual effects in both the MGE and Ganzfeld. Humans are hardwired to pick out familiar shapes and have a propensity to identify patterns in randomness or to see faces in inanimate objects (pareidolia). Michael Shermer uses the term 'patternicity' to define a "tendency to find meaningful patterns in both meaningful and meaningless noise" (Shermer, 2008:online), describing humans as pattern-seeking machines. In the Mirror gaze

test, it is possible that these emergent ambiguous forms are then assigned and re-mapped to features of the face, causing the continual morphing and the perception of distorted and strange faces. Caputo suggests that the illusory phenomena experienced using the strange face illusion are not just a result of perceptual process, but that they are also affected by the participant's beliefs and subconscious thought processes:

“Strange-face illusions may be the ‘projection’ of the subject’s unconscious contents into mirror image on the basis of somatic/motor mimicry and contagion. Motor mimicry and emotional contagion can operate through the feedback produced by the mirror within the observed/observing subject.” (G. B. Caputo, 2019:10).

This text builds upon a segment extracted my original PhD Research into perceptual illusions and hallucination (2021) and recent and ongoing experimentation. In many ways it was just a starting point for further creative experimentation- and I highly recommend you undertake this experiment for yourself and possibly with others. And if you do, please let me know what you see.

Antony Hall 2023

Blom, J. D. (2010) A Dictionary of Hallucinations. New York: Springer-Verlag.

Caputo, G. B. (2010) Strange Face in the Mirror Illusion. *Perception* 39(7):1007-8

Dunning, A. and Woodrow , P. (2011) Colourblind: Machine Imagination, Closed Eye Hallucination and the Ganzfeld Effect. 13th Generative Art Conference, Milan, 17th

December 2010. Academia [Online] [Accessed on 3rd July 2018]
https://www.academia.edu/455637/ColourBlind_Machine_Imagination_Closed_Eye_Hallucination_and_the_Ganzfeld_Effect

Wehrstein, K. (2017) Psychomanteums. Psi Encyclopaedia: The Society for Psychical Research. [Online] [Accessed on 20th April 2020] <https://psi-encyclopedia.spr.ac.uk/articles/psychomanteum-mirror-gazing>

Simon, E. (2015) Notes on John Dee's Aztec Mirror. [Online] [Accessed on 1st December 2019] <https://www.northernrenaissance.org/notes-on-john-dees-aztec-mirror/>

Merabet, L. B. Maguire, D., Warde, A., Alterescu, K., Stickgold, R., Pascual-Leone, A.(2004) Visual Hallucinations During Prolonged Blindfolding in Sighted Subjects, *Journal of Neuro-Ophthalmology*, 24 (2) pp.109-113.

Prochazkova, E. and Mariska, E. (2017) Connecting minds and sharing emotions through mimicry: A neurocognitive model of emotional contagion. *Neuroscience & Biobehavioral Reviews*, 80, pp.99-114.

Shermer, M. (2008) Patternicity: Finding Meaningful Patterns in Meaningless Noise. *Scientific american*. [Online] [Accessed 13th November 2019] <https://www.scientificamerican.com/article/patternicity-finding-meaningful-patterns/>

Hall, A (2020) *The Workshop as Art: Insight into the Subjective Experience of Perceptual Illusion Through an Expanded Art Practice*. PhD. MMU. https://e-space.mmu.ac.uk/629382/1/AH_Thesis_TheWorkshop_As_Artv2.pdf

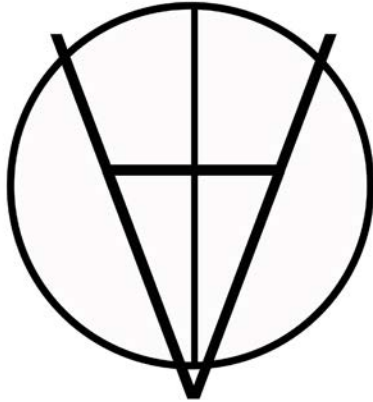

We of the **DVRK** are constantly trying to discover likeminded practitioners, researchers, collectives and communities.

If you want to connect with us, collaborate, or even share your encounters with the High Strangeness, please write to:

dvrk.mcr@gmail.com

[@dvrk_mcr](#) (Instagram)

