



NEC's SINGLE TR. OUTPUT, HIGH COLLECTOR-EMITTER VOLTAGE, 4-PIN ULTRA SMALL FLAT LEAD OPTOCOUPLER

PS2913-1

FEATURES

- **ULTRA SMALL FLAT LEAD PACKAGE:**
4.6 (L) x 2.5 (W) x 2.1 (H) mm
- **ISOLATION DISTANCE:**
0.4 mm MIN
- **HIGH COLLECTOR TO EMITTER VOLTAGE:**
 $V_{CE0} = 120\text{ V}$
- **HIGH ISOLATION VOLTAGE**
 $BV = 2500\text{ Vr.m.s.}$
- **AVAILABLE IN TAPE AND REEL:**
PS2913-1-F3, F4: 3500 pcs/reel

DESCRIPTION

NEC's PS2913-1 is an optically coupled isolator containing a GaAs light emitting diode and an NPN silicon phototransistor is one package for high density mounting applications. This device is housed in an ultra small flat-lead package which realizes a reduction in mounting area of about 30% compared with the PS28XX series.

APPLICATIONS

- HYBRID IC
- POWER SUPPLY

ELECTRICAL CHARACTERISTICS (TA=25°C)

PART NUMBER			PS2913-1			
	SYMBOLS	PARAMETERS	UNITS	MIN	TYP	MAX
Diode	V _F	Forward Voltage, I _F = 1 mA	V	0.9	1.1	1.3
	I _R	Reverse Current, V _R = 5 V	μA			5
	C _T	Terminal Capacitance, V = 0, f = 1.0 MHz	pF		15	
Transistor	I _{CEO}	Collector to Emitter Dark Current, I _F = 1 mA, V _{CE} = 120 V	nA			100
Coupled	CTR	Current Transfer Ratio (I _c /I _F), I _F = 1 mA, V _{CE} = 5 V	%	50	100	200
	V _{CE(sat)}	Collector Saturation Voltage, I _F = 1 mA, I _c = 0.2 mA	V		0.13	0.3
	R _{I-O}	Isolation Resistance, V _{I-O} = 1.0 kVDC	Ω	10 ¹¹		
	C _{I-O}	Isolation Capacitance, V = 0 V, f = 1.0 MHz	pF		0.4	
	t _r	Rise Time ¹	V _{CC} = 5 V, I _c = 2 mA, R _L = 100 Ω	μs	10	
	t _f	Fall Time ¹		μs	10	
	t _{ON}	On Time ¹	V _{CC} = 5 V, I _F = 1 mA, R _L = 5 kΩ	μs	80	
	t _S	Storage Time ¹		μs	5	
t _{OFF}	Off Time ¹	μs		50		

Note:

1. Test Circuit for Switching Time

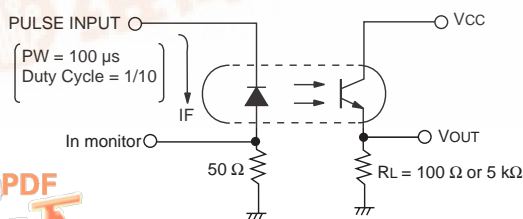

ABSOLUTE MAXIMUM RATINGS¹ (T_A = 25°C)

SYMBOLS	PARAMETERS	UNITS	RATINGS
Diode			
I _F	Forward Current (DC)	mA	50
ΔI _F /°C	Forward Current Derating	mA/°C	0.5
I _F (Peak)	Peak Forward Current ²	A	0.5
P _D	Power Dissipation	mW	60
V _R	Reverse Voltage	V	6
Transistor			
V _{CEO}	Collector to Emitter Voltage	V	120
V _{ECO}	Emitter to Collector Voltage	V	6
I _C	Collector Current	mA	30
ΔP _C /°C	Power Dissipation Derating	mW/°C	1.2
P _C	Power Dissipation	mW	120
Coupled			
V _{ISO}	Isolation Voltage ³	V _{r.m.s.}	2500
P _T	Total Power Dissipation	mW	160
T _A	Operating Ambient Temp.	°C	-55 to +100
T _{STG}	Storage Temperature	°C	-55 to +150

Notes:

1. Operation in excess of any one of these parameters may result in permanent damage.
2. PW = 100 μs, Duty Cycle = 1%.
3. AC voltage for 1 minute at T_A = 25°C, RH = 60% between input and output.

ORDERING INFORMATION

PART NUMBER	PACKING STYLE
PS2913-1-F3	Embossed Tape 3500 pcs/reel
PS2913-1-F4	

RECOMMENDED MOUNT PAD DIMENSIONS (Units in mm)

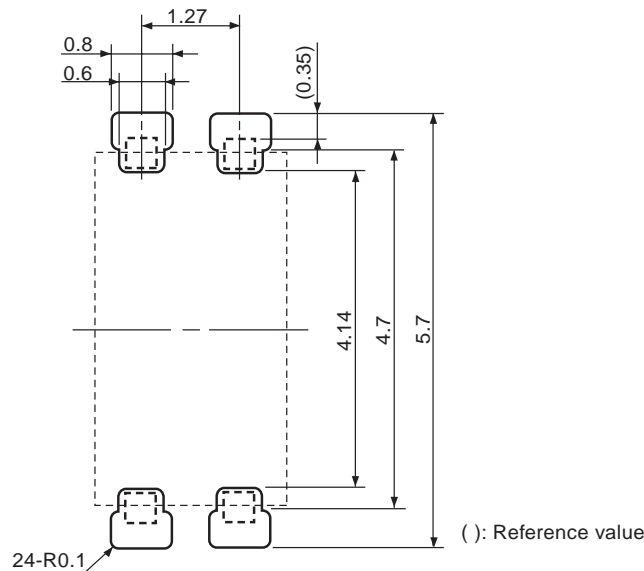

Remark:

This drawing is considered to meet air and outer creepage distance 4.0 minimum. All dimensions in this figure must be evaluated before use.

OPTOCOUPLER CONSTRUCTION

PARAMETER	UNITS (MIN)
Air Distance	4 mm
Creepage Distance	4 mm
Isolation Distance	0.4 mm

CAUTIONS REGARDING NOISE:

Be aware that when voltage is applied suddenly between the optocoupler's input and output or between collector-emitters at startup, the output side may enter the on state, even if the voltage is within the absolute maximum ratings.

OUTLINE DIMENSIONS (Units in mm)

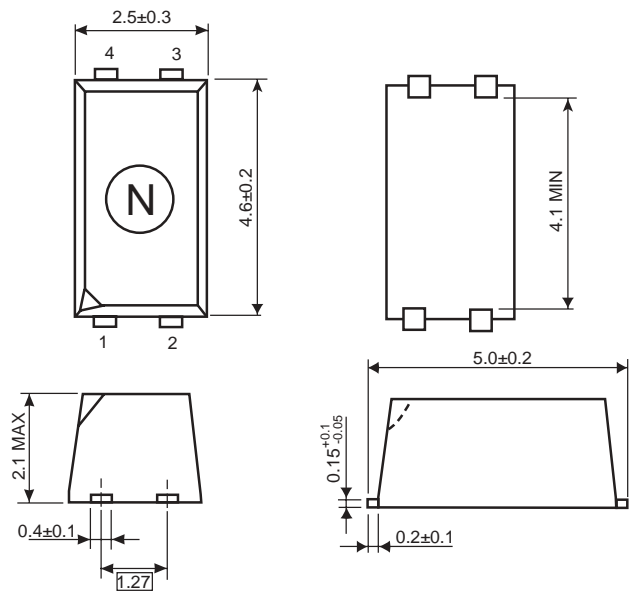

TOP VIEW

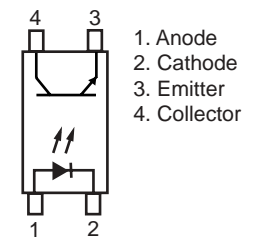

MARKING

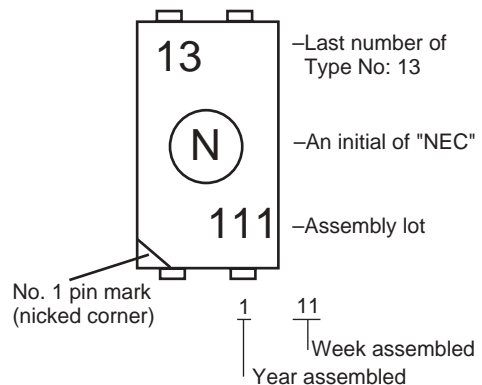

TYPICAL CHARACTERISTICS ($T_A = 25^\circ\text{C}$, unless otherwise specified)

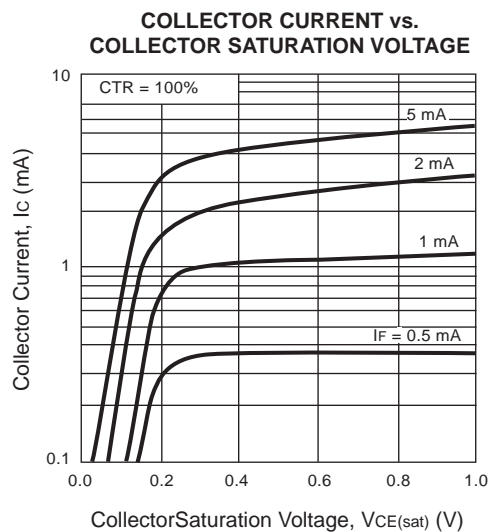
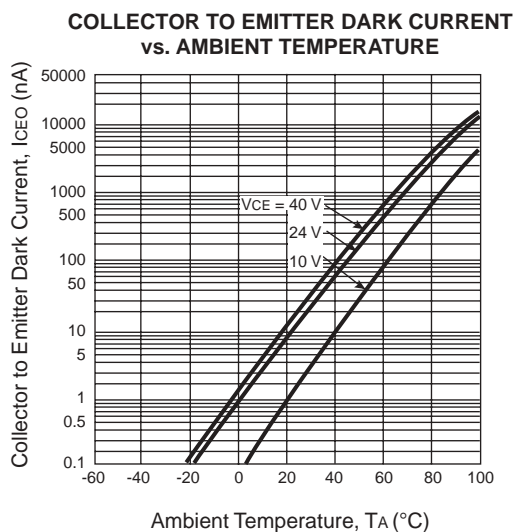
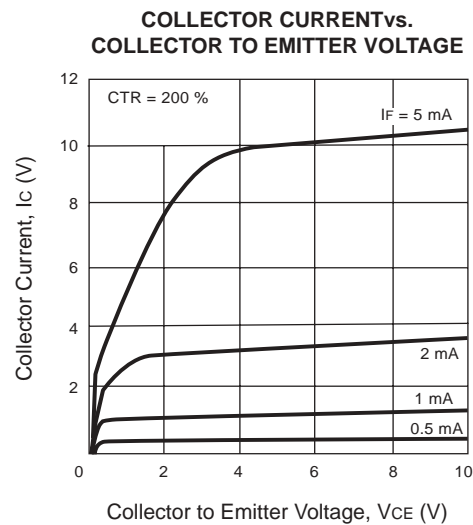
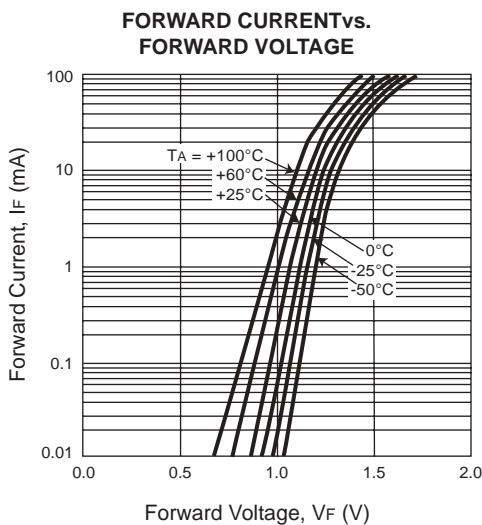
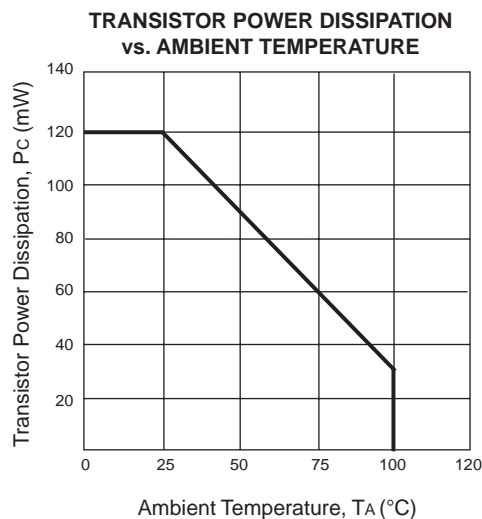
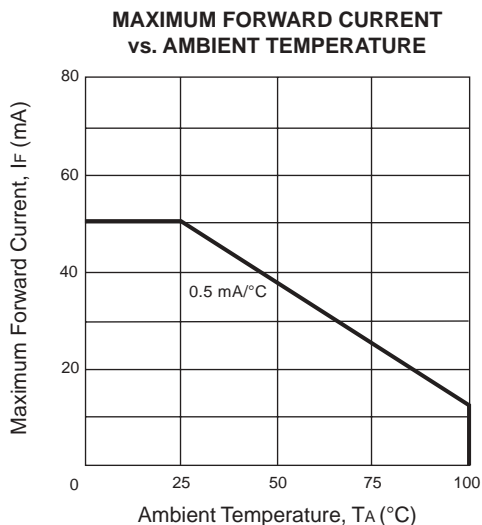

TYPICAL CHARACTERISTICS ($T_A = 25^\circ\text{C}$, unless otherwise specified)

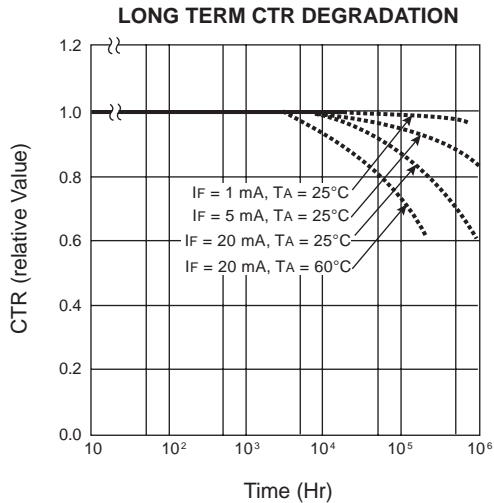
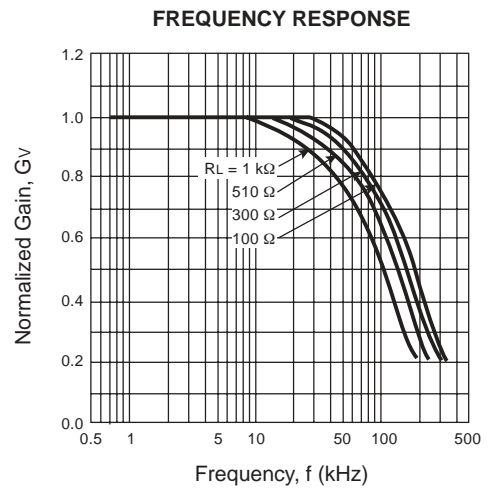
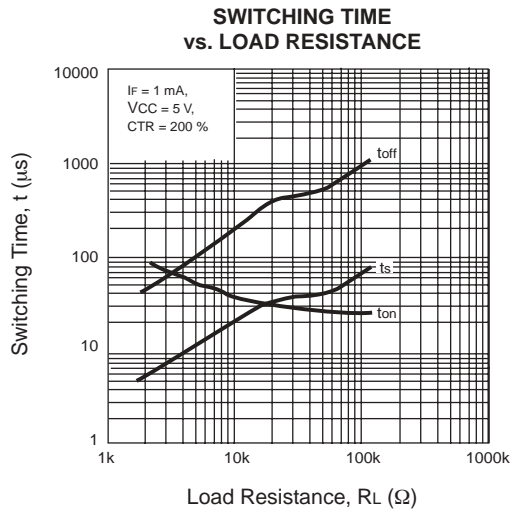
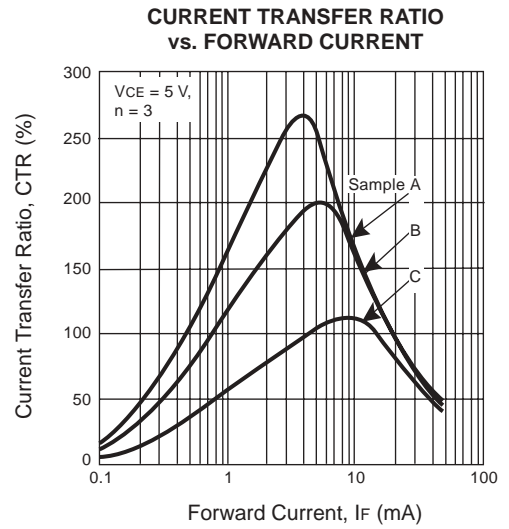
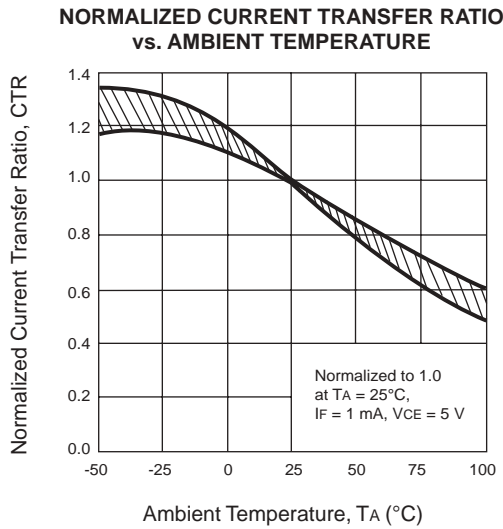

REMARK: The graphs indicate nominal characteristics.

TAPING SPECIFICATIONS (Units in mm)

TAPE OUTLINE AND DIMENSIONS

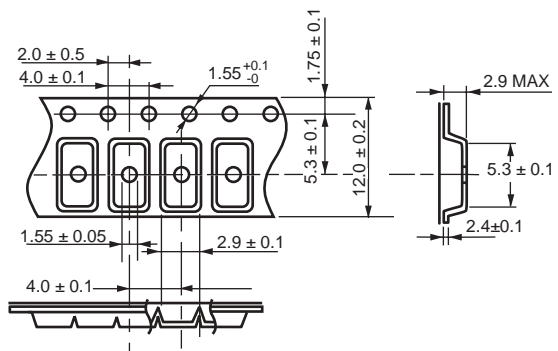

TAPE DIRECTION

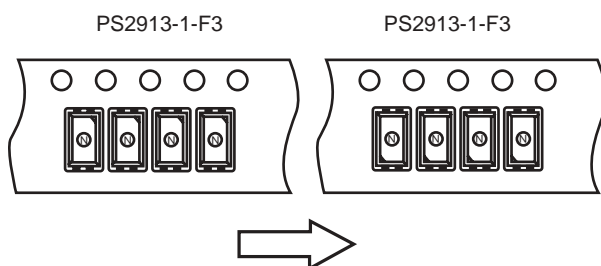

REEL OUTLINE AND DIMENSIONS

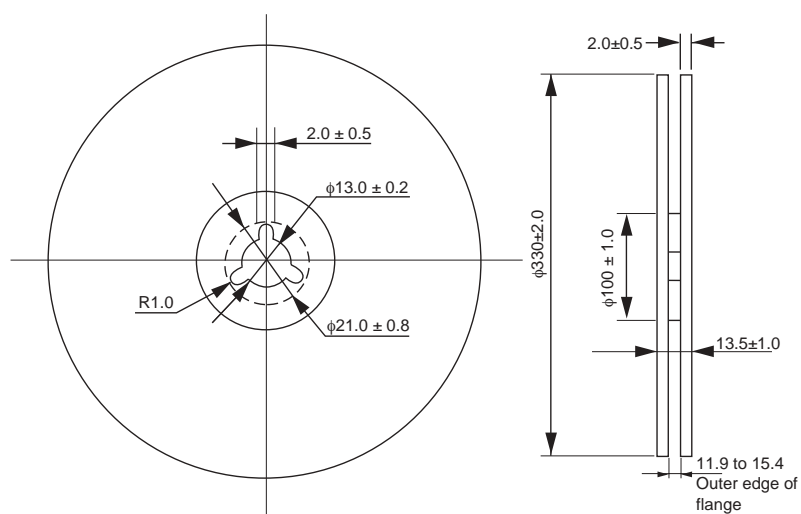

Packing: 3500 pcs/reel

RECOMMENDED SOLDERING CONDITIONS

(1) Infrared reflow soldering

- Peak reflow temperature 260 °C or below (package surface temperature)
- Time of peak reflow temperature 10 seconds or less
- Time of temperature higher than 220 °C 60 seconds or less
- Time to preheat temperature from 120 to 180°C 120±30 s
- Number of reflows Three
- Flux Rosin flux containing small amount of chlorine (The flux with a maximum chlorine content of 0.2 Wt % is recommended).

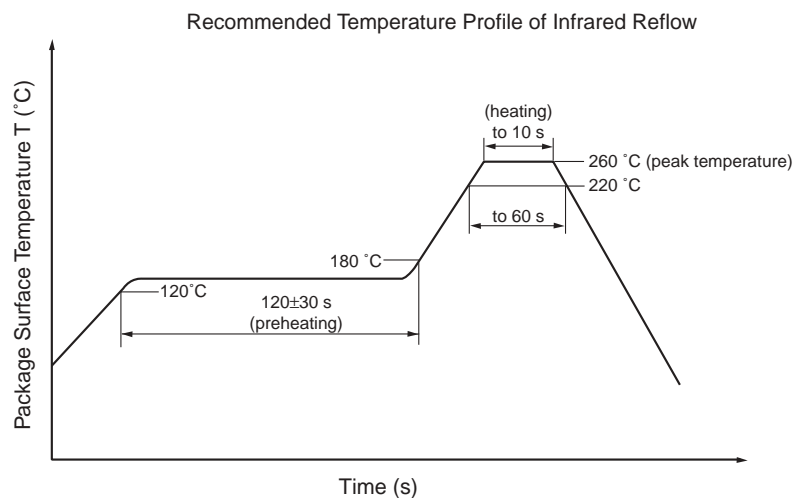

(2) Wave soldering

- Temperature 260 °C or below (molten solder temperature)
- Time 10 seconds or less
- Preheating conditions 120°C or below (package surface temperature)
- Number of times One (Allowed to be dipped in solder including plastic mold portion.)
- Flux Rosin flux containing small amount of chlorine (The flux with a maximum chlorine content of 0.2 Wt % is recommended).

(3) Cautions

- Fluxes Avoid removing the residual flux with chlorine-based cleaning solvent after a reflow process.

USAGE CAUTIONS

1. Protect against static electricity when handling.
2. Avoid storage at a high temperature and high humidity.

Life Support Applications

These NEC products are not intended for use in life support devices, appliances, or systems where the malfunction of these products can reasonably be expected to result in personal injury. The customers of CEL using or selling these products for use in such applications do so at their own risk and agree to fully indemnify CEL for all damages resulting from such improper use or sale.