

**SONY**

**1T378A**

**Variable Capacitance Diode**

**Description**

The 1T378A is a variable capacitance diode designed for electronic tuning of wide-band CATV tuners, and the super miniature package allows the tuner miniaturization.

High capacitance ratio ( $C_{25}/C_{28}$ ) is improved to support guard band.

**Features**

- Super miniature package
- Low series resistance 0.85  $\Omega$  Max. ( $f=470$  MHz)
- Large capacitance ratio 12.5 Typ. ( $C_2/C_{25}$ )  
1.03 Min. ( $C_{25}/C_{28}$ )
- Small leakage current 10 nA Max. ( $V_R=28$  V)
- Capacitance deviation within 2 %

**Applications**

Electronic tuning of VHF band and wide-band CATV tuners

**Structure**

Silicon epitaxial planar type diode

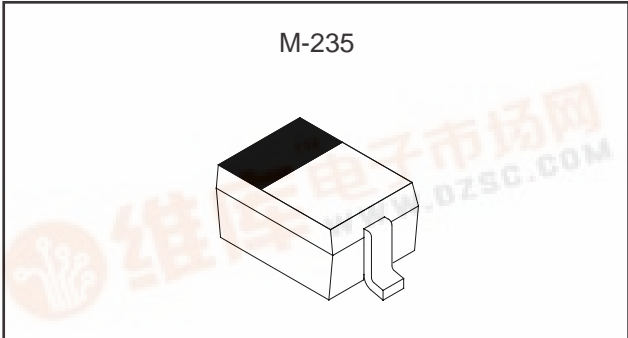

**Absolute Maximum Ratings** ( $T_a=25$  °C)

- Reverse voltage  $V_R$  34 V
- Operating temperature  $T_{opr}$  -20 to +75 °C
- Storage temperature  $T_{stg}$  -65 to +150 °C

**Electrical Characteristics**

( $T_a=25$  °C)

Item	Symbol	Conditions	Min.	Typ.	Max.	Unit
Reverse current	$I_R$	$V_R=28$ V			10	nA
Reverse voltage	$V_R$	$I_R=1$ $\mu$ A	34			V
Diode capacitance	$C_2$	$V_R=2$ V, $f=1$ MHz	33.0		39.0	pF
	$C_{25}$	$V_R=25$ V, $f=1$ MHz	2.57		3.00	pF
Capacitance ratio	$C_2/C_{25}$		12.0	12.5		
	$C_{25}/C_{28}$		1.03			
Series resistance	$r_s$	$C_D=14$ pF, $f=470$ MHz			0.85	$\Omega$
Capacitance deviation in a matching group	$\Delta C$	$V_R=2$ to 25 V, $f=1$ MHz			2	%

The continuous 20 pieces of  $\Delta C$  are guaranteed.

Sony reserves the right to change products and specifications without prior notice. This information does not convey any license by any implication or otherwise under any patents or other right. Application circuits shown, if any, are typical examples illustrating the operation of the devices. Sony cannot assume responsibility for any problems arising out of the use of these circuits.



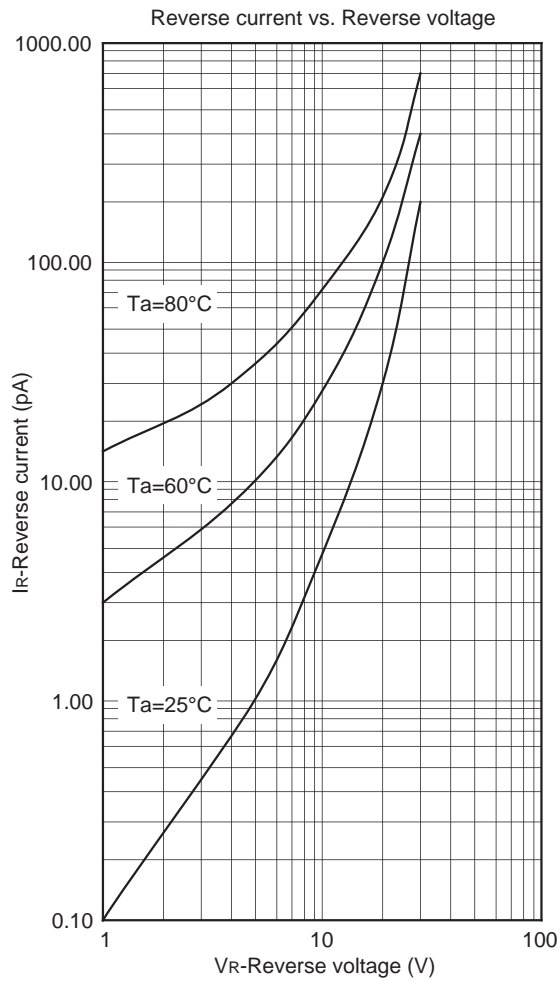
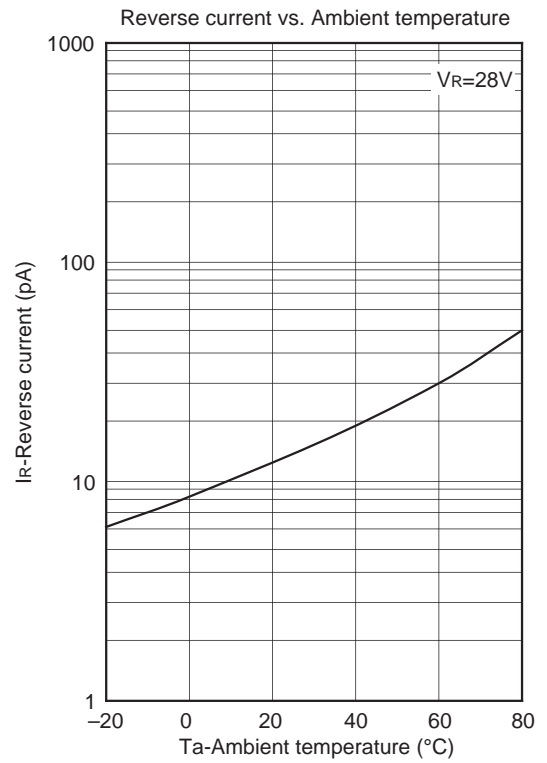
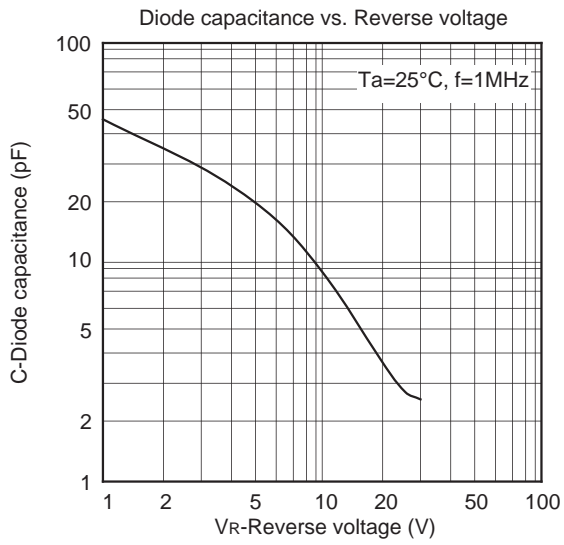

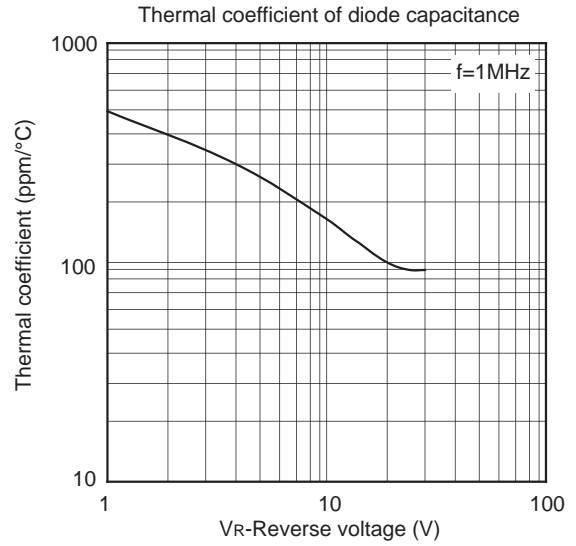
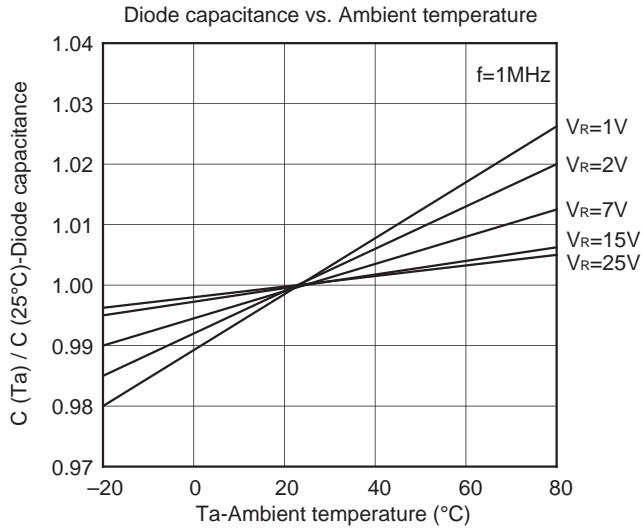
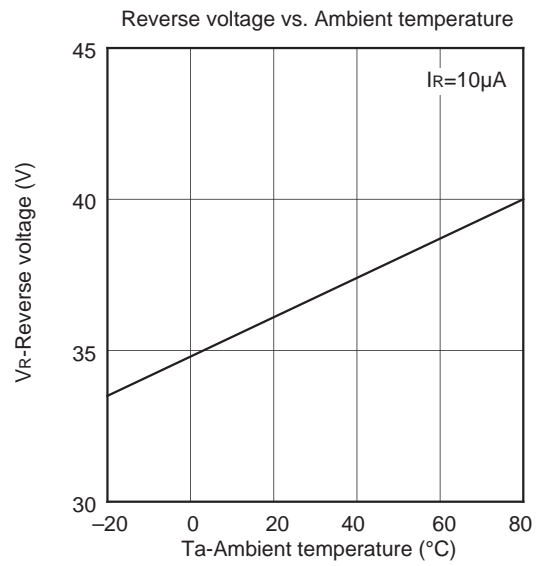
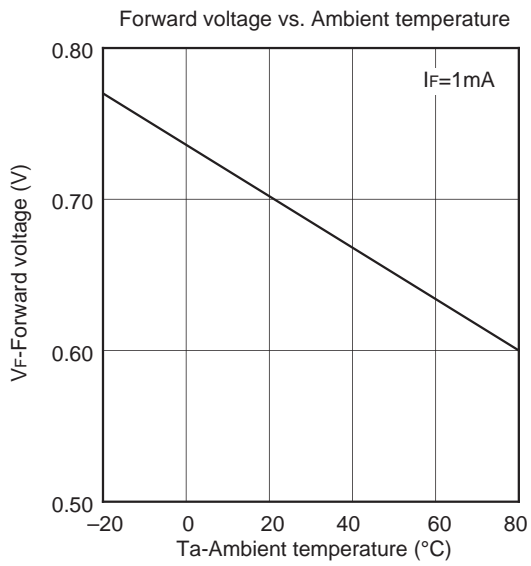

Package Outline Unit : mm

M-235

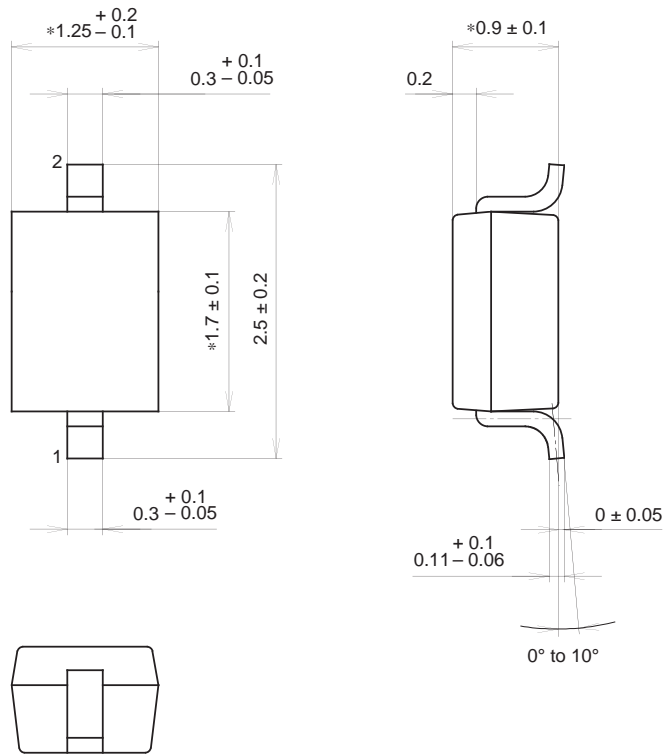

NOTE: Dimension "\*" does not include mold protrusion.

SONY CODE	M-235
EIAJ CODE	—
JEDEC CODE	—

PACKAGE WEIGHT	0.1g
----------------	------

Marking

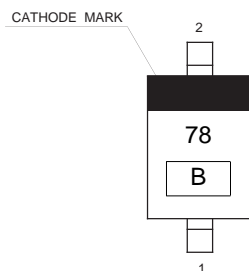

Notes

- 1) B: Lot No. (Year and Month of manufacture)  
 Year; Last one digit  
 Month; A, B, C (for Oct. to Dec.)  
 1 to 9 (for Jan. to Sept.)