



Low Noise/Low Power

X9408

Quad 2-Wire EEPOT™ Nonvolatile Digital Potentiometer

FEATURES

- Four EEPOTs in One Package
- Two-Wire Serial Interface
- Hardware Write Protection, \overline{WP}
- Register Oriented Format
 - Direct Read/Write Wiper Position
 - Store as Many as Four Positions per Pot
- Power Supplies
 - $V_{CC} = 2.7V$ to $5.5V$
 - $V_+ = 2.7V$ to $5.5V$
 - $V_- = -2.7V$ to $-5.5V$
- Low Power CMOS
 - Standby Current $< 1\mu A$
 - Ideal for Battery Operated Applications
- High Reliability
 - Endurance - 100,000 Data Changes per Register
 - Register Data Retention - 100 years
- 16 Bytes of E²PROM memory
- 10K Ohm Resistor Array
- Resolution: 64 Taps each Pot
- 24-Pin Plastic DIP, 24-Lead TSSOP and 24-Lead SOIC Packages

DESCRIPTION

The X9408 integrates four nonvolatile EEPOTs, digitally controlled potentiometers, on a monolithic CMOS micro-circuit.

The X9408 contains four resistor arrays, each composed of 63 resistive elements. Between each element and at either end are tap points accessible to the wiper elements. The position of the wiper element on the array is controlled by the user through the two wire serial bus interface.

Each resistor array has associated with it a Wiper Counter Register and four 6 bit data registers that can be directly written and read by the user. The contents of the Wiper Counter Register set the position of the wiper on the resistor array. Power-up recalls the contents of data register R0 to the Wiper Counter Register.

FUNCTIONAL DIAGRAM

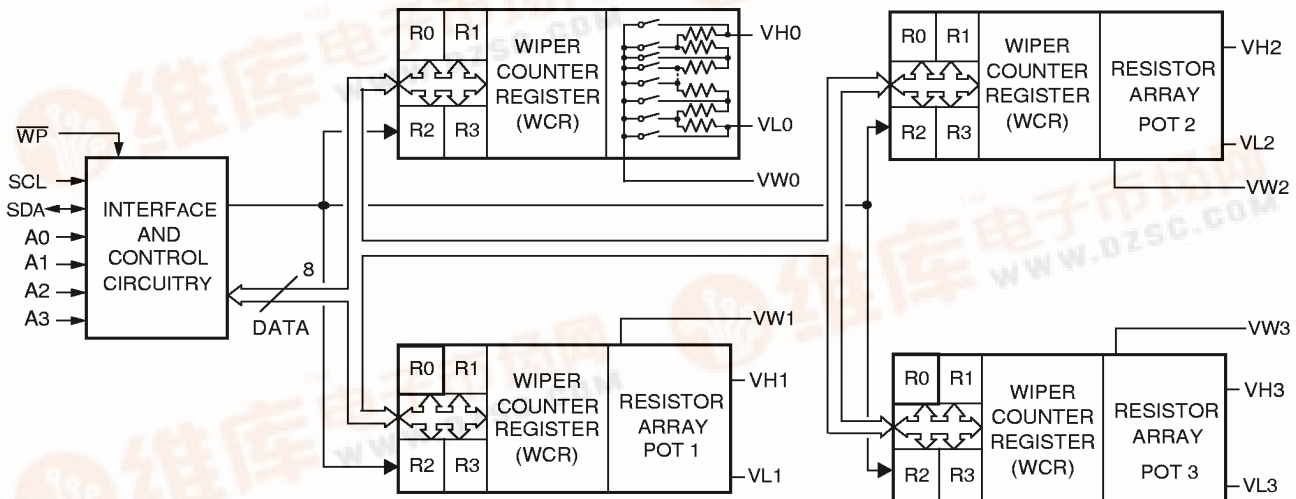

X9408

PIN DESCRIPTIONS

Host Interface Pins

Serial Clock (SCL)

The SCL input is used to clock data into and out of the X9408.

Serial Data (SDA)

SDA is a bidirectional pin used to transfer data into and out of the device. It is an open drain output and may be wire-ORed with any number of open drain or open collector outputs. An open drain output requires the use of a pull-up resistor. For selecting typical values, refer to the guidelines for calculating typical values on the bus pull-up resistors graph.

Device Address (A₀–A₃)

The Address inputs are used to set the least significant 4 bits of the 8-bit slave address. A match in the slave address serial data stream must be made with the Address input in order to initiate communication with the X9408. A maximum of 16 devices may occupy the 2-wire serial bus.

Potentiometer Pins

V_H ($V_{H0} - V_{H3}$), V_L ($V_{L0} - V_{L3}$)

The VH and VL inputs are equivalent to the terminal connections on either end of a mechanical potentiometer.

V_W ($V_{W0} - V_{W3}$)

The wiper outputs are equivalent to the wiper output of a mechanical potentiometer.

Hardware Write Protect Input (\overline{WP})

The \overline{WP} pin when low prevents nonvolatile writes to the wiper counter registers.

Analog Supplies V+, V-

The Analog Supplies V+, V- are the supply voltages for the EEPOT analog section.

PIN NAMES

Symbol	Description
SCL	Serial Clock
SDA	Serial Data
A0-A3	Device Address
V_{H0} – V_{H3} , V_{L0} – V_{L3}	Potentiometers (terminal equivalent)
V_{W0} – V_{W3}	Potentiometers (wiper equivalent)

PIN CONFIGURATION

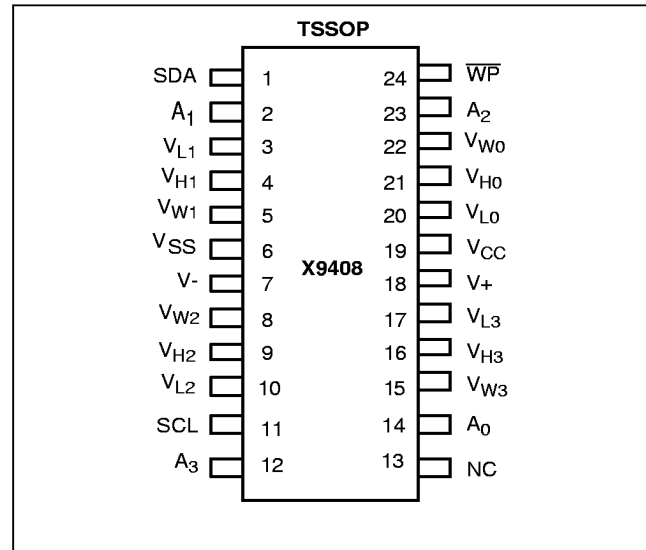
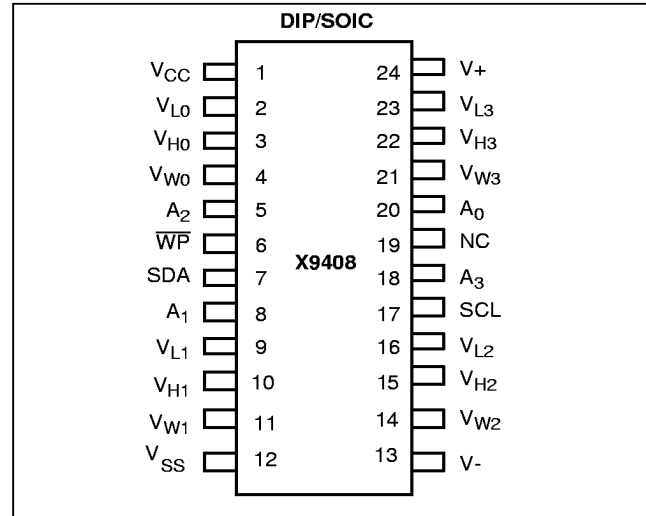

\overline{WP}	Hardware Write Protection
V+,V-	Analog Supplies
VCC	System Supply Voltage
VSS	System Ground
NC	No Connection

X9408

PRINCIPLES OF OPERATION

The X9408 is a highly integrated microcircuit incorporating four resistor arrays and their associated registers and counters and the serial interface logic providing direct communication between the host and the EEPOT potentiometers.

Serial Interface

The X9408 supports a bidirectional bus oriented protocol. The protocol defines any device that sends data onto the bus as a transmitter and the receiving device as the receiver. The device controlling the transfer is a master and the device being controlled is the slave. The master will always initiate data transfers and provide the clock for both transmit and receive operations. Therefore, the X9408 will be considered a slave device in all applications.

Clock and Data Conventions

Data states on the SDA line can change only during SCL LOW periods (t_{LOW}). SDA state changes during SCL HIGH are reserved for indicating start and stop conditions.

Start Condition

All commands to the X9408 are preceded by the start condition, which is a HIGH to LOW transition of SDA while SCL is HIGH (t_{HIGH}). The X9408 continuously monitors the SDA and SCL lines for the start condition and will not respond to any command until this condition is met.

Stop Condition

All communications must be terminated by a stop condition, which is a LOW to HIGH transition of SDA while SCL is HIGH.

Acknowledge

Acknowledge is a software convention used to provide a positive handshake between the master and slave devices on the bus to indicate the successful receipt of data. The transmitting device, either the master or the slave, will release the SDA bus after transmitting eight bits. The master generates a ninth clock cycle and during this period the receiver pulls the SDA line LOW to acknowledge that it successfully received the eight bits of data.

The X9408 will respond with an acknowledge after recognition of a start condition and its slave address and once again after successful receipt of the command byte. If the command is followed by a data byte the X9408 will respond with a final acknowledge.

Array Description

The X9408 is comprised of four resistor arrays. Each array contains 63 discrete resistive segments that are connected in series. The physical ends of each array are equivalent to the fixed terminals of a mechanical potentiometer (V_H and V_L inputs).

At both ends of each array and between each resistor segment is a CMOS switch connected to the wiper (V_W) output. Within each individual array only one switch may be turned on at a time. These switches are controlled by the Wiper Counter Register (WCR). The six bits of the WCR are decoded to select, and enable, one of sixty-four switches.

The WCR may be written directly, or it can be changed by transferring the contents of one of four associated data registers into the WCR. These data registers and the WCR can be read and written by the host system.

Device Addressing

Following a start condition the master must output the address of the slave it is accessing. The most significant four bits of the slave address are the device type identifier (refer to Figure 1 below). For the X9408 this is fixed as 0101[B].

Figure 1. Slave Address

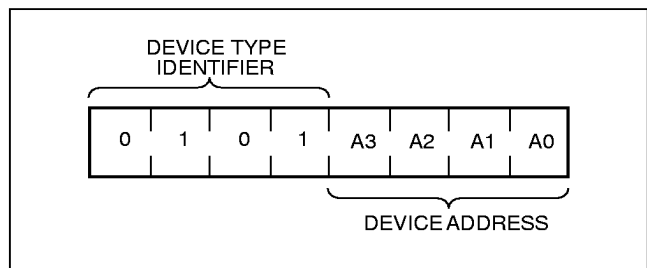

The next four bits of the slave address are the device address. The physical device address is defined by the state of the A0-A3 inputs. The X9408 compares the serial data stream with the address input state; a successful compare of all four address bits is required for the X9408 to respond with an acknowledge. The A₀-A₃ inputs can be actively driven by CMOS input signals or tied to V_{CC} or V_{SS} .

X9408

Acknowledge Polling

The disabling of the inputs, during the internal non-volatile write operation, can be used to take advantage of the typical 5ms E²PROM write cycle time. Once the stop condition is issued to indicate the end of the nonvolatile write command the X9408 initiates the internal write cycle. ACK polling can be initiated immediately. This involves issuing the start condition followed by the device slave address. If the X9408 is still busy with the write operation no ACK will be returned. If the X9408 has completed the write operation an ACK will be returned and the master can then proceed with the next operation.

Flow 1. ACK Polling Sequence

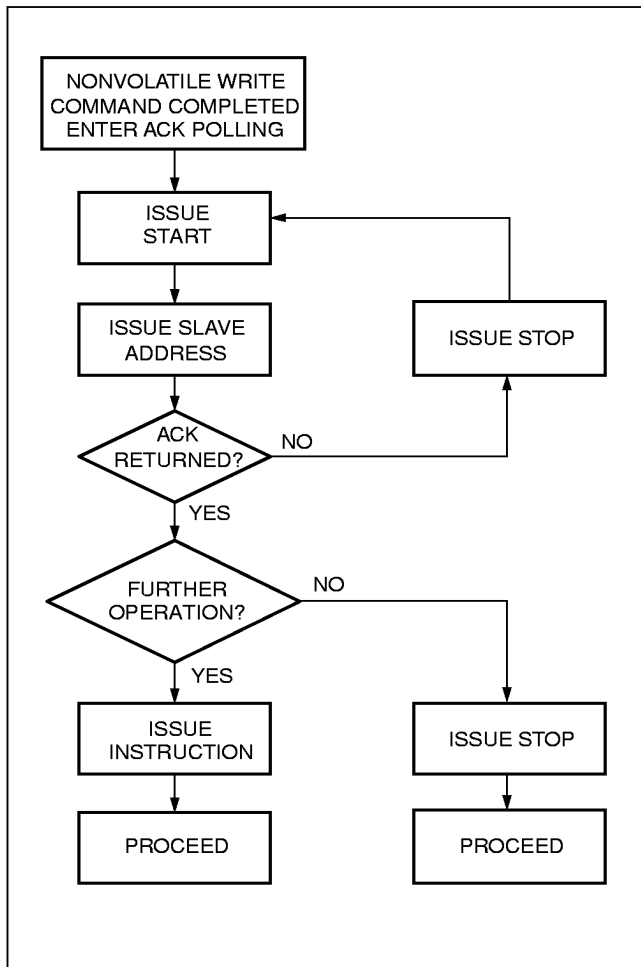

Instruction Structure

The next byte sent to the X9408 contains the instruction and register pointer information. The four most significant bits are the instruction. The next four bits point to one of

the two pots and when applicable they point to one of four associated registers. The format is shown below in Figure 2.

Figure 2. Instruction Byte Format

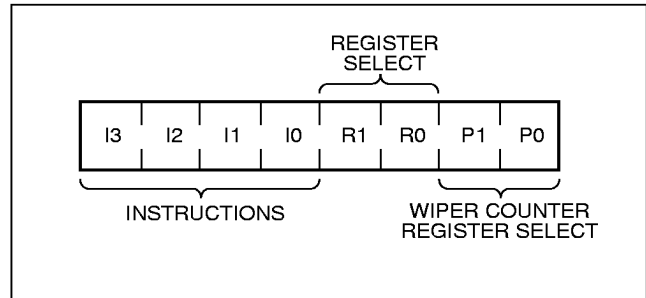

The four high order bits define the instruction. The next two bits (R1 and R0) select one of the four registers that is to be acted upon when a register oriented instruction is issued. The last bits (P1, P0) select which one of the four potentiometers is to be affected by the instruction.

Four of the nine instructions end with the transmission of the instruction byte. The basic sequence is illustrated in Figure 3. These two-byte instructions exchange data between the Wiper Counter Register and one of the data registers. A transfer from a data register to a Wiper Counter Register is essentially a write to a static RAM. The response of the wiper to this action will be delayed t_{WRL} . A transfer from the Wiper Counter Register (current wiper position), to a data register is a write to nonvolatile memory and takes a minimum of t_{WR} to complete. The transfer can occur between one of the four potentiometers and one of its associated registers; or it may occur globally, wherein the transfer occurs between all of the potentiometers and one of their associated registers.

Four instructions require a three-byte sequence to complete. These instructions transfer data between the host and the X9408; either between the host and one of the data registers or directly between the host and the Wiper Control Latch. These instructions are: Read Wiper Control Latch (read the current wiper position of the selected pot), Write Wiper Counter Register (change current wiper position of the selected pot), Read Data Register (read the contents of the selected nonvolatile register) and Write Data Register (write a new value to the selected data register). The sequence of operations is shown in Figure 4.

X9408

Figure 3. Two-Byte Command Sequence

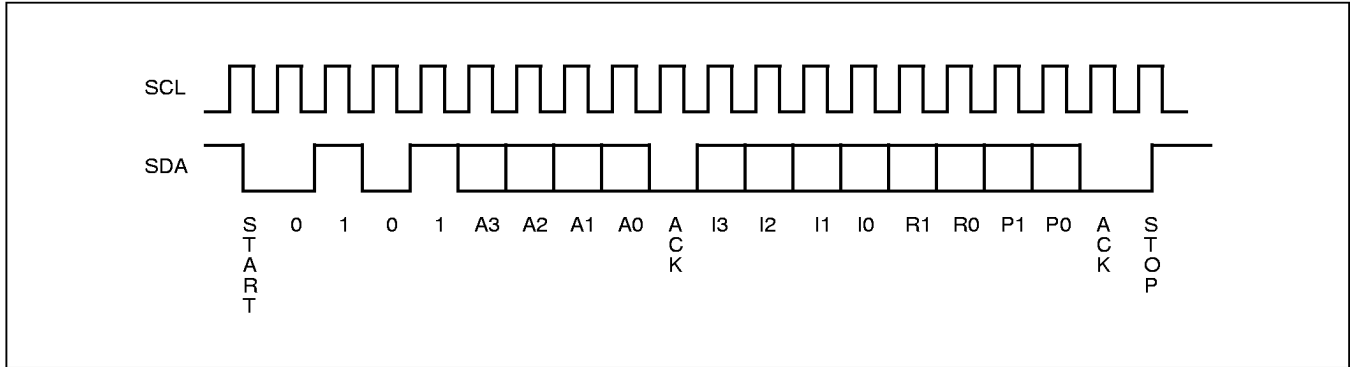

The Increment/Decrement command is different from the other commands. Once the command is issued and the X9408 has responded with an acknowledge, the master can clock the selected wiper up and/or down in one segment steps; thereby, providing a fine tuning capability to the host. For each SCL clock pulse (t_{HIGH}) while SDA

is HIGH, the selected wiper will move one resistor segment towards the V_H terminal. Similarly, for each SCL clock pulse while SDA is LOW, the selected wiper will move one resistor segment towards the V_L terminal. A detailed illustration of the sequence and timing for this operation are shown in Figures 5 and 6 respectively.

Table 1. Instruction Set

Instruction	Instruction Set								Operation
	I ₃	I ₂	I ₁	I ₀	R ₁	R ₀	P ₁	P ₀	
Read Wiper Counter Register	1	0	0	1	0	0	1/0	1/0	Read the contents of the Wiper Counter Register pointed to by P ₁ –P ₀
Write Wiper Counter Register	1	0	1	0	0	0	1/0	1/0	Write new value to the Wiper Counter Register pointed to by P ₁ –P ₀
Read Data Register	1	0	1	1	1/0	1/0	1/0	1/0	Read the contents of the Data Register pointed to by P ₁ –P ₀ and R ₁ –R ₀
Write Data Register	1	1	0	0	1/0	1/0	1/0	1/0	Write new value to the Data Register pointed to by P ₁ –P ₀ and R ₁ –R ₀
XFR Data Register to Wiper Counter Register	1	1	0	1	1/0	1/0	1/0	1/0	Transfer the contents of the Data Register pointed to by P ₁ –P ₀ and R ₁ –R ₀ to its associated Wiper Counter Register
XFR Wiper Counter Register to Data Register	1	1	1	0	1/0	1/0	0	1/0	Transfer the contents of the Wiper Counter Register pointed to by P ₁ –P ₀ to the Data Register pointed to by R ₁ –R ₀
Global XFR Data Registers to Wiper Counter Registers	0	0	0	1	1/0	1/0	0	0	Transfer the contents of both Data Registers pointed to by R ₁ –R ₀ to their respective Wiper Counter Registers
Global XFR Wiper Counter Registers to Data Register	1	0	0	0	1/0	1/0	0	0	Transfer the contents of both Wiper Counter Registeres to their respective data Registers pointed to by R ₁ –R ₀
Increment/Decrement Wiper Counter Register	0	0	1	0	0	0	1/0	1/0	Enable Increment/decrement of the Control Latch pointed to by P ₁ –P ₀

Notes: (7) 1/0 = data is one or zero

X9408

Figure 4. Three-Byte Command Sequence

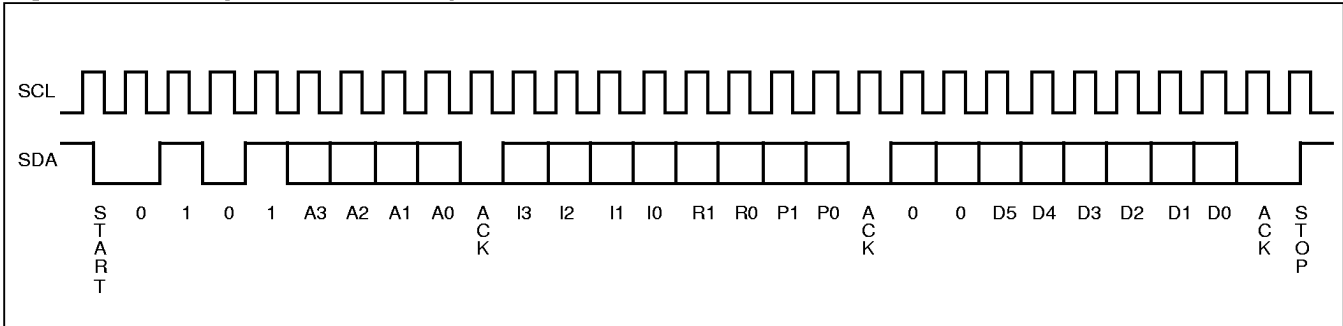

Figure 5. Increment/Decrement Command Sequence

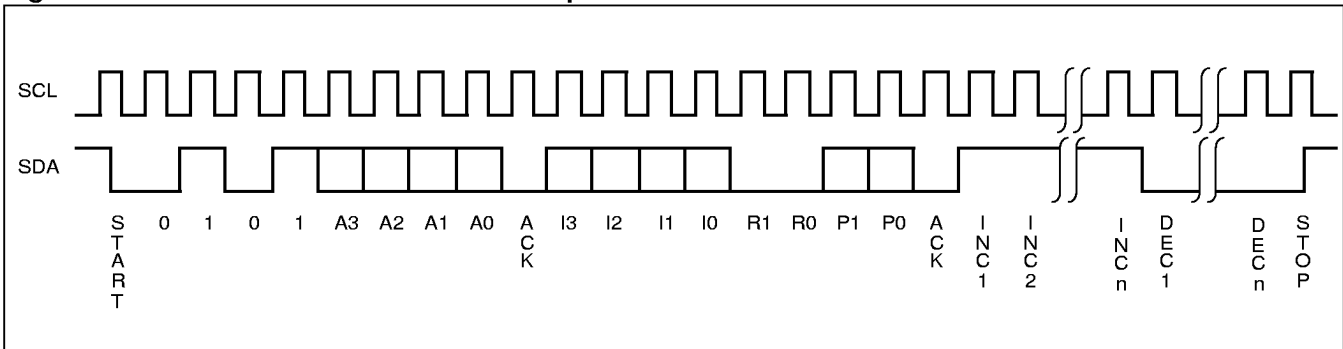
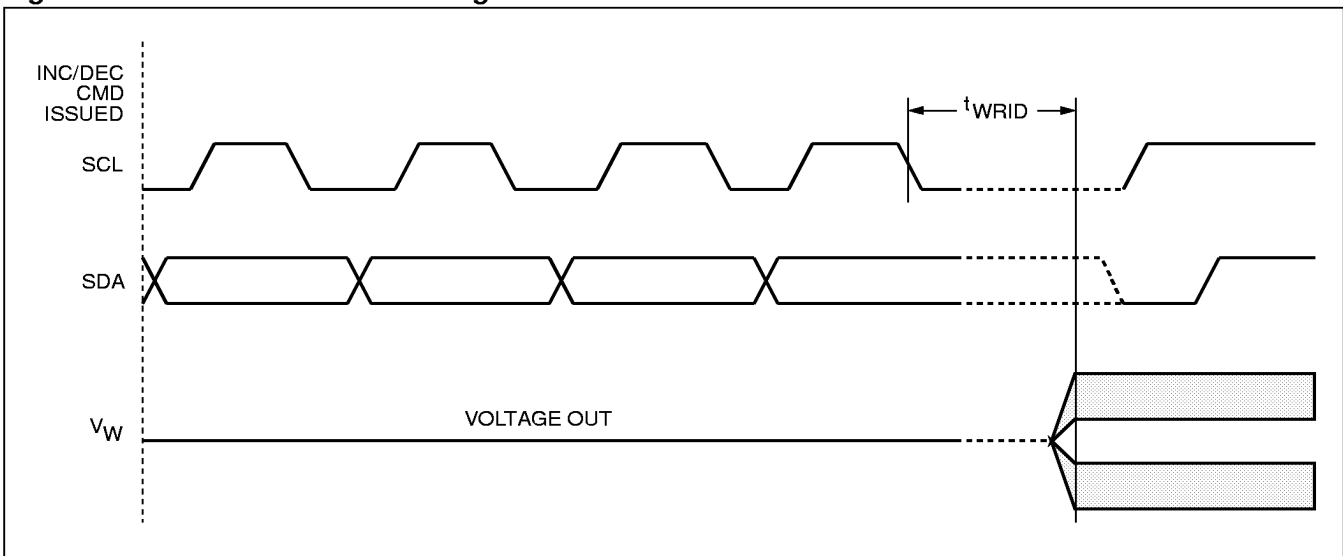

Figure 6. Increment/Decrement Timing Limits



X9408

Figure 7. Acknowledge Response from Receiver

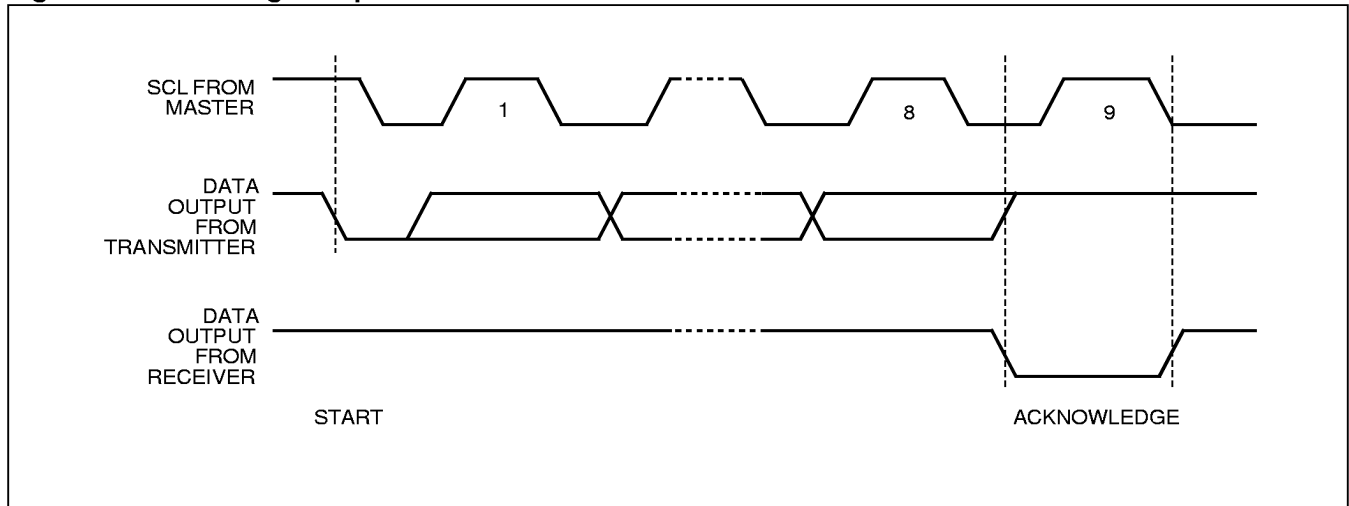
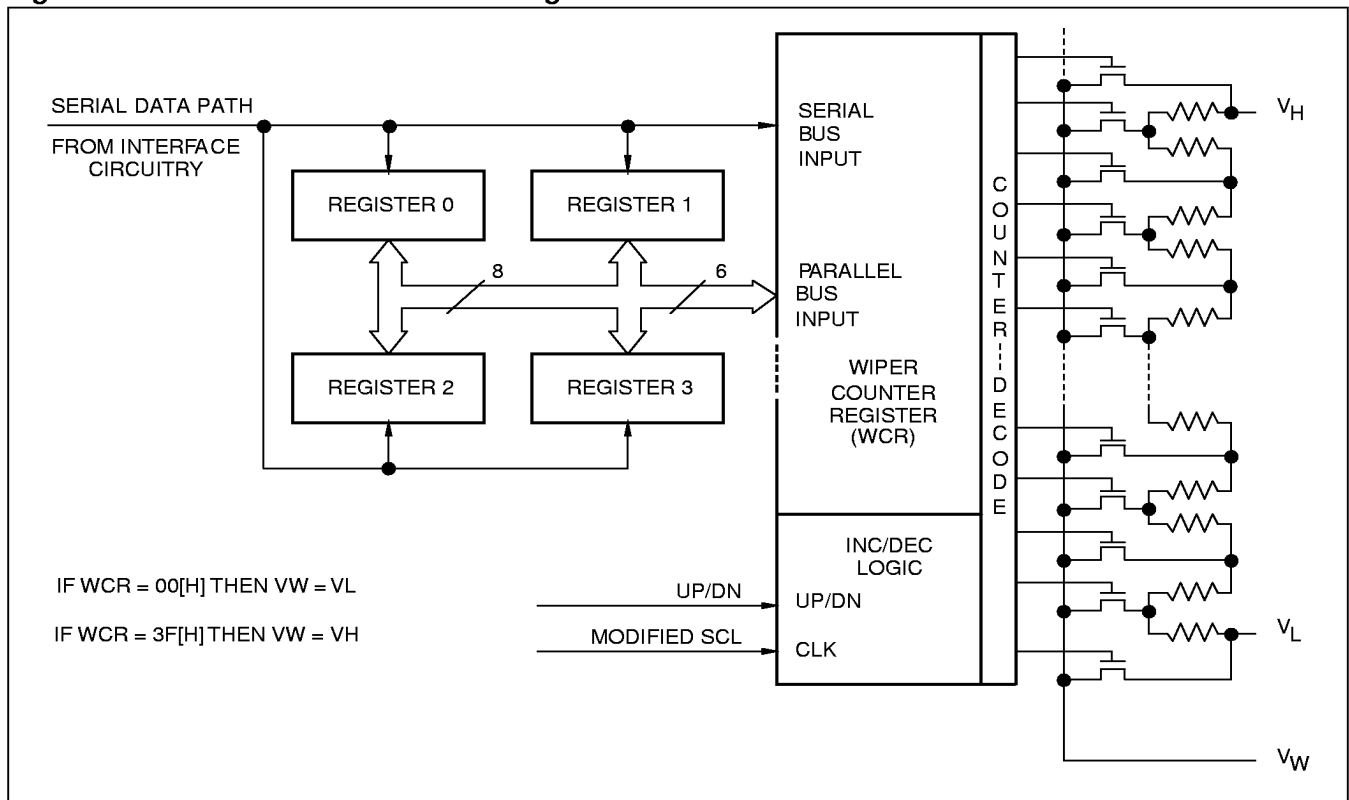

Figure 8. Detailed Potentiometer Block Diagram



X9408

DETAILED OPERATION

All EEPOT potentiometers share the serial interface and share a common architecture. Each potentiometer has a Wiper Counter Register and four data registers. A detailed discussion of the register organization and array operation follows.

Wiper Counter Register

The X9408 contains four Wiper Counter Registers, one for each EEPOT potentiometer. The Wiper Counter Register can be envisioned as a 6-bit parallel and serial load counter with its outputs decoded to select one of sixty-four switches along its resistor array. The contents of the WCR can be altered in four ways: it may be written directly by the host via the Write Wiper Counter Register instruction (serial load); it may be written indirectly by transferring the contents of one of four associated data registers via the XFR Data Register instruction (parallel load); it can be modified one step at a time by the Increment/ Decrement instruction. Finally, it is loaded with the contents of its data register zero (R0) upon power-up.

The WCR is a volatile register; that is, its contents are lost when the X9408 is powered-down. Although the register is automatically loaded with the value in R0 upon power-up, it should be noted this may be different from the value present at power-down.

Data Registers

Each potentiometer has four nonvolatile data registers. These can be read or written directly by the host and data can be transferred between any of the four data registers and the control latch. It should be noted all operations changing data in one of these registers is a nonvolatile operation and will take a maximum of 10ms.

If the application does not require storage of multiple settings for the potentiometer, these registers can be used as regular memory locations that could possibly store system parameters or user preference data.

Register Descriptions

Data Registers, (6-bit), non-volatile:

D5	D4	D3	D2	D1	D0
NV	NV	NV	NV	NV	NV
(MSB)			(LSB)		

Four 6-bit Data Registers for each EEPOT. (sixteen 6-bit registers in total).

- {D5~D0}: These bits are for general purpose not volatile data storage or for storage of up to four different wiper values. The contents of Data Register 0 are automatically moved to the wiper counter register on power-up.

Wiper Counter Register, (6-bit), volatile:

WP5	WP4	WP3	WP2	WP1	WP0
V	V	V	V	V	V
(MSB)			(LSB)		

One 6-bit Wiper Counter Register for each EEPOT. (Four 6-bit registers in total.)

- {D5~D0}: These bits specify the wiper position of the respective EEPOT. The Wiper Counter Register is loaded on power-up by the value in Data Register 0. The contents of the WCR can be loaded from any of the other Data Register or directly. The contents of the WCR can be saved in a DR.

X9408

Instruction Format

- Notes:** (1) "MACK"/"SACK": stands for the acknowledge sent by the master/slave.
 (2) "A3 ~ A0": stands for the device addresses sent by the master.
 (3) "X": indicates that it is a "0" for testing purpose but physically it is a "don't care" condition.
 (4) "I": stands for the increment operation, SDA held high during active SCL phase (high).
 (5) "D": stands for the decrement operation, SDA held low during active SCL phase (high).

Read Wiper Counter Register

S T A R T	device type identifier				device addresses				S A C K	instruction opcode				wiper addresses				S A C K	wiper position (sent by slave on SDA)							M A C K	S T O P
	0	1	0	1	A3	A2	A1	A0		1	0	0	1	0	0	P	P		0	0	W	W	W	W	W		
																			5	4	3	2	1	0			

Write Wiper Counter Register

S T A R T	device type identifier				device addresses				S A C K	instruction opcode				wiper addresses				S A C K	wiper position (sent by master on SDA)							S A C K	S T O P
	0	1	0	1	A3	A2	A1	A0		1	0	1	0	0	0	P	P		0	0	W	W	W	W	W		
																			5	4	3	2	1	0			

Read Data Register

S T A R T	device type identifier				device addresses				S A C K	instruction opcode				wiper addresses				S A C K	wiper position (sent by slave on SDA)							M A C K	S T O P
	0	1	0	1	A3	A2	A1	A0		1	0	1	1	R	R	P	P		0	0	W	W	W	W	W		
																			5	4	3	2	1	0			

Write Data Register

S T A R T	device type identifier				device addresses				S A C K	instruction opcode				wiper addresses				S A C K	wiper position (sent by master on SDA)							S A C K	S T O P	HIGH-VOLTAGE WRITE CYCLE
	0	1	0	1	A3	A2	A1	A0		1	1	0	0	R	R	P	P		0	0	W	W	W	W	W			
																			5	4	3	2	1	0				

XFR Data Register to Wiper Counter Register

S T A R T	device type identifier				device addresses				S A C K	instruction opcode				wiper addresses				S A C K	S T O P							
	0	1	0	1	A3	A2	A1	A0		1	1	0	1	R	R	P	P									

X9408

Write Wiper Counter Register to Data Register

S T A R T	device type identifier				device addresses				S A C K	instruction opcode				wiper addresses				S A C K	S T O P	HIGH-VOLTAGE WRITE CYCLE			
	0	1	0	1	A	3	A	2		A	1	A	0	1	1	1	0				R	1	R

Increment/Decrement Wiper Counter Register

S T A R T	device type identifier				device addresses				S A C K	instruction opcode				wiper addresses				S A C K	increment/decrement (sent by master on SDA)				S T O P						
	0	1	0	1	A	3	A	2		A	1	A	0	0	0	1	0		0	0	P	1		P	0	I/D	I/D	.	.

Global XFR Data Register to Wiper Counter Register

S T A R T	device type identifier				device addresses				S A C K	instruction opcode				wiper addresses				S A C K	S T O P		
	0	1	0	1	A	3	A	2		A	1	A	0	0	0	0	1			R	1

Global XFR Wiper Counter Register to Data Register

S T A R T	device type identifier				device addresses				S A C K	instruction opcode				wiper addresses				S A C K	S T O P	HIGH-VOLTAGE WRITE CYCLE	
	0	1	0	1	A	3	A	2		A	1	A	0	1	0	0	0				R

SYMBOL TABLE

WAVEFORM	INPUTS	OUTPUTS
	Must be steady	Will be steady
	May change from Low to High	Will change from Low to High
	May change from High to Low	Will change from High to Low
	Don't Care: Changes Allowed	Changing: State Not Known
	N/A	Center Line is High Impedance

Guidelines for Calculating Typical Values of Bus Pull-Up Resistors

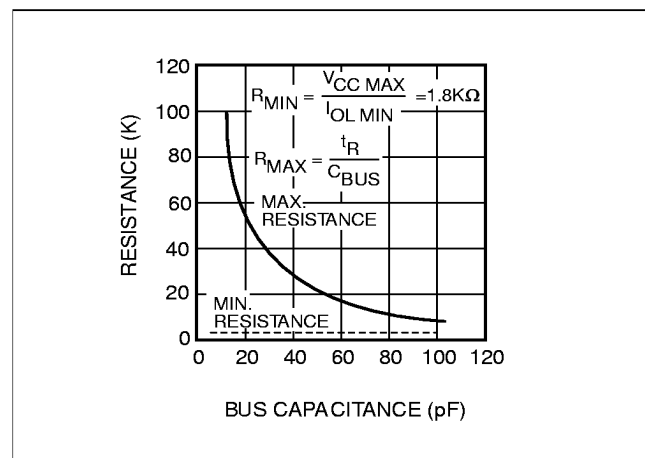

X9408

ABSOLUTE MAXIMUM RATINGS*

Temperature under Bias	-65°C to +135°C
Storage Temperature	-65°C to +150°C
Voltage on SDA, SCL or any Address Input with Respect to V _{SS}	-1V to +7V
Voltage on V+ (referenced to V _{SS})	10V
Voltage on V- (referenced to V _{SS})	-10V
(V+) - (V-)	12V
Any V _H	V+
Any V _L	V-
Lead Temperature (Soldering, 10 seconds).....	300°C

*COMMENT

Stresses above those listed under “Absolute Maximum Ratings” may cause permanent damage to the device. This is a stress rating only and the functional operation of the device at these or any other conditions above those listed in the operational sections of this specification is not implied. Exposure to absolute maximum rating conditions for extended periods may affect device reliability.

RECOMMENDED OPERATING CONDITIONS

Temp	Min.	Max.
Commercial	0°C	+70°C
Industrial	-40°C	+85°C

Device	Supply Voltage (V _{CC}) Limits
X9408	5V ±10%
X9408-2.7	2.7V to 5.5V

ANALOG CHARACTERISTICS (Over recommended operating conditions unless otherwise stated.)

Symbol	Parameter	Limits				Test Conditions
		Min.	Typ.	Max.	Units	
R _{TOTAL}	End to End Resistance	-20		+20	%	
	Power Rating			50	mW	25°C, each pot
I _W	Wiper Current	-3		+3	mA	
R _W	Wiper Resistance		150	250	Ω	Wiper Current = ± 1mA
V+	Voltage on V+ Pin	X9408	+4.5	+5.5	V	
		X9408-2.7	+2.7	+5.5		
V-	Voltage on V- Pin	X9408	-5.5	-4.5	V	
		X9408-2.7	-5.5	-2.7		
V _{TERM}	Voltage on any V _H or V _L Pin	V-		V+	V	
	Noise		-140		dBV	Ref: 1kHz
	Resolution ⁽⁴⁾		1.6		%	
	Absolute Linearity ⁽¹⁾	-1		+1	Ml ⁽³⁾	V _{w(n)(actual)} - V _{w(n)(expected)}
	Relative Linearity ⁽²⁾	-0.2		+0.2	Ml ⁽³⁾	V _{w(n+1)} - [V _{w(n)} + Ml]
	Temperature Coefficient of Resistance		±300		ppm/°C	

X9408

D.C. OPERATING CHARACTERISTICS (Over the recommended operating conditions unless otherwise specified.)

Symbol	Parameter	Limits				Test Conditions
		Min.	Typ.	Max.	Units	
I _{CC1}	V _{CC} Supply Current (Nonvolatile Write)		1		mA	f _{SCL} = 400KHz, SDA = Open, Other Inputs = V _{SS}
I _{CC2}	V _{CC} Supply Current (Move Wiper, Write, Read)			100	μA	f _{SCL} = 400KHz, SDA = Open, Other Inputs = V _{SS}
I _{SB}	V _{CC} Current (Standby)			1	μA	SCL = SDA = V _{CC} , Addr. = V _{SS}
I _{LI}	Input Leakage Current			10	μA	V _{IN} = V _{SS} to V _{CC}
I _{LO}	Output Leakage Current			10	μA	V _{OUT} = V _{SS} to V _{CC}
V _{IH}	Input HIGH Voltage	V _{CC} × 0.7		V _{CC} × 0.5	V	
V _{IL}	Input LOW Voltage	-0.5		V _{CC} × 0.1	V	
V _{OL}	Output LOW Voltage			0.4	V	I _{OL} = 3mA

- Notes:**
- (1) Absolute Linearity is utilized to determine actual wiper voltage versus expected voltage as determined by wiper position when used as a potentiometer.
 - (2) Relative Linearity is utilized to determine the actual change in voltage between two successive tap positions when used as a potentiometer. It is a measure of the error in step size.
 - (3) MI = RTOT/63 or (V_H - V_L)/63, single pot
 - (4) Max. = all four arrays cascaded together, Typical = individual array resolutions.

ENDURANCE AND DATA RETENTION

Parameter	Min.	Units
Minimum Endurance	100,000	Data Changes per Register
Data Retention	100	Years

CAPACITANCE

Symbol	Test	Max.	Units	Test Conditions
C _{I/O} ⁽⁵⁾	Input/Output Capacitance (SDA)	8	pF	V _{I/O} = 0V
C _{IN} ⁽⁵⁾	Input Capacitance (A0, A1, A2, A3, and SCL)	6	pF	V _{IN} = 0V

POWER-UP TIMING

Symbol	Parameter	Max.	Units
t _{PU_R} ⁽⁶⁾	Power-up to Initiation of Read Operation	1	ms
t _{PU_W} ⁽⁶⁾	Power-up to Initiation of Write Operation	5	ms

A.C. TEST CONDITIONS

Input Pulse Levels	V _{CC} × 0.1 to V _{CC} × 0.9
Input Rise and Fall Times	10ns
Input and Output Timing Level	V _{CC} × 0.5

- Notes:**
- (5) This parameter is periodically sampled and not 100% tested
 - (6) t_{PU_R} and t_{PU_W} are the delays required from the time the third (last) power supply (V_{CC}, V₊ or V₋) is stable until the specific instruction can be issued. These parameters are periodically sampled and not 100% tested.
 - (7) The bias order of power supply (V_{CC}, V₊ and V₋) don't care.

EQUIVALENT A.C. LOAD CIRCUIT

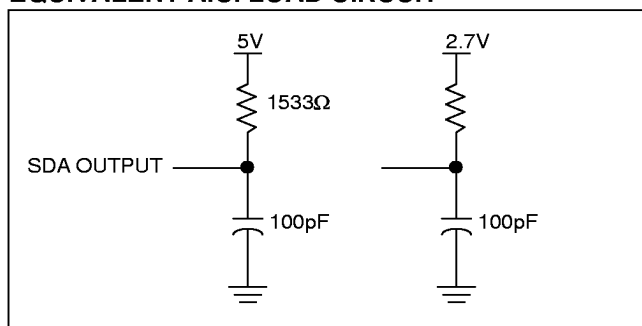

X9408

AC TIMING (over recommended operating condition)

Symbol	Parameter	Min.	Max.	Units
f_{SCL}	Clock Frequency		400	KHz
t_{CYC}	Clock Cycle Time	2500		ns
t_{HIGH}	Clock High Time	600		ns
t_{LOW}	Clock Low Time	1300		ns
$t_{SU:STA}$	Start Setup Time	600		ns
$t_{HD:STA}$	Start Hold Time	600		ns
$t_{SU:STO}$	Stop Setup Time	600		ns
$t_{SU:DAT}$	SDA Data Input Setup Time	100		ns
$t_{HD:DAT}$	SDA Data Input Hold Time	30		ns
t_R	SCL and SDA Rise Time		300	ns
t_F	SCL and SDA Fall Time		300	ns
t_{AA}	SCL Low to SDA Data Output Valid Time	100	900	ns
t_{DH}	SDA Data Output Hold Time	50		ns
T_I	Noise Suppression Time Constant at SCL and SDA inputs	50		ns
t_{BUF}	Bus Free Time (Prior to Any Transmission)	1300		ns
$t_{SU:WPA}$	\overline{WP} , A0, A1, A2 and A3 Setup Time	0		ns
$t_{HD:WPA}$	\overline{WP} , A0, A1, A2 and A3 Hold Time	0		ns

HIGH-VOLTAGE WRITE CYCLE TIMING

Symbol	Parameter	Typ.	Max.	Units
t_{WR}	High-voltage Write Cycle Time (Store Instructions)	5	10	ms

EOPOT TIMING

Symbol	Parameter	Min.	Max.	Units
t_{WRPO}	Wiper Response Time After The Third (Last) Power Supply Is Stable		10	μ S
t_{WRL}	Wiper Response Time After Instruction Issued (All Load Instructions)		10	μ S
t_{WRID}	Wiper Response Time From An Active SCL/SCK Edge (Increment/Decrement Instruction)		10	μ S

Notes: (8) A device must internally provide a hold time of at least 300ns for the SDA signal in order to bridge the undefined region of the falling edge of SCL.

X9408

TIMING DIAGRAMS

FIGURE 1. START and STOP Timing

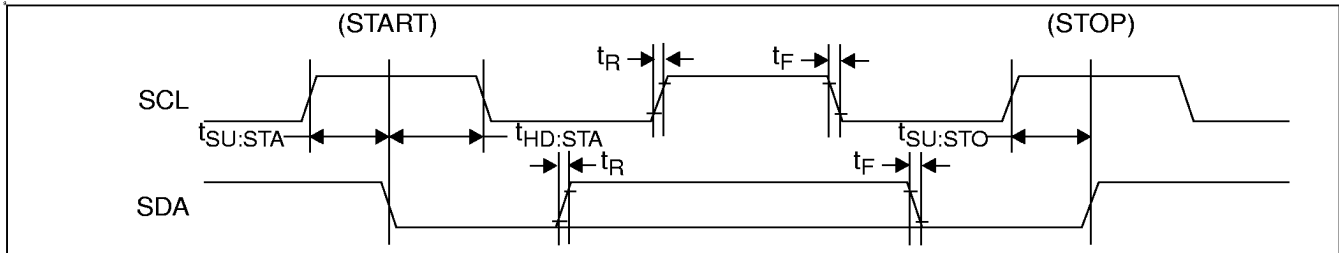

FIGURE 2. Input Timing

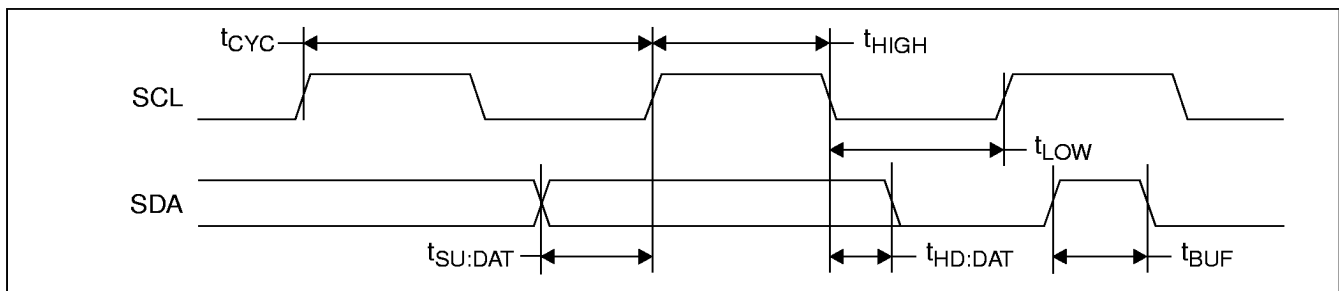

FIGURE 3. Output Timing

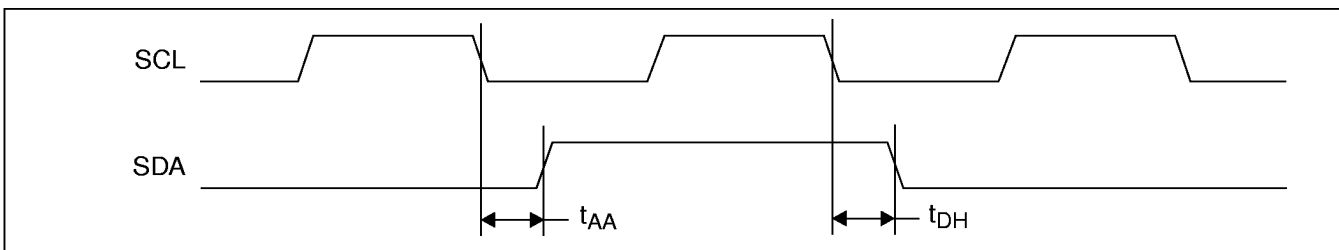
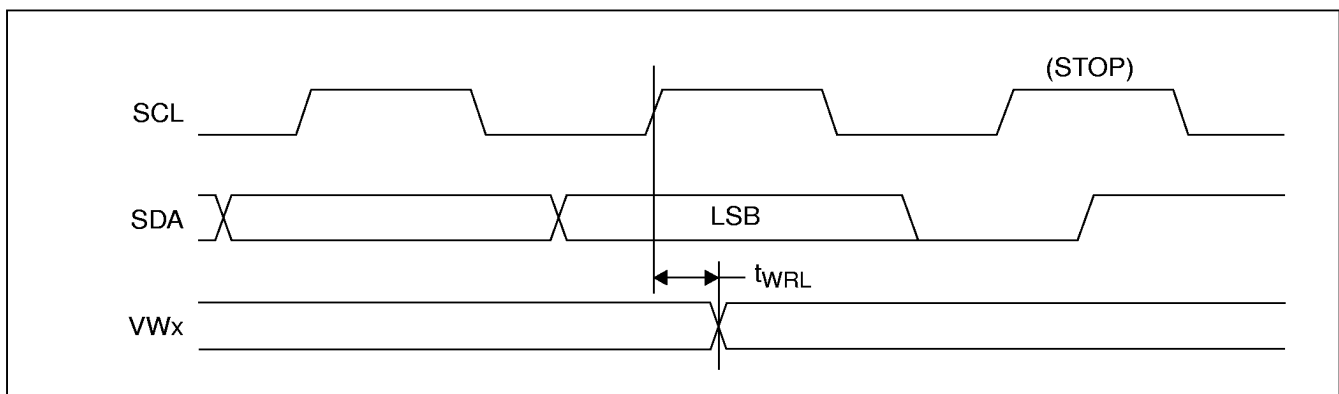

FIGURE 4. EEPROM Timing (for All Load Instructions)



X9408

FIGURE 5. EEPROM Timing (for Increment/Decrement Instruction)

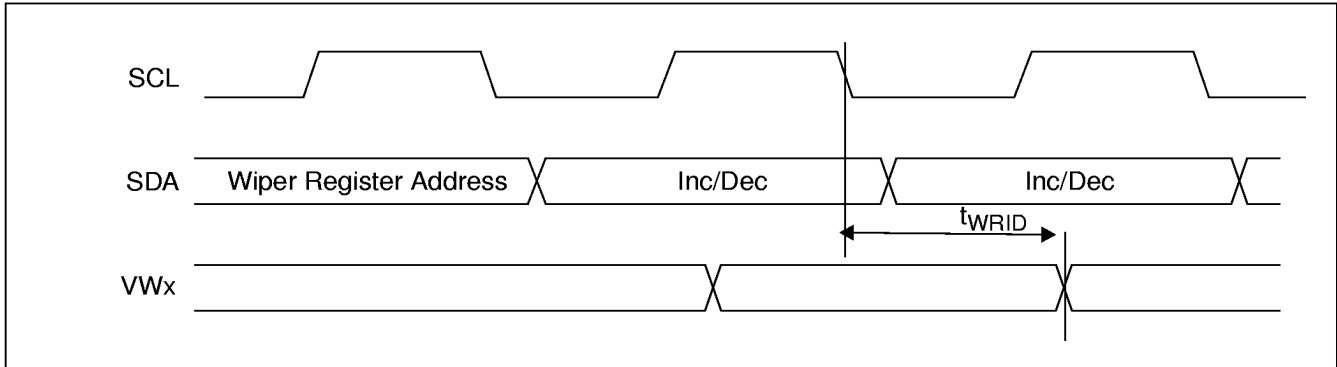
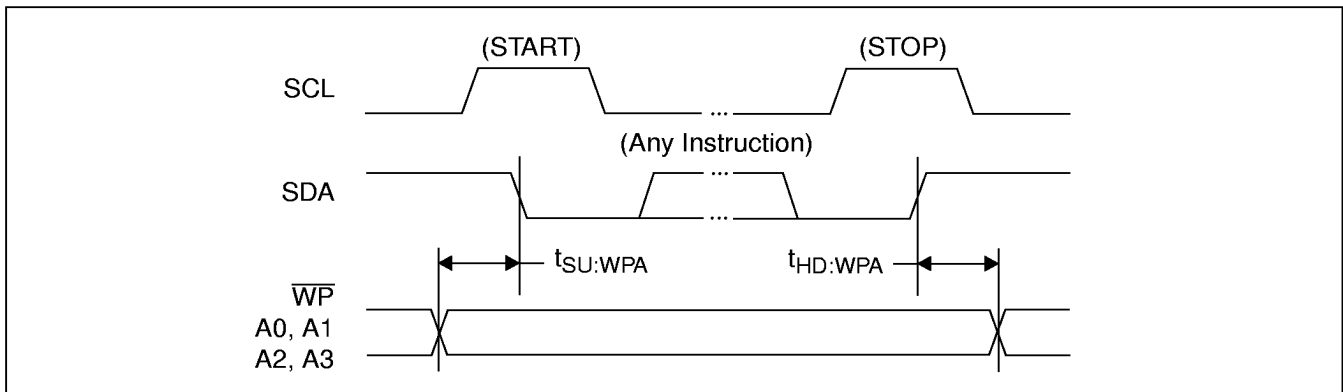
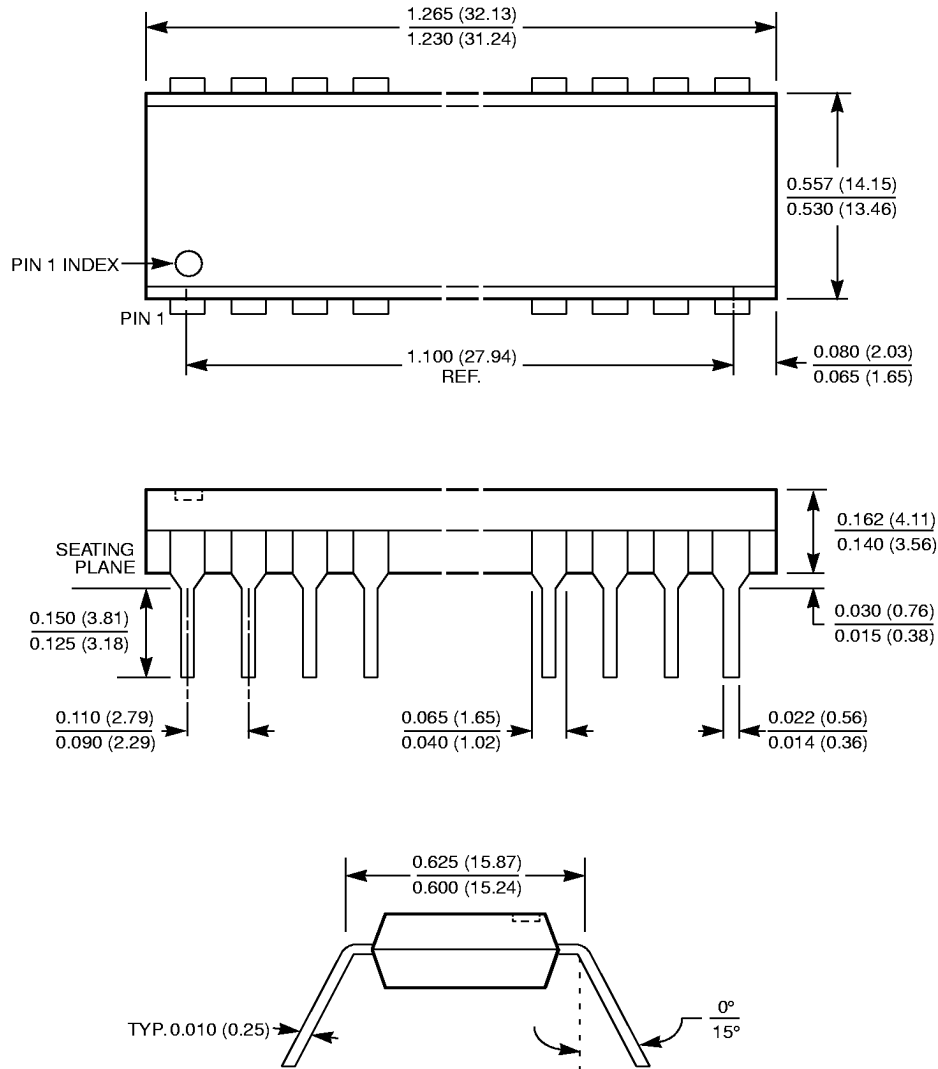

FIGURE 6. Write Protect and Device Address Pins Timing



24-LEAD PLASTIC DUAL IN-LINE PACKAGE TYPE P



- NOTE:**
1. ALL DIMENSIONS IN INCHES (IN PARENTHESES IN MILLIMETERS)
 2. PACKAGE DIMENSIONS EXCLUDE MOLDING FLASH

24-LEAD PLASTIC SMALL OUTLINE GULL WING PACKAGE TYPE S

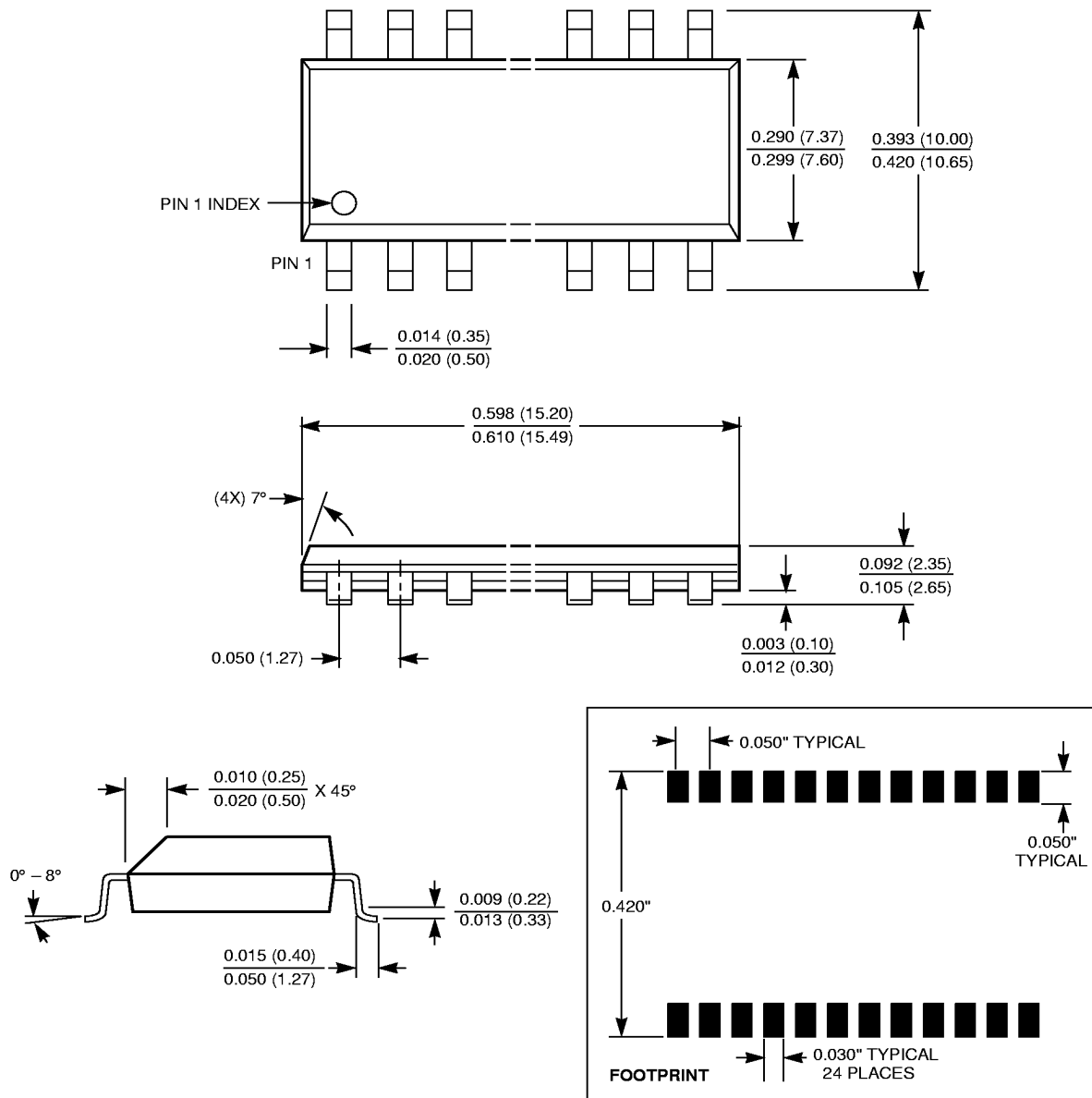

NOTE: ALL DIMENSIONS IN INCHES (IN PARENTHESES IN MILLIMETERS)

24-LEAD PLASTIC, TSSOP PACKAGE TYPE V

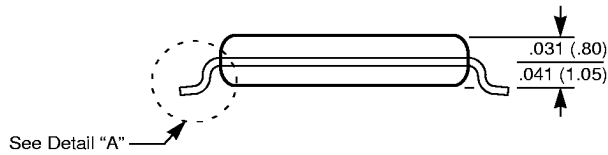
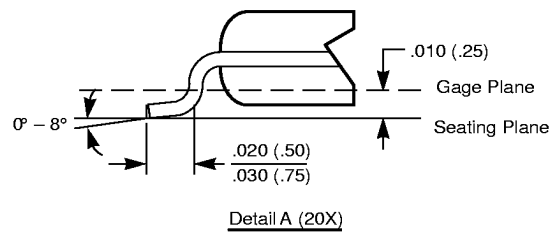
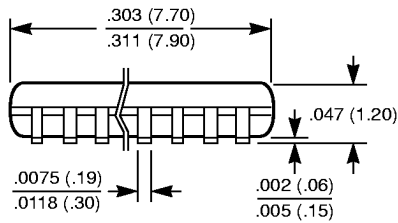
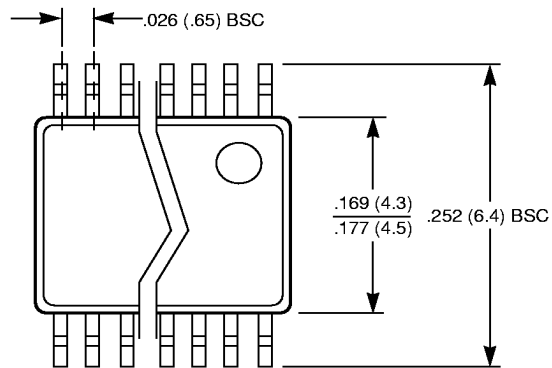

NOTE: ALL DIMENSIONS IN INCHES (IN PARENTHESES IN MILLIMETERS)

X9408

ORDERING INFORMATION

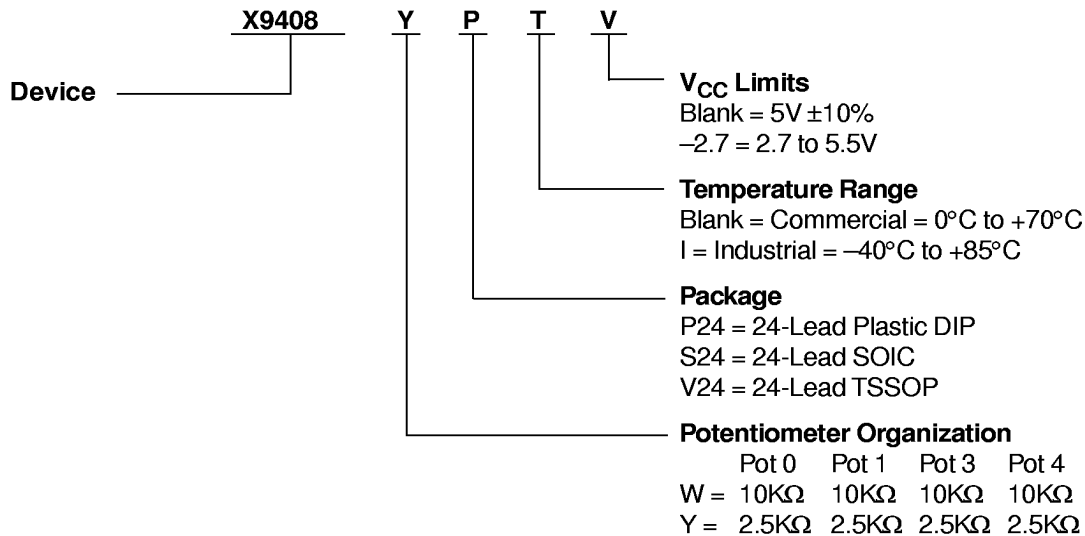

LIMITED WARRANTY

Devices sold by Xicor, Inc. are covered by the warranty and patent indemnification provisions appearing in its Terms of Sale only. Xicor, Inc. makes no warranty, express, statutory, implied, or by description regarding the information set forth herein or regarding the freedom of the described devices from patent infringement. Xicor, Inc. makes no warranty of merchantability or fitness for any purpose. Xicor, Inc. reserves the right to discontinue production and change specifications and prices at any time and without notice.

Xicor, Inc. assumes no responsibility for the use of any circuitry other than circuitry embodied in a Xicor, Inc. product. No other circuits, patents, licenses are implied.

U.S. PATENTS

Xicor products are covered by one or more of the following U.S. Patents: 4,263,664; 4,274,012; 4,300,212; 4,314,265; 4,326,134; 4,393,481; 4,404,475; 4,450,402; 4,486,769; 4,488,060; 4,520,461; 4,533,846; 4,599,706; 4,617,652; 4,668,932; 4,752,912; 4,829, 482; 4,874, 967; 4,883, 976. Foreign patents and additional patents pending.

LIFE RELATED POLICY

In situations where semiconductor component failure may endanger life, system designers using this product should design the system with appropriate error detection and correction, redundancy and back-up features to prevent such an occurrence.

Xicor's products are not authorized for use in critical components in life support devices or systems.

1. Life support devices or systems are devices or systems which, (a) are intended for surgical implant into the body, or (b) support or sustain life, and whose failure to perform, when properly used in accordance with instructions for use provided in the labeling, can be reasonably expected to result in a significant injury to the user.
2. A critical component is any component of a life support device or system whose failure to perform can be reasonably expected to cause the failure of the life support device or system, or to affect its safety or effectiveness.