

Buck chopper NPT IGBT Power Module

$V_{CES} = 600V$
 $I_C = 350A @ T_c = 80^\circ C$

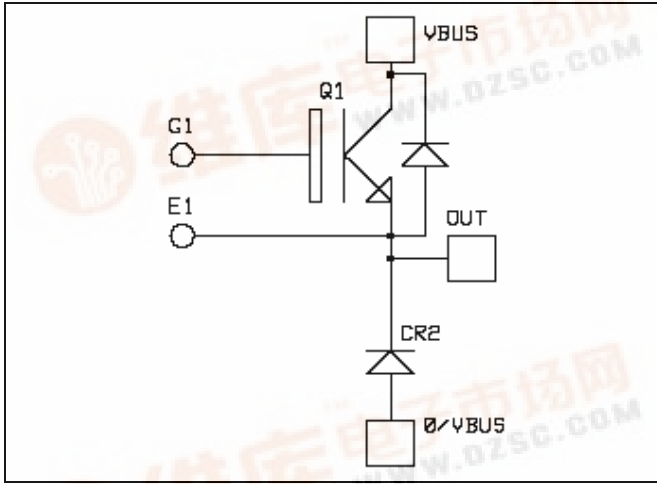

Application

- AC and DC motor control
- Switched Mode Power Supplies

Features

- Non Punch Through (NPT) THUNDERBOLT IGBT®
 - Low voltage drop
 - Low tail current
 - Switching frequency up to 100 kHz
 - Soft recovery parallel diodes
 - Low diode VF
 - Low leakage current
 - Avalanche energy rated
 - RBSOA and SCSOA rated
- Kelvin emitter for easy drive
- Very low stray inductance
 - Symmetrical design
 - M5 power connectors
- High level of integration

Benefits

- Outstanding performance at high frequency operation
- Stable temperature behavior
- Very rugged
- Direct mounting to heatsink (isolated package)
- Low junction to case thermal resistance
- Easy paralleling due to positive TC of VCESat
- Low profile

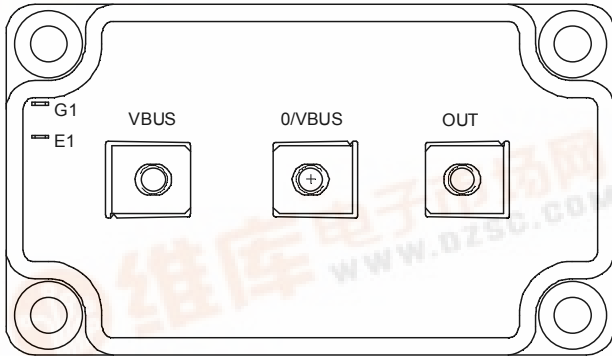

Absolute maximum ratings

| Symbol | Parameter | Max ratings | Unit |
|-----------|---------------------------------------|---------------------|--------------|
| V_{CES} | Collector - Emitter Breakdown Voltage | 600 | V |
| I_C | Continuous Collector Current | $T_c = 25^\circ C$ | 430 |
| | | $T_c = 80^\circ C$ | 350 |
| I_{CM} | Pulsed Collector Current | $T_c = 25^\circ C$ | 1225 |
| V_{GE} | Gate - Emitter Voltage | ± 20 | V |
| P_D | Maximum Power Dissipation | $T_c = 25^\circ C$ | 1562 |
| RBSOA | Reverse Bias Safe Operating Area | $T_j = 150^\circ C$ | 1225A @ 600V |

All ratings @ $T_j = 25^\circ\text{C}$ unless otherwise specified

Electrical Characteristics

| Symbol | Characteristic | Test Conditions | Min | Typ | Max | Unit |
|--------------|---------------------------------------|----------------------------------|---------------------------|-----|-----------|---------|
| BV_{CES} | Collector - Emitter Breakdown Voltage | $V_{GE} = 0V, I_C = 200\mu A$ | 600 | | | V |
| I_{CES} | Zero Gate Voltage Collector Current | $V_{GE} = 0V$ $V_{CE} = 600V$ | $T_j = 25^\circ\text{C}$ | | 200 | μA |
| | | | $T_j = 125^\circ\text{C}$ | | 4000 | |
| $V_{CE(on)}$ | Collector Emitter on Voltage | $V_{GE} = 15V$ $I_C = 360A$ | $T_j = 25^\circ\text{C}$ | 2.0 | 2.5 | V |
| | | | $T_j = 125^\circ\text{C}$ | 2.2 | | |
| $V_{GE(th)}$ | Gate Threshold Voltage | $V_{GE} = V_{CE}, I_C = 4mA$ | 3 | | 5 | V |
| I_{GES} | Gate - Emitter Leakage Current | $V_{GE} = \pm 20V, V_{CE} = 0V$ | | | ± 300 | nA |

Dynamic Characteristics

| Symbol | Characteristic | Test Conditions | Min | Typ | Max | Unit |
|--------------|------------------------------|---|-----|------|-----|------|
| C_{ies} | Input Capacitance | $V_{GE} = 0V$ | | 17.2 | | nF |
| C_{oes} | Output Capacitance | $V_{CE} = 25V$ | | 1.88 | | |
| C_{res} | Reverse Transfer Capacitance | $f = 1MHz$ | | 1.6 | | |
| Q_g | Total gate Charge | $V_{GS} = 15V$ | | 1320 | | nC |
| Q_{ge} | Gate - Emitter Charge | $V_{Bus} = 300V$ | | 1160 | | |
| Q_{gc} | Gate - Collector Charge | $I_C = 360A$ | | 800 | | |
| $T_{d(on)}$ | Turn-on Delay Time | Inductive Switching (25°C) | | 26 | | ns |
| T_r | Rise Time | $V_{GE} = 15V$ | | 25 | | |
| $T_{d(off)}$ | Turn-off Delay Time | $V_{Bus} = 400V$ | | 150 | | |
| T_f | Fall Time | $I_C = 360A$ | | 30 | | |
| E_{on} | Turn-on Switching Energy ❶ | $R_G = 1.25\Omega$ | | 13.5 | | |
| E_{off} | Turn-off Switching Energy ❷ | | | 11.5 | | |
| $T_{d(on)}$ | Turn-on Delay Time | Inductive Switching (125°C) | | 26 | | ns |
| T_r | Rise Time | $V_{GE} = 15V$ | | 25 | | |
| $T_{d(off)}$ | Turn-off Delay Time | $V_{Bus} = 400V$ | | 170 | | |
| T_f | Fall Time | $I_C = 360A$ | | 40 | | |
| E_{on} | Turn-on Switching Energy ❶ | $R_G = 1.25\Omega$ | | 17.2 | | |
| E_{off} | Turn-off Switching Energy ❷ | | | 14 | | |

Reverse diode ratings and characteristics

| Symbol | Characteristic | Test Conditions | Min | Typ | Max | Unit |
|-------------|---------------------------------|---|---------------------------|------|-----|------|
| $I_{F(AV)}$ | Maximum Average Forward Current | 50% duty cycle $T_c = 80^\circ\text{C}$ | | 400 | | A |
| V_F | Diode Forward Voltage | $I_F = 400A$ | | 1.6 | 1.8 | V |
| | | $I_F = 800A$ | | 1.9 | | |
| | | $I_F = 400A$ $T_j = 125^\circ\text{C}$ | | 1.4 | | |
| t_{rr} | Reverse Recovery Time | $I_F = 400A$ $V_R = 4400V$ $di/dt = 800A/\mu s$ | $T_j = 25^\circ\text{C}$ | 180 | | ns |
| | | | $T_j = 125^\circ\text{C}$ | 220 | | |
| Q_{rr} | Reverse Recovery Charge | $I_F = 400A$ $V_R = 400V$ $di/dt = 800A/\mu s$ | $T_j = 25^\circ\text{C}$ | 1560 | | nC |
| | | | $T_j = 125^\circ\text{C}$ | 5800 | | |

❶ E_{on} includes diode reverse recovery

❷ In accordance with JEDEC standard JESD24-1

Typical Performance Curve

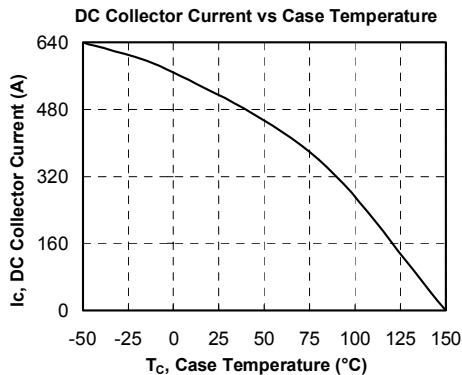
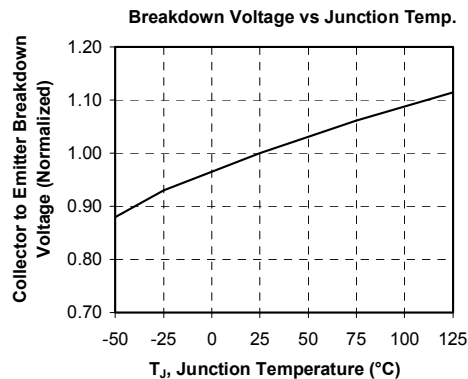
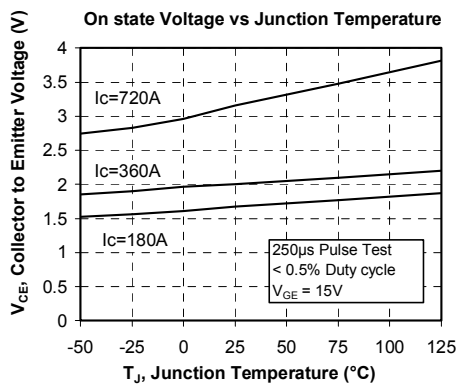
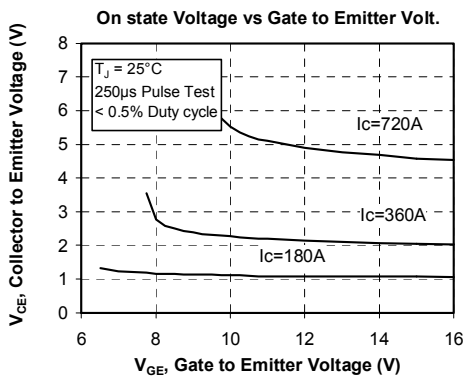
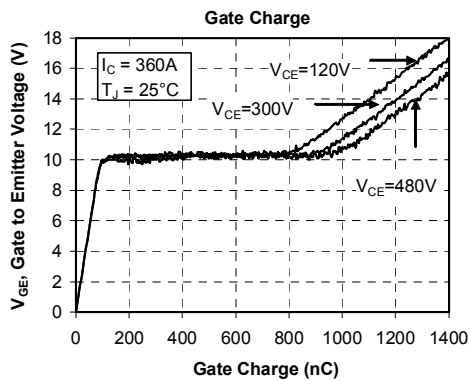
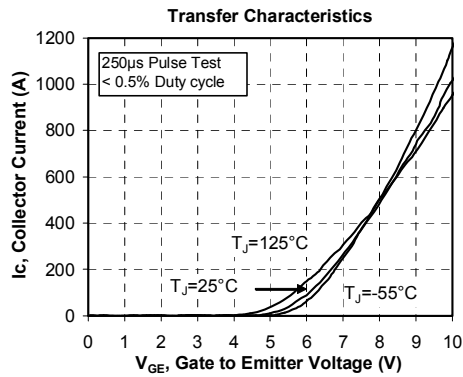
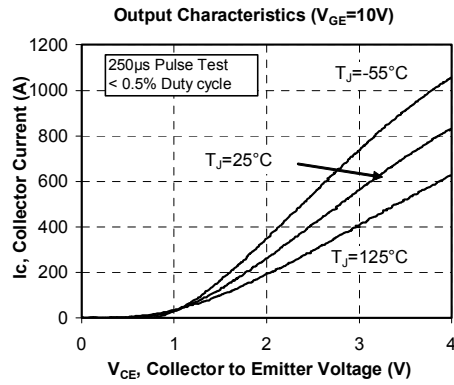
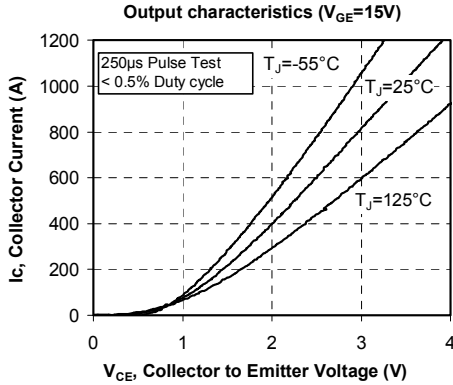

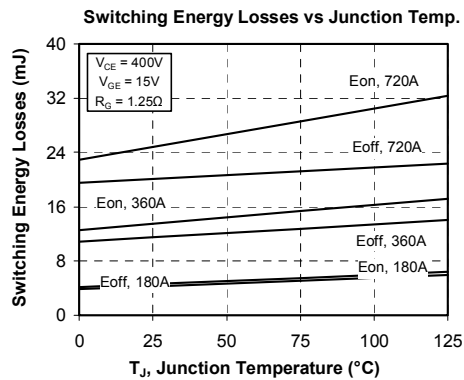
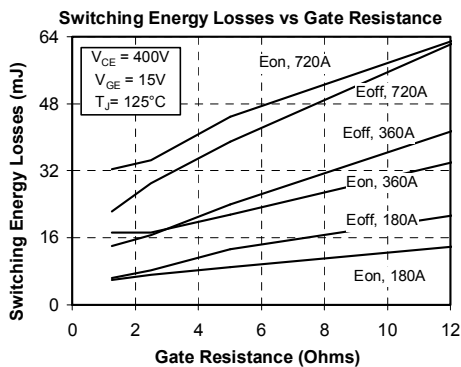
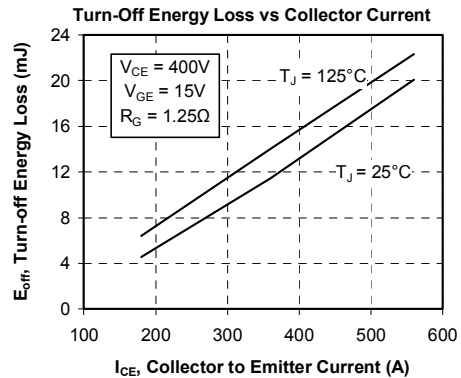
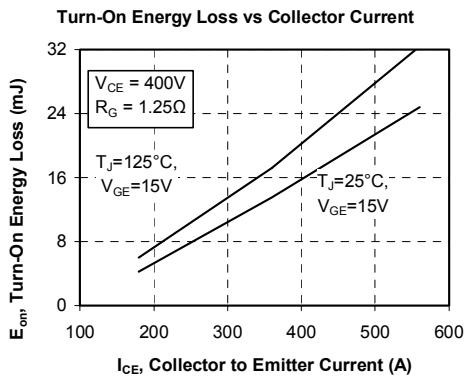
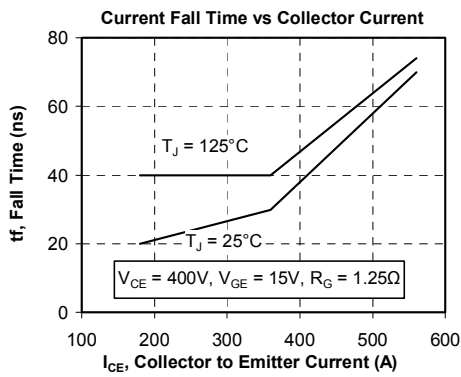
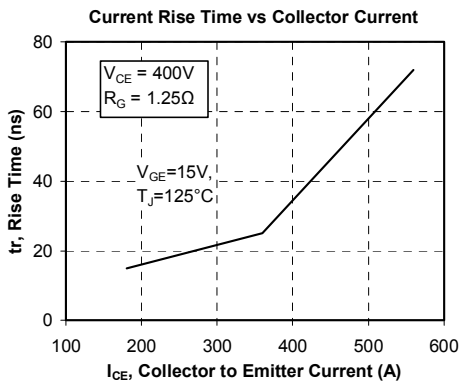
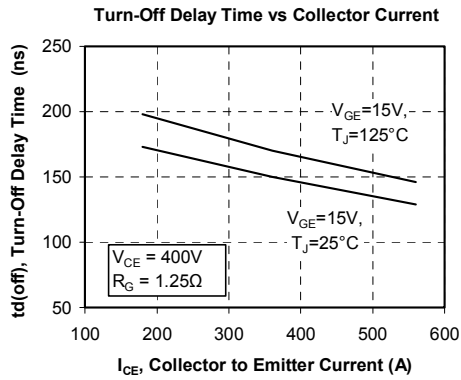
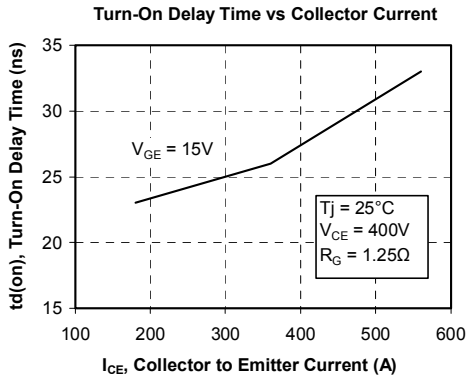

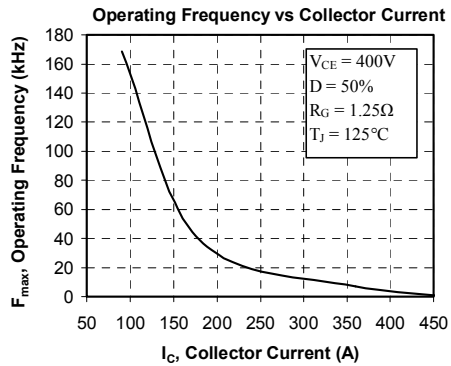
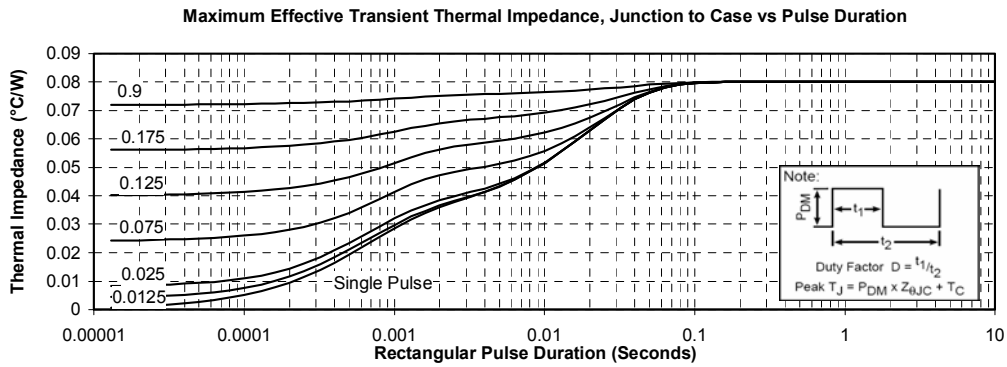
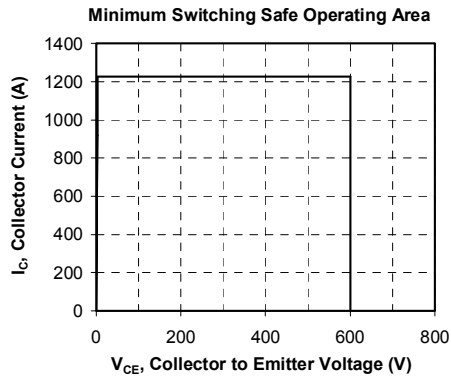
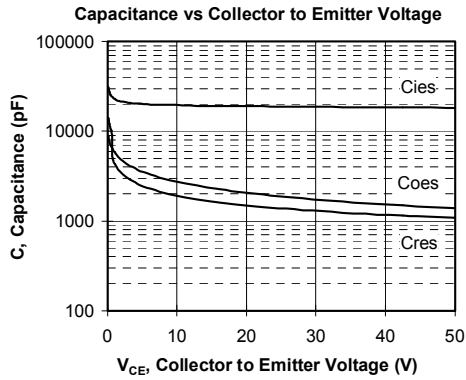

APT reserves the right to change, without notice, the specifications and information contained herein

APT's products are covered by one or more of U.S patents 4,895,810 5,045,903 5,089,434 5,182,234 5,019,522 5,262,336 6,503,786 5,256,583 4,748,103 5,283,202 5,231,474 5,434,095 5,528,058 and foreign patents. U.S and Foreign patents pending. All Rights Reserved.