

SMD Type Transistors

Silicon PNP Epitaxial Planar Type
2SB933

Features

- Low collector-emitter saturation voltage $V_{CE(sat)}$.
- Satisfactory linearity of forward current transfer ratio h_{FE} .
- Large collector current I_C .

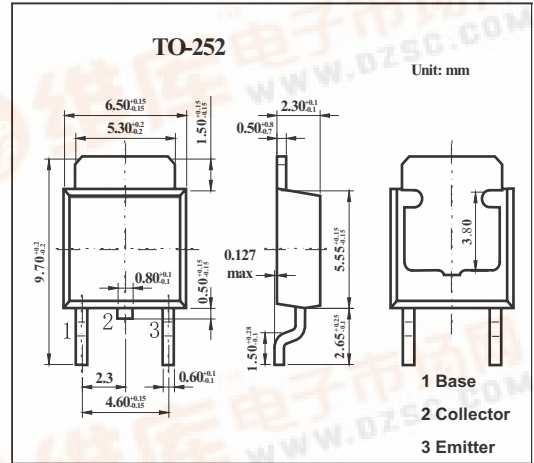

Absolute Maximum Ratings $T_a = 25^\circ C$

Parameter	Symbol	Rating	Unit
Collector-base voltage	V_{CBO}	-130	V
Collector-emitter voltage	V_{CEO}	-80	V
Emitter-base voltage	V_{EBO}	-7	V
Collector current	I_C	-5	A
Peak collector current	I_{CP}	-10	A
Collector power dissipation	P_C	1.3	W
Junction temperature	T_j	150	$^\circ C$
Storage temperature	T_{stg}	-55 to +150	$^\circ C$

Electrical Characteristics $T_a = 25^\circ C$

Parameter	Symbol	Testconditions	Min	Typ	Max	Unit
Collector-emitter voltage	V_{CEO}	$I_C = -10mA, I_B = 0$	-80			V
Collector-base cutoff current	I_{CBO}	$V_{CB} = -100 V, I_E = 0$			-10	μA
Emitter-base cutoff current	I_{EBO}	$V_{EB} = -5 V, I_C = 0$			-50	μA
Forward current transfer ratio	h_{FE}	$V_{CE} = -2 V, I_C = -2 A$	90		260	V
		$V_{CE} = -2 V, I_C = -0.1 A$	45			
Base-emitter saturation voltage	$V_{BE(sat)}$	$I_C = -4 A, I_B = -0.2 A$			-1.5	V
Collector-emitter saturation voltage	$V_{CE(sat)}$	$I_C = -4 A, I_B = -0.2 A$			-0.5	V
Transition frequency	f_T	$V_{CE} = -10 V, I_C = -0.5 A, f = 10 MHz$		30		MHz
Turn-on time	t_{on}	$I_C = -2 A, I_{B1} = -0.2 A, I_{B2} = 0.2 A, V_{CC} = -50 V$		0.13		μs
Storage time	t_{stg}			0.5		μs
Fall time	t_f			0.13		μs

hFE Classification

Rank	Q	P
h_{FE}	90~180	130~260

