

SMD Type MOSFET

MOS Field Effect Power Transistors  
2SJ324

Features

- Low on-state resistance  
 $R_{DS(on)}=0.18\ \Omega$  ( $V_{GS}=-10V, I_D=-1A$ )  
 $R_{DS(on)}=0.36\ \Omega$  ( $V_{GS}=-4V, I_D=-0.8A$ )
- Built-in G-S Gate Protection Diode

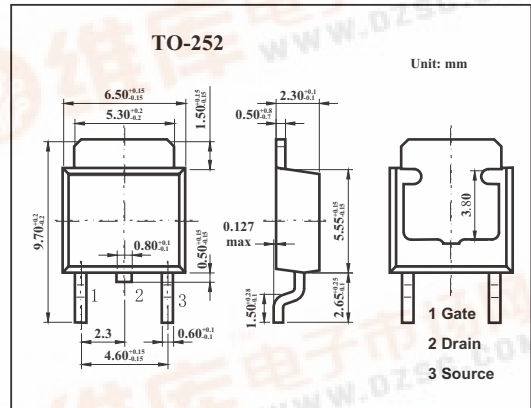
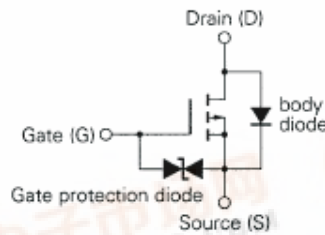

Absolute Maximum Ratings  $T_a = 25^\circ C$

Parameter	Symbol	Rating	Unit
Drain to source voltage	$V_{DS}$	-30	V
Gate to source voltage (DC)	$V_{GS}$	-20,+10	V
Gate to source voltage (AC)	$V_{GSS}$	$\pm 20$	V
Drain current (DC)	$I_D$	$\pm 2.0$	A
Drain current(pulse) *	$I_D$	$\pm 8.0$	A
Power dissipation	$P_D$	$T_c=25^\circ C$	20
		$T_A=25^\circ C$	1.0
Channel temperature	$T_{ch}$	150	$^\circ C$
Storage temperature	$T_{stg}$	-55 to +150	$^\circ C$

\*  $PW \leq 10\ \mu s; d \leq 1\%$ .

## 2SJ324

## ■ Electrical Characteristics Ta = 25°C

Parameter	Symbol	Testconditons	Min	Typ	Max	Unit
Drain to source breakdown voltage	V <sub>DSS</sub>	I <sub>D</sub> =-10mA, V <sub>GS</sub> =0	-200			V
Gate to source breakdown voltage	V <sub>GSS</sub>	I <sub>G</sub> =±100 μA, V <sub>DS</sub> =0	±20			V
Drain cut-off current	I <sub>DSS</sub>	V <sub>DS</sub> =-30V, V <sub>GS</sub> =0			-10	μA
Gate leakage current	I <sub>GSS</sub>	V <sub>GS</sub> =±16V, V <sub>DS</sub> =0			±10	μA
Gate cut-off voltage	V <sub>GS(off)</sub>	V <sub>DS</sub> =-10V, I <sub>D</sub> =-1mA	-1.0	-1.5	-2.0	V
Forward transfer admittance	Y <sub>fs</sub>	V <sub>DS</sub> =-10V, I <sub>D</sub> =-1A	1.0	1.9		S
Drain to source on-state resistance	R <sub>DS(on)</sub>	V <sub>GS</sub> =-10V, I <sub>D</sub> =-1A		0.18	0.25	Ω
		V <sub>GS</sub> =-4V, I <sub>D</sub> =-0.8A		0.36	0.52	Ω
Input capacitance	C <sub>iss</sub>	V <sub>DS</sub> =-10V, V <sub>GS</sub> =0, f=1MHZ		330		pF
Output capacitance	C <sub>oss</sub>			290		pF
Reverse transfer capacitance	C <sub>rss</sub>			105		pF
Turn-on delay time	t <sub>d(on)</sub>	V <sub>GS(on)</sub> =-10V, V <sub>DD</sub> =-15V, I <sub>D</sub> =-1A R <sub>L</sub> =15 Ω, R <sub>G</sub> =10 Ω		7		ns
Rise time	t <sub>r</sub>			35		ns
Turn-off delay time	t <sub>d(off)</sub>			40		ns
Fall time	t <sub>f</sub>			30		ns
Total Gate Charge	Q <sub>g</sub>	V <sub>GS</sub> =-10V, I <sub>D</sub> =-2.0A, V <sub>DD</sub> =-24V		12		nC
Gate to Source Charge	Q <sub>GS</sub>			1.5		nC
Gate Drain Charge	Q <sub>GD</sub>			4.5		nC
Body Diode Forward Voltage	V <sub>F</sub>	I <sub>F</sub> =2.0A, V <sub>GS</sub> =0		0.9		V
Reverse Recovery time	t <sub>rr</sub>	I <sub>F</sub> =2.0A, V <sub>GS</sub> =0, di/dt=50A/μs		50		ns
Reverse Recovery Charge	Q <sub>rr</sub>			40		nC