



MIC2755

Battery System Supervisor

Preliminary Information

General Description

The MIC2755 is composed of multiple comparators, a reset pulse generator, and logic. It is designed for monitoring the battery supply of portable digital systems, including PDAs and pagers.

The MIC2755 detects three different battery states: battery OK, low battery, and dead battery. The reset (/RST) output is asserted for at least 700ms when a fresh battery is inserted. The nonmaskable interrupt output (/NMI) is asserted when the battery voltage is below the NTH threshold, indicating that high-power system operations should not occur. If and when battery voltage falls below the power-off threshold (PTH), the reset output is asserted and latched, inhibiting system operation until the battery is replaced or recharged.

All three voltage thresholds are set using external resistors. A manual reset function can be implemented by connecting a switch directly to the power on reset/manual reset [RTH(/MR)] input. Internal circuitry detects switch activation and generates a minimum 175ms debounced reset signal. The MIC2755's power supply input is separate from the detector inputs to allow it to be powered from a down-stream voltage, such as the output of a boost converter.

Inputs and outputs can be pulled above V_{DD} (up to 7V absolute maximum) without adverse effects or excessive current draw.

Supply current is typically a low 2 μ A. Hysteresis is included on all voltage detectors to prevent chattering due to noise. The MIC2755 is available in the tiny 8-lead micro-small-outline package.

Features

- Optimized for PDAs, pagers and other hand-held devices.
- Detects multiple battery states:
 - battery OK
 - low battery
 - dead battery
- Adjustable voltage thresholds
- High accuracy $\pm 2\%$ voltage thresholds
- Reset generation at power-on (700ms min.)
- Debounced manual reset function
- Internal logic prevents chatter if battery voltage fluctuates
- Extremely low 2 μ A typical supply current
- I/Os can be pulled above V_{DD} (7V absolute maximum)
- Immune to brief power supply transients
- Low cost
- 8-lead MSOP

Applications

- PDAs
- Pagers
- Consumer electronics
- Embedded controllers
- Portable instruments
- Data loggers

Ordering Information

Part Number	Junction Temp. Range	Package
MIC2755BMM	-40°C to +85°C	8-pin MSOP

Typical Application

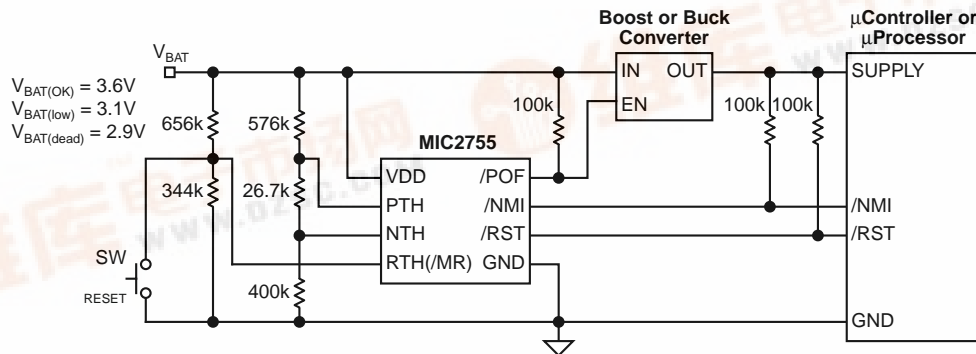

Supervised Boost Converter and Microcontroller or Microprocessor



Pin Configuration

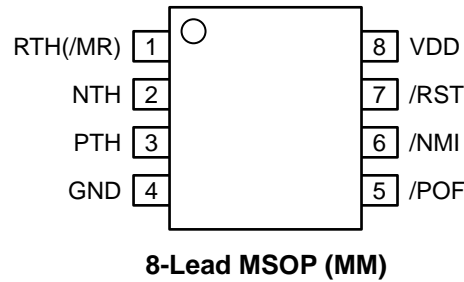

Pin Description

Pin Number	Pin Name	Pin Function
1	RTH(/MR)	Power-On Reset Threshold (Analog Input): Comparator input assigned to battery-OK condition detection. When the level on this pin first exceeds V_{REF} , the reset generator cycles. The /RST output is held low for a minimum of 700ms and the /POF threshold output is deasserted.
2	NTH	Nonmaskable Interrupt Threshold (Analog Input): Voltage monitor input assigned to “low battery” condition detection. When the level on this pin falls below V_{REF} , the /NMI output is asserted.
3	PTH	Power-Off Threshold (Analog Input): Voltage monitor input assigned to “dead battery” condition detection. When the level on this pin falls below V_{REF} , the /RST and /POF outputs are asserted. The condition is latched until a reset cycle occurs ($V_{RTH} > V_{REF}$).
4	GND	Ground: Power and signal return for all IC functions.
5	/POF	Power-off (Output): Active-low, open-drain output. Asserted and latched when $V_{PTH} < V_{REF}$, which is a “dead battery” condition. The system is held in reset until the battery is replaced and a power-on reset cycle occurs.
6	/NMI	Nonmaskable Interrupt (Output): Active-low, open-drain output. Asserted when $V_{NTH} < V_{REF}$, which is a “low battery” condition. This indicates high-power system operation should not be allowed.
7	/RST	Reset (Output): Active-low, open-drain output. Asserted for a minimum of 700ms at power-on or anytime V_{PTH} drops below V_{REF} . Also asserted for 175ms minimum when RTH (/MR) is externally pulled low (manual reset).
8	VDD	(Analog Input): Power supply input.

Absolute Maximum Ratings (Note 1)

Supply Voltage (V_{DD})	-0.3V to +7V
Input Voltage (V_{RTH}), (V_{NTH}), (V_{PTH})	-0.3V to +7V
Output Voltage ($V_{/RST}$), ($V_{/NMI}$), ($V_{/POF}$)	-0.3V to +7V
/RST Output Current ($I_{/RST}$)	20mA
Storage Temperature (T_S)	-65°C to +150°C
ESD Rating, Note 3	2kV

Operating Ratings (Note 2)

Supply Voltage (V_{DD})	+1.5V to +5.5V
Input Voltage (V_{RTH}), (V_{NTH}), (V_{PTH})	-0.3V to +6V
Output Voltage ($V_{/RST}$), ($V_{/NMI}$), ($V_{/POF}$)	-0.3V to +6V
Ambient Temperature Range (T_A)	-40°C to +85°C
Package Thermal Resistance	
1-layer PCB (θ_{JA})	206°C/W
4-layer PCB (θ_{JA})	113°C/W

Electrical Characteristics

$V_{DD} = 3.3V$; $T_A = 25^\circ C$, **bold** values indicate $-40^\circ C \leq T_A \leq +85^\circ C$; unless noted

Symbol	Parameter	Condition	Min	Typ	Max	Units
I_{DD}	Operating Supply Current	outputs open, V_{RTH} , V_{NTH} , $V_{PTH} > 1.24V$		2.0	4.0	μA
		outputs open, V_{RTH} , V_{NTH} , $V_{PTH} < 1.24V$		1.7		μA
$I_{RTH(MR)}$, I_{NTH} , I_{PTH} , $I_{/RST}$, $I_{/NMI}$, $I_{/POF}$	Leakage Current			5	10	pA nA
V_{REF1}	Threshold Voltage	for RTH(/MR) and PTH inputs	1.215	1.240	1.265	V
V_{REF2}	Threshold Voltage	for NTH inputs	1.215	1.240	1.265	V
V_{HYST}	Hysteresis Voltage on NTH Comparator			20		mV

Reset Output (/RST)

$t_{/RST}$	Reset Pulse Width		700		1200	ms
$t_{/MR}$	Manual Reset Pulse Width		175		300	ms
$V_{/RST}$	/RST Output Voltage Low, Note 4	/RST asserted, $I_{SINK} = 1.6mA$, $V_{DD} \geq 1.6V$			0.3	V
		/RST asserted, $I_{SINK} = 100\mu A$, $V_{DD} \geq 1.2V$			0.4	V

Reset Input [RTH(/MR)]

$V_{/MRTV}$	Manual Reset Trip Voltage		275	310	345	mV
t_{DBNC}	Debounce Time	$V_{/MRTV(min)} < V_{RTH} < V_{/MRTV(max)}$, Note 5	22		38	ms
t_{PROP}	Propagation Delay	from ($V_{/MR} < V_{RTH(/MR)(min)} - 100mV$) to RST Asserted		9		μs

Nonmaskable Interrupt Output (/NMI)

t_{PROP}	Propagation Delay	$(V_{REF(max)} + 100mV) < V_{NTH} < (V_{REF(min)} - 100mV)$		9		μs
$V_{/NMI}$	/NMI Output Voltage Low	/NMI asserted, $I_{SINK} = 1.6mA$, $V_{DD} \geq 1.6V$			0.3	V
		/NMI asserted, $I_{SINK} = 100\mu A$, $V_{DD} \geq 1.2V$			0.4	V

Power-Off Output (/POF)

t_{PROP}	Propagation Delay	$(V_{REF(max)} + 100mV) < V_{PTH} < (V_{REF(min)} - 100mV)$		9		μs
$V_{/POF}$	/POF Output Voltage Low	/POF asserted, $I_{SINK} = 1.6mA$, $V_{DD} \geq 1.6V$			0.3	V
		/POF asserted, $I_{SINK} = 100\mu A$, $V_{DD} \geq 1.2V$			0.4	V

Note 1. Exceeding the absolute maximum rating may damage the device.

Note 2. The device is not guaranteed to function outside its operating rating.

Note 3. Devices are ESD sensitive. Handling precautions recommended. Human body model, 100pF in series with 1.5k .

Note 4. V_{DD} operating range is 1.5V to 5.5V. Output is guaranteed to be held low down to $V_{DD} = 1.2V$.

Note 5. $t_{DBNC} = \frac{t_{/RST}}{32} = \frac{t_{/MR}}{8}$. These relationships are guaranteed by design.

Timing Diagram

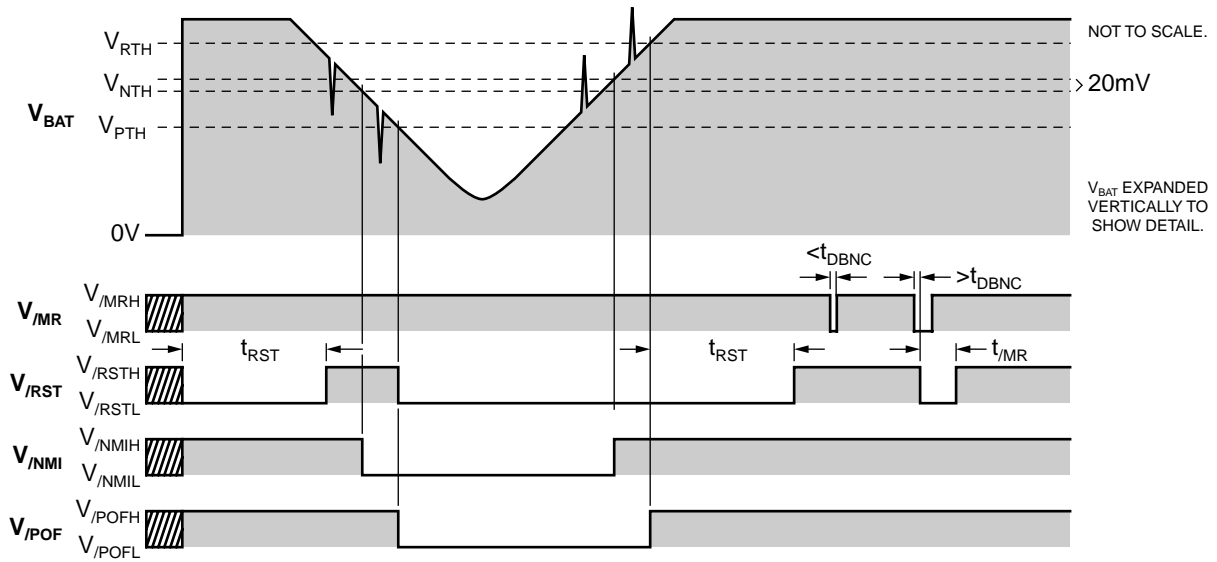

Propagation delays not shown for clarity.
 The MIC2755 ignores very brief transients. See "Application Information" for details.

Block Diagram

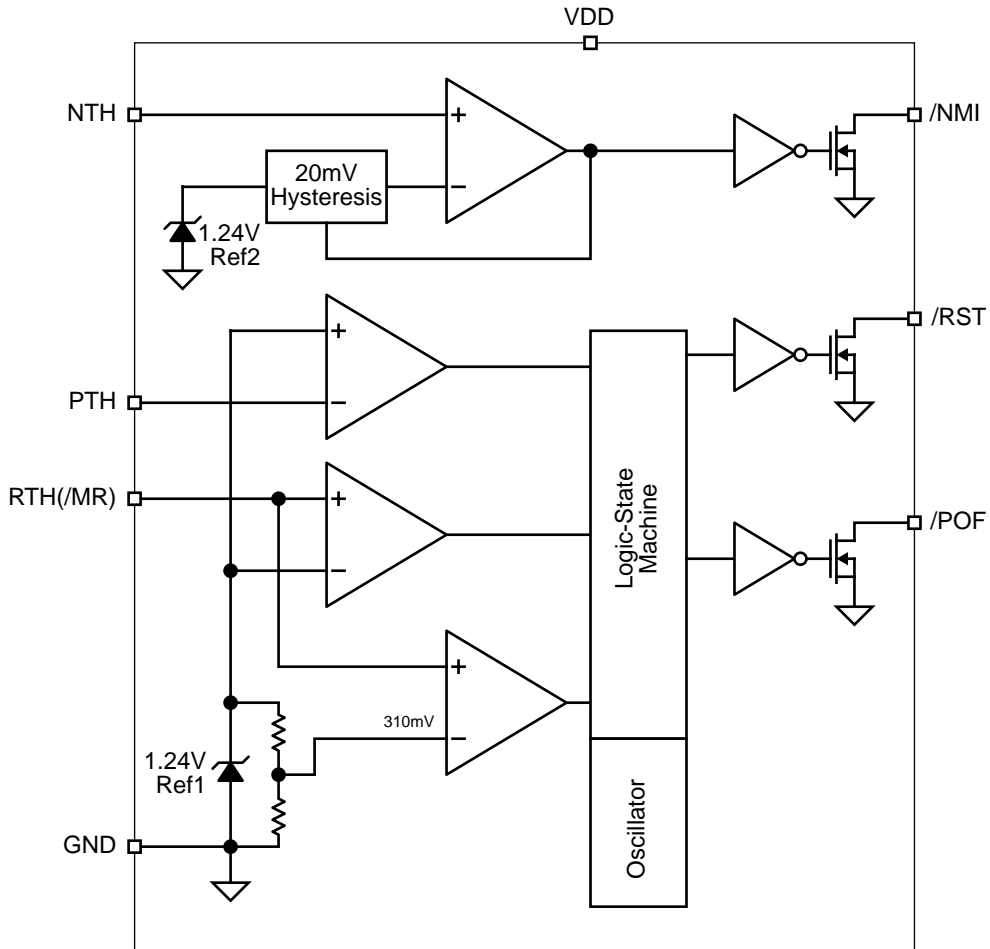

Functional Description

Typically the MIC2755 is used to monitor the battery supply of intelligent circuits such as microcontrollers and microprocessors. By connecting the reset output of a MIC2755 to the reset input of a μC or μP , the processor will be properly reset at power-on and during power-down and low battery conditions. The /NMI output provides low-battery warnings to the system. In addition, a system whose battery voltage declines below the PTH threshold is held in reset to prevent spurious operation. Thus the MIC2755 effectively detects three battery states: "battery OK," "low battery," and "dead battery."

Reset Output

/RST is an active-low, open-drain digital output. This output is asserted for a minimum of 700ms at power-on and for a minimum of 175ms when RTH(/MR) is externally pulled low, indicating that a manual reset should be initiated. /RST is an active-low, open-drain digital output and may be wire-ORed with other open-drain logic signals. Most applications will require a pull-up resistor on this pin. /RST may be pulled up to any voltage not exceeding $V_{/RST(\text{max})}$ even if this voltage is higher than V_{DD} (see "Electrical Characteristics").

Nonmaskable Interrupt Output

/NMI is the output of a comparator that constantly compares the level on the NTH pin with the internal voltage reference, $V_{\text{REF}2}$. This output is asserted when $V_{\text{NTH}} < V_{\text{REF}2}$, indicating high-power system operation should not occur; that is, the battery is low but not dead. Effectively, this function is an uncommitted comparator with its inverting input connected to the internal reference, $V_{\text{REF}2}$, its noninverting input connected to NTH, and its output on /NMI. This comparator does not affect any other MIC2755 functions and may be used independently.

/NMI is an active-low, open-drain digital output and may be wire-ORed with other open-drain logic signals. Most applications will require a pull-up resistor on this pin. /NMI may be pulled up to any voltage not exceeding $V_{/NMI(\text{max})}$ even if this voltage is higher than V_{DD} (see "Electrical Characteristics").

Power-Off Output

This output and the /RST output are asserted and latched when $V_{\text{PTH}} < V_{\text{REF}}$, indicating a "dead battery." The system is held in reset until the battery is replaced or recharged and a power-on reset cycle occurs; that is, $V_{\text{RTH}} > V_{\text{REF}1}$. The /POF output may be used to control a linear or switching regulator, shutting down the regulator when the battery reaches its end-of-life voltage.

/POF is an active-low, open-drain digital output and may be wire-ORed with other open-drain logic signals. Most applications will require a pull-up resistor on this output. /POF may be pulled up to any voltage not exceeding $V_{/POF(\text{max})}$ even if this voltage is higher than V_{DD} (see "Electrical Characteristics").

Power-On Reset

The RTH(/MR) and PTH inputs work together to provide predictable battery monitoring with user-programmable hysteresis and without chatter. The /RST output is asserted for a minimum of 700ms at power-on. Power-on is determined by RTH(/MR) exceeding $V_{\text{REF}1}$. Once this event has occurred, the internal logic ignores further transitions on the RTH(/MR) input, instead monitoring for a low voltage on PTH or the manual reset condition. If V_{PTH} drops below $V_{\text{REF}1}$, the /POF and /RST outputs are asserted and latched, holding the system in its reset state.

Manual Reset

An internal circuit monitors RTH(/MR), comparing it to an internal 310mV reference, $V_{/MRTV}$. When RTH(/MR) is pulled below $V_{/MRTV}$, and V_{PTH} is still above $V_{\text{REF}1}$, the internal circuitry initiates a manual reset cycle and asserts /RST for at least 175ms. A momentary push-button switch is typically connected such that RTH(/MR) is forced to ground when the switch contacts close. This switch is internally debounced. Each closure of the switch longer than t_{DBNC} results in a single output pulse of no less than 175ms and no more than 300ms being generated. (The manual reset pulse is derived from the same oscillator and counter as $t_{/RST}$. The length of $t_{/MR}$ is always equal to one fourth of $t_{/RST}$.) This prevents a user who may hold the switch closed from keeping the system in reset for an extended period of time.

Applications Information

Outputs

Since the MIC2755 outputs are open-drain MOSFETs, most applications will require pull-up resistors. The value of the resistors should not be too large or leakage effects may dominate.

Programming Thresholds

There are separate resistive-divider configurations for circuits that require or do not require manual reset capability.

Configuration Without Manual Reset

See Figure 1. The battery-OK threshold is calculated using:

$$V_{\text{BAT(OK)}} = V_{\text{REF}} \left(\frac{R1 + R2 + R3 + R4}{R4} \right)$$

The low-battery threshold is calculated using:

$$V_{\text{BAT(low)}} = V_{\text{REF}} \left(\frac{R1 + R2 + R3 + R4}{R3 + R4} \right)$$

The dead-battery threshold is calculated using:

$$V_{\text{BAT(dead)}} = V_{\text{REF}} \left(\frac{R1 + R2 + R3 + R4}{R2 + R3 + R4} \right)$$

where, for all equations:

$$V_{\text{REF}} = 1.24\text{V}$$

In order to provide the additional criteria needed to solve for the resistor values, the resistors can be selected such that they have a given total value, that is, $R1 + R2 + R3 + R4 = R_{\text{total}}$. A value such as $1\text{M}\Omega$ for R_{total} is a reasonable value because it draws minimum battery current per resistor ladder but has no significant effect on system accuracy.

When working with large resistors, a small amount of leakage current can cause voltage offsets that degrade system accuracy. The maximum recommended total resistance from V_{BAT} to ground is $3\text{M}\Omega$.

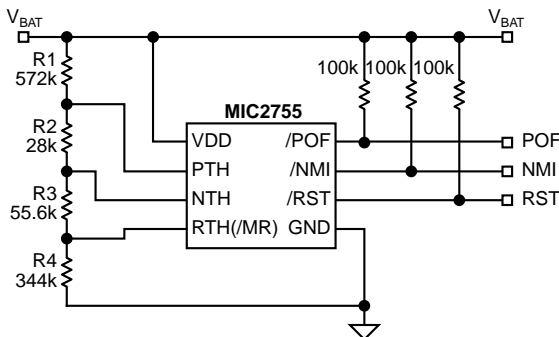

Figure 1. Example Circuit without Manual Reset

Once the desired trip points are determined, set the $V_{\text{BAT(OK)}}$ threshold first.

For a typical single-cell lithium ion battery, 3.6V is a reasonable "OK threshold" because at 3.6V the battery is moderately charged. Solving for R4:

$$V_{\text{BAT(OK)}} = 3.6\text{V} = 1.24\text{V} \left(\frac{1\text{M}\Omega}{R4} \right)$$

$$R4 = 344\text{k}\Omega$$

To determine the resistor values for $V_{\text{BAT(low)}}$ threshold, set $R4 = 344\text{k}\Omega$ and solve for R3.

$$V_{\text{BAT(low)}} = 3.1\text{V} = 1.24\text{V} \left(\frac{1\text{M}\Omega}{R3 + R4} \right)$$

$$R3 = 56\text{k}$$

Once R3 and R4 are determined, the equation for $V_{\text{BAT(dead)}}$ can be used to determine R2. A single lithium-ion cell should not be discharged below 2.5V. Many applications limit the drain to 2.9V. Using 2.9V for the $V_{\text{BAT(dead)}}$ threshold allows calculating the following resistor values.

$$V_{\text{BAT(dead)}} = 2.9\text{V} = 1.24\text{V} \left(\frac{1\text{M}\Omega}{R2 + 55.6\text{k} + 344\text{k}} \right)$$

$$R2 = 27.4\text{k}$$

$$R1 = 1\text{M}\Omega - R2 - R3 - R4 = 572\text{k}$$

Configuration With Manual Reset

See Figure 2. To use manual reset, the MIC2755 requires a separate resistor ladder for the switch and fresh-battery threshold. The remaining two thresholds are set by the three-resistor ladder.

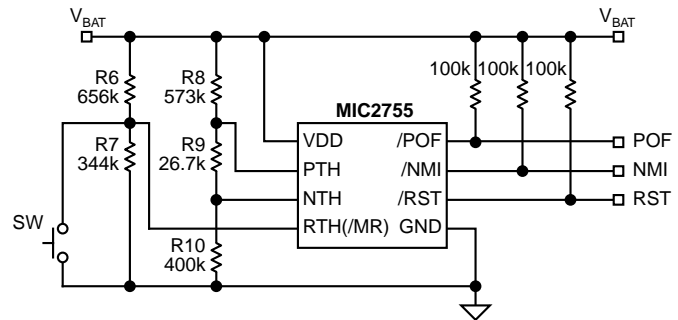

Figure 2. Example Circuit with Manual Reset

$$V_{\text{BAT(OK)}} = V_{\text{REF}} \left(\frac{R6 + R7}{R7} \right)$$

$$V_{\text{BAT(low)}} = V_{\text{REF}} \left(\frac{R8 + R9 + R10}{R10} \right)$$

$$V_{\text{BAT(dead)}} = V_{\text{REF}} \left(\frac{R8 + R9 + R10}{R9 + R10} \right)$$

where, for all equations:

$$V_{\text{REF}} = 1.24\text{V}$$

Once the desired trip points are determined, set $R6 + R7 = 1\text{M}\Omega$ and solve for R7.

$$V_{\text{BAT(fresh)}} = 3.6\text{V} = 1.24\text{V} \left(\frac{1\text{M}\Omega}{R7} \right)$$

$$R7 = 344\text{k}$$

$$R6 = 1\text{M}\Omega - 344\text{k} = 656\text{k}$$

The remaining resistor values are solved in a similar manner as the above.

$$1\text{M}\Omega = R8 + R9 + R10$$

$$V_{\text{BAT}(\text{low})} = 3.1\text{V} = 1.24\text{V} \left(\frac{1\text{M}\Omega}{\text{R10}} \right)$$

$$\text{R10} = 400\text{k}$$

$$1\text{M}\Omega = \text{R10} + \text{R11}$$

$$V_{\text{BAT}(\text{dead})} = 2.9\text{V} = 1.24\text{V} \left(\frac{1\text{M}\Omega}{\text{R9} + 400\text{k}} \right)$$

$$\text{R9} = 27\text{k}$$

$$\text{R8} = 1\text{M}\Omega - \text{R9} - \text{R10} = 573\text{k}$$

The accuracy of the resistors can be chosen based upon the accuracy required by the system.

Input Transients

The MIC2755 is inherently immune to very short negative-going “glitches.” Very brief transients may cross the $V_{\text{BAT}(\text{lo})}$ or $V_{\text{BAT}(\text{dead})}$ thresholds without tripping the output(s).

As shown in Figures 3 and 4, the narrower the transient, the deeper the threshold overdrive that will be ignored by the MIC2755. The graph represents the typical allowable transient duration for a given amount of threshold overdrive that will not cause the corresponding output to change state.

Alternate Configurations

The MIC2755 can be used in a variety of ways. It is especially flexible due to the fact that the NMI comparator is completely independent. There are other useful configuration besides a three-state battery monitor. The NMI comparator can be used to provide power-fail indication (PFI/PFI), monitor an auxiliary battery (LBI/LBO), or detect the presence of an ac adapter.

Voltage Supervisor and Backup Battery Monitor

Figure 5 illustrates the MIC2755 being used as a voltage supervisor and a battery monitor in a 3.3V system with a Lithium coin-cell backup. The primary voltage monitor is configured as a voltage supervisor with a nominal trip point of 3.034V and 33mV of hysteresis as set by R1, R2, and R3. The NMI comparator is used to detect a low-battery condition so the system is aware that the backup battery is discharged. In this example, the /NMI output will be asserted if battery voltage falls below 2.2V. Manual reset capability can be added as discussed in the *Manual Reset* and *Configuration With Manual Reset* sections.

This same configuration can be used to detect the presence of an auxiliary power source such as an ac adapter instead of monitoring a battery. R4 and R5 would be selected such that the /NMI output is deasserted when the proper input voltage is applied.

Voltage Supervisor with Power Fail Warning

Figure 6 illustrates the MIC2755 being used as a voltage supervisor and a power-fail detector in a 3.3V system. The primary voltage monitor is configured as a voltage supervisor

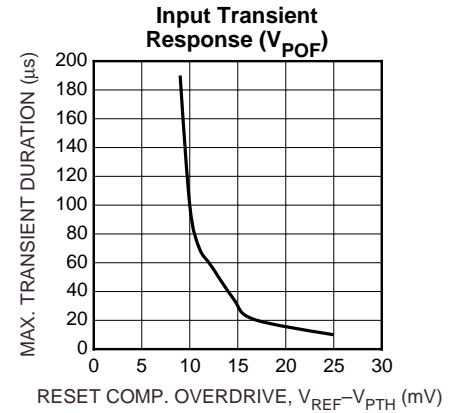

Figure 3. Input Transient Response

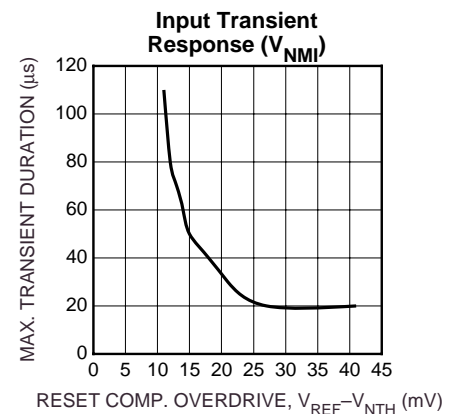

Figure 4. Input Transient Response

with a nominal trip point of 3.034V and 33mV of hysteresis as set by R1, R2, and R3. The NMI comparator is used to detect an impending power failure such as a low-battery condition or ac power outage. The /NMI output will be asserted if the input voltage to the LDO regulator falls below 3.55V. (The MIC5245 has a specified maximum dropout of 250mV at 150mA output current. If the input voltage falls below 3.55V, the output may droop.)

By monitoring the input of the LDO regulator, the system receives the earliest warning of an impending power loss. Manual reset capability can be added as discussed in the *Manual Reset* and *Configuration With Manual Reset* sections.

Supervised Boost Converter and Microcontroller or Microprocessor

In Figures 7 and 8, the MIC2755 is used to monitor the battery and the MIC3172 is used to maintain the output voltage at 3.3V by boosting the input voltage. When the Li-ion battery voltage drops to 3.1V, the MIC2755 alerts the microcontroller or the microprocessor. When the battery voltage drops to 2.9V, the MIC2755 turns off the MIC3172.

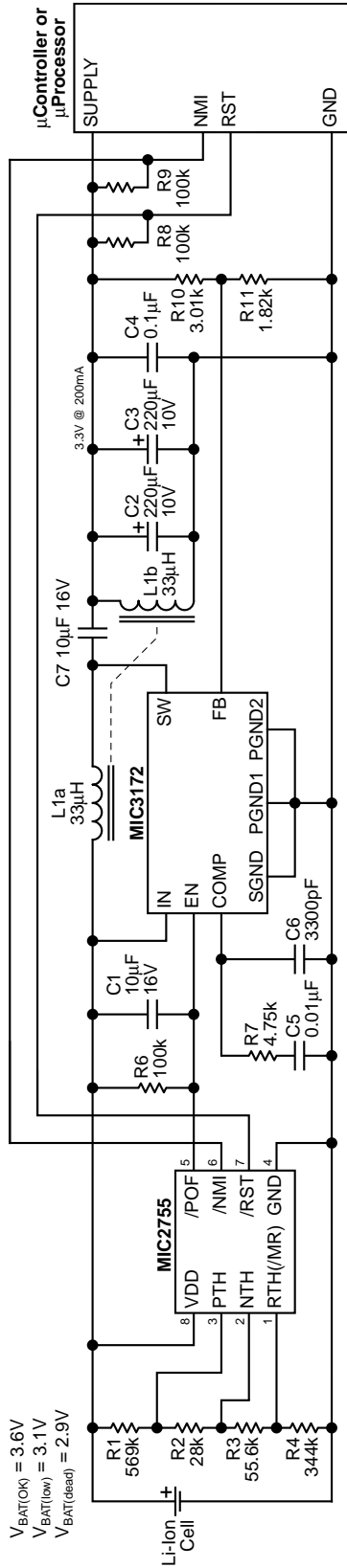

Figure 7. Typical Application Without Manual Reset

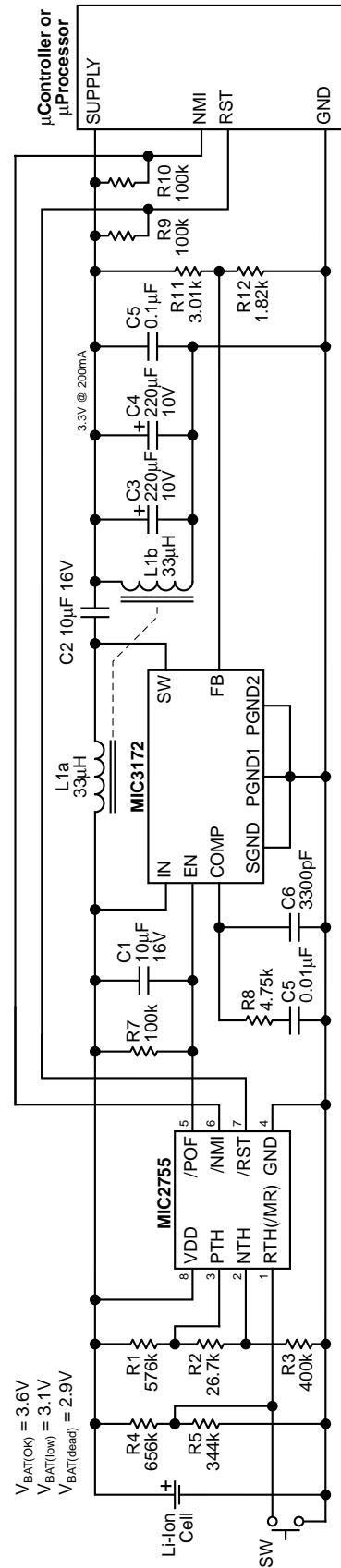
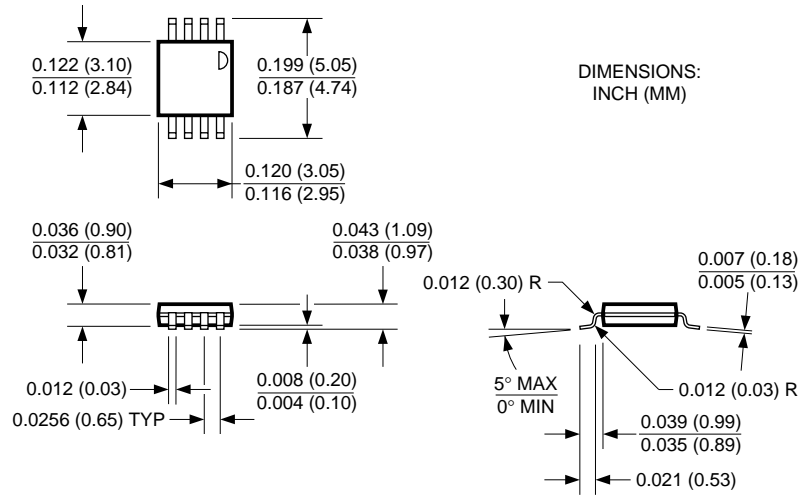

Figure 8. Typical Application With Manual Reset

Package Information



DIMENSIONS:
INCH (MM)

8-Lead MSOP (MM)

MICREL INC. 1849 FORTUNE DRIVE SAN JOSE, CA 95131 USA

TEL + 1 (408) 944-0800 FAX + 1 (408) 944-0970 WEB <http://www.micrel.com>

This information is believed to be accurate and reliable, however no responsibility is assumed by Micrel for its use nor for any infringement of patents or other rights of third parties resulting from its use. No license is granted by implication or otherwise under any patent or patent right of Micrel Inc.

© 2000 Micrel Incorporated