



# 50 Hz to 2.7 GHz 60 dB TruPwr™ Detector

## AD8362

### FEATURES

- Complete fully calibrated measurement/control system
- Accurate rms-to-dc conversion from 50 Hz to 2.7 GHz
- Input dynamic range of >60 dB: -52 dBm to +8 dBm in 50 Ω
- Waveform and modulation independent:  
(Such as GSM/CDMA/TDMA)
- Linear-in-decibels output, scaled 50 mV/dB
- Law conformance error of 0.5 dB
- All functions temperature and supply stable
- Operates from 4.5 V to 5.5 V at 24 mA from -40°C to +85°C
- Power-down capability to 1.3 mW

### APPLICATIONS

- Power amplifier linearization/control loops
- Transmitter power control
- Transmitter signal strength indication (TSSI)
- RF instrumentation

### GENERAL DESCRIPTION

The AD8362 is a true rms-responding power detector that has a 60 dB measurement range. It is intended for use in a variety of high frequency communication systems and in instrumentation requiring an accurate response to signal power. It is easy to use, requiring only a single supply of 5 V and a few capacitors. It can operate from arbitrarily low frequencies to over 2.7 GHz and can accept inputs that have rms values from 1 mV to at least 1 V rms, with peak crest factors of up to 6, exceeding the requirements for accurate measurement of CDMA signals.

The input signal is applied to a resistive ladder attenuator that comprises the input stage of a variable gain amplifier. The 12 tap points are smoothly interpolated using a proprietary technique to provide a continuously variable attenuator, which is controlled by a voltage applied to the VSET pin. The resulting signal is applied to a high performance broadband amplifier. Its output is measured by an accurate square-law detector cell. The fluctuating output is then filtered and compared with the output of an identical squarer, whose input is a fixed dc voltage applied to the VTGT pin, usually the accurate reference of 1.25 V provided at the VREF pin.

The difference in the outputs of these squaring cells is integrated in a high gain error amplifier, generating a voltage at the VOUT pin with rail-to-rail capabilities. In a controller mode, this low noise output can be used to vary the gain of a host system's RF amplifier, thus balancing the set point against

### FUNCTIONAL BLOCK DIAGRAM

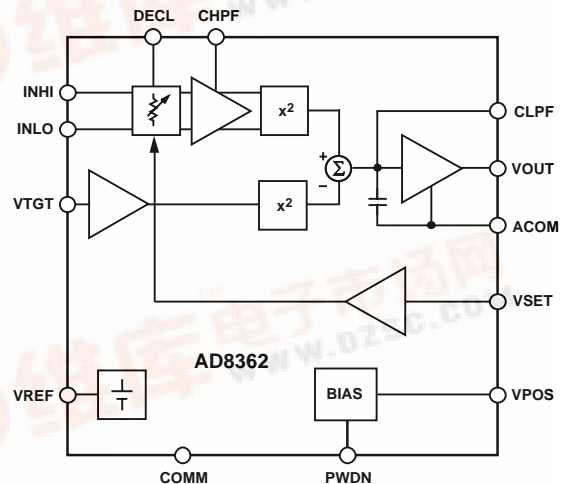

Figure 1.

the input power. Optionally, the voltage at VSET may be a replica of the RF signal's amplitude modulation, in which case the overall effect is to remove the modulation component prior to detection and low-pass filtering. The corner frequency of the averaging filter may be lowered without limit by adding an external capacitor at the CLPF pin. The AD8362 can be used to determine the true power of a high frequency signal having a complex low frequency modulation envelope (or simply as a low frequency rms voltmeter). The high-pass corner generated by its offset-nulling loop can be lowered by a capacitor added on the CHPF pin.

Used as a power measurement device, VOUT is strapped to VSET, and the output is then proportional to the logarithm of the rms value of the input; that is, the reading is presented directly in decibels and is conveniently scaled 1 V per decade, that is, 50 mV/dB; other slopes are easily arranged. In controller modes, the voltage applied to VSET determines the power level required at the input to null the deviation from the setpoint. The output buffer can provide high load currents.

The AD8362 is powered down by a logic high applied to the PWDN pin, i.e., the consumption is reduced to about 1.3 mW. It powers up within about 20 μs to its nominal operating current of 20 mA at 25°C. The AD8362 is supplied in a 16-lead TSSOP package for operation over the industrial temperature range of -40°C to +85°C. An evaluation board is available.

## TABLE OF CONTENTS

Specifications .....	3	Uncertainties in $R_{IN}$ and Power Calibration.....	24
Absolute Maximum Ratings .....	6	Choosing the Right Value for CHPF and CLPF .....	24
ESD Caution.....	6	Use of Nonstandard Target Voltages.....	24
Pin Configuration and Function Description .....	7	Adjusting the Intercept.....	25
Equivalent Circuits.....	8	Altering the Slope.....	25
Typical Performance Characteristics.....	9	Envelope Elimination Mode .....	26
Characterization Setup .....	14	Operator in Controller Modes .....	27
Equipment .....	14	Use of an Input Balun .....	27
Analysis.....	14	General Applications .....	29
Circuit Description.....	15	RMS Voltmeter with >100 dB Dynamic Range.....	29
Square-Law Detection .....	15	RF Power Meter with 80 dB Range.....	30
Effect of Input Coupling on the Intercept Value .....	16	High Slope Detectors Centered on a Narrow Window.....	31
Offset Elimination .....	16	AD8362 Evaluation Board .....	32
Voltage vs. Power Calibration .....	17	Outline Dimensions.....	34
Effect of Signal Waveform.....	17	Ordering Guide .....	34
Operation at Low Frequencies.....	17	<b>REVISION HISTORY</b>	
Time-Domain Response of the Closed Loop .....	17	<b>3/04—Data Sheet Changed from Rev. A to Rev. B.</b>	
Alteration of the Internal Target Voltage.....	18	Updated Format.....	Universal
Effects at Each End of Dynamic Range .....	18	Changes to Specifications.....	3
Input Protection.....	19	Changes to the Offset Elimination Section.....	16
Power-Enable Response Time .....	19	Changes to the Operation at Low Frequencies Section.....	17
Using the AD8362.....	20	Changes to the Time-Domain Response of the Closed Loop Section.....	17
Basic Connections .....	20	Changes to Equation 13.....	24
Main Modes of Operation.....	21	Changes to Table 5.....	31
Operation in Measurement Modes.....	22	<b>6/03—Data Sheet Changed from Rev. 0 to Rev. A.</b>	
Law Conformance Error.....	22	Updated Ordering Guide.....	5
Alternative Input Coupling Means .....	23	Change to Analysis Section .....	12
Using a Narrow-Band Input Match .....	23	Updated AD8362 Evaluation Board Section .....	26
		<b>2/03—Revision 0: Initial Version</b>	



## SPECIFICATIONS

$V_S = 5\text{ V}$ ,  $T = 25^\circ\text{C}$ ,  $Z_O = 50\ \Omega$ , differential input drive via Balun<sup>1</sup>, VTGT connected to VREF, VOUT tied to VSET, unless otherwise noted.

Table 1.

Parameter	Conditions	Min	Typ	Max	Unit
<b>OVERALL FUNCTION</b>					
Maximum Input Frequency			2.7		GHz
Input Power Range (Differential)	dB Referred to 50 $\Omega$ Impedance Level, $f \leq 2.7\text{ GHz}$ , into 1:4 Balun <sup>1</sup>				
Nominal Low End of Range			-52		dBm
Nominal High End of Range			+8		dBm
Input Voltage Range (Differential)	RMS Voltage at Input Terminals, $f \leq 2.7\text{ GHz}$ , into Input of the Device				
Nominal Low End of Range			1.12		mV rms
Nominal High End of Range			1.12		V rms
Input Power Range (S-Sided)	Single-Ended Drive, CW Input, $f \leq 2.7\text{ GHz}$ , into Input Resistive Network <sup>2</sup>				
Nominal Low End of Range			-40		dBm
Nominal High End of Range			0		dBm
Input Voltage Range (S-Sided)	RMS Voltage at Input Terminals, $f \leq 2.7\text{ GHz}$				
Nominal Low End of Range			2.23		mV rms
Nominal High End of Range			223		V rms
Output Voltage Range	$R_L \geq 200\ \Omega$ to Ground				
Nominal Low End of Range			+100		mV
Nominal High End of Range	In General, $V_S - 0.1\text{ V}$		+4.9		V
Output Scaling (Log Slope)			50		mV/dB
Law Conformance Error	Over Central 60 dB Range, $f \leq 2.7\text{ GHz}$		$\pm 0.5$		dB
<b>RF INPUT INTERFACE</b>					
Input Resistance	Pins INHI, INLO, AC-Coupled Single-Ended Drive, wrt DECL Differential Drive		100		$\Omega$
			200		$\Omega$
<b>OUTPUT INTERFACE</b>					
Available Output Range	Pin VOUT $R_L \geq 200\ \Omega$ to Ground	0.1		4.9	V
Absolute Voltage Range					
Nominal Low End of Range	Measurement Mode, $f = 900\text{ MHz}$ , $P_{IN} = -52\text{ dBm}$	0.32		0.48	V
Nominal High End of Range	Measurement Mode, $f = 900\text{ MHz}$ , $P_{IN} = +8\text{ dBm}$	3.44		3.52	V
Source/Sink Current	VOUT Held at $V_S/2$ , to 1% Change		48		mA
Slew Rate Rising	$C_L = \text{Open}$		60		V/ $\mu\text{s}$
Slew Rate Falling	$C_L = \text{Open}$		5		V/ $\mu\text{s}$
Rise Time, 10% to 90%	0.2 V to 1.8 V, CLPF = 0		45		ns
Fall Time, 90% to 10%	1.8 V to 0.2 V, CLPF = 0		0.4		$\mu\text{s}$
Wideband Noise	CLPF = 1000 pF, $f_{\text{SPOT}} \leq 100\text{ kHz}$		70		nV/ $\sqrt{\text{Hz}}$
<b>VSET INTERFACE</b>					
Nominal Input Voltage Range	Pin VSET To $\pm 1\text{ dB}$ Error	0.5		3.75	V
Input Resistance			68		k $\Omega$
Scaling (Log Slope)	$f = 900\text{ MHz}$	46	50	54	mV/dB
Scaling (Log Intercept)	$f = 900\text{ MHz}$ , into 1:4 Balun	-64	-60	-56	dBm
		-77	-73	-69	dBV
<b>VOLTAGE REFERENCE</b>					
Output Voltage	Pin VREF 25 $^\circ\text{C}$	1.225	1.25	1.275	V
Temperature Sensitivity <sup>3</sup>	-40 $^\circ\text{C} \leq T_A \leq +85^\circ\text{C}$		0.08		mV/ $^\circ\text{C}$
Output Resistance			8		$\Omega$



# AD8362

Parameter	Conditions	Min	Typ	Max	Unit
<b>RMS TARGET INTERFACE</b>					
Nominal Input Voltage Range	Pin VTGT Measurement Range = 60 dB, to $\pm 1$ dB Error	0.625		2.5	V
Input Bias Current	VTGT = 1.25 V		-28		$\mu$ A
	VTGT = 0 V		-52		$\mu$ A
Incremental Input Resistance			52		k $\Omega$
<b>POWER-DOWN INTERFACE</b>					
Logic Level to Enable	Pin PWDN Logic Low Enables			1	V
Logic Level to Disable	Logic High Disables	3			V
Input Current	Logic High		230		$\mu$ A
	Logic Low		5		$\mu$ A
Enable Time	From PWDN Low to VOUT within 10% of Final Value, CLPF = 1000 pF		14.5		ns
Disable Time	From PWDN High to VOUT within 10% of Final Value, CLPF = 1000 pF		2.5		$\mu$ s
<b>POWER SUPPLY INTERFACE</b>					
Supply Voltage	Pin VPOS	4.5	5	5.5	V
Quiescent Current			20	22	mA
Supply Current	When Disabled		0.2		mA
<b>900 MHz</b>					
Dynamic Range	Error Referred to Best Fit Line (Linear Regression)				
	$\pm 1$ dB Linearity, CW Input		65		dB
	$\pm 0.5$ dB Linearity, CW Input		62		dB
Deviation vs. Temperature	Deviation from Output at 25°C				
	-40°C < T <sub>A</sub> < +85°C; P <sub>IN</sub> = -45 dBm		-1.7		dB
	-40°C < T <sub>A</sub> < +85°C; P <sub>IN</sub> = -20 dBm		-1.4		dB
	-40°C < T <sub>A</sub> < +85°C; P <sub>IN</sub> = +5 dBm		-1		dB
Logarithmic Slope		46	50	54	mV/dB
Logarithmic Intercept		-64	-60	-56	dBm
Deviation from CW Response	5.5 dB Peak-to-RMS Ratio (IS95 Reverse Link)		0.2		dB
	12 dB Peak-to-RMS Ratio (WCDMA 4 Channels)		0.2		dB
	18 dB Peak-to-RMS Ratio (WCDMA 15 Channels)		0.5		dB
<b>1.9 GHz</b>					
Dynamic Range	Error Referred to Best Fit Line (Linear Regression)				
	$\pm 1$ dB Linearity, CW Input		65		dB
	$\pm 0.5$ dB Linearity, CW Input		62		dB
Deviation vs. Temperature	Deviation from Output at 25°C				
	-40°C < T <sub>A</sub> < +85°C; P <sub>IN</sub> = -45 dBm		-0.6		dB
	-40°C < T <sub>A</sub> < +85°C; P <sub>IN</sub> = -20 dBm		-0.5		dB
	-40°C < T <sub>A</sub> < +85°C; P <sub>IN</sub> = +5 dBm		-0.3		dB
Logarithmic Slope			51		mV/dB
Logarithmic Intercept			-59		dBm
Deviation from CW Response	5.5 dB Peak-to-RMS Ratio (IS95 Reverse Link)		0.2		dB
	12 dB Peak-to-RMS Ratio (WCDMA 4 Channels)		0.2		dB
	18 dB Peak-to-RMS Ratio (WCDMA 15 Channels)		0.5		dB



Parameter	Conditions	Min	Typ	Max	Unit
2.2 GHz					
Dynamic Range	Error Referred to Best Fit Line (Linear Regression)				
	±1 dB Linearity, CW Input		65		dB
	±0.5 dB Linearity, CW Input		65		dB
Deviation vs. Temperature	Deviation from Output at 25°C				
	−40°C < T <sub>A</sub> < +85°C; P <sub>IN</sub> = −45 dBm		−1.8		dB
	−40°C < T <sub>A</sub> < +85°C; P <sub>IN</sub> = −20 dBm		−1.6		dB
	−40°C < T <sub>A</sub> < +85°C; P <sub>IN</sub> = +5 dBm		−1.3		dB
Logarithmic Slope			50.5		mV/dB
Logarithmic Intercept			−61		dBm
Deviation from CW Response	5.5 dB Peak-to-RMS Ratio (IS95 Reverse Link)		0.2		dB
	12 dB Peak-to-RMS Ratio (WCDMA 4 Channels)		0.2		dB
	18 dB Peak-to-RMS Ratio (WCDMA 15 Channels)		0.5		dB
2.7 GHz					
Dynamic Range	Error Referred to Best Fit Line (Linear Regression)				
	±1 dB Linearity, CW Input		63		dB
	±0.5 dB Linearity, CW Input		62		dB
Deviation vs. Temperature	Deviation from Output at 25°C				
	−40°C < T <sub>A</sub> < +85°C; P <sub>IN</sub> = −40 dBm		−5.3		dB
	−40°C < T <sub>A</sub> < +85°C; P <sub>IN</sub> = −15 dBm		−5.5		dB
	−40°C < T <sub>A</sub> < +85°C; P <sub>IN</sub> = +15 dBm		−4.8		dB
Logarithmic Slope			50.5		mV/dB
Logarithmic Intercept			−58		dBm
Deviation from CW Response	5.5 dB Peak-to-RMS Ratio (IS95 Reverse Link)		0.2		dB
	12 dB Peak-to-RMS Ratio (WCDMA 4 Channels)		0.2		dB
	18 dB Peak-to-RMS Ratio (WCDMA 15 Channels)		0.4		dB

<sup>1</sup> 1:4 balun transformer, M/A-COM ETC 1.6-4-2-3.

<sup>2</sup> Resistive network consists of 33 Ω shunt and 25 Ω series.

<sup>3</sup> See Figure 36.



# AD8362

## ABSOLUTE MAXIMUM RATINGS

Table 2.

Parameters	Ratings
Supply Voltage VPOS	5.5 V
Input Power (into Input of Device)	13 dBm
Equivalent Voltage	2 V rms
Internal Power Dissipation	500 mW
$\theta_{JA}$	125°C/W
Maximum Junction Temperature	125°C/W
Operating Temperature Range	-40°C to +85°C
Storage Temperature Range	-65°C to +150°C
Lead Temperature Range (Soldering 60 sec)	300°C

Stresses above those listed under Absolute Maximum Ratings may cause permanent damage to the device. This is a stress rating only; functional operation of the device at these or any other conditions above those indicated in the operational section of this specification is not implied. Exposure to absolute maximum rating conditions for extended periods may affect device reliability.

### ESD CAUTION

ESD (electrostatic discharge) sensitive device. Electrostatic charges as high as 4000 V readily accumulate on the human body and test equipment and can discharge without detection. Although this product features proprietary ESD protection circuitry, permanent damage may occur on devices subjected to high energy electrostatic discharges. Therefore, proper ESD precautions are recommended to avoid performance degradation or loss of functionality.



## PIN CONFIGURATION AND FUNCTION DESCRIPTION

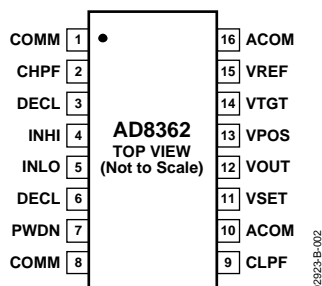

Figure 2. Pin Configuration

Table 3. Pin Function Descriptions

Pin No.	Mnemonic	Description	Equivalent Circuit
1, 8	COMM	Common Connection. Connect via low impedance to system common.	
2	CHPF	Input HPF. Connect to common via a capacitor to determine 3 dB point of input signal high-pass filter.	
3, 6	DECL	Decoupling Terminals for INHI and INLO. Connect to common via a large capacitance to complete input circuit.	
4	INHI	High Signal Input Terminal. Part of a differential input port with INLO.	Circuit A
5	INLO	Low Signal Input Terminal. Part of a differential input port with INHI.	Circuit A
7	PWDN	Disable/Enable Control Input. Apply logic high voltage to shut down the AD8362.	
9	CLPF	Connection for loop filter integration (averaging) capacitor, the other pin of which is usually grounded via a resistor to improve loop stability and response time.	
10, 16	ACOM	Analogue Common Connection for Output Amplifier.	
11	VSET	The voltage applied to this pin sets the decibel value of the required RF input voltage that results in zero current out of CLPF and thus the loop integrating capacitor.	Circuit B
12	VOUT	Output of Error Amplifier. In measurement mode, normally connected directly to VSET.	Circuit C
13	VPOS	Connect to 5 V Power Supply.	
14	VTGT	The logarithmic intercept voltage is proportional to the voltage applied to this pin. The use of a lower target voltage increases the crest factor capacity.	Circuit D
15	VREF	General-Purpose Reference Voltage Output of 1.25 V (usually connected only to VTGT).	Circuit E



EQUIVALENT CIRCUITS

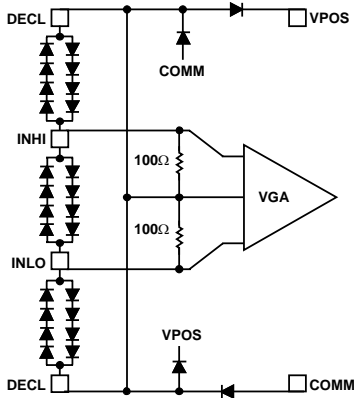

Figure 3. Circuit A

02923-B-003

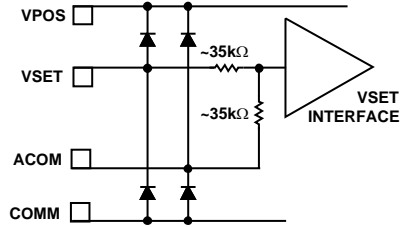

Figure 4. Circuit B

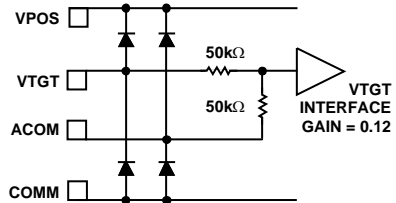

Figure 5. Circuit C

02923-B-004

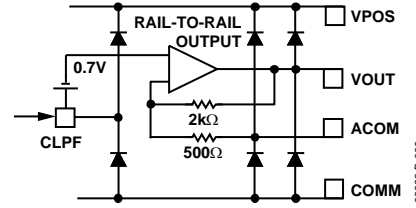

Figure 6. Circuit D

02923-B-006

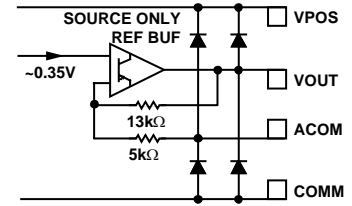

Figure 7. Circuit E

02923-B-007



# TYPICAL PERFORMANCE CHARACTERISTICS

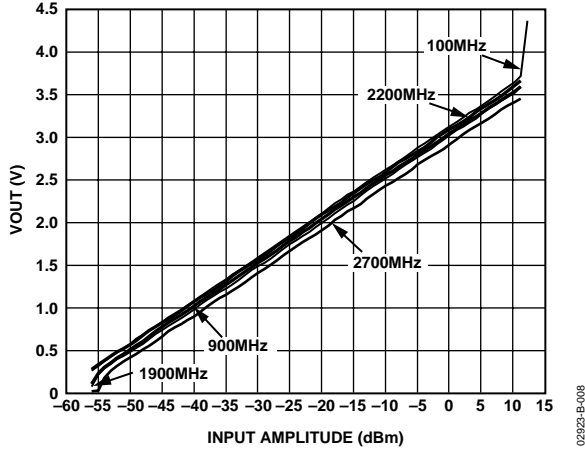

Figure 8. Output Voltage (VOUT) vs. Input Amplitude (dBm), Frequencies 100 MHz, 900 MHz, 1900 MHz, 2200 MHz, 2700 MHz, Sine Wave, Differential Drive

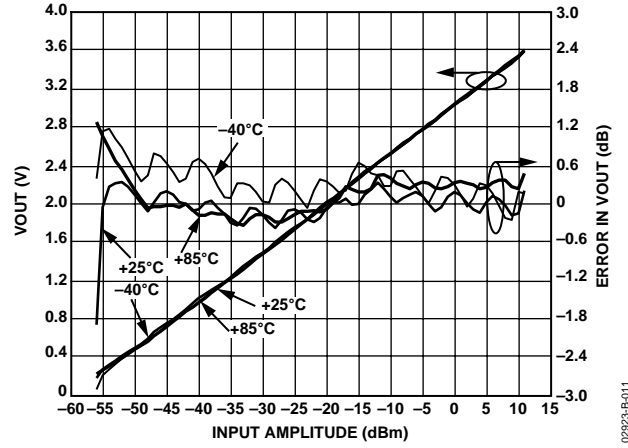

Figure 11. VOUT and Law Conformance vs. Input Amplitude, Frequency 1900 MHz, Sine Wave, Temperature -40°C, +25°C, and +85°C

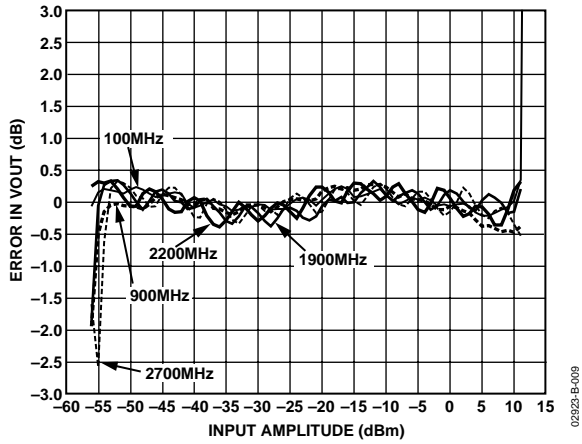

Figure 9. Logarithmic Law Conformance vs. Input Amplitude, Frequencies 100 MHz, 900 MHz, 1900 MHz, 2200 MHz, 2700 MHz, Sine Wave, Differential Drive

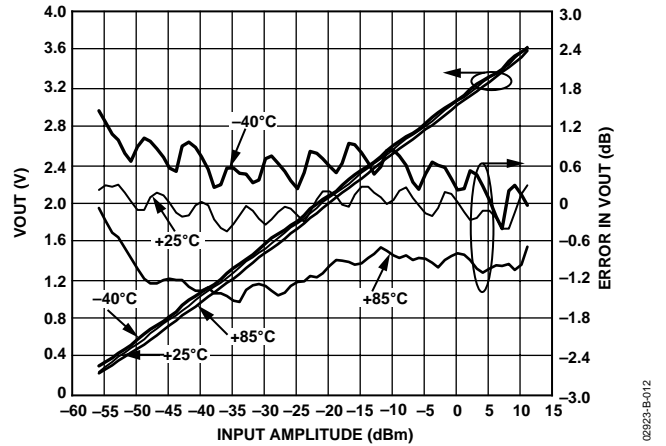

Figure 12. VOUT and Law Conformance vs. Input Amplitude, Frequency 2200 MHz, Sine Wave, Temperature -40°C, +25°C, and +85°C

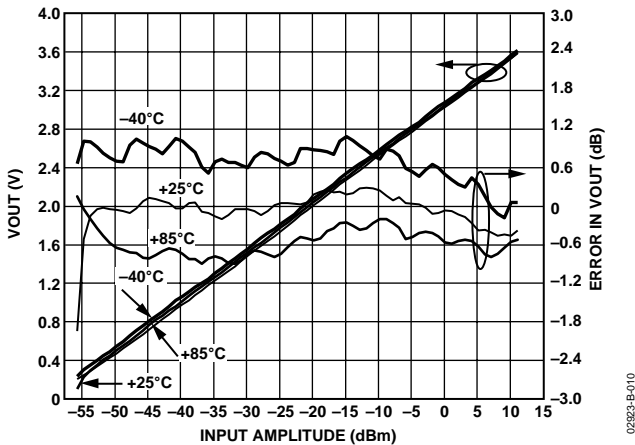

Figure 10. VOUT and Law Conformance vs. Input Amplitude, Frequency 900 MHz, Sine Wave, Temperature -40°C, +25°C, and +85°C

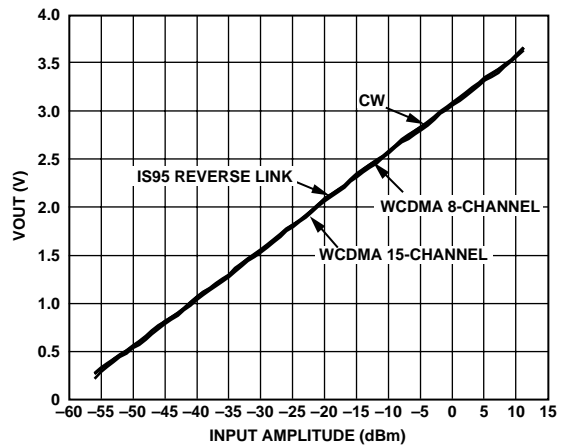

Figure 13. VOUT vs. Input Amplitude with Different Waveforms, CW, IS95 Reverse Link, WCDMA 8-Channel, WCDMA 15-Channel, Frequency 900 MHz



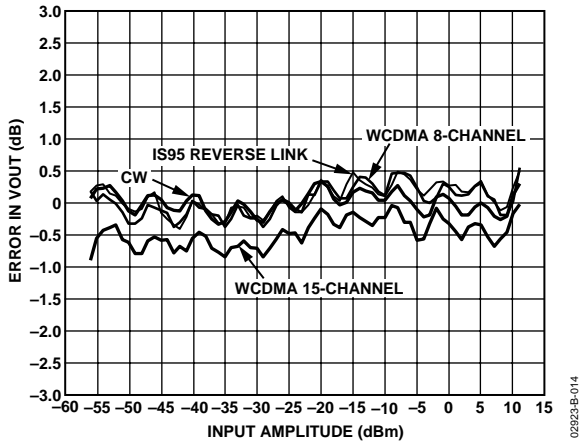

Figure 14. Output Error from CW Linear Reference vs. Input Amplitude with Different Waveforms, CW, IS95 Reverse Link, WCDMA 8-Channel, WCDMA 15-Channel, Frequency 900 MHz



Figure 17. Output Error from CW Linear Reference vs. Input Amplitude, 3 Sigma to Either Side of Mean, with WCDMA 8-Channel, WCDMA 15-Channel, Frequency 1900 MHz

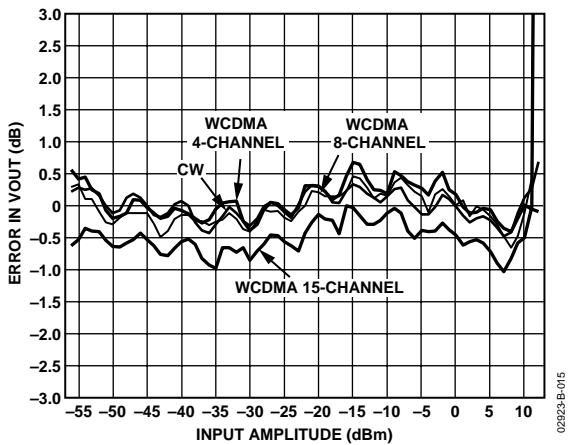

Figure 15. Output Error from CW Linear Reference vs. Input Amplitude with Different WCDMA Channel Loading, 4-Channel, 8-Channel, 15-Channel, Frequency 2200 MHz

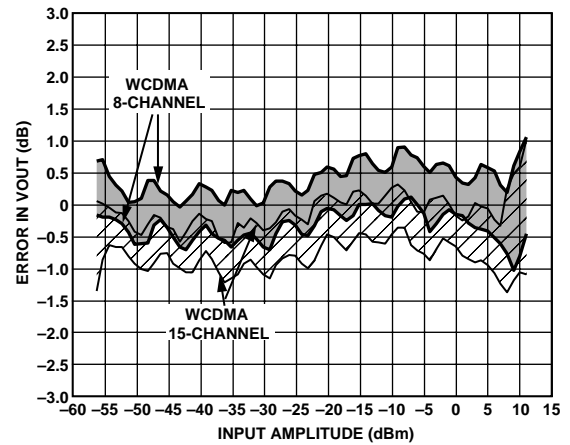

Figure 18. Output Error from CW Linear Reference vs. Input Amplitude, 3 Sigma to Either Side of Mean, with WCDMA 8-Channel, WCDMA 15-Channel, Frequency 2200 MHz

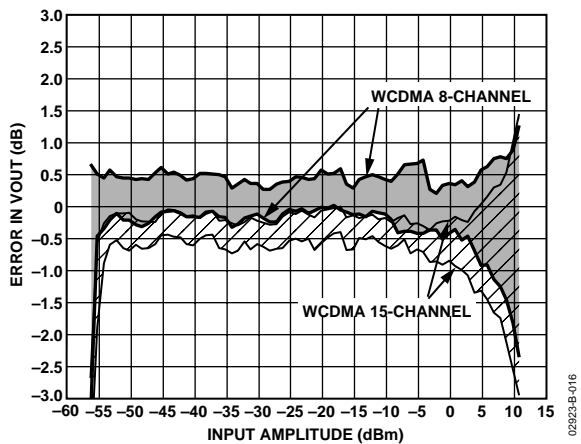

Figure 16. Output Error from CW Linear Reference vs. Input Amplitude, 3 Sigma to Either Side of Mean, with WCDMA 8-Channel, WCDMA 15-Channel, Frequency 1900 MHz

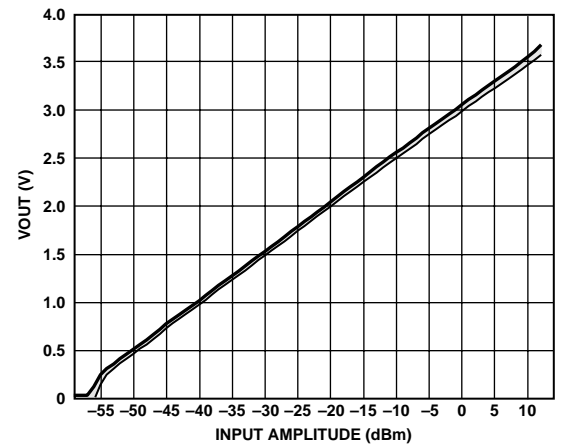

Figure 19. VOUT vs. Input Amplitude, 3 Sigma to Either Side of Mean, Sine Wave, Frequency 900 MHz, Part-to-Part Variation



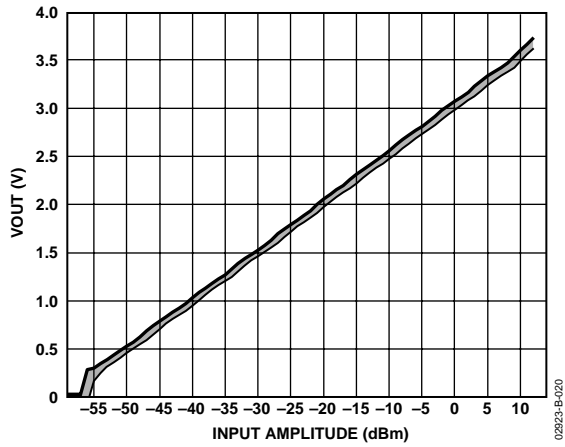

Figure 20. VOUT vs. Input Amplitude, 3 Sigma to Either Side of Mean, Sine Wave, Frequency 1900 MHz, Part-to-Part Variation

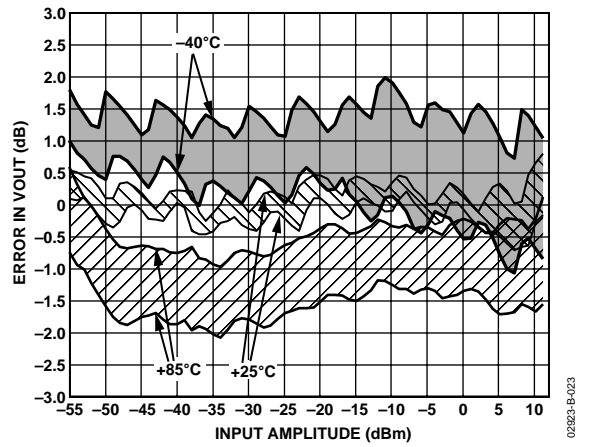

Figure 23. Logarithmic Law Conformance vs. Input Amplitude, 3 Sigma to Either Side of Mean, Sine Wave, Frequency 2200 MHz, Temperature  $-40^{\circ}\text{C}$ ,  $+25^{\circ}\text{C}$ , and  $+85^{\circ}\text{C}$

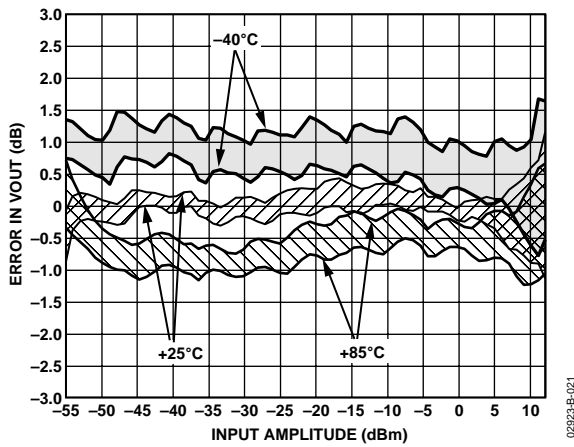

Figure 21. Logarithmic Law Conformance vs. Input Amplitude, 3 Sigma to Either Side of Mean, Sine Wave, Frequency 900 MHz, Temperature  $-40^{\circ}\text{C}$ ,  $+25^{\circ}\text{C}$ , and  $+85^{\circ}\text{C}$

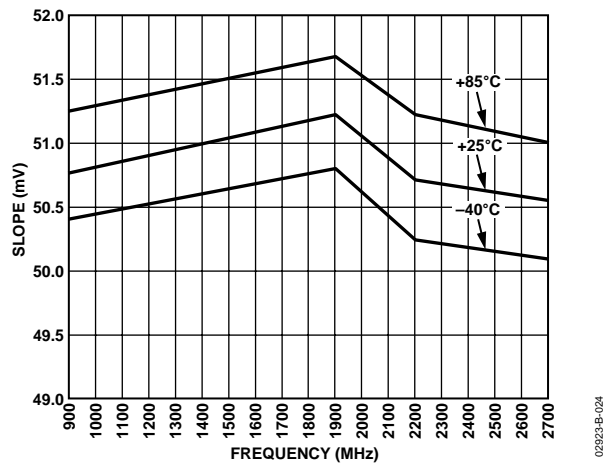

Figure 24. Logarithmic Slope vs. Frequency, Temperature  $-40^{\circ}\text{C}$ ,  $+25^{\circ}\text{C}$ , and  $+85^{\circ}\text{C}$

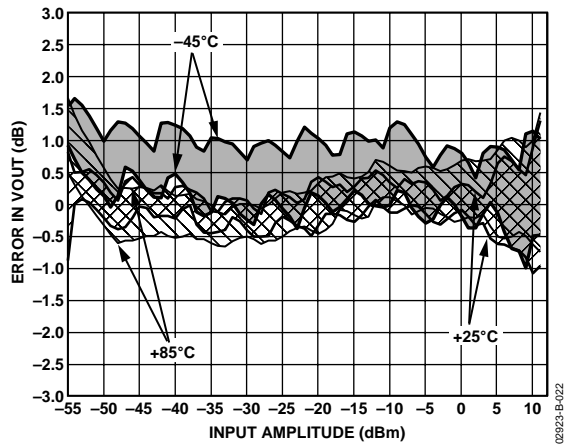

Figure 22. Logarithmic Law Conformance vs. Input Amplitude, 3 Sigma to Either Side of Mean, Sine Wave, Frequency 1900 MHz, Temperature  $-40^{\circ}\text{C}$ ,  $+25^{\circ}\text{C}$ , and  $+85^{\circ}\text{C}$

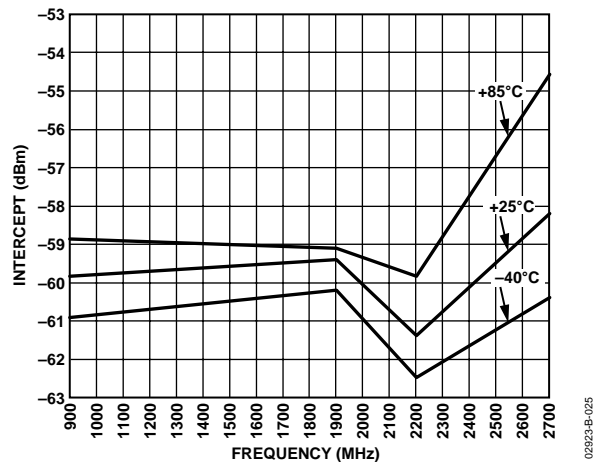
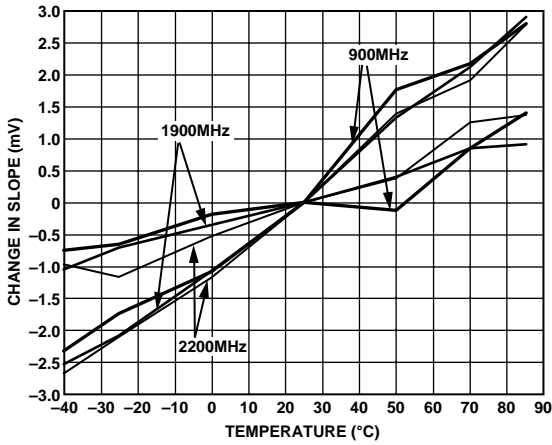

Figure 25. Logarithmic Intercept vs. Frequency, Temperature  $-40^{\circ}\text{C}$ ,  $+25^{\circ}\text{C}$ , and  $+85^{\circ}\text{C}$



# AD8362



02923-B-026

Figure 26. Change in Logarithmic Slope vs. Temperature, 3 Sigma to Either Side of Mean, Frequencies 900 MHz, 1900 MHz, 2200 MHz

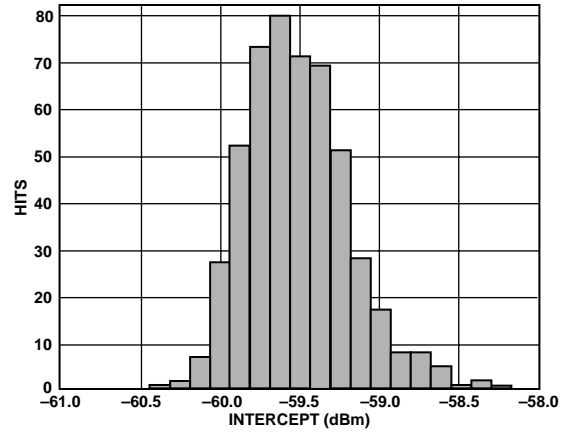

02923-B-029

Figure 29. Logarithmic Intercept Distribution, Frequency 900 MHz

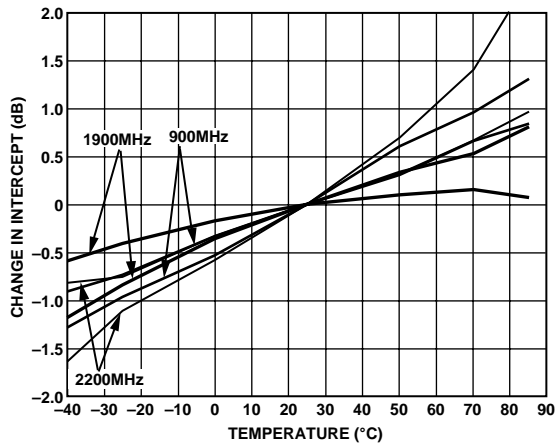

02923-B-027

Figure 27. Change in Logarithmic Intercept vs. Temperature, 3 Sigma to Either Side of Mean, Frequencies 900 MHz, 1900 MHz, 2200 MHz

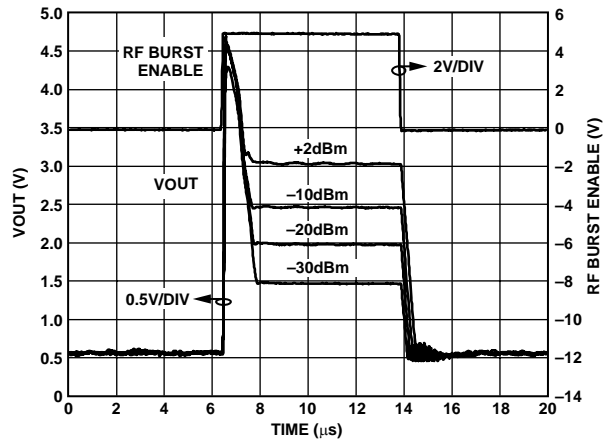

02923-B-030

Figure 30. Output Response to RF Burst Input for Various RF Input Levels, Carrier Frequency 900 MHz, CLPF = 0.1  $\mu$ F

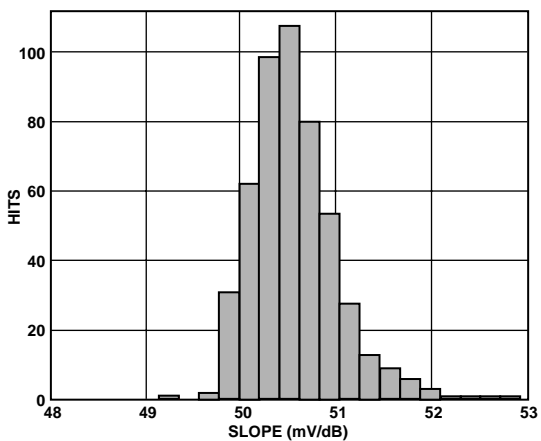

02923-B-028

Figure 28. Slope Distribution, Frequency 900 MHz

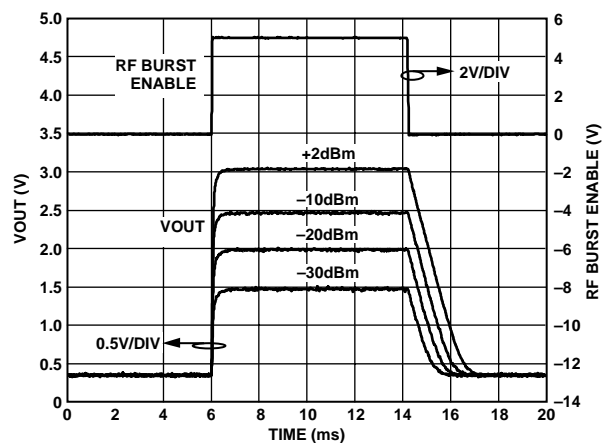

02923-B-031

Figure 31. Output Response to RF Burst Input for Various RF Input Levels, Carrier Frequency 900 MHz, CLPF = 0.1  $\mu$ F



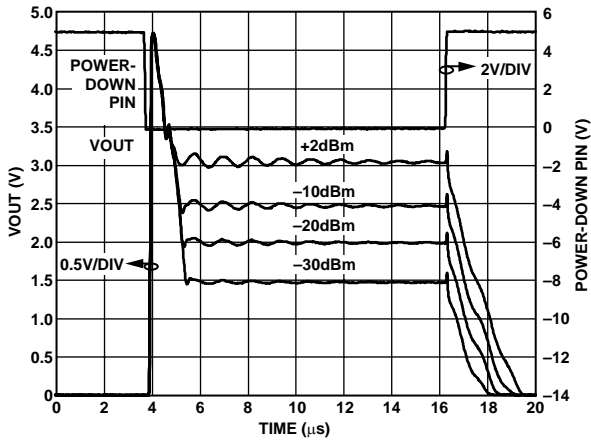

Figure 32. Output Response Using Power-Down Mode for Various RF Input Levels, Carrier Frequency 900 MHz, CLPF = 0

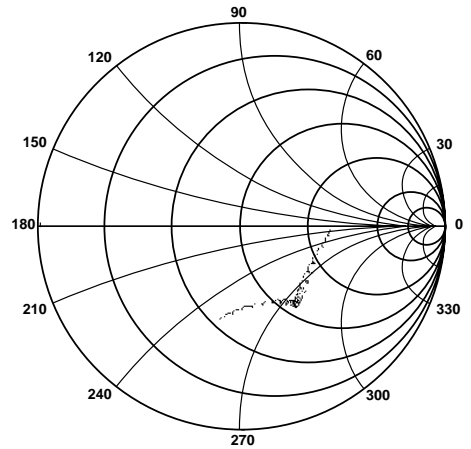

Figure 35. Input Impedance,  $Z_o = 50 \Omega$ , Differential Drive

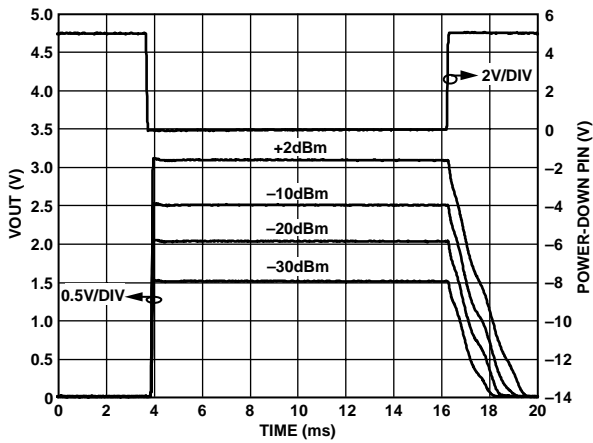

Figure 33. Output Response Using Power-Down Mode for Various RF Input Levels, Carrier Frequency 900 MHz, CLPF = 0.1  $\mu$ F

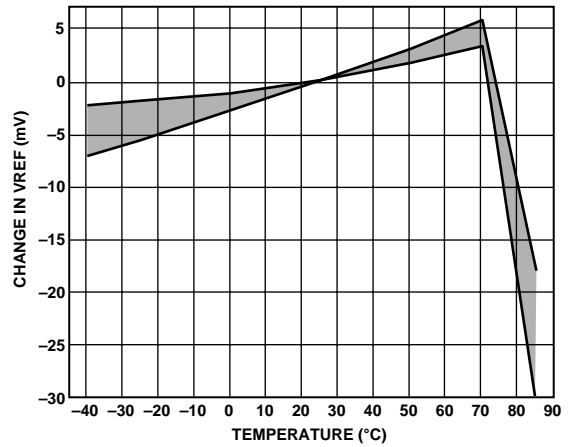

Figure 36. Change in VREF vs. Temperature, 3 Sigma to Either Side of Mean

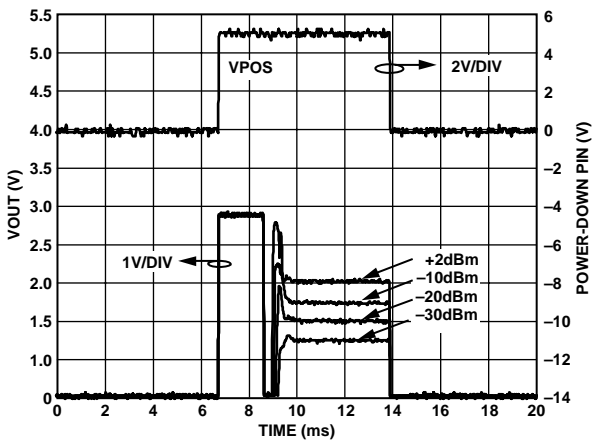

Figure 34. Output Response to Gating on Power Supply for Various RF Input Levels, Carrier Frequency 900 MHz, CLPF = 0

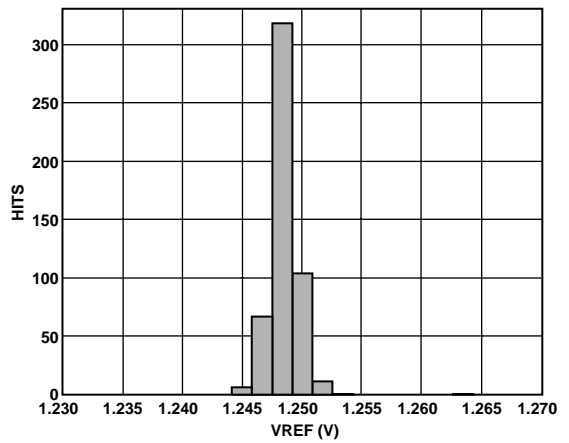

Figure 37. VREF Distribution



# AD8362

## CHARACTERIZATION SETUP

### EQUIPMENT

The general hardware configuration used for most of the AD8362 characterization is shown in Figure 38. The signal source used was a Rohde & Schwarz SMIQ03B. A 1:4 balun transformer was used to transform the single-ended RF signal to differential form. For the response measurements in Figure 30 and Figure 31, the configuration shown in Figure 39 was used; for Figure 32 and Figure 33, the configuration shown in Figure 40 was used; and for Figure 34, the configuration shown in Figure 41 was used.

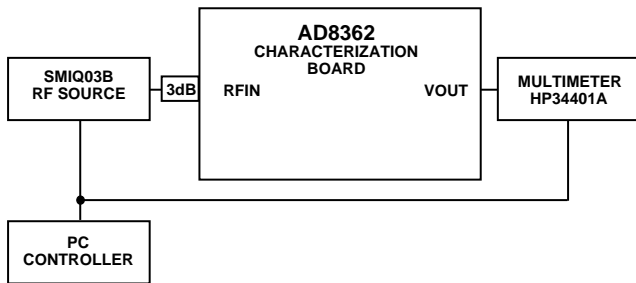

Figure 38. Primary Characterization Setup

### ANALYSIS

The slope and intercept are derived using the coefficients of a linear regression performed on data collected in its central operating range. Error is stated in two forms: error from linear response to CW waveform and output delta from 25°C performance.

The error from linear response to CW waveform is the decibel difference in output from the ideal output defined by the conversion gain and output reference. This is a measure of the linearity of the device response to both CW and modulated waveforms. The error in dB is calculated by

$$\text{Error (dB)} = \frac{V_{OUT} - \text{Slope} \times (P_{IN} - P_Z)}{\text{Slope}}$$

where  $P_Z$  is the x intercept, expressed in dBm.

Error from the linear response to CW waveform is not a measure of absolute accuracy since it is calculated using the slope and intercept of each device. However, it verifies the linearity and the effect of modulation on the device response. Error from 25°C performance uses the performance of a given device and waveform type as the reference; it is predominantly a measurement of output variation with temperature.

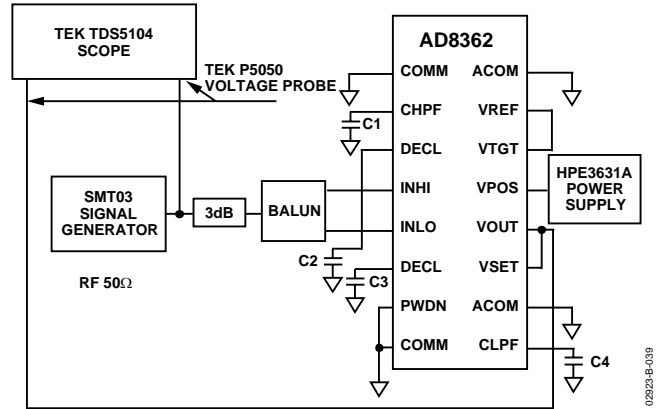

Figure 39. Response Measurement Setup for Modulated Pulse

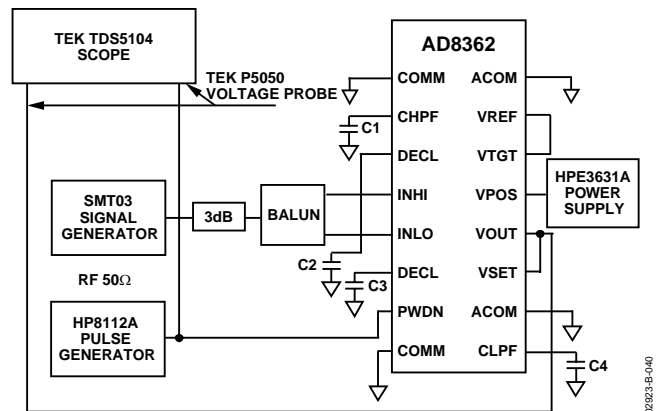

Figure 40. Response Measurement Setup for Power-Down Step

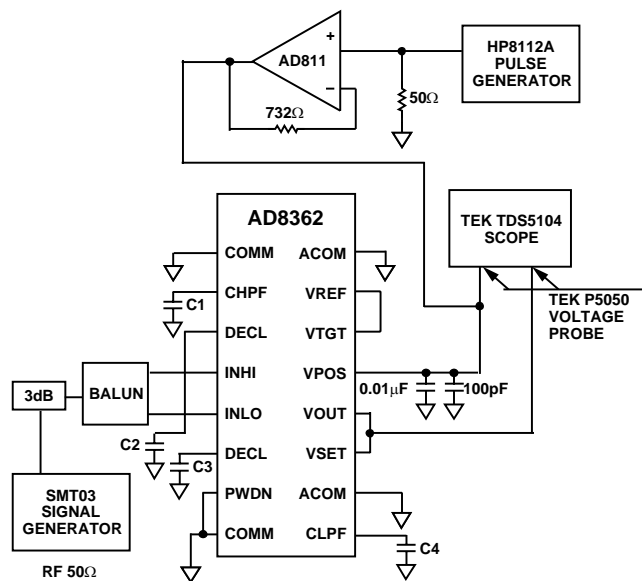

Figure 41. Response Measurement Setup for Gated Supply



## CIRCUIT DESCRIPTION

The AD8362 is a fully calibrated, high accuracy, rms-to-dc converter providing a measurement range of over 60 dB. It is capable of operation from signals as low in frequency as a few Hertz to at least 2.7 GHz. Unlike earlier rms-to-dc converters, the response bandwidth is completely independent of the signal magnitude. The  $-3$  dB point occurs at about 3.5 GHz. The capacity of this part to accurately measure waveforms having a high peak-to-rms ratio (crest factor) is independent of either the signal frequency or its absolute magnitude, over a wide range of conditions.

This unique combination allows the AD8362 be to used with equal ease as a calibrated RF wattmeter covering a power ratio of  $>1,000,000:1$ , as a power controller in closed-loop systems, or as a general-purpose rms-responding voltmeter, and in many other low frequency applications.

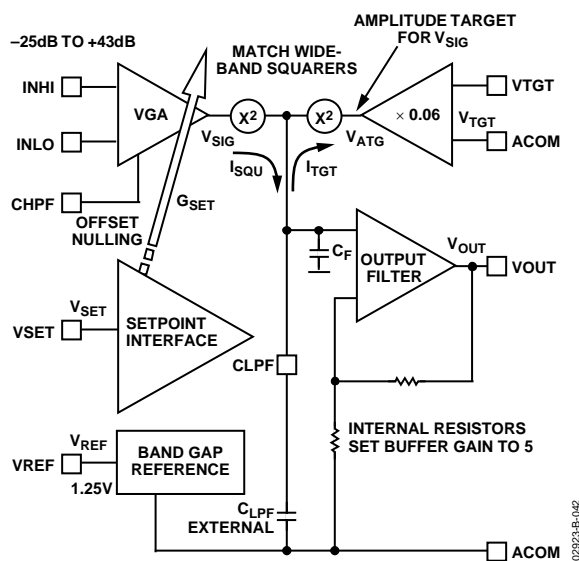

Figure 42. Basic Structure of the AD8362

The part comprises the core elements of a high performance AGC loop (Figure 42), laser-trimmed during manufacture to close tolerances while fully operational at a test frequency of 100 MHz. Its linear, wideband, variable gain amplifier (VGA) provides a general voltage gain,  $G_{SET}$ ; this may be controlled in a precisely exponential (linear-in-dB) manner over the full 68 dB range from  $-25$  dB to  $+43$  dB by a voltage  $V_{SET}$ . However, to provide adequate guard-banding, only the central 60 dB of this range, from  $-21$  dB to  $+39$  dB, is normally used. Later, it is

shown how this basic range may be shifted either up or down, and even extended to  $>80$  dB. The VGA gain has the form

$$G_{SET} = G_O \exp(-V_{SET}/V_{GNS}) \quad (1)$$

where  $G_O$  is a basic fixed gain and  $V_{GNS}$  is a scaling voltage that defines the gain slope (the dB change per volt). Note that the gain decreases with  $V_{SET}$ . The VGA output is

$$V_{SIG} = G_{SET} V_{IN} = G_O V_{IN} \exp(V_{SET}/V_{GNS}) \quad (2)$$

where  $V_{IN}$  is the ac voltage applied to the input terminals of the AD8362.

As is later explained more fully, the input drive may be either single-sided or differential but optimum performance at input drive. The effect of HF imbalances when using a single-sided drive is less apparent at low frequencies (from 50 Hz to 500 MHz), but the peak input voltage capacity is always halved relative to differential operation (see the Using the AD8362 section).

## SQUARE-LAW DETECTION

The output of the variable-gain amplifier,  $V_{SIG}$ , is applied to a wideband square law detector, which provides a true rms response to this alternating signal that is essentially independent of waveform up to crest factors of 6. Its output is a fluctuating current,  $I_{SQU}$ , having a positive mean value. This current is integrated by an on-chip capacitance,  $C_F$ ; this is usually augmented by an external capacitance,  $CLPF$ , to extend the averaging time. The resulting voltage is buffered by a gain-of-5, dc-coupled amplifier whose rail-to-rail output,  $V_{OUT}$ , may be used either for measurement or control purposes.

In most applications, the AGC loop is closed via the setpoint interface pin,  $V_{SET}$ , to which the VGA gain-control voltage  $V_{SET}$  is applied. In measurement modes, the closure is direct and local by a simple connection from the output the  $V_{OUT}$  pin to the  $V_{SET}$  pin. In controller modes, the feedback path is around some larger system, but the operation is the same.

The fluctuating current,  $I_{SQU}$ , is balanced against a fixed setpoint target current,  $I_{TGT}$ , using current mode subtraction. With the exact integration provided by the capacitor(s), the AGC loop equilibrates when

$$MEAN(I_{SQU}) = I_{TGT} \quad (3)$$

The current  $I_{TGT}$  is provided by a second-reference squaring cell whose input is the amplitude-target voltage  $V_{ATG}$ . This is a fraction of the voltage  $V_{TGT}$  applied to a special interface that accepts this input at the  $V_{TGT}$  pin. Since the two squaring cells are electrically identical and are carefully implemented in the IC, process and temperature-dependent variations in the detailed behavior of the two square-law functions cancel.



# AD8362

Accordingly, VTGT (and its fractional part  $V_{ATG}$ ) determines the output that must be provided by the VGA for the AGC loop to settle. Since the scaling parameters of the two squarers are accurately matched, it follows that Equation 3 is satisfied only when

$$MEAN(V_{SIG}^2) = V_{ATG}^2 \quad (4)$$

In a formal solution, one would then extract the square root of both sides to provide an explicit value for the root-mean-square (rms) value. However, it is apparent that by forcing this identity, through varying the VGA gain and extracting the mean value by the filter provided by the capacitor(s), the system inherently establishes the relationship

$$rms(V_{SIG}) = V_{ATG} \quad (5)$$

Substituting the value of  $V_{SIG}$  from Equation 2, we have

$$rms[G_O V_{IN} \exp(-VSET/V_{GNS})] = V_{ATG} \quad (6)$$

As a measurement device,  $V_{IN}$  is the unknown quantity and all other parameters can be fixed by design. Solving Equation 6:

$$rms[G_O V_{IN}/V_{ATG}] = \exp(VSET/V_{GNS}) \quad (7)$$

so

$$VSET = V_{GNS} \log[rms(V_{IN})/V_Z] \quad (8)$$

The quantity  $V_Z = V_{ATG}/G_O$  is defined as the intercept voltage because  $VSET$  must be 0 when  $rms(V_{IN}) = V_Z$ .

When connected as a measurement device, the output of the buffer is tied directly to  $VSET$ , which closes the AGC loop. Making the substitution  $VOUT = VSET$  and changing the log base to 10, as needed in a decibel conversion, we have

$$VOUT = V_{SLP} \log_{10}[rms(V_{IN})/V_Z] \quad (9)$$

where  $V_{SLP}$  is the slope voltage, that is, the change in output voltage for each decade of change in the input amplitude. (Note that  $V_{SLP} = V_{GNS} \log(10) = 2.303 V_{GNS}$ ). In the AD8362,  $V_{SLP}$  is laser trimmed to 1 V using a 100 MHz test signal. Because a decade corresponds to 20 dB, this slope may also be stated as 50 mV/dB. It is later shown how the effective value of  $V_{SLP}$  may be altered by the user.

Likewise, the intercept  $V_Z$  is also laser trimmed to 316  $\mu$ V (–70 dBV). In an ideal system,  $VOUT$  would cross zero for an rms input of that value. In a single-supply realization of the function,  $VOUT$  cannot run fully down to ground; here,  $V_Z$  is the extrapolated value. In measurement modes, the output ranges from 0.5 V for  $V_{IN} = 1$  mV (input values are stated as rms, outputs values as dc), up to a voltage 60 dB  $\times$  50 mV/dB = 3 V above this for  $V_{IN} = 1$  V, that is, to 3.5 V. Figure 43 shows the ideal form of Equation 9 scaled as in the AD8362.

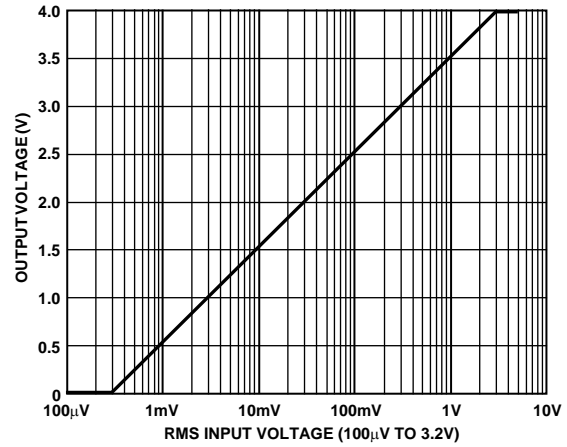

Figure 43. Ideal Response of the AD8362

## EFFECT OF INPUT COUPLING ON THE INTERCEPT VALUE

Reductions of  $V_{IN}$  due to coupling losses directly affect  $V_Z$ . In high frequency applications, several factors contribute to the coupling of the source into the IC, including the board and package resonances and attenuation. Any uncertainties in the input impedance result in the intercept expressed in power terms, which is nominally –57 dBm for a 50  $\Omega$  system, being less accurately determined than when stated in dBV (that is, in pure voltage) terms. On the other hand, the slope  $V_{SLP}$  is unaffected by all such impedance or coupling uncertainties.

## OFFSET ELIMINATION

To address the small dc offsets that arise in the variable gain amplifier, an offset-nulling loop is used. The high-pass corner frequency of this loop is internally preset to 1 MHz, sufficiently low for most HF applications. When using the AD8362 in LF applications, the corner frequency can be reduced as needed by the addition of a capacitor from the CHPF pin to ground having a nominal value of 200  $\mu$ F/Hz. For example, to lower the high-pass corner frequency to 150 Hz, a capacitance of 1.33  $\mu$ F is required. The offset voltage varies depending on the actual gain at which the VGA is operating, and thus, on the input signal amplitude.

Baseline variations of this sort are a common aspect of all VGAs, although more evident in the AD8362 because of the method of its implementation, which causes the offsets to ripple along the gain axis with a period of 6.33 dB. When an excessively large value of CHPF is used, the offset correction process may lag the more rapid changes in the VGA's gain, which may increase the time required for the loop to fully settle for a given steady input amplitude.



## VOLTAGE VS. POWER CALIBRATION

The AD8362 can be used as an accurate rms voltmeter from arbitrarily low frequencies to microwave frequencies. For low frequency operation, the input is usually specified either in volts rms or in dBV (decibels relative to 1 V rms). Driven differentially, the specified input range in dBV runs from  $-60$  dBV to  $0$  dBV (1 mV to 1 V rms). In these terms, the intercept is at  $-70$  dBV.

At high frequencies, signal levels are commonly specified in power terms. In these circumstances, the source and termination impedances are an essential part of the overall scaling. To set the AD8362's input impedance to  $50\ \Omega$ , it is necessary to add a resistor of  $66.7\ \Omega$  across the internal  $200\ \Omega$  differential input impedance of the IC. (This is discussed further in later sections.) For this condition, the intercept occurs at a nominal power level of  $-57$  dBm, and  $V_{OUT}$  can be stated in this way:

$$V_{OUT} = (P_{IN} + 57) \times 50\ \text{mV/dB} \quad (10)$$

where  $P_{IN}$  is expressed in dBm. For example, an input of  $-30$  dBm generates an output of 1.35 V.

## EFFECT OF SIGNAL WAVEFORM

The measurement accuracy of an rms-responding device is ideally unaffected by the waveform of the input signal. This is a valuable asset in wideband CDMA systems and in many other modulation modes where there is a significant amount of random variation of the RF carrier amplitude at baseband frequencies. The high accuracy of the AD8362 in such cases is indicated by the Typical Performance Characteristics graphs and in the Specifications table. Note that at low frequencies, it is customary to provide a specification of measurement errors due to waveform effects as a function of the crest factor ( $\sigma$ ) rather than in terms of a system-specific modulation mode.

When measuring signals whose waveforms have high but brief peak values (that is, having high crest factors), these peaks may be clipped, causing a reduction in the apparent value of the input being measured. This issue is discussed further in connection with the detailed description of the input system.

## OPERATION AT LOW FREQUENCIES

In conventional rms-to-dc converters based on junction techniques, the effective signal bandwidth is proportional to the signal amplitude. For a 1 MHz rms-to-dc converter, this is the full-scale bandwidth. However, at an input 60 dB below full-scale, the bandwidth could be as low as 1 kHz. In sharp contrast, the 3.5 GHz bandwidth of the VGA in the AD8362 is independent of its gain. Since this amplifier is internally dc-coupled, the system can also be used as a high accuracy rms voltmeter at low frequencies, retaining its temperature-stable decibel-scaled output, for example, in seismic, audio, and sonar instrumentation.

In such cases, the input coupling capacitors should be large enough so that the lowest frequency components of the signal that are to be included in the measurement are minimally attenuated. For example, for a 3 dB reduction at 1.5 kHz, capacitances of  $1\ \mu\text{F}$  are needed because the input resistance is  $100\ \Omega$  at each input pin ( $200\ \Omega$  differentially) and we calculate  $1/(2\pi \times 1.5\ \text{k}\Omega \times 100) = 1\ \mu\text{F}$ . Also, to lower the high-pass corner frequency of the VGA, a capacitor of value  $200\ \mu\text{F-Hz}$  should be used between the CHPF pin and ground; to provide a similar 1.5 kHz high-pass corner, a capacitor of 133 nF should be used.

## TIME-DOMAIN RESPONSE OF THE CLOSED LOOP

The external low-pass averaging capacitance, CLPF, added at the output of the squaring cell, is chosen to provide adequate filtering of the fluctuating detected signal. The optimum value depends on the application; as a guideline, a value of roughly  $900\ \mu\text{F-Hz}$  should be used. For example, a capacitance of  $5\ \mu\text{F}$  provides adequate filtering down to 180 Hz. Note that the fluctuation in the quasi-dc output of a squaring cell operating on a sine wave input is a raised cosine at twice the signal frequency, easing this filtering function.

In the standard connections for the measurement mode, the VSET pin is tied to  $V_{OUT}$ . For small changes in input amplitude (a few decibels), the time-domain response of this loop is essentially linear, with a 3 dB low-pass corner frequency of nominally  $f_{LP} = 1/(CLPF \times 1.1\ \text{k}\Omega)$ . Internal time delays around this local loop set the minimum recommended value of this capacitor to about 300 pF, giving  $f_{LP} = 3\ \text{MHz}$ .

When large and abrupt changes of input amplitude occur, the loop response becomes nonlinear and exhibits slew rate limitations. Further, due to the fundamentals of a system using transconductance squaring cells as employed in the AD8362, the slewing is asymmetric for increasing and decreasing inputs. Figure 44 shows typical waveforms for  $V_{OUT}$  for three values of  $V_{IN}$  using  $CLPF = 1\ \text{nF}$ .

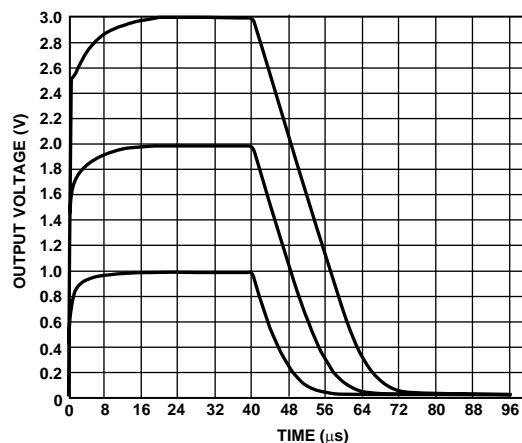

Figure 44. Typical Large-Scale Response



The most satisfactory way to quantify slew-rate limitations is by considering the peak currents that can be generated by the squaring cells. During a fast increase in input level, the peak current into the integrating (loop filter) capacitance, CLPF, is approximately 2.5 mA. The actual value depends on several factors, including the size of the step, and extremes in chip temperature. The voltage across the 1 nF capacitor thus increases at a rate of nominally 2.5 V/ $\mu$ s. Because the output buffer has a gain of 5, the output slew rate is 12.5 V/ $\mu$ s. The peak rate persists up to a point about 10 dB below the final value, after which the response gradually converges on the linear system response, as noted previously.

On the other hand, during a fast decrease in input level, the peak current in CLPF in the opposite (discharging) direction is much smaller; it is roughly 25  $\mu$ A. Thus, the slew rate for VOUT in the descending direction is only about 0.125 V/ $\mu$ s for CLPF = 1 nF. Discharging over the full 3 V range (a 60 dB reduction of input) requires a time interval of  $\sim$ 24  $\mu$ s. These figures are verified in the results shown in Figure 44.

### ALTERATION OF THE INTERNAL TARGET VOLTAGE

The AD8362 incorporates several features that extend its versatility. One of these is the ability to alter the target voltage. As noted, the output of the VGA is forced to a value set by the internal bias voltage ( $V_{ATG} = 0.06 \times VTGT$ ) applied to the reference squaring cell. It is normally set to 75 mV dc by connecting VTGT to the 1.25 V reference voltage at the VREF pin. However, it may optionally be varied from 0 V up to  $\pm 0.24$  V ( $\pm 4$  V at VTGT). Note that the sign of this input is unimportant, because it is internally squared.

By lowering  $V_{ATG}$ , the output of the VGA needed to balance the output currents of the two matched squaring cells is similarly lowered. This reduces the intercept in precisely the same ratio. Thus, if we halve the setpoint target voltage by halving the voltage applied to the VTGT pin, the intercept moves to the left (to a smaller input level) by 6.02 dB. This effectively doubles the measurement system's sensitivity.

Furthermore, because the signal amplitude needed to drive the squaring cell is halved, the output stage of the VGA now has twice the dynamic headroom (before clipping) and can handle waveforms having crest factors that are twice as large. Figure 45 shows the overall response for an illustrative set of values of VTGT = 0.3 V, 0.533 V, 0.949 V, 1.687 V, and 3.0 V. While this is usually a fixed dc voltage, it can also be a time-varying, unipolar or bipolar voltage, in which case the overall operation is rather more complex. For example, when VTGT is derived from VOUT, the dynamic range can be extended to over 80 dB. Examples of such uses of this feature are presented later.

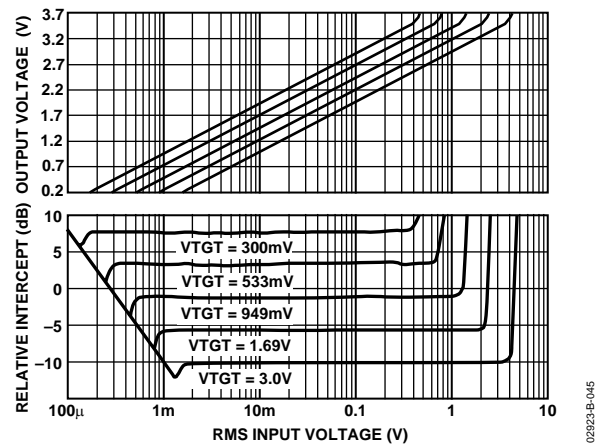

Figure 45. Response with VTGT Varied from 0.3 V to 3 V in 5 dB Steps, Showing the Proportional Shift in Intercept

### EFFECTS AT EACH END OF DYNAMIC RANGE

All AGC loops have a limited minimum and maximum input beyond which the system cannot respond correctly. However, the output of a well-behaved system is in error in such a way as to avoid anomalous measurements. For an input below its minimum capability, the output should not turn around to falsely indicate a higher input value; for inputs above its maximum capability, the output should not fold over and return to some lower value.

The actual behavior of the AD8362 under these conditions can be seen in the set of plots in Figure 45, the lower panel of which shows the deviation from the ideal response with a slope of 50 mV/dB. For inputs below a certain level corresponding to the point at which the VGA is operating at its maximum gain, its output can no longer meet the rms amplitude target set by VTGT, so the output moves quickly to its minimum value in an attempt to provide the needed extra gain. As VTGT is altered, the corresponding end-limit voltage moves to the left or to the right.

On the other hand, when the input is above a certain upper limit where the VGA gain has been driven to its minimum gain, any further increase drives its output well above the target voltage needed to balance the loop. The resulting integration of this internal error signal causes VOUT to rise abruptly. In either case, this output takes on a safe value and does not fold back under any conditions.

The dynamic range, the “dB distance” between these limits, is not basically dependent on VTGT. The middle line in the plots of Figure 45 (VTGT = 0.949 V) extends from 0.5 mV to 1.5 V between the  $\pm 1\%$  error points; the dynamic range is thus slightly over 68 dB. For other values of VTGT, this basic 68 dB range just moves to the left or to the right.



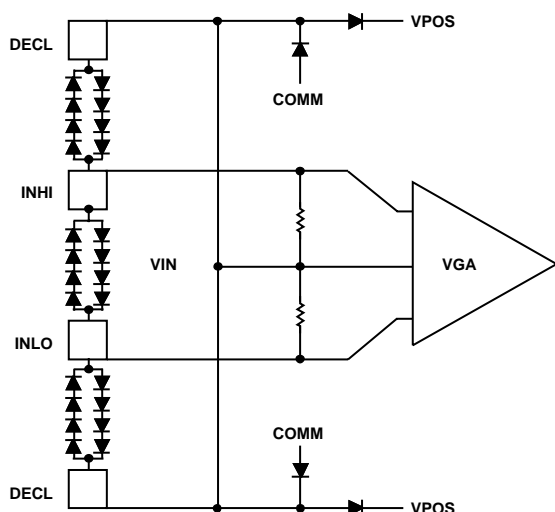

Figure 46. Input Protection at INHI and INLO Pins

## INPUT PROTECTION

Like all robust ICs, the AD8362 requires input protection against high voltage transients at the input (ESD). However, the techniques normally used for this purpose, based on breakdown diodes from the input pins INHI and INLO to the supply pins VPOS and COMM, cannot be used here because this raises the risk of excessive signal coupling to internal nodes at the upper end of the frequency range due to feedthrough in the capacitances of these diodes. Package inductances cause all internal nodes, including the supply and common lines, to have a significant impedance back to the external ground plane; even small disturbances on these nodes can cause anomalous operation.

This risk is particularly evident because the main amplifier in the AD8362's VGA (an advanced X-AMP®) operates at full gain under all conditions, while the signal input is variably attenuated. Because this attenuation may be as high as 70 dB, very small feedthrough effects in the 0.5 GHz to 3 GHz range can have a pronounced impact on measurement accuracy.

Figure 46 shows the protection method used. The multiple diodes arranged in back-to-back pairs limit the voltage swing on the input pins by clamping to the two DECL pins, which form a common ac low impedance node for the attenuators, independently grounded via two external capacitors. The HF currents in the capacitances of these diodes are thus shunted directly to a signal null point.

An unavoidable consequence of this method is that the diodes will forward-conduct when the input amplitude is sufficient. This is not an all-or-nothing effect, of course; they shunt the input progressively as the signal increases. This conduction is strongest at high temperatures when the forward drop voltage of these diodes is lowest. The overall consequence is that high amplitude peaks are clamped to a greater or lesser degree. This affects the measurement accuracy at the top extreme of the dynamic range whenever the signal waveform has a high crest factor. These effects are, of course, included in the overall performance specifications.

## POWER-ENABLE RESPONSE TIME

The operating and standby currents for the AD8362 at 27°C are 24 mA and 275  $\mu$ A, respectively. The power-down mode is activated by a logic high on the PWDN pin. When the shutdown feature is used, the normal operating conditions are restored relatively quickly when this pin is taken low.

Figure 47 shows typical response times for a midscale signal ( $V_{IN} = 50$  mV). The output rises to within 0.1 dB of its steady-state value in about 20  $\mu$ s; the reference voltage is available to full accuracy in a much shorter time. This wake-up response varies in detail depending on the input coupling means and the capacitances  $C_{DEC}$ ,  $CHPF$ , and  $CLPF$ . These results are for a measurement system operating in the 0.8 GHz to 2 GHz range, balun coupled at the input port, with  $C_{DEC} = 1$  nF,  $CHPF = 0$ , and  $CLPF = 1$  nF.

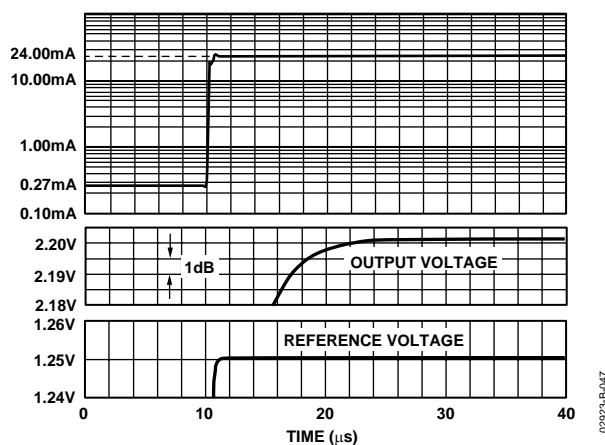

Figure 47. Typical Wake-Up Response;  $t_o = 10 \mu$ s



# AD8362

## USING THE AD8362

The AD8362 requires a single supply of nominally 5 V; its performance is essentially unaffected by variations of up to  $\pm 10\%$ , the range over which the stated specifications apply. Supplies as low as 2.7 V may be used with some loss of performance at high inputs and at temperature extremes.

The AD8362 is disabled by a logic high on the PWDN pin, which may be directly grounded for continuous operation, when the supply current at 27°C is nominally 24 mA and essentially independent of supply voltage. When powered down by a logic low on PWDN, the supply current is reduced to about 275  $\mu\text{A}$ .

### BASIC CONNECTIONS

The supply is connected to the VPOS pin using the decoupling network shown in Figure 48, whose capacitors must provide a low impedance over the full frequency range of the input, and should be placed as close as possible to the VPOS pin. Two different capacitors are used in parallel to reduce the overall impedance since these have different resonant frequencies. However, the measurement accuracy is not critically dependent on supply decoupling because the high frequency signal path is confined to the relevant input pins. It is more important that the lead lengths to INHI and INLO, and in the decoupling capacitors from both of the DECL pins to ground, and the connections from COMM to the ground plane all use the shortest possible connections.

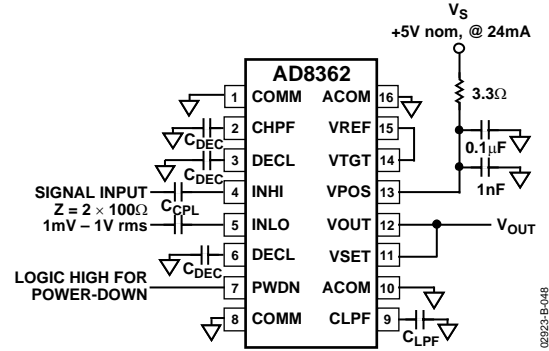

Figure 48. Basic Measurement Mode Connections



## MAIN MODES OF OPERATION

Both measurement and controller modes are supported by the AD8362. Typical connections for the measurement mode, which may also be viewed as the rms voltmeter mode, are also illustrated in Figure 48. The output, VOUT, is proportional to the logarithm of the rms magnitude of the input signal (that is, a linear-on-dB response). When used in an accurately known system impedance (but only then), the output is a scaled decibel measurement of the power represented by the input voltage.

The choice of the capacitances  $C_{CPL}$ ,  $C_{DEC}$ ,  $CHPF$ , and  $CLPF$  depends on the lowest frequency to be included in the measurement spectrum. The default values shown support operation down to 100 Hz. Using a large enough value of  $CLPF$  (10  $\mu$ F) to ensure sufficient filtering at this low input frequency, the response time is approximately 20 ms over most of the dynamic range. In high frequency applications, this capacitor is much smaller and is usually chosen to minimize the response time, consistent with well-behaved, large-signal behavior. In this figure,  $CHPF$  is also shown as 10  $\mu$ F, to lower the high-pass corner to about 90 Hz. However, no capacitor will be needed here in most HF applications since the internally set high-pass corner is at about 2 MHz.

Comparing the controller mode illustrated in Figure 49, the AD8362 is used here to monitor the output of a variable gain (or variable output power) signal processing element, frequently a power amplifier, and adjust its output to a desired target value (the setpoint) under the control of VSET. In this mode, its function is somewhat like an RF comparator. With the path from VOUT to VSET broken, any input larger than the corresponding setpoint causes VOUT to rail to its maximum value (which might loosely be viewed as a logic high). For inputs smaller than the setpoint, the controller's output falls to a near-ground level (logic low). Using the AD8362 simply as a threshold detector, this viewpoint may be useful, but in most applications, it is an oversimplification. The AD8362 invariably operates with the control loop closed, either locally with VOUT connected to VSET (as in measurement mode), or globally via some external nonlinear element (as in controller mode).

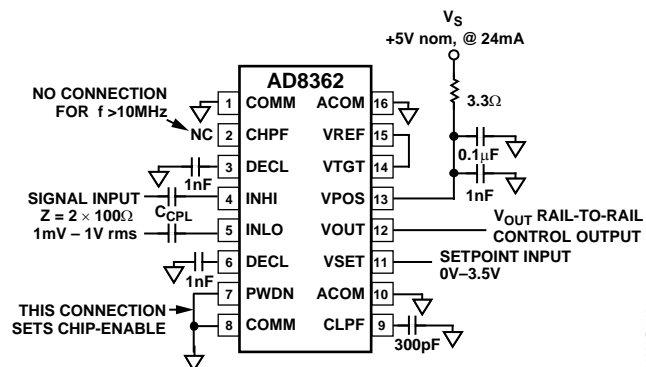

Figure 49. Basic Controller Mode Connections

Controller mode operation is more closely analogous to that of a classical proportional/integral/derivative (PID) loop. The error corresponding to the decibel deviation from the setpoint is integrated by current into a capacitor (the sum of the internal and external capacitance  $CLPF$ ) until such deviation is nulled. This action provides the fundamental proportional part of the loop response (although VOUT has decibel scaling). The Q of this system can be adjusted to minimize the loop response time by including a resistor in series with  $CLPF$ , generating a transmission zero, which provides the derivative term of a standard PID loop.

As a simple example, assume that the AD8362 operates at an input power level of  $-20$  dBm re:  $50 \Omega$ . Connected in the measurement mode, it generates a VOUT of 2.00 V, because this input is  $+40$  dB above the intercept at  $-60$  dBm and is scaled to 50 mV/dB. Rearranged to the controller mode with exactly this voltage now externally applied to the VSET pin, the loop forces VOUT to the control voltage required by the gain element to provide a power sample of  $-20$  dBm.

Of course, any control loop of this sort operates correctly only if VSET corresponds to a power level (or a small sample of such) that can actually be provided by the external gain element. When this is a power amplifier, including the required amount of RF attenuation ensures this condition. In certain instrumentation situations, it may be necessary to provide some low noise gain ahead of the AD8362's input.

These two primary modes of use are discussed in more detail, with emphasis on practical considerations.



# AD8362

## OPERATION IN MEASUREMENT MODES

Figure 50 shows the general connections for operating the AD8362 as an RF power detector, more correctly viewed as an accurate measurement system. The full performance potential of this part, particularly at very high frequencies (above 500 MHz), is realized only when the input is presented to the AD8362 in differential (balanced) form. In this example, a flux-coupled transformer is used at the input. Having a 1:4 impedance ratio (1:2 turns ratio), the 200 Ω differential input resistance of the AD8362 becomes 50 Ω at the input to the transformer, whose outputs can be connected directly to INHI and INLO. If a center-tapped transformer is used, connect the tap to the DECL pins, which are biased to the same potential as the inputs (~3.6 V). Over the 0.9 GHz to 2.2 GHz range, a transmission line transformer (balun) may be used, as explained later. (The evaluation board is supplied with a M/A-COM ETC1.6-4-2-3, 0.5 GHz to 2.5 GHz, 4:1 balun.)

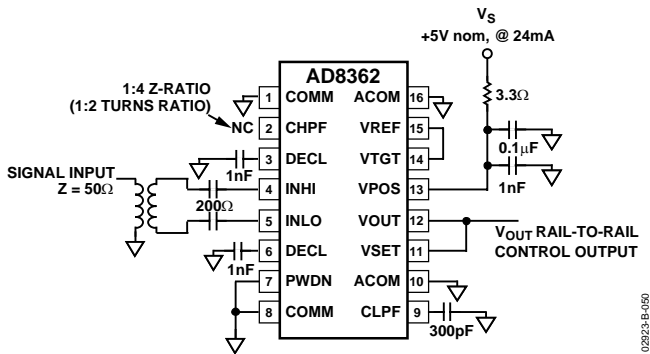

Figure 50. Connections for RF Power Measurement

The output in this mode of use is a continuous, decibel-scaled voltage ranging from about 0.5 V to 3.5 V.

$$V_{OUT} = (P_{IN} P_Z) \times 50 \text{ mV/dB} \quad (11)$$

The equivalent input power,  $P_{IN}$ , is expressed in dBm (decibels above 1 mW) in a particular system impedance, which in this case is 50 Ω. The intercept,  $P_Z$ , is that input power for which the back-extrapolated output crosses zero. Expressed as a voltage, it is 0.447 mV rms (−67 dBV, laser-calibrated at 100 MHz), corresponding to a  $P_Z$  of −60 dBm in 200 Ω. However, the 1:2 turns ratio of the transformer halves the required input voltage, which moves the intercept down by 6 dB to 0.224 mV rms (−73 dBV) at the transformer's input.

Impedance mismatches and attenuation in the coupling elements significantly affect the intercept position. This error is stable over temperature and time, and thus can be removed during calibration in a specific system. The logarithmic slope of 50 mV/dB varies only slightly with frequency; corrected values for several common frequencies are provided in the Specifications section.

## LAW CONFORMANCE ERROR

In practice, the response deviates slightly from the ideal straight line suggested by Equation 11. This deviation is called the law conformance error. In defining the performance of high accuracy measurement devices, it is customary to provide plots of this error. In general terms, it is computed by extracting the best straight line to the measured data using linear regression over a substantial region of the dynamic range and under clearly specified conditions.

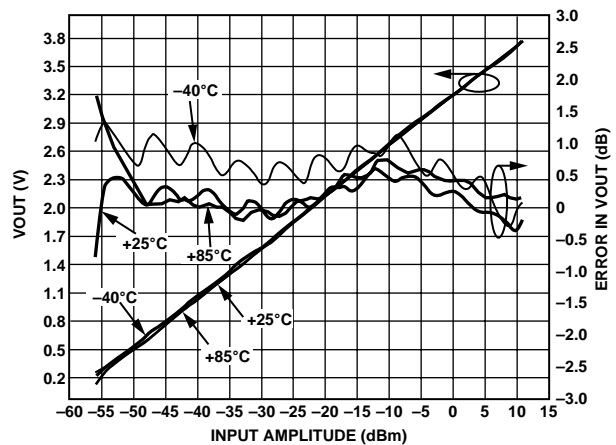

Figure 51. Output Voltage and Law Conformance Error, at  $T_A = -40^\circ\text{C}$ ,  $+25^\circ\text{C}$ , and  $+85^\circ\text{C}$

Figure 51 shows the output of the circuit of Figure 50 over the full input range. The agreement with the ideal function (law conformance) is also shown. This was determined by linear regression on the data points over the central portion of the transfer function (35 mV to 250 mV rms) for the 25°C data. The error at +25°C, −40°C, and +85°C was then calculated by subtracting the ideal output voltage at each input signal level from the actual output and dividing this quantity by the mean slope of the regression equation to provide a measurement of the error in decibels (scaled on the right-hand axis of Figure 51).

The error curves generated in this way reveal not only the deviations from the ideal transfer function at a nominal temperature but also all of the additional errors caused by temperature changes. Notice there is a small temperature dependence in the intercept (the vertical position of the error plots); this variation is within 0.5 dB at high powers.

Figure 51 further reveals that there is a periodic ripple in the conformance curves. This is due to the interpolation technique used to select the signals from the attenuator, not only at discrete tap points, but anywhere in between, thus providing continuous attenuation values. The selected signal is then applied to the 3.5 GHz, 40 dB fixed gain amplifier in the remaining stages of the AD8362's VGA.



An approximate schematic of the signal input section of the AD8362 is shown in Figure 52. The ladder attenuator is composed of 11 sections (12 taps), each of which progressively attenuates the input signal by 6.33 dB. Each tap is connected to a variable transconductance cell whose bias current determines the signal weighting given to that tap. The interpolator determines which stages are active by generating a discrete set of bias currents, each having a Gaussian profile. These are arranged to move from left to right, thereby determining the attenuation applied to the input signal as the gain is progressively lowered over the 69.3 dB range under control of the VSET input. The detailed manner in which the transconductance of adjacent stages varies as the virtual tap point slides along the attenuator accounts for the ripple observed in the conformance curves. Its magnitude is slightly temperature dependent and also varies with frequency (see Figure 10 to Figure 12). Notice that the system's responses to signal inputs at INHI and INLO are not completely independent; these pins do not constitute a fully floating differential input.

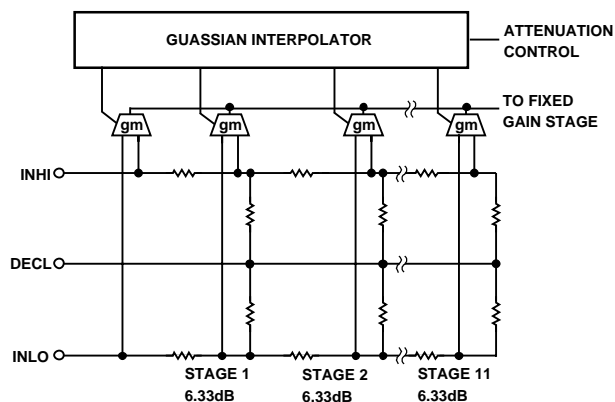

Figure 52. Simplified Input Circuit

## ALTERNATIVE INPUT COUPLING MEANS

The input stages of the AD8362 are optimally driven from a fully balanced source, which should be provided wherever possible. The ac low sides of both halves of the attenuator internally connect to the DECL pin, which is therefore the RF signal low terminal for both INHI and INLO. In many cases, unbalanced sources can be applied directly to one or the other of these two pins. The chief disadvantage of this driving method is a reduction in dynamic range, particularly at very high frequencies.

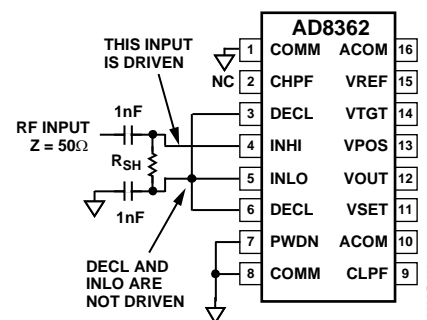

Figure 53. Input Coupling from a Single-Ended Source

Figure 53 illustrates one of many ways of coupling the signal source to the AD8362. Because the input pins are biased to about 3.6 V (for  $V_s = 5$  V) dc-blocking capacitors are required when driving from a grounded source. For signal frequencies  $>5$  MHz, a value of 1 nF is adequate. While either INHI or INLO may be used, INHI is chosen here, and INLO is connected to the low side of the source. The resistor  $R_{SH}$  is not needed if a 100  $\Omega$  termination is acceptable. The corresponding intercept is still  $-67$  dBV, that is, 447  $\mu$ V rms. However, specified in power terms at 100  $\Omega$ , the  $P_z$  is now at 2 nW or  $-57$  dBm.

For a source termination of 50  $\Omega$ , the internal 100  $\Omega$  from INHI to DECL must be shunted by a chip resistor of 100  $\Omega$ . At high frequencies, a low attenuation pad at the input improves the VSWR. For example, with a resistor of  $R_{SH} = 33$   $\Omega$  and an added resistor of 25  $\Omega$  from the source to INHI, a termination of 50  $\Omega$  is provided, with 6 dB of attenuation, raising the intercept to  $-48$  dBm.

## USING A NARROW-BAND INPUT MATCH

While transformers offer the simplest method for providing single-sided to balanced conversion, a good alternative is using a specially designed narrow-band LC network, shown in Figure 54, which also provides an input match. Using this basic formulation, the match is to 50  $\Omega$ , with a voltage gain of 1.5 (3.56 dB) from the input connector to the AD8362. This network is specially designed to provide a high degree of amplitude balance at INHI and INLO as well as an exact phase inversion. The narrow-band match provides a useful degree of frequency selectivity, and the capacitors also serve to provide the required dc blocking.

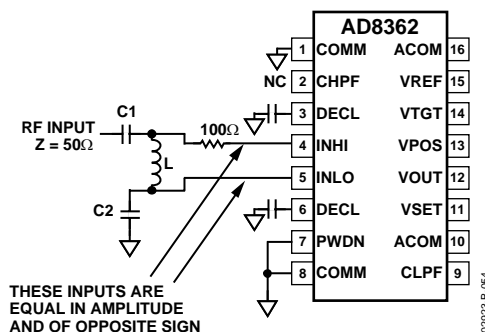

Figure 54. Narrow-Band Reactive Input Coupling



# AD8362

The network can readily be scaled to other frequencies by varying the product LC, while keeping the ratio L/C constant to preserve a 50 Ω input impedance. Table 4 provides some spot values; these take into account the reactive Z<sub>IN</sub> of the AD8362.

**Table 4. Suggested Components for Narrow-Band 50 Ω Match**

Frequency (MHz)	L (nH)	C1 (pF)	C2 (pF)
1	21850	2230	2765
2	10925	1115	1383
5	4370	446	553
10	2185	223	276
20	1093	112	138
50	437	45	55
100	220	22	27
200	100	10	12
500	40	3.9	4.7

This coupling method can be used down to much lower frequencies than shown in Table 4 simply by multiplying the 1 MHz component values proportionally. The effects of the reactive components of the AD8362's inputs above 500 MHz may require some fine tuning of the suggested values. In the gigahertz region, the input coupling is usually more effectively implemented using a balun.

## UNCERTAINTIES IN R<sub>IN</sub> AND POWER CALIBRATION

In all the cases where a 50 Ω to 200 Ω transformation is implemented, the voltage gain is only nominally ×2 (6 dB). This ideal is impaired by the fact that the input resistances of the AD8362 are not precise; variations of ±20% can be expected from lot to lot. Therefore, it is necessary to use a calibration step whenever an accurate value for the power intercept, P<sub>Z</sub>, must be established.

When driven differentially, a significant improvement in intercept accuracy can be achieved by shunting the 200 Ω resistance from INHI to INLO with a 66.5 Ω resistor to set the differential input resistance to 50 Ω. Assuming a tolerance of ±20% for the basic R<sub>IN</sub> and ±1% for the chip resistor, the net input resistance could exhibit an error of ±2.5%. The resulting error in P<sub>Z</sub> (and thus in the absolute power measurement) may vary from -0.26 dB to +0.21 dB.

These precautions regarding input impedance do not apply when the input is presented in voltage form, as is often the case at low frequencies, or when the source impedance is low compared to 200 Ω. For example, when using a feedback amplifier as an impedance buffer ahead of the input, as in the example in Figure 61, the loss at the interface at moderate frequencies is negligible.

## CHOOSING THE RIGHT VALUE FOR CHPF AND CLPF

The AD8362's 3.5 GHz variable gain amplifier includes an offset cancellation loop, which introduces a high-pass filter effect in its transfer function. The corner frequency, *f*<sub>HP</sub>, of this filter must be below that of the lowest input signal in the desired measurement bandwidth frequency to properly measure the amplitude of the input signal. The required value of the external capacitor is given by

$$CHPF = 200\mu\text{F}/f_{HP} \text{ (} f_{HP} \text{ in Hz)} \quad (12)$$

Thus, for operation at frequencies down to 100 kHz, CHPF should be 2 nF.

In the standard connections for the measurement mode, the VSET pin is tied to VOUT. For small changes in input amplitude (a few decibels), the time-domain response of this loop is essentially linear with a 3 dB low-pass corner frequency of nominally *f*<sub>LP</sub> = 1/(CLPF × 1.1 kΩ). Internal time delays around this local loop set the minimum recommended value of this capacitor to about 300 pF, making *f*<sub>LP</sub> = 3 MHz.

For operation at lower signal frequencies, or whenever the averaging time needs to be longer, use

$$CLPF = 900\mu\text{F}/f_{LP} \text{ (} f_{LP} \text{ in Hz)} \quad (13)$$

When the input signal exhibits large crest factors, such as a WCDMA signal, CLPF must be much larger than might at first seem necessary. This is due to the presence of significant low frequency components in the complex, pseudo-random modulation, which generates fluctuations in the output of the AD8362.

## USE OF NONSTANDARD TARGET VOLTAGES

An external connection between VREF and VTGT sets up the internal target voltage, that is, the rms voltage that must be provided by the VGA to balance the AGC feedback loop. In the default scheme, the VREF of 1.25 V positions this target to 0.06 × 1.25 V = 75 mV. In principle, however, VTGT may be driven by any voltage in the range -4 V to +4 V (the sign is ignored) to alter this target, either in a fixed or dynamic way.

For example, if this pin is supplied from VREF via a simple resistive attenuator of 1 kΩ:1 kΩ, the output required from the VGA is halved (to 37.5 mV rms), which moves the nominal intercept to -73 dBV. Under these conditions, the effective headroom in the signal path that drives the squaring cell is doubled. In principle, this doubles the peak crest factor that may be handled by the system.

If VTGT is reduced too far, the accuracy and stability of the intercept are compromised. The currents generated by the transconductance mode squaring cells become smaller by the square of the ratio. Thus, a factor of 5 reduction in VTGT



lowers the signal currents in the squaring cells by a factor of 25. As well as making the system more sensitive to small static errors (offsets) in the postdetection circuitry, such a reduction also reduces the peak slew rate. A suitable adjustment to the value of CLPF is needed to maintain a given AGC loop bandwidth. On the other hand, increasing the target voltage can improve the accuracy and stability of the intercept for low crest factor signals. Thus, using  $VTGT = 2.5\text{ V}$ , the peak output currents of the squaring cell are quadrupled and the peak slew rate is increased by the same factor. CLPF should be increased to maintain an adequate stability margin in the AGC loop.

In many applications, it is useful to use a nonstandard value of VTGT to shift the measurement range by a constant amount to accommodate either a reduced or increased range of signal inputs. The dynamic span remains >60 dB for such changes. This technique is particularly useful when the sensitivity can be lowered by raising VTGT, and there is little expectation of high crest factor signals.

## ADJUSTING THE INTERCEPT

Another way to take advantage of the effect of VTGT is to use it to introduce an adjustment to the log intercept, represented by the voltage  $V_Z$  in Equation 14. Formally, this can be expressed in terms of a modified value of  $V_Z'$ .

$$V_Z = V_Z VTGT / 1.25 V \quad (14)$$

A lower VTGT effectively increases the sensitivity of the measurement system, which is just another way of stating that the intercept moves to a lower value. This raises VOUT for all input amplitudes, as demonstrated by the plots in Figure 45. This control of the measurement system's intercept could therefore be brought about by applying the output of a DAC to the VTGT pin, if that suits the overall objectives of an application.

For many purposes, a small manual adjustment range of  $\pm 3\text{ dB}$  is sufficient. This can be implemented as shown in Figure 55. Here, the largest fraction of VTGT is still provided by the built-in reference to minimize the sensitivity to supply voltage variations. Now a variable component is provided by the trim network. For a 5 V supply, this added component of VTGT is 0 when VR1 is centered. With the slider closest to ground, VTGT is lowered by 366 mV, which corresponds to a 3 dB decrease in intercept; in the opposite condition, it is raised by 518 mV, which increases the intercept by 3 dB. That is, VTGT ranges from  $1.25\text{ V}/\sqrt{2}$  to  $\sqrt{2} \times 1.25\text{ V}$ .

Other adjustment ranges can be readily calculated from this example. The resistance at the VTGT pin is nominally 52 k $\Omega$ ; resistor values should be calculated with this in mind. In some situations, this control interface might be driven from a programmable source. In the simplest case, a logic level could provide two intercept values, differing by say, 10 dB, thus providing essentially two switched input ranges.

Also, it is worth remembering that these shifts in intercept are equivalent, in most respects, to a dc offset applied to the AD8362's output, with the main differences being that:

- Varying VTGT affects the crest factor capacity to some extent
- This technique makes better use of the available output range than a post-VOUT adjustment would

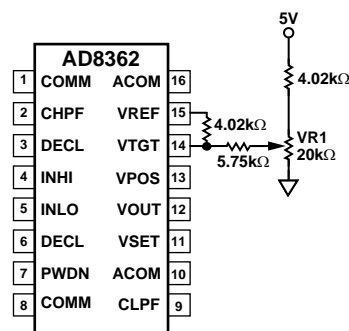

Figure 55. Adjustments of the Intercept by  $\pm 3\text{ dB}$

## ALTERING THE SLOPE

None of the changes in operating conditions discussed so far affect the logarithmic slope,  $V_{SLP}$ , in Equation 9. However, this can readily be altered by controlling the fraction of VOUT that is fed back to the setpoint interface at the VSET pin. When the full signal from VOUT is applied to VSET, the slope assumes its nominal value of 50 mV/dB. It can be increased by including an attenuator between these pins, as shown in Figure 56. Moderately low resistance values should be used to minimize scaling errors due to the 70 k $\Omega$  input resistance at the VSET pin. Keep in mind that this resistor string also loads the output, and it eventually reduces the load-driving capabilities if very low values are used. To calculate the resistor values, use

$$R1 = R2' (S_D / 50 - 1) \quad (15)$$

where  $S_D$  is the desired slope, expressed in mV/dB, and  $R2'$  is the value of R2 in parallel with 70 k $\Omega$ . For example, using  $R1 = 1.65\text{ k}\Omega$  and  $R2 = 1.69\text{ k}\Omega$  ( $R2' = 1.649\text{ k}\Omega$ ), the nominal slope is increased to 100 mV/dB. This choice of scaling is useful when the output is applied to a digital voltmeter because the displayed number reads as a decibel quantity directly, with only a decimal point shift.

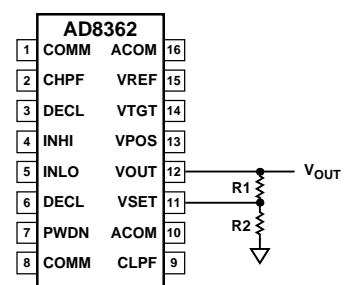

Figure 56. External Network to Raise Slope



# AD8362

Operation at high slopes is useful when a particular subrange of the input is measured in greater detail. However, a measurement range of 60 dB would correspond to a 6 V change in  $V_{OUT}$  at this slope, exceeding the capacity of the AD8362's output stage when operating on a 5 V supply. This requires that the intercept is repositioned to place the desired subrange within a window corresponding to an output range of  $0.2\text{ V} \leq V_{OUT} \leq 4.8\text{ V}$ , a 46 dB range.

Using the arrangement shown in Figure 57, an output of 0.5 V corresponds to the lower end of the desired subrange, and 4.5 V corresponds to the upper limit with 3 dB of margin at each end of the range, which is nominally 3 mV rms to 300 mV rms, with the intercept at 1.9 mV rms. Note that R2 is connected to VREF rather than ground. R3 is needed to ensure that the AD8362's reference buffer, which can sink only a small current, is correctly loaded.

It is apparent that a variable attenuation factor based on this scheme could provide a manual adjustment of the slope, but there are few situations in which this is of value. When the slope is raised by some factor, the loop capacitor, CLPF, should be raised by the same factor to ensure stability and to preserve a chosen averaging time. The slope can be lowered by placing a two-resistor attenuator after the output pin, following standard practice.

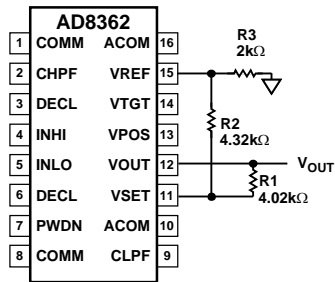

Figure 57. Scheme Providing 100 mV/dB Slope for Operation over a 3 mV to 300 mV Input Range

## ENVELOPE ELIMINATION MODE

The VTGT input can be used to track the AM modulation envelope on an RF signal to affect a form of envelope elimination. The modulation waveform must be known and a sample must be available as a baseband voltage. Using this voltage as VTGT, the AD8362 tracks this envelope when demodulation is realized by the squaring cell. So if the envelope output of the main amplifier should, for example, double over some interval while the target voltage that satisfies the AGC loop criterion also doubles, the net effect is that the gain of the amplifier does not need to change to keep the loop balanced.

That being the case, the gain-control voltage, VSET, likewise does not need to change. It follows that the output is free of fluctuations. In measurement mode, that voltage is also the output, so it also remains at a constant value as the modulation varies the input magnitude. The bandwidth of the dc-coupled amplifier in the AD8362 that buffers VTGT has been kept high (~300 MHz) so that even fast AM modulation envelopes can be accurately tracked.

Figure 58 shows an example. As depicted in the top panel of Figure 59, the input to the AD8362 is a pure, ideal, sinusoidal 100 MHz carrier that is amplitude modulated at 100 kHz by another pure sine wave. A suitably scaled sample of the modulation voltage is also applied to the VTGT pin. In this example, its average value is 1.25 V (the normal bias level for VTGT), and the amplitude is 0.75 V. Therefore VTGT ranges from 0.5 V to 2 V, corresponding to a factor of 4 change (16 dB) in the target voltage over each cycle of the modulation. The resulting  $V_{OUT}$  waveform is of essentially constant value at about 2.5 V, as shown in Figure 59; this is compared with the deeply fluctuating output for a fixed VTGT of 1.25 V.

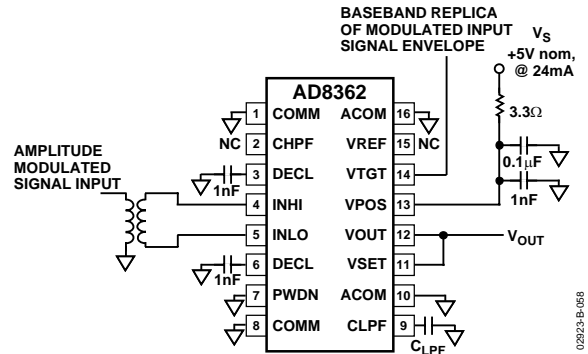

Figure 58. Envelope Elimination Using the VTGT Interface

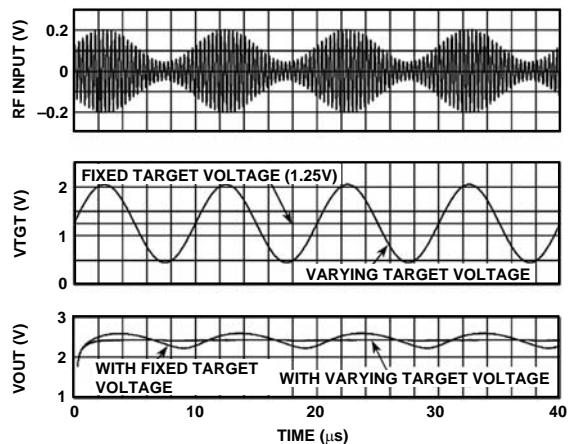

Figure 59. Waveforms for Envelope Elimination Scheme



## OPERATOR IN CONTROLLER MODES

In order to fully understand this section, it is important to first read the preceding discussion of measurement modes, because there are only a few differences in operation and connections. When used in controller applications, the basic objective is to use the AD8362 as a level-sensing element in such a way that its output, here  $V_{APC}$ , moves in a direction that increases the controlled signal when the input sample is too low, and vice versa. A general scheme is shown in Figure 60.

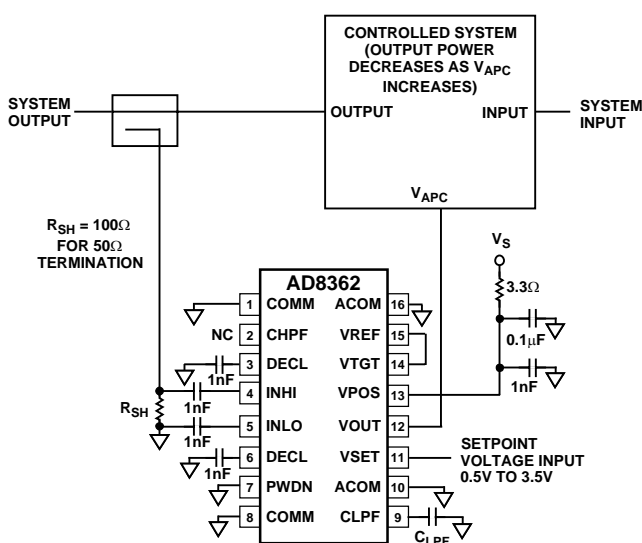

Figure 60. Generalized Control Loop Using the AD8362

Because the AD8362 integrates any input error relative to the setpoint, and ideally would fully null this error over an appropriate time interval, it follows that  $V_{APC}$  swings rail-to-rail over a very narrow range of inputs. In practice, a few millidecibels of amplitude deviation at the input fully swing the output.

The signal input level at which this occurs (the setpoint) is determined by the control voltage, VSET. This voltage defines the narrow range of the ac input over which the AD8362's output is most sensitive to the absolute input magnitude. In base stations, for example, VSET is often delivered by the ramp DAC, and the setpoint is a rapidly varying sequence of levels during the ramp-up and ramp-down intervals of each burst as well as with output power demand variations from one channel to another.

Every value of VSET maps uniquely to a specific rms value at its input. Thus, the major loop shown in Figure 60 forces the system being controlled to deliver exactly this level (which may be either in voltage form or as a sample of the power output). This mode of operation is therefore just an extension of the measurement mode, having exactly the same scaling (slope and intercept) at the VSET pin.

When the system in Figure 60 is an RF power amplifier (PA), a practical consideration immediately comes to our attention. Frequently, the gain (and thus output power) is arranged to increase in response to an increasing positive voltage applied to the gain control pin. However, the AD8362's output tends toward higher values as its input crosses over the level corresponding to the setpoint, which would cause the PA's output to increase further. In other words, the feedback polarity is reversed, forcing the control loop to latch up at one of its power extremes.

An increasing number of modular PAs feature a control polarity that reduces the power output with increases in control voltage. These can be controlled directly from the VOUT pin of the AD8362. Elsewhere, it is necessary to provide the sign inversion using a low noise buffer. This amplifier may also include provisions to ensure that the PA is never driven beyond its safe limits. The complete details of such a control system depends on many factors, and this example shows only generic aspects of the design.

### USE OF AN INPUT BALUN

A balun (balance to unbalance) is used either to transform differential RF signals to single-ended form or in reverse to convert single-sided signals to differential form. A typical balun consists of a short length of transmission line (miniature coaxial or twisted pair) through which the signal passes without significant degradation, wound on a core (often a ferrite) to generate a series mode inductor having a high reactive impedance, compared to the through-mode impedance of the transmission line, which is often 50 Ω.

High frequency common-mode voltages applied to the input of this line are sustained across this series reactance and do not appear at the loaded side of the line. On the other hand, the through-mode bandwidth is very high, and the losses incurred in a short line of this sort are trivial.

Baluns of slightly more elaborate construction can provide an impedance transformation (usually designated by their impedance ratio, for example, 4:1, which becomes a 1:4 ratio when used in reverse) in order to convert a single-sided signal to the balanced form, as is desirable in driving the AD8362, while also presenting a 50 Ω input interface.



## AD8362

The evaluation board for the AD8362 includes a 1:4 balun, part number M/A-COM ETC1.6-4-2-3, providing low loss coupling from 0.5 GHz to 2.5 GHz and an impedance transformation from the board's 50  $\Omega$  input (at the SMA connector) to the 200  $\Omega$  differential input resistance of the AD8362. At high frequencies, the actual impedance at the connector is influenced by reactive aspects of the IC's input impedance. Because these can alter the magnitude of the input voltage, the logarithmic intercept cannot be precisely specified. However, the shift is temperature stable.

Note that the balun used here increases the signal voltage by the square root of its impedance ratio of 4:1, in this case by a factor of 2. The use of a transformer to match the 500  $\Omega$  source to the 200  $\Omega$  load presented by the AD8362 thus increases the effective sensitivity of the measurement system by 6 dB, whether specified in dBV or dBm at the input to the transformer.



## GENERAL APPLICATIONS

The unusual versatility of the AD8362 opens up many new possibilities whenever an element having an accurate rms response is needed. Developed primarily to address the need for true power measurement in communications systems operating at frequencies as high as 2.7 GHz, the AD8362 is capable of meeting the requirements of instrumentation at much lower frequencies. As noted earlier, the AD8362 is unique in providing rms-to-dc conversion with a completely constant bandwidth regardless of signal amplitude and in providing a calibrated linear-in-dB measurement.

Caution: The applications shown in Figure 61 are provided only for illustrative purposes and should not be regarded as ready for immediate incorporation into a user's system. They have been validated for the present purpose by simulation studies.

### RMS VOLTMETER WITH >100 dB DYNAMIC RANGE

The 60 dB range of the AD8362 can be extended by adding a standalone VGA as a preamplifier whose gain control input is derived directly from VOUT. This extends the dynamic range by the gain control range of this second amplifier. When this VGA also provides a linear-in-dB (exponential) gain control function, the overall measurement remains linearly scaled in decibels. The VGA gain must decrease with an increase in its gain bias, like the AD8362. It is convenient to select a VGA needing only a single 5 V supply and capable of generating a fully balanced differential output. All of these conditions are met by the AD8330. Figure 61 shows the schematic. The signal can be applied to the AD8330 in either single-ended or differential form by using a variety of coupling arrangements (see the [AD8330](#) data sheet for more information).

The basic gain of the AD8330 varies from 0 dB to 50 dB. Here it is raised 8 dB by driving VMAG from the 1.25 V available from the AD8362, whose 200  $\Omega$  loading on the 150  $\Omega$   $R_{OUT}$  of the AD8330 in turn lowers the overall gain by 5 dB. The peak gain is thus ~53 dB. (Mismatches between the on-chip resistors in each IC can cause a gain error of up to 1.3 dB.)

Using the AD8330's inverse gain mode (MODE pin low), its gain decreases on a slope of 30 mV/dB to a minimum value of 3 dB for a gain voltage (VDBS) of 1.5 V. VDDBS is 40% of the AD8362's output. Over the 3 V range from 0.5 V to 3.5 V, the gain of the AD8330 varies by  $(0.4 \times 3 \text{ V}) / (30 \text{ mV/dB})$ , that is, 40 dB. Combined with the 60 dB gain span of the AD8362, this results in a 100 dB variation for a 3 V change in VOUT. The overall log slope is therefore 30 mV/dB.

The full gain noise-spectral density at the AD8330's input is 5 nV/ $\sqrt{\text{Hz}}$  which is raised (by 53 dB) to 2.2 mV/ $\sqrt{\text{Hz}}$  at its output. To realize the full 100 dB potential, the noise at the AD8362's input must be much less than 1 mV rms. This requires limiting the AD8330's noise bandwidth to ~100 kHz (when  $e_N = 0.7 \text{ mV rms}$ ) provided by a single-pole, low-pass section at the coupling interface, formed by CFLT = 18 nF and the net differential resistance of 86  $\Omega$  (that is, 150  $\Omega \parallel 200 \Omega$ ).

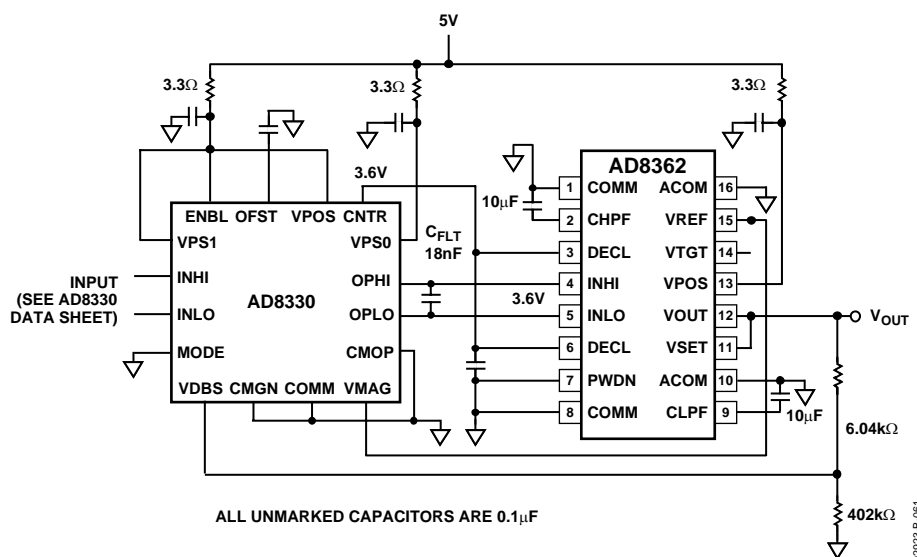

Figure 61. RMS Voltmeter with >100 dB Dynamic Range



# AD8362

If optimized for use at lower frequencies, CFLT should be increased accordingly; for audio applications, use 0.1  $\mu\text{F}$ . In RF measurements where the carrier frequency is known, the coupling and bandwidth limiting between the ICs might be provided by a narrow-band SAW filter. Figure 62 shows the output and law conformance error for this AD8330/AD8362 collaboration. The dynamic range extends from 5  $\mu\text{V}$  to 0.5 V rms between the 0.5 dB error points in this simulation.

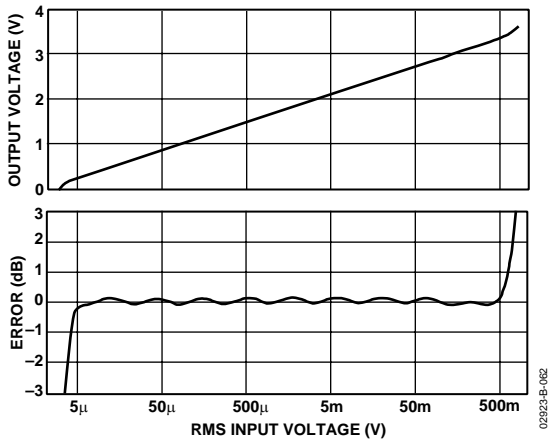

Figure 62. Output and Conformance for the AD8330/AD8362 Collaboration

## RF POWER METER WITH 80 DB RANGE

According to simulations, the basic 60 dB measurement range of the AD8362 can be extended by up to 20 dB by using a target voltage, VTGT, that increases progressively with the input level. In the simplest case, this can be achieved by connecting VTGT to the output VOUT/VSET. Figure 63 shows the connections; for present purposes, R1 is omitted and R2 is short-circuited.

For small signal inputs, VOUT is also small, and the target is well below the normal 75 mV (with 1.25 V applied to VTGT). The lower target means that the AD8362's VGA output does not have to be as large as normal, which increases the input sensitivity. As the signal and thus VOUT increases, so does the target voltage, which progressively shifts the required VGA input to a higher level.

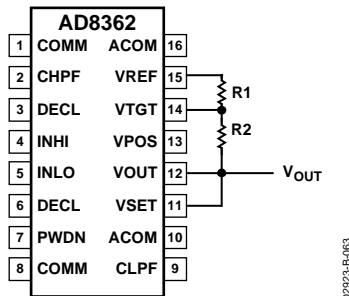

Figure 63. RF Power Meter with 80 dB Range

For example, a 10:1 change of VTGT from 0.35 V to 3.5 V shifts the intercept by 20 dB. This has the effect of stretching the measurement range by the same amount, from >60 dB to more than 80 dB. So the slope decreases to about 40 mV/dB because a larger input range is now represented by the same 3.15 V. The simulation results shown in Figure 64 compare the expanded range response with that for a fixed VTGT. The upper end of the measurement range is extended from 1.5 V to over 4 V (limited by the input protection).

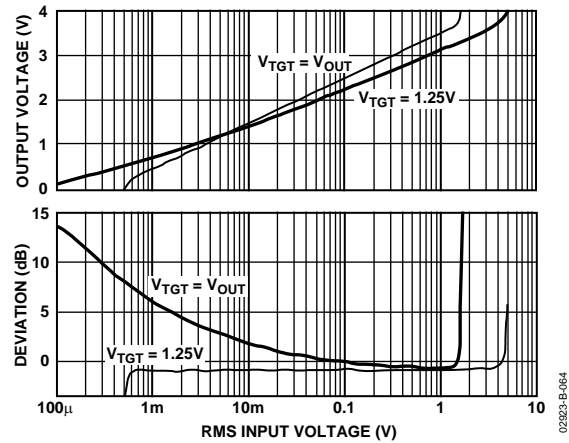

Figure 64. Dynamic Range Expansion Using VTGT = VOUT

However, it is apparent that the transfer function is no longer a simple logarithmic law; further consideration shows that the modified function is nonanalytic. Nevertheless, this function is dependable, and it remains as stable over supply and temperature variations as in the normal mode. A good approximation is provided by

$$V_{OUT} = V_{SLP'} \left\{ \log_{10} \left( \frac{V_{IN}}{V_Z} \right) - 11.3m \left[ \log_{10} \left( \frac{V_{IN}}{V_Z} \right) \right]^3 \right\} \quad (16)$$

where the modified slope voltage  $V_{SLP'}$  is 0.868 V, that is, 43.4 mV/dB. Using this expression, the dynamic range is 86 dB to the  $\pm 0.5$  dB error points ( $0.2 \text{ mV} \leq V_{IN} \leq 4 \text{ V}$ ). The actual range is reduced in practice by the effects of the AD8362's input-referred noise at low inputs. If the basic 60 dB+ range is only slightly less than required in a particular application, then a fraction of VOUT can be summed with a part of VREF to the VTGT pin, which is why R1 and R2 were included. The output now conforms in general terms to the formula

$$V_{OUT} = V_{SLP'} \left\{ \log_{10} \left( \frac{V_{IN}}{V_Z'} \right) - K_C \left[ \log_{10} \left( \frac{V_{IN}}{V_Z'} \right) \right]^3 \right\} \quad (17)$$

where the correction factor  $K_C$  introduces the required nonlinear correction to minimize the law-conformance error. Table 5 provides several representative spot values using progressively greater amounts of dynamic range extension.



Table 5. Suggested Values for Use in Scheme of Figure 63

R1 (Ω)	R2 (Ω)	V <sub>SLP'</sub> (V/decade)	V <sub>Z'</sub> (mV)	K <sub>C</sub> (m)
O/C	S/C	0.868	0.334	11.3
1904	96	0.870	0.336	10.4
1346	654	0.890	0.333	6.5
872	1128	0.914	0.340	3.7
480	1520	0.942	0.355	1.5
200	1800	0.972	0.380	0.5

### HIGH SLOPE DETECTORS CENTERED ON A NARROW WINDOW

The situation often arises in system monitoring in which an input signal varies by much less than 60 dB, and the highest possible sensitivity and accuracy of measurement is required within a narrow window of input magnitudes. Adapting the AD8362 to this task requires that the slope be increased and the intercept repositioned. Using an attenuator from VOUT to VSET, any slope >50 mV/dB can be realized. Then, using a fraction of VREF (or external reference voltage), the particular region of the dynamic range to be measured can be positioned wherever desired. In these high slope applications, the full rail-to-rail output swing of the AD8362 can be exploited.

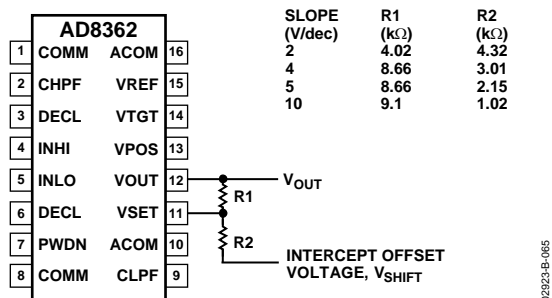

Figure 65. Slope and Intercept Adjustment

Figure 65 shows the basic connections for this mode of use; the intercept repositioning voltage V<sub>SHIFT</sub> can be introduced by adding a third resistor from VREF to VSET with recalculated values of R1 and R2 or by using an external voltage source. Figure 66 presents the simulation results for a log slope of 100 mV/dB (2 V/dec) covering two-decade spans over several sub-ranges, while Figure 67 shows the results for a slope of 200 mV/dB (4 V/dec), providing just a one-decade span.

To accurately reposition the range (intercept) when very high slopes are used, a low output impedance DAC can be used to provide V<sub>SHIFT</sub>. Figure 68 shows simulated results for a slope of 500 mV/dB (10 V/dec) presuming this configuration. In all cases, the fixed-pattern ripple in the log conformance remains unchanged in dB terms. Residual fluctuations due to insufficient averaging (in low frequency applications) are likewise unaffected in their equivalent decibel value, though greater in absolute voltage terms.

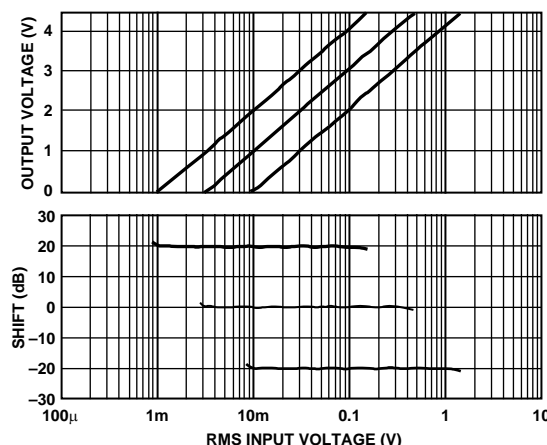

Figure 66. Illustrative Results for Slope of 100 mV/dB

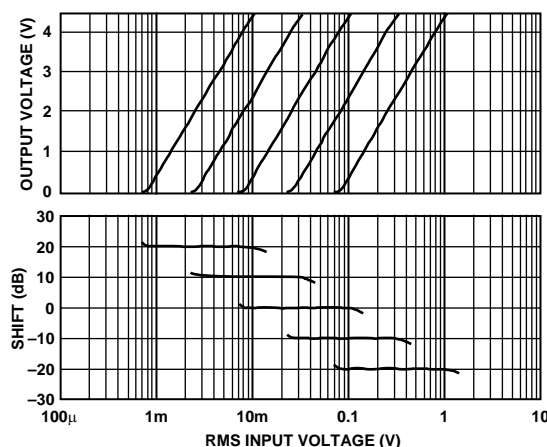

Figure 67. Illustrative Results for Slope of 200 mV/dB

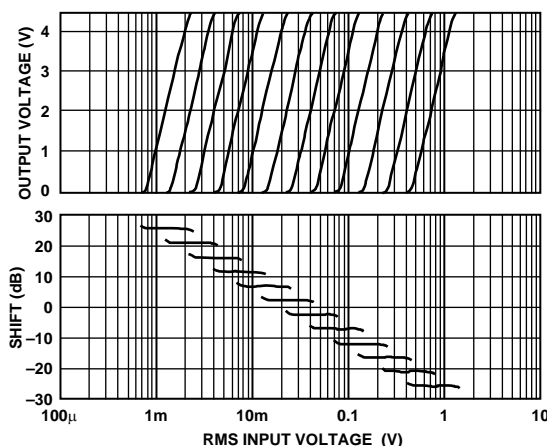

Figure 68. Illustrative Results for Slope of 10 mV/dec





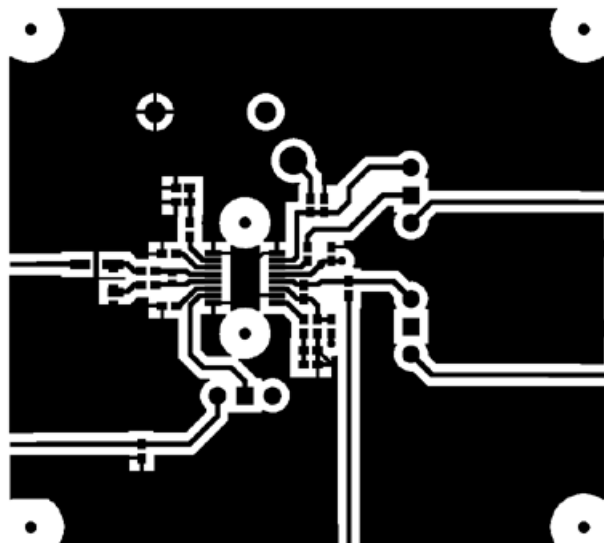

Figure 70. Component Side Metal of Evaluation Board

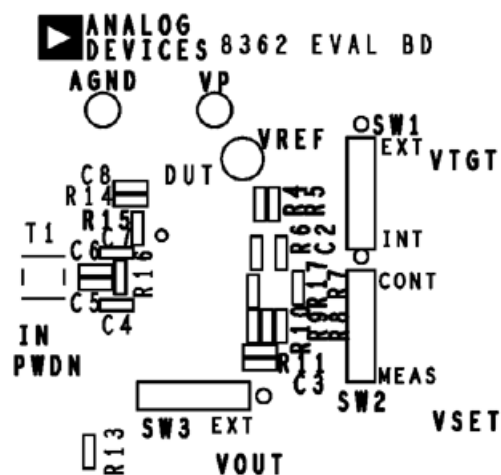

Figure 71. Component Side Silkscreen of Evaluation Board

Table 6. Evaluation Board Configuration Options

Component	Function	Part Number	Default Value
T1		M/A-COM ETC1.6-4-2-3	
C1	Supply filtering/decoupling capacitor		0.1 $\mu$ F
C2	Supply filtering/decoupling capacitor		100 pF
C3	Output low-pass filter capacitor		0.1 $\mu$ F
C9	Output low-pass filter capacitor (normally omitted, not installed)		
C4, C7, C10	Input bias-point decoupling capacitors		1000 pF
C5, C6	Input signal coupling capacitors		100 pF
C8	Input high-pass filter capacitor		1000 pF
DUT	AD8362	AD8362ARU	
R1, R4, R6, R7, R8, R10, R15	Jumpers		0 $\Omega$
R5, R9, R13	Optional pull-down resistors		10 k $\Omega$
R16	Not installed, see text		100 $\Omega$
R17	Slope adjustment (not installed, see text)		(See text)
RA	Not installed, see text		25 $\Omega$ or 0 $\Omega$
RB	Not installed, see text		33 $\Omega$
RC	Not installed, see text		0 $\Omega$
SW1	Internal/external target voltage selector		
SW2	Measurement mode/controller mode selector		
SW3	Power-down/enable or external power-down selector		



# AD8362

## OUTLINE DIMENSIONS

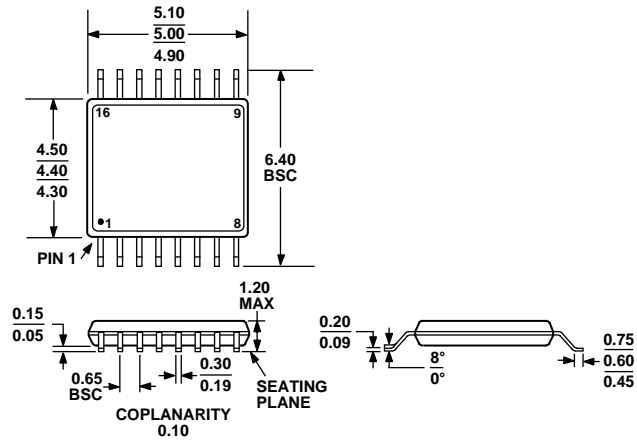

COMPLIANT TO JEDEC STANDARDS MO-153AB

Figure 72. 16-Lead Thin Shrink Small Outline Package [TSSOP]  
(RU-16)  
Dimensions shown in millimeters

## ORDERING GUIDE

Model	Temperature Range	Package Description	Package Option
AD8362ARU	-40°C to +85°C	16-Lead TSSOP, Tube	RU-16
AD8362ARU-REEL7	-40°C to +85°C	16-Lead TSSOP, 7" Tape and Reel	RU-16
AD8362ARUZ <sup>1</sup>	-40°C to +85°C	16-Lead TSSOP, Tube	RU-16
AD8362ARUZ-REEL7 <sup>1</sup>	-40°C to +85°C	16-Lead TSSOP, 7" Tape and Reel	RU-16
AD8362-EVAL		Evaluation Board	

<sup>1</sup> Z = Pb-free part.



**NOTES**



**AD8362**

**NOTES**

