

SIM508

HARDWARE SPECIFICATION

www.DataSheet4U.com

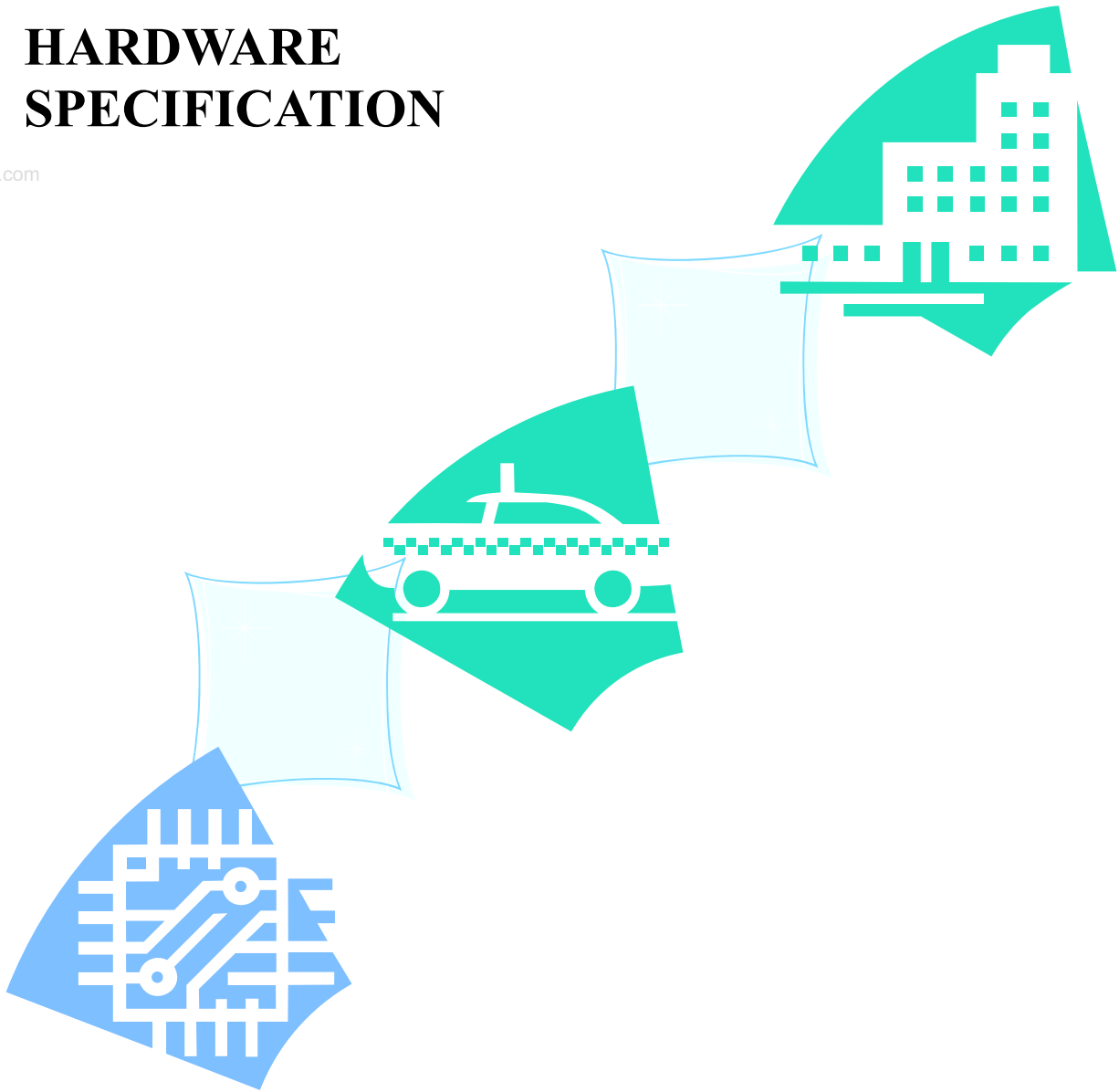

Designed by SIMCOM Ltd.,



9th Nov. 2006

Document Name:	SIM508 Hardware Interface Description
Version:	2.06
Date:	2006-11-9
Doc Id:	SIM508_HD_V2.06
Status:	Released

General Notes

Simcom offers this information as a service to its customers, to support application and engineering efforts that use Simcom products. The information provided is based upon requirements specifically provided to Simcom by the customers. Simcom has not undertaken any independent search for additional relevant information, including any information that may be in the customer's possession. Furthermore, system validation of this Simcom product within a larger electronic system remains the responsibility of the customer or the customer's system integrator. All specifications supplied herein are subject to change.

Copyright

This document contains proprietary technical information which is the property of SIMCOM Limited., copying of this document and giving it to others and the using or communication of the contents thereof, are forbidden without express authority. Offenders are liable to the payment of damages. All rights reserved in the event of grant of a patent or the registration of a utility model or design. All specification supplied herein are subject to change without notice at any time.

Copyright © SIMCOM Limited. 2006

Contents

Contents	3
Version History	7
1 Introduction	8
1.1 Related documents	8
1.2 Terms and abbreviations	9
2 Product concept	12
2.1 SIM508 key features at a glance	13
3 GSM application interface	15
3.1 Pin description	15
3.2 Operating modes	17
3.3 Power supply	19
3.3.1 Power supply pins on the board-to-board connector	20
3.3.2 Minimizing power losses	20
3.3.3 Monitoring power supply	20
3.4 Power up and down scenarios	20
3.4.1 Turn on the GSM part of SIM508	20
3.4.2 Turn off the GSM part of SIM508	23
3.4.3 Restart the GSM part of SIM508 using the PWRKEY pin	25
3.5 Charging interface	25
3.5.1 Battery pack characteristics	26
3.5.2 Recommended battery pack	26
3.5.3 Implemented charging technique	27
3.5.4 Operating modes during charging	28
3.5.5 Charger requirements	29
3.6 Power saving	29
3.6.1 Minimum functionality mode	30
3.6.2 SLEEP mode (slow clock mode)	30
3.6.3 Wake up the GSM part of SIM508 from SLEEP mode	30
3.7 Summary of state transitions (except SLEEP mode)	31
3.8 RTC backup	32
3.9 GSM Serial interface	35
3.9.1 Function of serial port & debug port supporting	36
3.9.2 Software upgrade and Software debug	37
3.10 Audio interfaces	38
3.10.1 Speaker interface configuration	39
3.10.2 Microphone interfaces configuration	40
3.10.3 Earphone interface configuration	40
3.10.4 Referenced electronic characteristic	41
3.11 SIM interface	41
3.11.1 SIM card application	41
3.11.2 Design considerations for SIM card holder	43
3.12 LCD interface	45
3.13 General purpose input & output(GPIO)	46

3.14 ADC	46
3.15 Behaviors of the RI line (serial port1 interface only).....	46
3.16 Network status indication LED lamp	48
3.17 Buzzer	48
4 GPS Application Interface	50
4.1 Theory of operation.....	50
4.2 Technical data.....	51
4.3 Pin description.....	52
4.4 Turn on the GPS part of SIM508	53
4.5 The theory of the GPS RTC circuit	54
4.6 The theory of the RESET Circuit	55
4.7 GPS operation modes.....	56
4.8 Serial interface of the SIM508 GPS part.....	56
4.9 Start-up procedure	57
4.9.1 Coldstart	57
4.9.2 Warmstart.....	57
4.9.3 Hotstart.....	57
5 Antenna interface	58
5.1 GSM Antenna.....	58
5.1.1 Antenna connector	58
5.1.2 Antenna pad	58
5.1.3 Module RF output power	60
5.1.4 Module RF receive sensitivity.....	60
5.1.5 Module operating frequencies.....	60
5.2 GPS Antenna	61
5.2.1 GPS Antenna Connection.....	61
5.2.2 GPS Antenna Choice Consideration	61
6 Electrical, reliability and radio characteristics	63
6.1 Absolute maximum ratings	63
6.2 Operating temperatures	63
6.3 Power supply rating.....	64
6.4 Current consumption	65
6.4.1 The current consumption of the SIM508 GSM part.....	65
6.4.2 The current consumption of the SIM508 GPS part.....	66
6.5 Electrostatic discharge.....	68
7 Mechanics	69
7.1 Mechanical dimensions of SIM508.....	69
7.2 Mounting SIM508 onto the application platform.....	70
7.3 Board-to-board connector	70
7.3.1 Mechanical dimensions of 54363-0878	70
7.3.2 Adapter cabling	72
7.3.3 PIN assignment of board-to-board connector of SIM508	73

Table index:

TABLE 1: RELATED DOCUMENTS	8
TABLE 2: TERMS AND ABBREVIATIONS	9
TABLE 3: SIM508 KEY FEATURES	13
TABLE 4: CODING SCHEMES AND MAXIMUM NET DATA RATES OVER AIR INTERFACE	14
TABLE 5: BOARD-TO-BOARD CONNECTOR PIN DESCRIPTION	15
TABLE 6: OVERVIEW OF OPERATING MODES	18
TABLE 7: AT COMMANDS USED IN ALARM MODE	22
TABLE 8: SPEC OF RECOMMENDED BATTERY PACK	27
TABLE 9: OPERATING MODES	28
TABLE 10: AT COMMAND USUALLY USED IN GHOST MODE	29
TABLE 11: SUMMARY OF STATE TRANSITIONS	31
TABLE 12: LOGIC LEVELS OF SERIAL PORTS PINS	35
TABLE 13: AUDIO INTERFACE SIGNAL	38
TABLE 14: MIC INPUT CHARACTERISTICS	41
TABLE 15: SPK OUTPUT CHARACTERISTICS	41
TABLE 16: BUZZER OUTPUT CHARACTERISTICS	41
TABLE 17: SIGNAL OF SIM INTERFACE (BOARD-TO-BOARD CONNECTOR)	42
TABLE 18: PIN DESCRIPTION (AMPHENOL SIM CARD HOLDER)	44
TABLE 19: PIN DESCRIPTION (MOLEX SIM CARD HOLDER)	45
TABLE 20: PIN DEFINE OF LCD INTERFACE	46
TABLE 21: GPIO OF THE GSM PART OF SIM508	46
TABLE 22: ADC PIN OF THE GSM PART OF SIM508	46
TABLE 23: BEHAVIOURS OF THE RI LINE	46
TABLE 24: WORKING STATE OF NETWORK STATUS INDICATION LED PIN	48
TABLE 25: PIN DESCRIPTION	52
TABLE 26: CONSOLIDATED PIN CHARACTERISTICS	53
TABLE 27: GPS OPERATION MODES	56
TABLE 28: THE GSM PART OF SIM508 CONDUCTED RF OUTPUT POWER	60
TABLE 29: THE GSM PART OF SIM508 CONDUCTED RF CONDUCTED RECEIVE SENSITIVITY	60
TABLE 30: THE GSM PART OF SIM508 OPERATING FREQUENCIES	60
TABLE 31: ABSOLUTE MAXIMUM RATINGS (GSM PART)	63
TABLE 32: ABSOLUTE MAXIMUM RATINGS (GPS PART)	63
TABLE 33: SIM508 OPERATING TEMPERATURE	63
TABLE 34: POWER SUPPLY RATING (GSM PART)	64
TABLE 35: POWER SUPPLY RATING (GPS PART)	65
TABLE 36: CURRENT CONSUMPTION (GSM PART)	65
TABLE 37: THE ESD ENDURE STATUE MEASURED TABLE (TEMPERATURE: 25°C, HUMIDITY: 45%)	68
TABLE 38: PIN ASSIGNMENT OF SIM 508	73

Figure Index

FIGURE 1: VBAT INPUT	19
FIGURE 2: VBAT VOLTAGE DROP AT THE MAXIMUM POWER TRANSMIT PHASE	19
FIGURE 3: TIMING OF TURN ON SYSTEM	21
FIGURE 4: TIMING OF TURN OFF SYSTEM	23
FIGURE 5: TIMING OF RESTART SYSTEM	25
FIGURE 6: BATTERY CHARGER AND PACK	26
FIGURE 7: RTC SUPPLY FROM NON-CHARGEABLE BATTERY	32
FIGURE 8: RTC SUPPLY FROM RECHARGEABLE BATTERY	32
FIGURE 9: RTC SUPPLY FROM CAPACITOR	33
FIGURE 10: PANASONIC EECEMOE204A CHARGE CHARACTERISTIC	33
FIGURE 11: MAXELL TC614 CHARGE CHARACTERISTIC	34
FIGURE 12: SEIKO TS621 CHARGE CHARACTERISTIC	34
FIGURE 13: INTERFACE OF SERIAL PORTS	35
FIGURE 14: INTERFACE OF SOFTWARE UPGRADE&DEBUG	37
FIGURE 15: SPEAKER INTERFACE CONFIGURATION	39
FIGURE 16: SPEAKER INTERFACE WITH AMPLIFIER CONFIGURATION	39
FIGURE 17: MICROPHONE INTERFACE CONFIGURATION	40
FIGURE 18: EARPHONE INTERFACE CONFIGURATION	40
FIGURE 19: SIM INTERFACE REFERENCE CIRCUIT WITH 8PIN SIM CARD	42
FIGURE 20: SIM INTERFACE REFERENCE CIRCUIT WITH 6PIN SIM CARD	43
FIGURE 21: AMPHENOL C707-10M006 512 2 SIM CARD HOLDER	44
FIGURE 22: MOLEX 91228 SIM CARD HOLDER	45
FIGURE 23: THE GSM PART OF SIM508 SERVICES AS RECEIVER	47
FIGURE 24: THE GSM PART OF SIM508 SERVICES AS CALLER	47
FIGURE 25: REFERENCE CIRCUIT FOR NETWORK STATUS LED	48
FIGURE 26: REFERENCE CIRCUIT FOR BUZZER	49
FIGURE 27: THEORY OF OPERATION	50
FIGURE 28: TURN ON THE GPS MODULE	54
FIGURE 29: THEORY OF THE GPS RTC CIRCUIT	55
FIGURE 30: THEORY OF THE RESET CIRCUIT	55
FIGURE 31: RF CONNECTOR AND RF PAD	59
FIGURE 32: RF CONNECTOR	61
FIGURE 33: POWER DOWN MODE	66
FIGURE 34: PUSH-TO-FIX MODE	67
FIGURE 35: POWER CONSUMPTION IN THE PTF MODE	68
FIGURE 36: SIM508 TOP VIEW AND SIDE VIEW	69
FIGURE 37: 54363-0878 BOARD-TO-BOARD CONNECTOR PIN SIDE	70
FIGURE 38: BOARD TO BOARD CONNECTOR PHYSICAL PHOTO	71
FIGURE 39: MM9329-2700B	72
FIGURE 40: RF CONNECTOR MXTK	72
FIGURE 41: PHYSICAL SIM508	74
FIGURE 42: REFERENCE CIRCUIT WITH EXTERNAL MCU (EXAMPLE APPLICATION)	75

Version History

Data	Version	Description of change	Author
2005-12-08	1.00	Origin	Simon
2006-02-28	1.01	<ol style="list-style-type: none"> 1. Modify figure 3, 4, 5, add "PWRKEY" 2. Modify figure 20, add "VEXT" and pull up resistor 3. Add "supporting Multiplexing" 4. Add "3.9.2 software upgrade and software debug" 5. Modify figure 28, 29, 36 6. Modify the description of "4.4 GPS Serial interface of the SIM508 GPS part" 	Ronald
2006-04-10	2.01	<ol style="list-style-type: none"> 1. Add the reference circuit of SIM508 2. Update autobauding 3. Modify figure 3, 4, 5 4. Add table 13, 17, 18, 25, 26, 27 5. Add figure 28, 29, 30, 31, 34, 35, 36, 43 6. Add "GPS Antenna Choice Consideration" 7. Add description of the GPS current consumption 	Ronald
2006-06-12	2.02	<ol style="list-style-type: none"> 1. Modify temperature range. 2. Update the figure of SIM card holder. 	Ronald
2006-06-20	2.03	<ol style="list-style-type: none"> 1. Modify temperature description of "3.4.2.4 2. Over-temperature automatic shutdown" 	William
2006-07-07	2.04	<ol style="list-style-type: none"> 1. Add the recommended GPS antenna vendors 2. Add details of SIM508 Mechanical dimensions 	William
2006-10-25	2.05	<ol style="list-style-type: none"> 1. Delete the chapter of antenna gain, 2. Modify the figure of the timing of turn on system, 3. Modify the figure of the timing of turn off system, 4. Modify the high voltage and low voltage of the PWRKEY. 5. Modify the PIN name. 	Ken
2006-11-09	2.06	<ol style="list-style-type: none"> 1. Modify audio output characteristics 2. Modify 80-pin connector name exactly 	Ken

1 Introduction

This document describes the hardware interface of the SIMCOM SIM508 module that connects to the specific application and the air interface. As SIM508 can be integrated with a wide range of applications, all functional components of SIM508 are described in great detail.

This document can help you quickly understand SIM508 interface specifications, electrical and mechanical details. With the help of this document and other SIM508 application notes, user guide, you can use SIM508 module to design and set-up mobile applications quickly.

www.DataSheet4U.com

1.1 Related documents

Table 1: Related documents

SN	Document name	Remark
[1]	SIM508_ATC	SIM508_ATC
[2]	ITU-T Draft new recommendation V.25ter:	Serial asynchronous automatic dialing and control
[3]	GSM 07.07:	Digital cellular telecommunications (Phase 2+); AT command set for GSM Mobile Equipment (ME)
[4]	GSM 07.05:	Digital cellular telecommunications (Phase 2+); Use of Data Terminal Equipment – Data Circuit terminating Equipment (DTE – DCE) interface for Short Message Service (SMS) and Cell Broadcast Service (CBS)
[5]	GSM 07.10:	Support GSM 07.10 multiplexing protocol
[6]	GSM 11.14:	Digital cellular telecommunications system (Phase 2+); Specification of the SIM Application Toolkit for the Subscriber Identity Module – Mobile Equipment (SIM – ME) interface
[7]	GSM 11.11:	Digital cellular telecommunications system (Phase 2+); Specification of the Subscriber Identity Module – Mobile Equipment (SIM – ME) interface
[8]	GSM 03.38:	Digital cellular telecommunications system (Phase 2+); Alphabets and language-specific information
[9]	GSM 11.10	Digital cellular telecommunications system (Phase 2) ; Mobile Station (MS) conformance specification; Part 1: Conformance specification

1.2 Terms and abbreviations

Table 2: Terms and abbreviations

GSM PART	
Abbreviation	Description
ADC	Analog-to-Digital Converter
ARP	Antenna Reference Point
ASIC	Application Specific Integrated Circuit
BER	Bit Error Rate
BTS	Base Transceiver Station
CHAP	Challenge Handshake Authentication Protocol
CS	Coding Scheme
CSD	Circuit Switched Data
CTS	Clear to Send
DAC	Digital-to-Analog Converter
DRX	Discontinuous Reception
DSP	Digital Signal Processor
DTE	Data Terminal Equipment (typically computer, terminal, printer)
DTR	Data Terminal Ready
DTX	Discontinuous Transmission
EFR	Enhanced Full Rate
EGSM	Enhanced GSM
EMC	Electromagnetic Compatibility
ESD	Electrostatic Discharge
ETS	European Telecommunication Standard
FCC	Federal Communications Commission (U.S.)
FDMA	Frequency Division Multiple Access
FR	Full Rate
GMSK	Gaussian Minimum Shift Keying
GPRS	General Packet Radio Service
GSM	Global Standard for Mobile Communications
HR	Half Rate
I/O	Input/Output
IC	Integrated Circuit
IMEI	International Mobile Equipment Identity
kbps	Kilo bits per second
LED	Light Emitting Diode
Li-Ion	Lithium-Ion
MO	Mobile Originated

MS	Mobile Station (GSM engine), also referred to as TE
MT	Mobile Terminated
PAP	Password Authentication Protocol
PBCCH	Packet Switched Broadcast Control Channel
PCB	Printed Circuit Board
PCS	Personal Communication System, also referred to as GSM 1900
PDU	Protocol Data Unit
PPP	Point-to-point protocol
RF	Radio Frequency
RMS	Root Mean Square (value)
RP	Receive Protocol
RTC	Real Time Clock
Rx	Receive Direction
SA	Selective Availability
SAR	Specific Absorption Rate
SIM	Subscriber Identification Module
SMS	Short Message Service
TDMA	Time Division Multiple Access
TE	Terminal Equipment, also referred to as DTE
TX	Transmit Direction
URC	Unsolicited Result Code
USSD	Unstructured Supplementary Service Data
VSWR	Voltage Standing Wave Ratio
Vmax	Maximum Voltage Value
Vnorm	Normal Voltage Value
Vmin	Minimum Voltage Value
VIHmax	Maximum Input High Level Voltage Value
VIHmin	Minimum Input High Level Voltage Value
VILmax	Maximum Input Low Level Voltage Value
VILmin	Minimum Input Low Level Voltage Value
VImax	Absolute Maximum Input Voltage Value
VImin	Absolute Minimum Input Voltage Value
VOHmax	Maximum Output High Level Voltage Value
VOHmin	Minimum Output High Level Voltage Value
VOLmax	Maximum Output Low Level Voltage Value
VOLmin	Minimum Output Low Level Voltage Value
<i>Phonebook abbreviations</i>	
FD	SIM fix dialing phonebook
LD	SIM last dialing phonebook (list of numbers most recently dialed)
MC	Mobile Equipment list of unanswered MT calls (missed calls)

ME	Mobile Equipment phonebook
RC	Mobile Equipment list of received calls
SM	SIM phonebook
DC	ME dialed calls list(+CPBW may not be applicable or this storage)(same as LD)
LA	Last Number All list (LND/LNM/LNR)
ON	SIM (or ME) own numbers (MSISDNs) list
SD	SIM service dial number
VM	SIM voice mailbox
BN	SIM barred dialed number

GPS PART

Abbreviation	Description
ATP	Adaptive Trickle Power mode.
DGPS	Differential GPS
GGA	GPS Fixed Data
GPS	Global Positioning System
LNA	Low Noise Amplifier
RTCM	Radio Technical Commission for Maritime Services

2 Product concept

Designed for global market, SIM508 is a Tri-band GSM/GPRS engine that works on frequencies GSM 900 MHz, DCS 1800 MHz and PCS1900 MHz and supports also GPS technology for satellite navigation. SIM508 provides GPRS multi-slot class10 / class 8 (option) capabilities and supports the GPRS coding schemes CS-1, CS-2, CS-3 and CS-4.

With a tiny configuration of 55mm x 34mm x 3.0 mm, SIM508 can fit almost all the space requirement in your application, such as Smart phone, PDA phone, GPS hand-held device and other mobile device, or applications of AVL (Automated Vehicle Location), location service and so on.

The physical interface to the mobile application is made through a 80 pins board-to-board connector, which provides all hardware interfaces between the module and customers' boards except the RF antenna interface.

- The keypad and SPI display interface will give you the flexibility to develop customized applications.
- One serial GSM port and two serial GPS pots can help you easily develop your applications.
- Two audio channels include two microphones inputs and two speaker outputs. This can be easily configured by AT command.
- Charge interface

With the charge circuit integrated inside the SIM508, it is very suitable for the battery power application.

SIM508 provide GSM RF antenna interface with two alternatives: antenna connector and antenna pad. The antenna connector is MURATA MM9329-2700. And customer's antenna can be soldered to the antenna pad. A separate GPS antenna must be connected to the GPS part of the module in order to properly receive satellite data.

The SIM508 is designed with power saving technique, the current consumption of GSM part maintains as low as about 3mA in SLEEP mode.

The SIM508 is integrated with the TCP/IP protocol, Extended TCP/IP AT commands are developed for customers to use the TCP/IP protocol easily, which is very useful for those data transfer applications.

2.1 SIM508 key features at a glance

Table 3: SIM508 key features

Feature	Implementation
Power supply	<ul style="list-style-type: none"> ● GSM part: Supply voltage 3.4V – 4.5V ● GPS part: Separate power supply source: 3.3V ± 5%
Power saving	<ul style="list-style-type: none"> ● GSM part: Typical power consumption in SLEEP mode to 2.5mA (BS-PA-MFRMS=5) ● GPS part: Power Down mode / Push-to-Fix mode
Charging	Supports charging control for Li-Ion battery
Frequency bands	<ul style="list-style-type: none"> ● SIM508 Tri-band: GSM 900, DCS 1800, PCS 1900. The band can be set by AT COMMAND, and default band is EGSM 900 and DCS 1800. ● Compliant to GSM Phase 2/2+
GSM class	Small MS
Transmit power	<ul style="list-style-type: none"> ● Class 4 (2W) at EGSM900 ● Class 1 (1W) at DCS1800 and PCS 1900
GPRS connectivity	<ul style="list-style-type: none"> ● GPRS multi-slot class 10 (default) ● GPRS multi-slot class 8 (option) ● GPRS mobile station class B
GPS features	<ul style="list-style-type: none"> ● GPS receiver with SiRFstar III GSC3f chip set ● Processor type ARM7/TDMI ● Software version: SiRF GSW3
Temperature range	<ul style="list-style-type: none"> ● Normal operation: -20°C to +55°C ● Restricted operation: -30°C to -20°C and +55°C to +80°C ● Storage temperature -40°C to +85°C
DATA GPRS:	<ul style="list-style-type: none"> ● GPRS data downlink transfer: max. 85.6 kbps ● GPRS data uplink transfer: max. 42.8 kbps ● Coding scheme: CS-1, CS-2, CS-3 and CS-4 ● SIM508 supports the protocols PAP (Password Authentication Protocol) usually used for PPP connections. ● The SIM508 integrates the TCP/IP protocol. ● Support Packet Switched Broadcast Control Channel (PBCCH)
CSD:	<ul style="list-style-type: none"> ● CSD transmission rates: 2.4, 4.8, 9.6, 14.4 kbps, non-transparent ● Unstructured Supplementary Services Data (USSD) support
SMS	<ul style="list-style-type: none"> ● MT, MO, CB, Text and PDU mode ● SMS storage: SIM card ● Support transmission of SMS alternatively over CSD or GPRS. User can choose preferred mode.
FAX	Group 3 Class 1
SIM interface	Support SIM card: 1.8V ,3V
External antenna	<ul style="list-style-type: none"> ● GSM part: Connected via 50 Ohm antenna connector or antenna pad

	<ul style="list-style-type: none"> ● GPS part: Separate GPS antenna connector. See Figure 33 for details
Audio features	<p>Speech codec modes:</p> <ul style="list-style-type: none"> ● Half Rate (ETS 06.20) ● Full Rate (ETS 06.10) ● Enhanced Full Rate (ETS 06.50 / 06.60 / 06.80) ● Echo suppression
Serial GSM interfaces and Debug interfaces	<ul style="list-style-type: none"> ● Serial port: Seven lines on Serial Port Interface ● Serial Port can be used for CSD FAX, GPRS service and send AT command of controlling module. ● Serial Port can use multiplexing function ● Autobauding supports baud rate from 1200 bps to 115200bps. ● Debug port: Two lines on debug Port, DBG_TXD and DBG_RXD ● Debug Port only used for debugging
Two serial GPS interfaces	<ul style="list-style-type: none"> ● Serial Port A: Two lines on Serial Port A, GPS_TXA and GPS_RXA ● Serial Port B: Two lines on Serial Port B, GPS_TXB and GPS_RXB
Phonebook management	Support phonebook types: SM, FD, LD, MC, RC, ON, ME, BN, VM, LA, DC, SD
SIM Application Toolkit	Support SAT class 3, GSM 11.14 Release 98
Real time clock	Implemented
Timer function	Programmable via AT command
Physical characteristics	<p>Size: 55±0.15 x 34±0.15 x 3.3±0.3 mm (including application connector)</p> <p>55±0.15 x 34±0.15 x 2.9±0.3 mm (excluding application connector)</p> <p>Weight: 11g</p>
Firmware upgrade	Firmware upgrade over serial interface

Table 4: Coding schemes and maximum net data rates over air interface

Coding scheme	1 Timeslot	2 Timeslot	4 Timeslot
CS-1:	9.05kbps	18.1kbps	36.2kbps
CS-2:	13.4kbps	26.8kbps	53.6kbps
CS-3:	15.6kbps	31.2kbps	62.4kbps
CS-4:	21.4kbps	42.8kbps	85.6kbps

3 GSM application interface

All hardware interfaces except RF interface that connects SIM508 to the customers' cellular application platform is through an 80-pin 0.5mm pitch board-to-board connector. Sub-interfaces included in this board-to-board connector are described in detail in following chapters:

- Power supply and charging control (*see Chapters 3.3 and 3.5*)
- GSM serial interface (*see Chapter 3.9*)
- Two analog audio interfaces (*see Chapter 3.10*)
- SIM interface (*see Chapter 3.11*)

www.DataSheet4U.com

Electrical and mechanical characteristics of the board-to-board connector are specified in *Chapter 6*. There we also ordering information for mating connectors.

3.1 Pin description

Table 5: Board-to-Board connector pin description

Power Supply			
PIN NAME	I/O	DESCRIPTION	DC CHARACTERISTICS
VBAT		Five BAT pins of the board-to-board connector are dedicated to connect the supply voltage. The power supply of the GSM part of SIM508 has to be a single voltage source of VBAT=3.4V..4.5V. It must be able to provide sufficient current in a transmit burst which typically rises to 2A. mostly, these 5 pins are voltage input	Vmax= 4.5V Vmin=3.4V Vnorm=4.0V
VRTC	I/O	RTC current input from the backup battery when the VBAT is not supplied for the system. Current output to backup battery when the main battery is present and the backup battery is low voltage state.	Vmax=2.0V Vmin=1.2V Vnorm=1.8V Inorm= 20uA
VCHG	I	Voltage input for the charge circuit; making the system detect the charger.	Vmax=5.25V Vmin=1.1 * VBAT Vnorm=5.1V
GND		Digital ground	
Power on or power off			
PIN NAME	I/O	DESCRIPTION	DC CHARACTERISTICS
PWRKEY	I	Voltage input for power on key. PWRKEY get a low level Voltage for	VILmax=0.2*VBAT VIHmin=0.6*VBAT

		user to power on or power off the system. The user should keep pressing the key for a moment when power on or power off the system. Because the system need margin time assert the software.	V _I max=VBAT
Audio interface			
PIN NAME	I/O	DESCRIPTION	DC CHARACTERISTICS
MIC1P MIC1N	I	Positive and negative voice-band input	Audio DC Characteristics refer to chapter 3.9.4
MIC2P MIC2N	I	Auxiliary positive and negative voice-band input	
SPK1P SPK1N	O	Positive and negative voice-band output	
SPK2P SPK2N	O	Auxiliary positive and negative voice-band output	
BUZZER	O	Buzzer Output	
AGND		Analog ground	
Display interface			
DISP_DATA	I/O	Display data line	V _{IL} min=0V
DISP_CLK	O	Display clock output	V _{IL} max=0.9
DISP_D/C	O	Display data or address select	V _{IH} min=2.0
DISP_CS	O	Display enable output	V _{IH} max= 3.2
DISP_RST	O	Display reset outplay	V _{OL} min=GND
			V _{OL} max=0.2V
			V _{OH} min=2.7
			V _{OH} max=2.9
Keypad interface			
KBC0~KBC4	O	Keypad array interface	V _{IL} min=0V
KBR0~KBR4	I		V _{IL} max=0.9
			V _{IH} min=2.0
			V _{IH} max= 3.2
			V _{OL} min=GND
			V _{OL} max=0.2V
			V _{OH} min=2.7
			V _{OH} max=2.9
GERNERAL PURPOSE input/output			
PIN NAME	I/O	DESCRIPTION	DC CHARACTERISTICS
NETLIGHT	O	GSM net indicator	V _{IL} min=0V
STATUS	O	Another indication for system on/off	V _{IL} max=0.9
GPI00	I/O	General purpose Input/Output port	V _{IH} min=2.0
GPI01	I/O	General purpose Input/Output port	V _{IH} max= 3.2
			V _{OL} min=GND

			VOLmax=0.2V VOHmin=2.7 VOHmax=2.9
Serial interface			
PIN NAME	I/O	DESCRIPTION	DC CHARACTERISTICS
DTR	I	Data Terminal Ready	VILmin=0V
RXD	I	Receive Data	VILmax=0.9
TXD	O	Transmit Data	VIHmin=2.0
RTS	I	Request to Send	VIHmax= 3.2
CTS	O	Clear to Send	VOLmin=GND
RI	O	Ring Indicator	VOLmax=0.2V
DCD	O	Data Carrier detection	VOHmin=2.7 VOHmax=2.9
Debug interface			
DBG_TXD	O	Serial interface for debugging and communication by AT command	
DBG_RXD	I		
SIM interface			
PIN NAME	I/O	DESCRIPTION	DC CHARACTERISTICS
SIM_VDD	O	Voltage Supply for SIM card	The voltage can be select by software either 1.8v or 2.85V
SIM_DATA	I/O	SIM Data Output	VILmin=0V
SIM_CLK	O	SIM Clock	VILmax=0.3* VSIM VIHmin=0.7* VSIM
SIM_PRESENCE	I	SIM Card Detection	VIHmax= VSIM +0.3
SIM_RST	O	SIM Reset	VOLmin=GND VOLmax=0.2V VOHmin= VSIM -0.2 VOHmax= VSIM
AUXADC			
PIN NAME	I/O	DESCRIPTION	DC CHARACTERISTICS
ADC0	I	General purpose analog to digital converter.	Input voltage value scope 0V to 2.4V
TEMP_BAT	I	For measure the battery temperature	

3.2 Operating modes

The following table summarizes the various operating modes, each operating modes is referred to in the following chapters.

Table 6: Overview of operating modes

Mode	Function	
Normal operation	GSM/GPRS SLEEP	Module will automatically go into SLEEP mode if DTR is set to high level and there is no on air or audio activity is required and no hardware interrupt (such as GPIO interrupt or data on serial port). In this case, the current consumption of module will reduce to the minimal level. During sleep mode, the module can still receive paging message and SMS from the system normally.
	GSM IDLE	Software is active. Module has registered to the GSM network, and the module is ready to send and receive.
	GSM TALK	CSD connection is going on between two subscribers. In this case, the power consumption depends on network settings such as DTX off/on, FR/EFR/HR, hopping sequences, antenna.
	GPRS IDLE	Module is ready for GPRS data transfer, but no data is currently sent or received. In this case, power consumption depends on network settings and GPRS configuration (e.g. multi-slot settings).
	GPRS DATA	There is GPRS data in transfer (PPP or TCP or UDP). In this case, power consumption is related with network settings (e.g. power control level), uplink / downlink data rates and GPRS configuration (e.g. used multi-slot settings).
	POWER DOWN	Normal shutdown by sending the “AT+CPOWD” command or using the PWRKEY. The power management ASIC disconnects the power supply from the base band part of the module, only the power supply for the RTC is remained. Software is not active. The serial interfaces are not accessible. Operating voltage (connected to VBAT) remains applied.
Minimum functionality mode (without remove power supply)	Use the “AT+CFUN” command can set the module to a minimum functionality mode without remove the power supply. In this case, the RF part of the module will not work and the SIM card will not be accessible. Although RF part and SIM card will be closed all, the serial interface is still accessible. The power consumption in this case is very low.	
Alarm mode	RTC alert function launches this restricted operation while the module is in POWER DOWN mode. SIM508 will not be registered to GSM network and only parts of AT commands can be available.	
GHOST Mode (Charge-only mode)	GHOST mode means off and charging mode. In this mode, the module can not be registered to GSM network and only limited AT commands can be accessible, the following way will launch GHOST mode: <ul style="list-style-type: none"> ● From POWER DOWN mode: Connect charger to the module’s VCHG pin, and battery is present while SIM508 is power down. ● From Normal mode: Connect charger to the module’s VCHG pin, and battery is present, then power down the module by “AT+CPOWD=1” 	

Charge mode during normal operation	Start charging while the module is in normal mode (including: SLEEP, IDLE, TALK, GPRS IDLE and GPRS DATA)
-------------------------------------	---

3.3 Power supply

The power supply of SIM508 GSM part is from a single voltage source of VBAT= 3.4V...4.5V. In some case, the ripple in a transmit burst may cause voltage drops when current consumption rise to typical peaks of 2A. So the power supply must be able to provide sufficient current up to 2A.

For the VBAT input, a local bypass capacitor is recommended. A capacitor (about 100 μ F, low ESR) is recommended. Multi-layer ceramic chip (MLCC) capacitors can provide the best combination of low ESR and small size but may not be cost effective. A lower cost choice may be a 100 μ F tantalum capacitor (low ESR) with a small (0.1 μ F to 1 μ F) ceramic in parallel, which is illustrated as figure1. And the capacitors should put as closer as possible to the SIM508 VBAT pins.

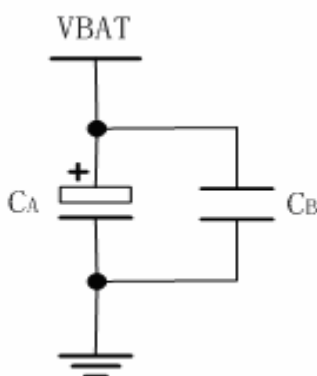

Figure 1: VBAT input

The following figure is the VBAT voltage ripple wave at the maximum power transmit phase, the test condition is VBAT=4.0V, VBAT maximum output current =2A, CA=100 μ F tantalum capacitor (ESR=0.7 Ω) and CB=1 μ F.



Figure 2: VBAT voltage drop at the maximum power transmit phase

3.3.1 Power supply pins on the board-to-board connector

Five VBAT pins of the board-to-board connector are dedicated to connect the supply voltage. The VCHG pin serves as control signal for charging a Li-Ion battery. VRTC pin can be used to back up the RTC.

3.3.2 Minimizing power losses

Please pay special attention to the supply power when you are designing your applications. Please make sure that the input voltage will never drop below 3.4V even in a transmit burst during which the current consumption may rise up to 2A. If the power voltage drops below 3.4V, the module may be switched off. So the impedance from external power supply to module VBAT pins should as low as possible. When using a battery, you should also take the impedance of the battery pack, the battery connector and PCB track on the host board into account.

3.3.3 Monitoring power supply

To monitor the supply voltage, you can use the “AT+CBC” command which include three parameters: charge state, voltage percent and voltage value (in mV). It returns charge state, the battery voltage 1-100 percent of capacity and actual value measured at VBAT and GND.

The voltage is continuously measured at intervals depending on the operating mode. The displayed voltage (in mV) is averaged over the last measuring period before the AT+CBC command was executed.

For details please refer to *document [1]*

3.4 Power up and down scenarios

3.4.1 Turn on the GSM part of SIM508

The GSM part of SIM508 can be turned on by various ways, which are described in following chapters:

- Via PWRKEY pin: starts normal operating mode (see chapter 3.4.1.1);
- Via VCHG pin: starts GHOST modes (see chapter 3.4.1.2);
- Via RTC interrupt: starts ALARM modes (see chapter 3.4.1.3)

Note: Only enter AT command through serial port after SIM508 is power on and Unsolicited Result Code “RDY” is received from serial port.

Note: If configured to a fix baud rate, SIM508 will send the result code “RDY” to indicate that it is ready to operate. This result code does not appear when autobauding is active. You can use AT+IPR=x;&W to set a fix baud rate and save the configuration to non-volatile flash memory. See Chapter AT+IPR in document [1].

3.4.1.1 Turn on the GSM part of SIM508 using the PWRKEY pin (Power on)

You can turn on the GSM part of SIM508 by driving the PWRKEY to a low level voltage for period time. The power on scenarios illustrate as the following figure.

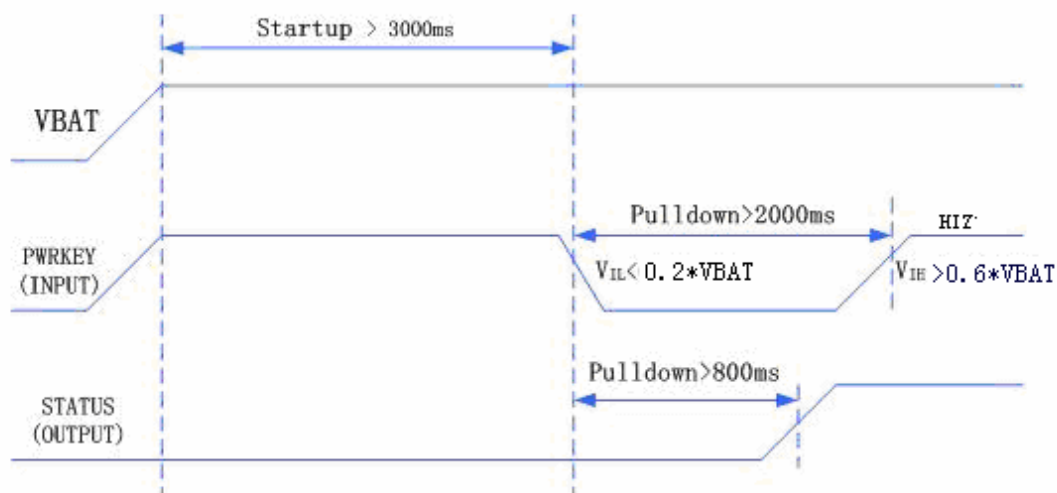

Figure 3: Timing of turn on system

When power on procedure complete, the GSM part of SIM508 will send out following result code to indicate the module is ready to operate, and STATUS pin will drive to 2.8V and keep this level when in work mode. Only set baud rate serial port can send out “RDY”, if set auto-baud rate serial port send nothing.

RDY

3.4.1.2 Turn on the GSM part of SIM508 using the VCHG signal

As described in chapter 3.5, charger can be connected to the GSM part of SIM508’s VCHG pin regardless of the module’s operating mode.

If the charger is connected to the module’s VCHG pin while the GSM part of SIM508 is in POWER DOWN mode, it will go into the GHOST mode (Off and charging). In this mode, the module will not register to network, and only a few AT commands can work in this mode. For detailed information please refers to chapter 3.5.4.

When module is powered on using the VCHG signal, the GSM part of SIM508 sends out result code as following when fixed baud rate:

RDY

GHOST MODE

+CFUN: 0

In GHOST mode, by driving the PWRKEY to a low level voltage for period time (Please refer to the power on scenarios in 3.4.1.1), the GSM part of SIM508 will power up and go into charge mode (charging in normal mode), all operation and AT commands can be available. In this case, the GSM part of SIM508 will send out result code as following:

From GHOST MODE to NORMAL MODE

3.4.1.3 Turn on the GSM part of SIM508 using the RTC (Alarm mode)

Alarm mode is a power-on approach by using the RTC. The alert function of RTC makes the GSM part of SIM508 wake up while the module is power off. In alarm mode, the GSM part of SIM508 will not register to GSM network and the software protocol stack is close. Thus the parts of AT commands related with SIM card and Protocol stack will not accessible, and the others can be used as well as in normal mode.

Use the AT+CALARM command to set the alarm time. The RTC remains the alarm time if the GSM part of SIM508 was power down by “AT+CPOWD=1” or by PWRKEY pin. Once the alarm time is expired and executed, the GSM part of SIM508 goes into the Alarm mode. In this case, the GSM part of SIM508 will send out an Unsolicited Result Code (URC):

RDY

ALARM MODE

During Alarm mode, use AT+CFUN command to query the status of software protocol stack; it will return 0 which indicates that the protocol stack is closed. Then after 90s, the GSM part of SIM508 will power down automatically. However, during Alarm mode, if the software protocol is started by AT+CFUN=1 command, the process of automatic power down will not be available. In ALARM mode, driving the PWRKEY to a low level voltage for a period will cause the GSM part of SIM508 to power down (Please refer to the power down scenarios).

The table follow briefly summarizes the AT commands that are used usually during alarm mode, for details of the instructions refer to *document [1]*:

Table 7: AT commands used in Alarm mode

AT command	USE
AT+CALARM	Set alarm time
AT+CCLK	Set data and time of RTC
AT+CPOWD	Power down
AT+CFUN	Start or close the protocol stack

3.4.2 Turn off the GSM part of SIM508

Following procedure can be used to turn off the GSM part of SIM508:

- Normal power down procedure: Turn off the GSM part of SIM508 using the PWRKEY pin (see chapter 3.4.2.1)
- Normal power down procedure: Turn off the GSM part of SIM508 using AT command (see chapter 3.4.2.2)
- Under-voltage Automatic shutdown: Take effect if under voltage is detected (see chapter 3.4.2.3)
- Over-temperature Automatic shutdown: Take effect if under voltage is detected (see chapter 3.4.2.4)

www.DataSheet4U.com

3.4.2.1 Turn off the GSM part of SIM508 using the PWRKEY pin (Power down)

You can turn off the GSM part of SIM508 by driving the PWRKEY to a low level voltage for period time. The power down scenarios illustrate as Figure4.

This procedure will let the module to log off from the network and allow the software to enter into a secure state and save data before completely disconnect the power supply.

Before the completion of the switching off procedure the module will send out result code:

NORMAL POWER DOWN

After this moment, the AT commands can't be executed. The module enters the POWER DOWN mode, only the RTC is still active. POWER DOWN can also be indicated by STATUS pin, which is a low level voltage in this mode.

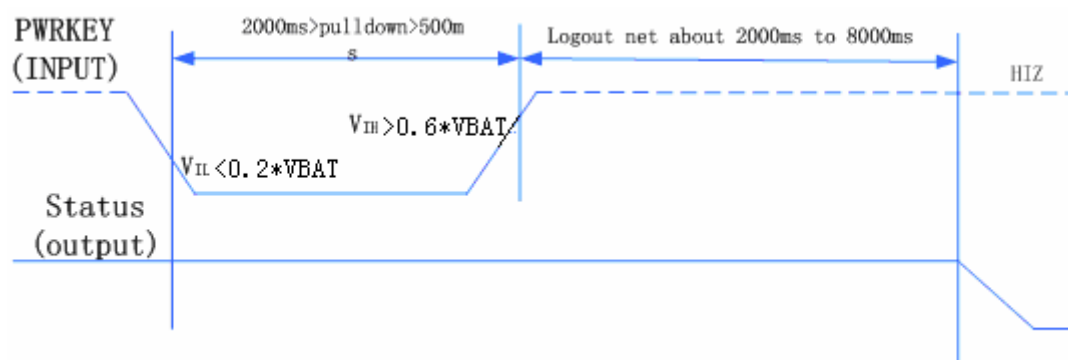

Figure 4: Timing of turn off system

3.4.2.2 Turn off the GSM part of SIM508 using AT command

You can use an AT command "AT+CPOWD=1" to turn off the module. This command will let the module to log off from the network and allow the software to enter into a secure state and save data before completely disconnect the power supply.

Before switching off, the module will send out result code:

NORMAL POWER DOWN

After this moment, the commands can't be executed. The module enters the POWER DOWN mode, only the RTC is still active. POWER DOWN can also be indicated by STATUS pin, which is a low level voltage in this mode.

Please refer to *document [1]* for detail about the AT command of "AT+CPOWD".

www.DataSheet4U.com

3.4.2.3 Under-voltage automatic shutdown

Software will constantly monitor the voltage applied on the VBAT, if the measured battery voltage is no more than 3.5V, the module will send out result code:

POWER LOW WARNING

If the measured battery voltage is no more than 3.4V, the following URC will be presented:

POWER LOW DOWN

After this moment, no further more AT commands can be executed. The module will log off from network and enters POWER DOWN mode, only the RTC is still active. POWER DOWN can also be indicated by STATUS pin, which is a low level voltage in this mode.

3.4.2.4 Over-temperature automatic shutdown

Software will constantly monitor the temperature of the module, if the measured temperature is equal or higher than 80°C, the following URC will be presented:

+CMTE:1

If the measured temperature $\leq -30^{\circ}\text{C}$, the following URC will be presented:

+CMTE:-1

The uncritical temperature range is -35°C to 85°C . If the measured temperature $\geq 85^{\circ}\text{C}$ or $\leq -35^{\circ}\text{C}$, the module will be automatic shutdown soon.

If the measured temperature $\geq 85^{\circ}\text{C}$, the following URC will be presented:

+CMTE:2

If the measured temperature $\leq -35^{\circ}\text{C}$, the following URC will be presented:

+CMTE:-2

After this moment, the AT commands can't be executed. The module will log off from network and enter POWER DOWN mode, only the RTC is still active. POWER DOWN can also be indicated

by STATUS pin, which is a low level voltage in this mode.

To monitor the temperature, you can use the “AT+CMTE” command to measure the temperature when the module is power on.

For details please refer to *document [1]*

3.4.3 Restart the GSM part of SIM508 using the PWRKEY pin

You can restart SIM508 by driving the PWRKEY to a low level voltage for period time, same as turn on SIM508 using the PWRKEY pin. Before restart the SIM508, you need delay at least 500ms from detecting the STATUS low level on. The restart scenarios illustrate as the following figure.

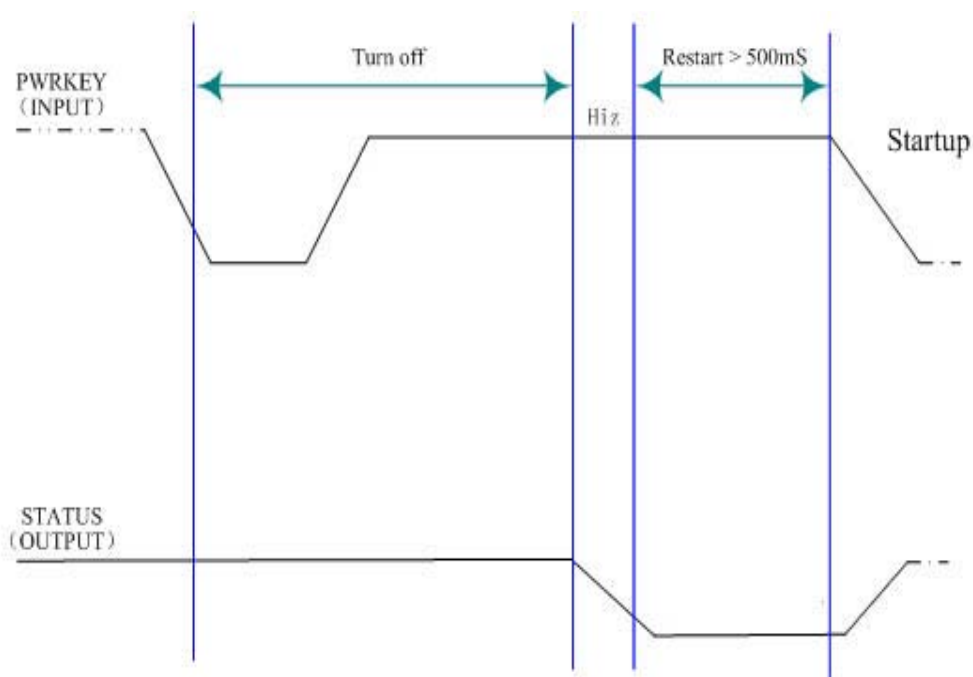

Figure 5: Timing of restart system

3.5 Charging interface

The GSM part of SIM508 has integrated a charging circuit inside the module for Li-Ion batteries charging control, which make it very convenient for applications to manage their battery charging. A common connection is shown in the following figure:

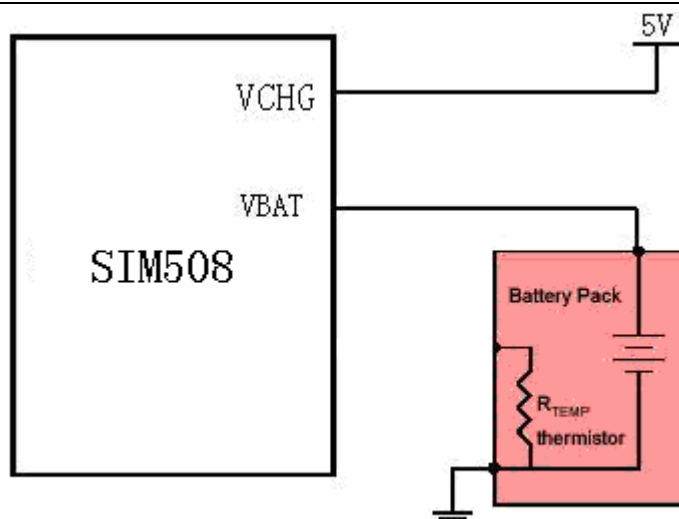

Figure 6: Battery charger and pack

3.5.1 Battery pack characteristics

The GSM part of SIM508 has optimized the charging algorithm for the Li-Ion battery that meets the characteristics listed below. To use the GSM part of SIM508's charging algorithm properly, it is recommended that the battery pack you integrated into your application is compliant with these specifications. The battery pack compliant with these specifications is also important for the AT command "AT+CBC" to monitor the voltage of battery, or the "AT+CBC" may return incorrect battery capacity values.

- The maximum charging voltage of the Li-Ion battery pack is 4.2V and the capacity is 580mAh. Battery packs with a capacity down to 580 mAh or more than 580 mAh are allowed, too.
- The pack should have a protection circuit to avoid overcharging, deep discharging and over-current. This circuit should be insensitive to pulsed current.
- On the GSM part of SIM508, the build-in circuit of the GSM part of SIM508's power management chipset monitors the supply voltage constantly. Once the Under-voltage is detected, the GSM part of SIM508 will power down automatically. Under-voltage thresholds are specific to the battery pack.
- The internal resistance of the battery and the protection circuit should be as low as possible. It is recommended not to exceed 200mΩ.
- The battery pack must be protected from reverse pole connection.

3.5.2 Recommended battery pack

Following is the spec of recommended battery pack:

Table 8: Spec of recommended battery pack

Product name & type	BYD, Li-Ion, 3.7V, 580mAh
To obtain more information Please contact :	BYD COMPANY LIMITED
Normal voltage	3.7V
Capacity	Minimum 580mAh
Charge Voltage	4.200±0.049V
Max Charge Current	1.5C
Charge Method	CC / CV (Constant Current / Constant Voltage)
Max Discharge Current	1.5C (for continuous discharging mode)
Discharge Cut-off Voltage	2.75V/ cell
Internal resistance	Initial ≤200mΩ After 400cycles ≤270mΩ

3.5.3 Implemented charging technique

The GSM part of SIM508 includes the function for battery charging. There are three pins in the connector related with the battery charging function: VCHG, VBAT and BAT_TEMP pins. The VCHG pin is driven by an external voltage, system can use this pin to detect a charger supply and provide most charging current through the GSM part of SIM508 module to battery when charging is in fast charge state. The VBAT give out charging current from the GSM part of SIM508 module to external battery. BAT_TEMP pin is for user to measure the battery temperature. Just let this pin open if battery temperature measuring is not your concern.

So it is very simple to implement charging technique, you need only connect the charger to the VCHG pin and connect the battery to the VBAT pin.

The GSM part of SIM508 detect charger supply and the battery is present, battery charging will happen. If there is no charger supply or no battery present the charging will not be enabled.

Normally, there are three main states in whole charging procedure.

- DDLO charge and UVLO charge;
- Fast charge;
- Trickle charge;

DDLO charge and UVLO charge:

DDLO (deep discharge lock out) is the state of battery when its voltage under 2.4V. And UVLO (under voltage lock out) means the battery voltage less than 3.2V and more than 2.4V. The battery is not suitable for fast charge when its condition is DDLO or UVLO. The GSM part of SIM508 provides a small constant current to the battery when the battery is between DDLO and UVLO. In DDLO charge, The GSM part of SIM508 gives out 5mA current to the battery. And in UVLO charge, The GSM part of SIM508 provide about 25mA current to the battery.

DDLO charge terminated when the battery voltage reaches 2.4V. UVLO charge terminated when the battery voltage is up to 3.2V. Both DDLO and UVLO charge are controlled by the GSM part of SIM508 hardware only.

Fast charge:

If there is a charger supply and battery present and the battery is not in DDLO and UVLO, the GSM part of SIM508 will enter fast charge state. Fast charge controlled by the software. Fast charge delivers a strong and constant current (about 450mA) through VBAT pin to the battery until battery voltage reach 4.2V.

www.DataSheet4U.com

Trickle charge:

After fast charging, the battery voltage near the whole battery capacity, trick charge begins .in this state, the GSM part of SIM508 charge the battery under constant voltage.

3.5.4 Operating modes during charging

The battery can be charged during various operating mode. That means that when the GSM engine is in Normal mode (SLEEP, IDLE, TALK, GPRS IDLE or GPRS DATA mode), charging can be in progress while the GSM part of SIM508 remains operational (In this case the voltage supply should be sufficient). Here we name Charging in Normal mode as Charge mode.

If the charger is connected to the module’s VCHG pin and the battery is connected to the VBAT pin while the GSM part of SIM508 is in POWER DOWN mode, the GSM part of SIM508 will go into the GHOST mode (Off and charging). The following table gives the difference between Charge mode and GHOST mode:

Table 9: operating modes

	How to activate mode	Features
Charge Mode	Connect charger to module’s VCHG pin and connect battery to VBAT pin of module while the GSM part of SIM508 is in Normal operating mode, including: IDLE, TALK mode; SLEEP mode etc;	<ul style="list-style-type: none"> ● GSM remains operational and registered GSM network while charging is in progress; ● The serial interfaces are available in IDLE, TALK mode, the AT command set can be used fully in this case; <p>In SLEEP mode, the serial interfaces are not available, once the serial port is connected and there is data in transfer. Then the GSM part of SIM508 will exit the SLEEP mode.</p>

GHOST Mode	<p>Connect charger to module's VCHG pin while the GSM part of SIM508 is in POWER DOWN mode.</p> <p>IMPORTANT: In GHOST mode not all the software tasks are running.</p>	<ul style="list-style-type: none"> ● Battery can be charged when GSM engine is not registered to GSM network; ● Only a few AT commands is available as listed below.
-------------------	---	--

Note:

VBAT can not provide much more than 5mA current while sim508 module is during the DDLO charge state. In other words it is strongly recommended that VBAT should not be the main power supply in the application subsystem while sim508 module is during the DDLO charge state.

Table 10: AT Command usually used in GHOST mode

AT command	Function
AT+CALARM	Set alarm time
AT+CCLK	Set data and time of RTC
AT+CPOWD	Power down
AT+CBC	Indicated charge state and voltage
AT+CFUN	Start or close the protocol Set AT command“ AT+CFUN =1”,module can be transferred from GHOST mode to Charging in normal mode, In GHOST mode , the default value is

3.5.5 Charger requirements

Following is the requirements of charger for the GSM part of SIM508.

a) Simple transformer power plug

- Output voltage: 5.0V-5.25V
- Charging current limitation: 650mA
- A 10V peak voltage is allowed for maximum 1ms when charging current is switched off.
- A 1.6A peak current is allowed for maximum 1ms when charging current is switched on.

3.6 Power saving

There are two methods to achieve the GSM part of SIM508 module extreme low power. “AT+CFUN” is used to set module into minimum functionality mode and DTR hardware interface signal can be used to set system to be SLEEP mode (or slow clocking mode).

3.6.1 Minimum functionality mode

Minimum functionality mode reduces the functionality of the module to a minimum and, thus, minimizes the current consumption to the lowest level. This mode is set with the “AT+CFUN” command which provides the choice of the functionality levels <fun>=0, 1, 4

- 0: minimum functionality;
- 1: full functionality (Default);
- 4: disable phone both transmit and receive RF circuits;

www.DataSheet4U.com

If the GSM part of SIM508 has been set to minimum functionality by “AT+CFUN=0”, then the RF function and SIM card function will be closed, in this case, the serial port is still accessible, but all AT commands need RF function or SIM card function will not be accessible.

If the GSM part of SIM508 has disable all RF function by “AT+CFUN=4”, then RF function will be closed, the serial port is still active in this case but all AT commands need RF function will not accessible.

When the GSM part of SIM508 is in minimum functionality or has been disable all RF functionality by “AT+CFUN=4”, it can return to full functionality by “AT+CFUN=1”.

For detailed information about “AT+CFUN”, please refer to document[1].

3.6.2 SLEEP mode (slow clock mode)

You can use DTR signal to control the GSM part of SIM508 module to enter or exit the SLEEP mode in your applications.

When DTR is in high level, at the same time there is no on air or audio activity is required and no hardware interrupt (such as GPIO interrupt or data on serial port), the GSM part of SIM508 will enter SLEEP mode automatically. In this mode, the GSM part of SIM508 can still receive paging or SMS from network.

In SLEEP mode, the serial port is not accessible.

Note: For some special software versions, it requests to set AT command “AT+CSCLK=1” to enable the sleep mode; the default value is 0, that can't make the module enter sleep mode, for more details please refer to the AT command list.

3.6.3 Wake up the GSM part of SIM508 from SLEEP mode

When the GSM part of SIM508 is SLEEP mode, the following method can wake up the module.

- Enable DTR pin to wake up the GSM part of SIM508
If DTR Pin is pull down to a low level, this signal will wake up the GSM part of SIM508 from power saving mode. The serial port will be active after DTR change to low level about 3ms.

- Receive a voice or data call from network to wake up the GSM part of SIM508
- Receive a SMS from network to wake up the GSM part of SIM508
- RTC alarm expired to wake up the GSM part of SIM508

3.7 Summary of state transitions (except SLEEP mode)

Table 11: Summary of state transitions

Further mode	POWER DOWN	Normal mode	Ghost mode (Charge-only mode)	Charging in normal	Alarm mode
Current mode					
POWER DOWN		Use PWRKEY	Connect charger to VCHG and connect battery to VBAT	No direct transition, but via “Ghost mode” or “Normal mode”	Switch on from POWER DOWN mode by RTC
Normal mode	AT+CPOWD or use PWRKEY pin		Connect charger to VCHG and connect battery to VBAT, then switch off module by AT+CPOWD or using PWRKEY	Connect charger to VCHG pin of module and connect battery to VBAT pin of module	Set alarm by “AT+CALARM”, and then switch off the module. When the timer expire, the module turn on and enter Alarm mode
Ghost mode (Charge-only mode)	Disconnect charger	No direct transition, but via “Charging in normal” mode		Turn on the module using PWRKEY OR SET AT Command “AT+CFUN=1”	Set alarm by “AT+CALARM”, when the timer expire, module will enter Alarm mode
Charging in normal	AT+CPOWD → “Ghost mode”, then disconnect charger	Disconnect the charger	Switch off module by AT+CPOWD or using PWRKEY		No direct transition
Alarm mode	Use PWRKEY pin or wait module switch off automatically	Use AT+CFUN	No transition	Use AT+CFUN let module enter Normal mode, then connect the charger to VCHG pin of module	

3.8 RTC backup

The RTC (Real Time Clock) power supply of module can be provided by an external battery or a battery (rechargeable or non-chargeable) through PIN 14 on the board-to-board connector. There is a 10K resistance has been integrated in the GSM part of SIM508 module used for restricting current. You need only a coin-cell battery or a super-cap to PIN 14 to backup power supply for RTC.

Note: The VRTC couldn't be designed to a NC pin in your circuit. You should connect the VRTC pin to a battery or a capacitor.

The following figures show various sample circuits for RTC backup.

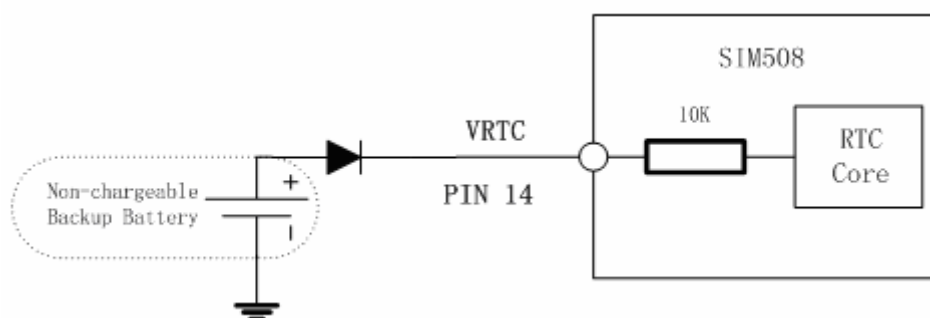

Figure 7: RTC supply from non-chargeable battery

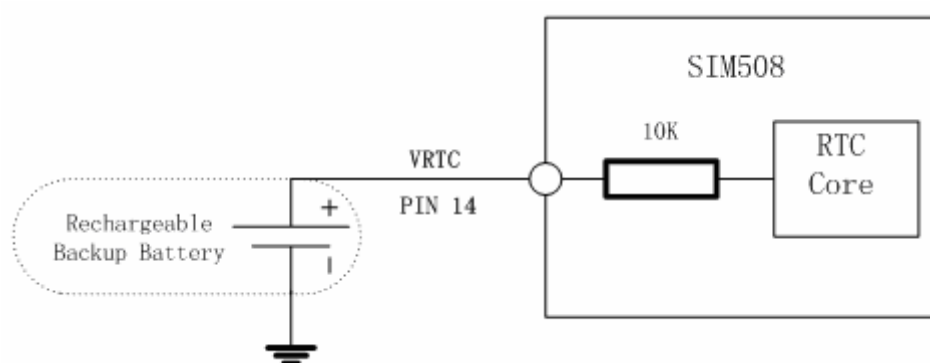

Figure 8: RTC supply from rechargeable battery

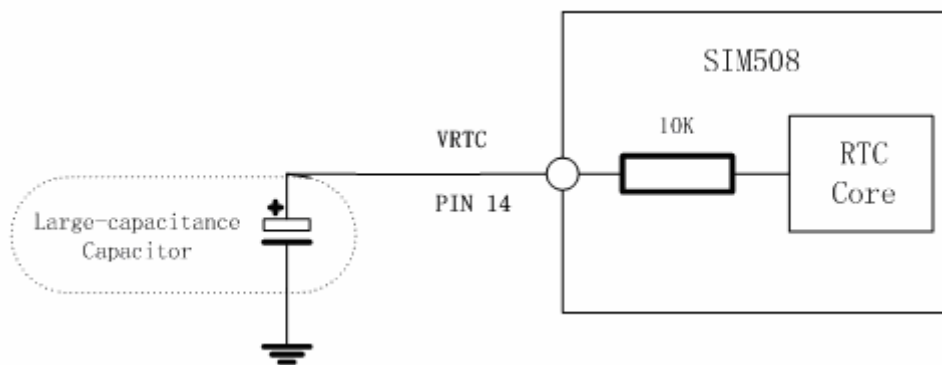

Figure 9: RTC supply from capacitor

- **Li-battery backup**

Rechargeable Lithium coin cells such as the TC614 from Maxell, or the TS621 from Seiko, are also small in size, but have higher capacity than the double layer capacitors resulting in longer backup times.

Typical charge curves for each cell type are shown in following figures. Note that the rechargeable Lithium type coin cells generally come pre-charged from the vendor.

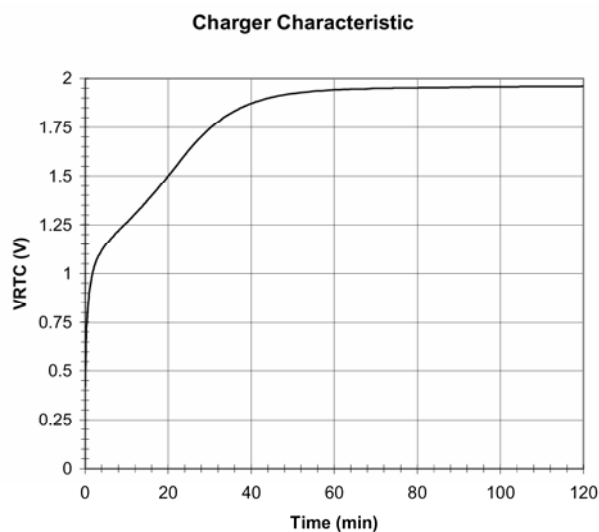

Figure 10: Panasonic EECEMOE204A Charge Characteristic

Charge characteristic

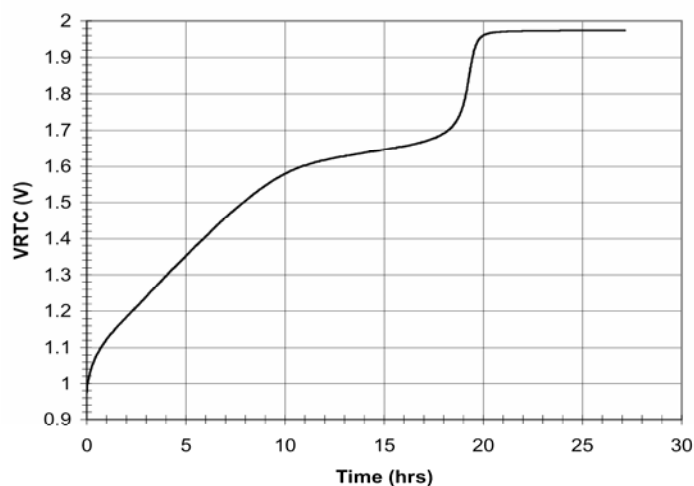

Figure 11: Maxell TC614 Charge Characteristic

Charger Characteristic

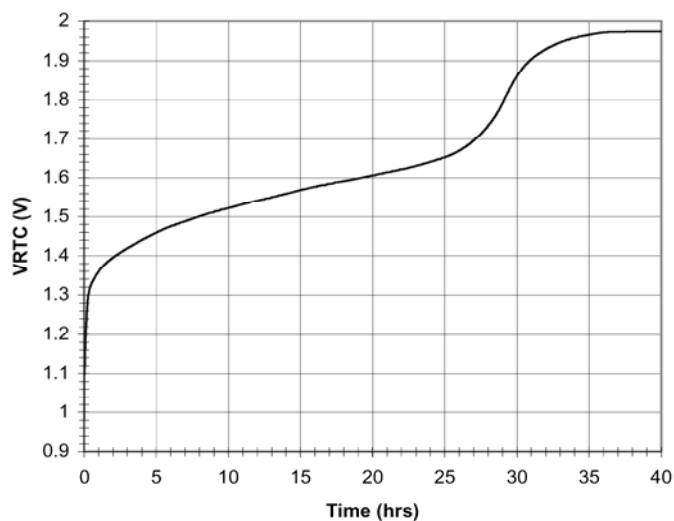

Figure 12: Seiko TS621 Charge Characteristic

Note:

Gold-capacitance backup

Some suitable coin cells are the electric double layer capacitors available from Seiko (XC621), or from Panasonic (EECEM0E204A). They have a small physical size (6.8 mm diameter) and a nominal capacity of 0.2 F to 0.3 F, giving hours of backup time.

3.9 GSM Serial interface

The GSM part of SIM508 provides two unbalanced asynchronous serial ports. One is the serial port and another is the debug port. The GSM part is designed as a DCE (Data Communication Equipment), following the traditional DCE-DTE (Data Terminal Equipment) connection, the module and the client (DTE) are connected through the following signal (as figure 13 shows).

Serial port

- Port/TXD @ Client sends data to the RXD signal line of module
- Port/RXD @ Client receives data from the TXD signal line of module

www.DataSheet4U.com

Debug port

- Port/TXD @ Client sends data to the DBG_RXD signal line of module
- Port/RXD @ Client receives data from the DBG_TXD signal line of module

All pins of all serial ports have 8mA driver, the logic levels are described in following table

Table 12: Logic levels of serial ports pins

Parameter	Min	Max	Unit
Logic low input	0	0.9	V
Logic high input	0.9	3.3	V
Logic low output	GND	0.2	V
Logic high output	2.8	3	V

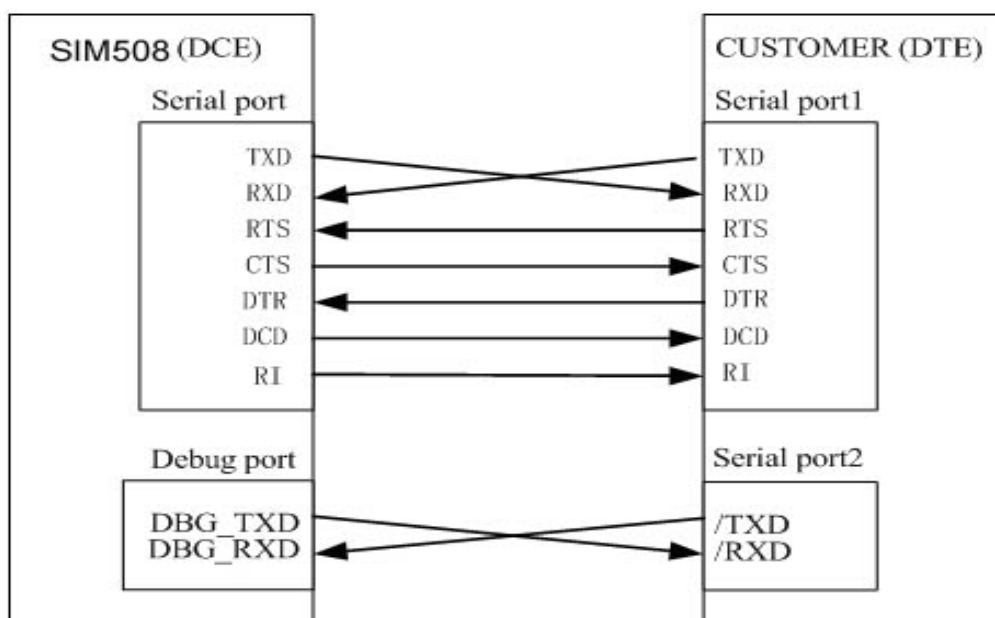

Figure 13: Interface of serial ports

3.9.1 Function of serial port & debug port supporting

Serial port

- Seven lines on Serial Port Interface
- Contains Data lines TXD and RXD, State lines RTS and CTS, Control lines DTR, DCD and RI;
- Serial Port can be used for CSD FAX, GPRS service and send AT command of controlling module. Serial Port can use multiplexing function;
- Serial Port supports the communication rate as following:
300,1200, 2400, 4800, 9600, 19200, 38400, 57600, 115200 Default as 115200bps.
- Auto-bauding supports the communication rate as following:
1200, 2400, 4800, 9600, 19200, 38400, 57600, and 115200bps.

www.DataSheet4U.com

Autobauding allows the GSM engine to automatically detect the bitrate configured in the host application. The serial interface of the GSM engine supports autobauding for the following bitrates: 1200, 2400, 4800, 9600, 19200, 38400, 57600, 115200. Factory setting is autobauding enabled. This gives you the flexibility to put the GSM engine into operation no matter what bitrate your host application is configured to. To take advantage of autobaud mode specific attention must be paid to the following requirements:

Synchronization between DTE and DCE.

Ensure that DTE and DCE are correctly synchronized and the baud rate used by the DTE is detected by the DCE (= ME). To allow the baud rate to be synchronized simply issue an "AT" or "at" string. This is necessary

- after you have activated autobauding
- when you start up the GSM engine while autobauding is enabled. It is recommended to wait 3 to 5 seconds before sending the first AT character. Otherwise undefined characters might be returned.

Restrictions on autobauding operation

- The serial interface has to be operated at 8 data bits, no parity and 1 stop bit (factory setting).
- The Unsolicited Result Codes like "RDY", "+CFUN: 1" and "+CPIN: READY" are not indicated when you start up the ME while autobauding is enabled. This is due to the fact that the new baud rate is not detected unless DTE and DCE are correctly synchronized as described above.

Note: You can use AT+IPR=x;&W to set a fixed baud rate and save the configuration to non-volatile flash memory. After the configuration was saved as fix baud rate, the Unsolicited Result Codes like "RDY" should be received from the serial port all the time when the SIM508 was power on.

Debug port

- Two lines on Serial Port Interface
- Only contains Data lines /TXD and /RXD
- Debug Port only used for debugging. It cannot be used for CSD call, FAX call. And the Debug port can not use multiplexing function;
- Debug port supports the communication rate as following:
9600, 19200, 38400, 57600, 115200

3.9.2 Software upgrade and Software debug

The TXD, RXD, DBG_TXD, DBG_RXD, GND must be connected to the IO connector when user need to upgrade software and debug software, the TXD, RXD should be used for software upgrade and the DBG_TXD, DBG_RXD for software debug. The PWRKEY pin is recommended to connect to the IO connector. The user also can add a switch between the PWRKEY and the GND. The PWRKEY should be connected to the GND when SIM508 is upgrading software. Please refer to the following figures.

www.DataSheet4U.com

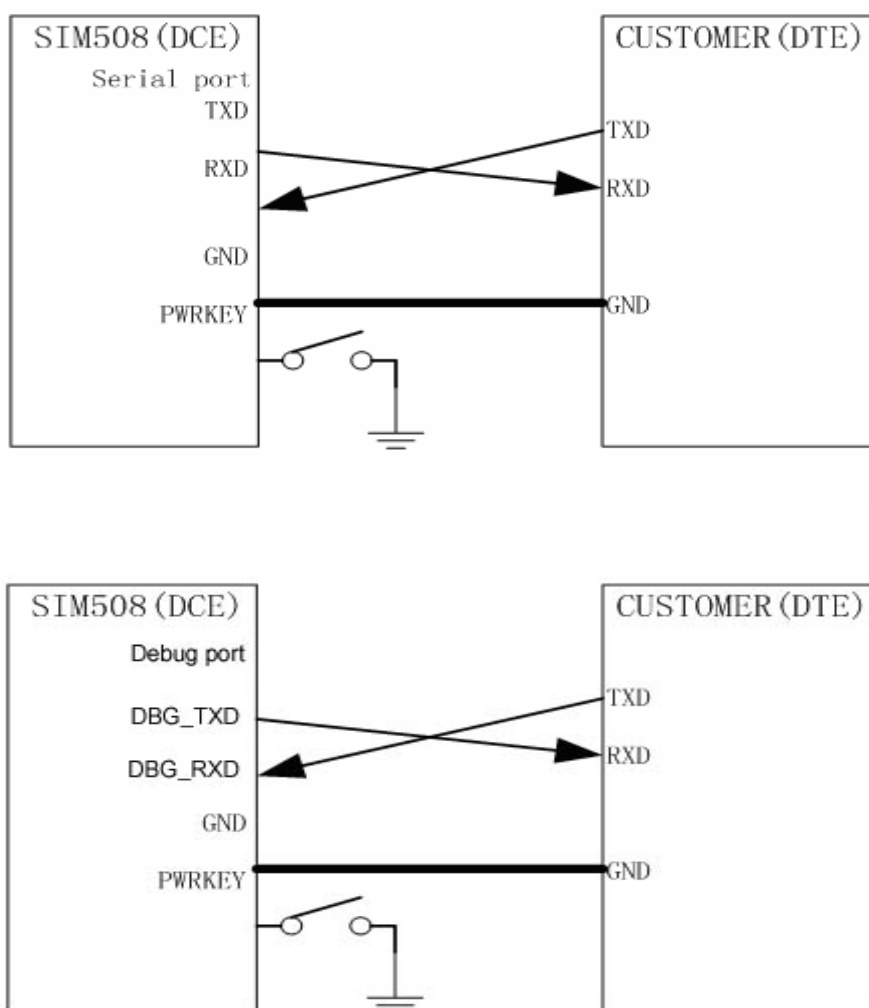

Figure 14: Interface of software upgrade&Debug

Note: The serial port doesn't support the RS_232, it only supports the TTL level. You should add the level converter IC between the DCE and DTE, if you connect it to the PC.

3.10 Audio interfaces

Table 13: Audio interface signal

	Name	Pin	Function
(AIN1/AOUT1)	MIC1P	54	Microphone1 input +
	MIC1N	56	Microphone1 input -
	SPK1P	53	Audio1 output+
	SPK1N	55	Audio1 output-
(AIN2/AOUT2)	MIC2P	58	Microphone2 input +
	MIC2N	60	Microphone2 input -
	SPK2P	57	Audio2 output+
	SPK2N	59	Audio2 output-

The module provides two analogy input channels, AIN1 and AIN2, which may be used for both microphone and line inputs. The AIN1 and AIN2 channels are identical. One of the two channels is typically used with a microphone built into a handset. The other channel is typically used with an external microphone or external line input. The module analogy input configuration is determined by control register settings and established using analogy multiplexers.

For each channels, you can use AT+CMIC to set the input gain level of microphone, use AT+ECHO to set the parameters for echo cancellation. Also, you can use AT+SIDET to set the side-tone level. For detail, please refer to *document [1]*..

It is suggested that you adopt the one of following two matching circuits in order to reject common mode noise and audio noise. The difference audio signals have to be layout according to difference signal layout rules.

Note:

As show in Figure 15、 Figure 16 、 Figure 17、 Figure18 (Note : all components package are 0603) . BEAD must have low impedance and can be removed according to their environment such as the ground plane, shielding, power lost. The best way is to plan all the components shown in the follow figure. If you want to adopt a amplifier circuit for audio, we commend National company's LM4890. But you can select it according to your needs.

3.10.1 Speaker interface configuration

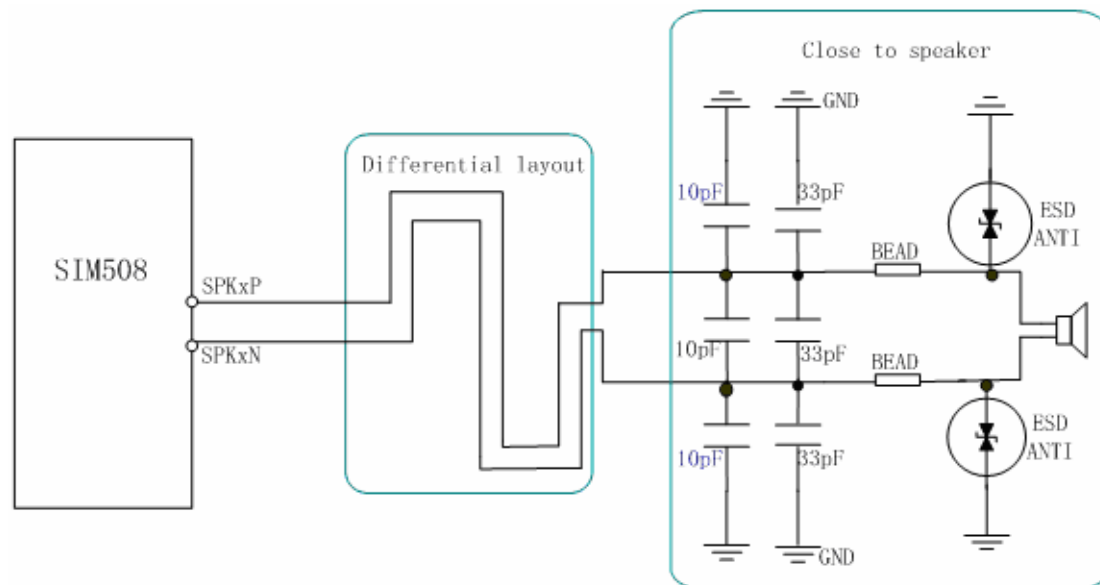

Figure 15: Speaker interface configuration

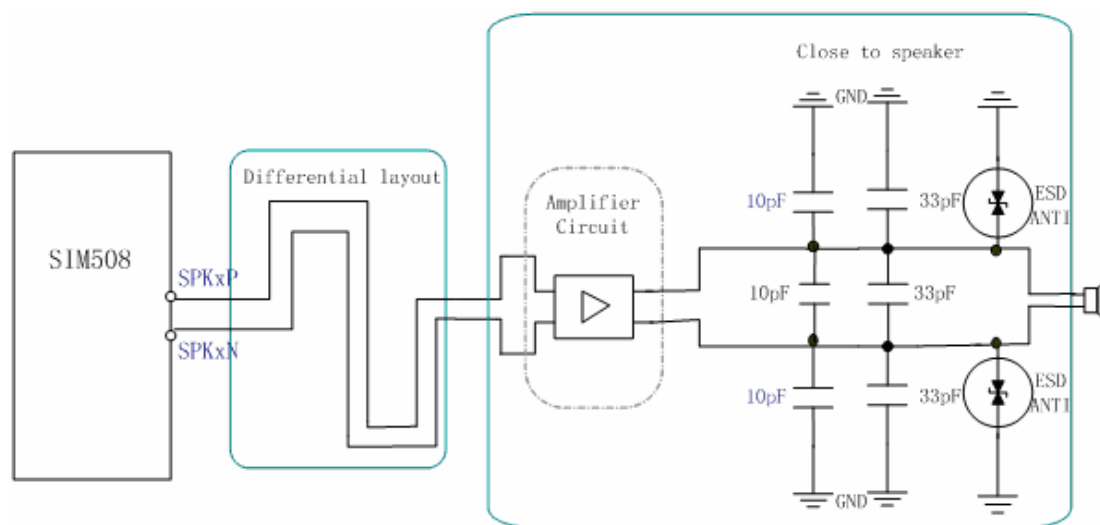

Figure 16: Speaker interface with amplifier configuration

3.10.2 Microphone interfaces configuration

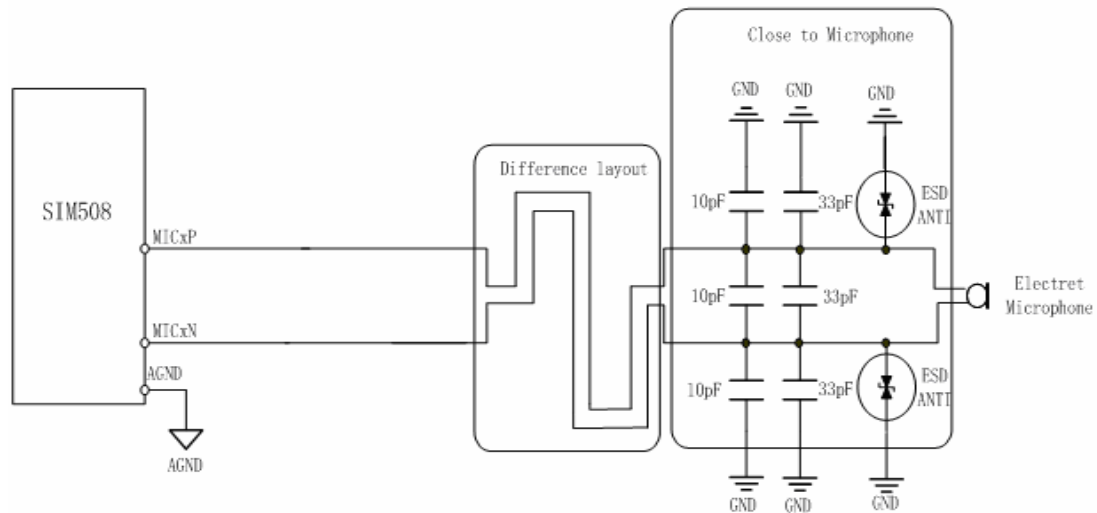

Figure 17: Microphone interface configuration

3.10.3 Earphone interface configuration

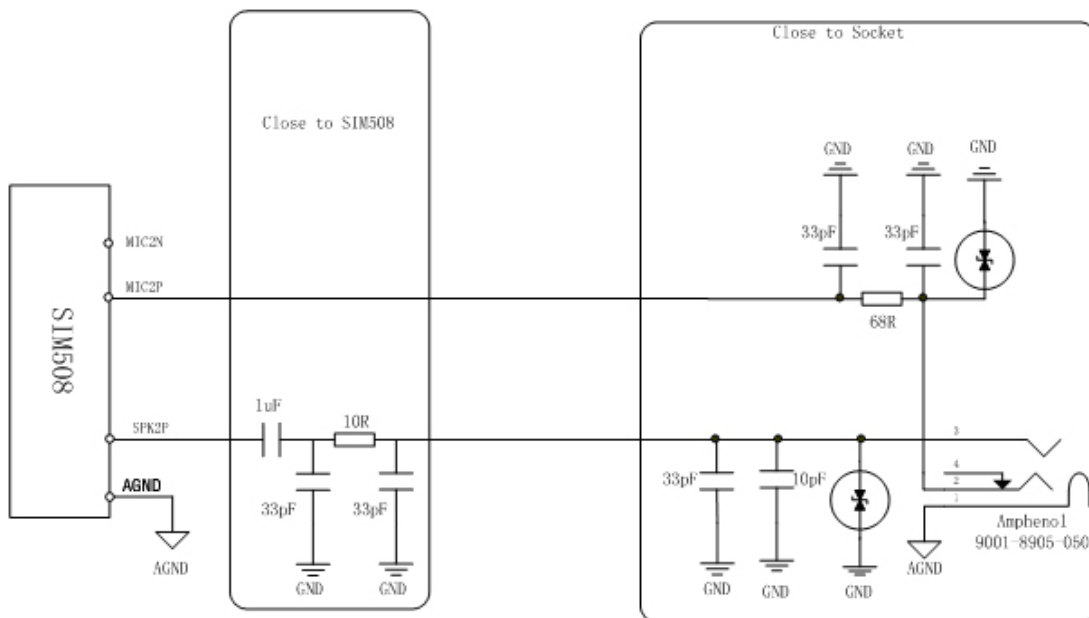

Figure 18: Earphone interface configuration

3.10.4 Referenced electronic characteristic

Table 14: MIC Input Characteristics

Parameter	Min	Typ	Max	Unit
Working Voltage		1.25	2.5	V
Working Current	5		300	uA
External Microphone Load Resistance	1.2	2.2		k Ohms

www.DataSheet4U.com

Table 15: SPK Output Characteristics

Parameter		Min	Typ	Max	Unit
Normal Output(SPK1)	Single Ended	load Resistance	27	32	Ohm
		Ref level		0.5477 -12.04	Vpp dBm
	Differential	load Resistance	27	32	Ohm
		Ref level		1.0954 -6.02	Vpp dBm
Auxiliary Output(SPK2)	Single Ended	load Resistance	27	32	Ohm
		Ref level		0.5477 -12.04	Vpp dBm
	Differential	load Resistance	27	32	Ohm
		Ref level		1.0954 -6.02	Vpp dBm

Table 16: Buzzer Output Characteristics

Parameter	Min	Typ	Max	Unit
Working Voltage	2.4	2.8	3.3	V
Working Current		8		mA
Load Resistance	1			k Ohms

3.11 SIM interface

3.11.1 SIM card application

You can use AT Command to get information in SIM card. For more information, please refer to *document [1]*.

The SIM interface supports the functionality of the GSM Phase 1 specification and also supports the functionality of the new GSM Phase 2+ specification for FAST 64 kbps SIM (intended for use with a SIM application Tool-kit).

Both 1.8V and 3.0V SIM Cards are supported.

The SIM interface is powered from an internal regulator in the module having nominal voltage 2.8V. All pins reset as outputs driving low. Logic levels are as described in table17

Table 17: Signal of SIM interface (board-to-board connector)

Pin	Signal	Description
25	SIM_VDD	SIM Card Power supply, it can identify automatically the SIM Card power mode, one is $2.85V \pm 0.1V$, another is $1.8V \pm 0.1V$. Current is about 10mA.
27	SIM_RST	SIM Card Reset
29	SIM_DATA	SIM Card data I/O
31	SIM_CLK	SIM Card Clock
33	SIM_PRESENCE	SIM Card Detection

Following is the reference circuit about SIM interface. We recommend an Electro-Static discharge device ST (www.st.com) ESDA6V1W5 or ON SEMI (www.onsemi.com) SMF05C for “ESD ANTI”.

The SIM_PRESENCE pin is used for detecting the SIM card removal. You can use the AT command “AT+CSDT” to set the SIMCARD configure. For detail of this AT command, please refer to *document [1]*:

You can select the 8 pins SIM card. The reference circuit about 8 pins SIM card illustrates as following figure.

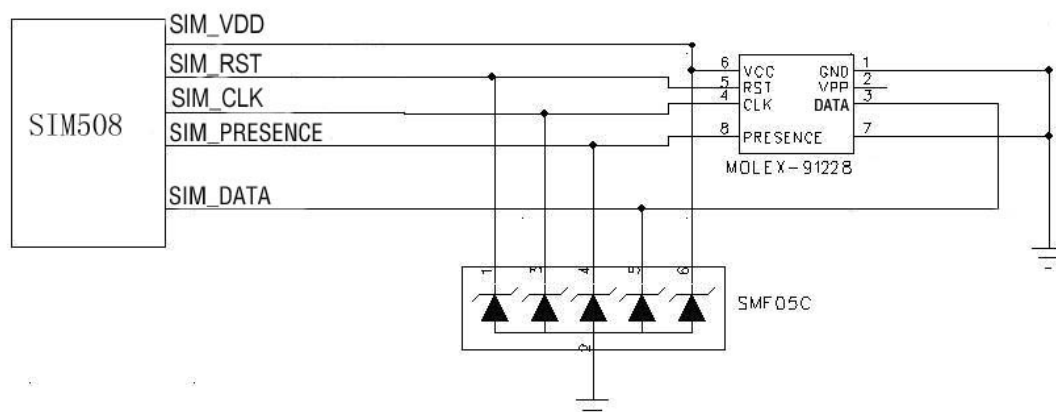

Figure 19: SIM interface reference circuit with 8pin SIM card

If you don't use the SIM card detection function, you can let the SIM_PRESENCE pin NC or connect to the GND. The reference circuit about 6 pins SIM card illustrate as following figure.

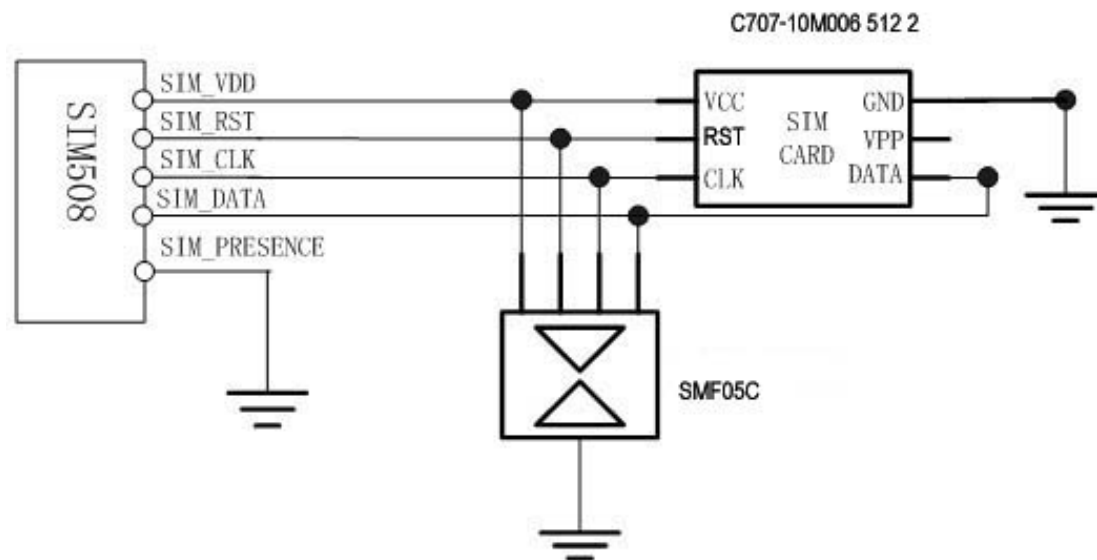

Figure 20: SIM interface reference circuit with 6pin SIM card

3.11.2 Design considerations for SIM card holder

For 6 pin SIM card, we recommend to use Amphenol C707-10M006 512 2 .You can visit <http://www.amphenol.com> for more information about the holder.

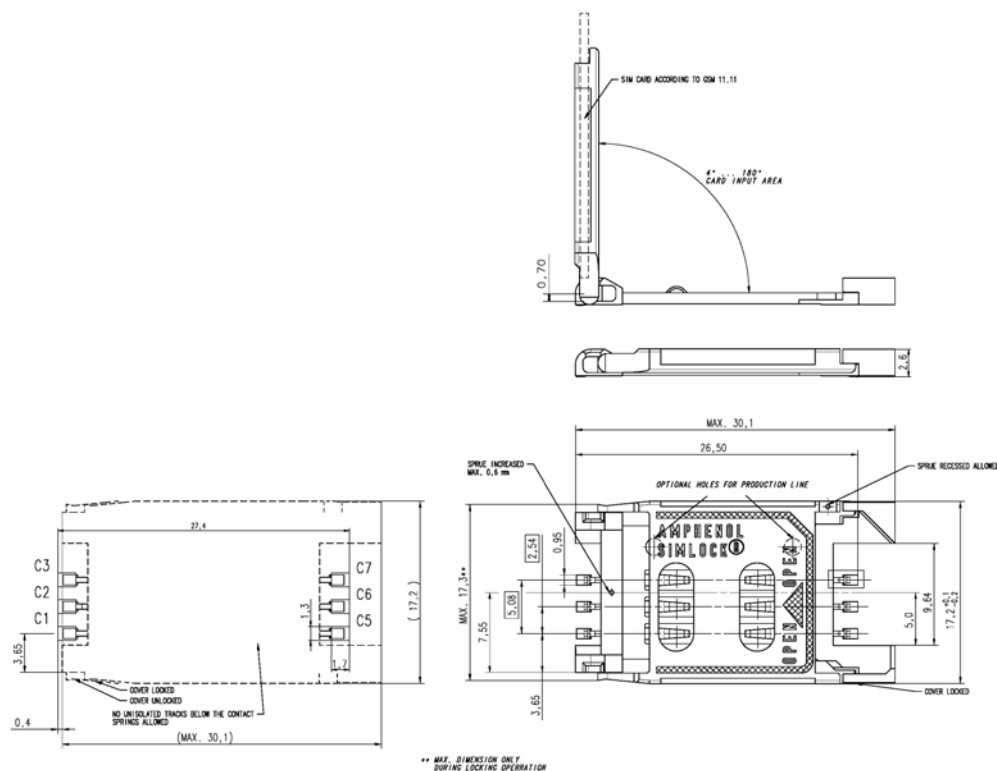

Figure 21: Amphenol C707-10M006 512 2 SIM card holder

Table 18: Pin description (Amphenol SIM card holder)

Pin	Signal	Description
C1	SIM_VDD	SIM Card Power supply, it can identify automatically the SIM Card power mode, one is 3.0V±10%, another is 1.8V±10%. Current is about 10mA.
C2	SIM_RST	SIM Card Reset.
C3	SIM_CLK	SIM Card Clock.
C5	GND	Connect to GND.
C6	VPP	Not connect.
C7	SIM_DATA	SIM Card data I/O.

For 8 pin SIM card, we recommend to use Molex 91228. You can visit <http://www.molex.com> for more information about the holder.

LCD display interface according to your application. When use as LCD interface, the following table is the pin define. LCD interface timing should be united with the LCD device.

Table 20: PIN define of LCD interface

Pin (On board-to-board connector)	Name	Function
38	DISP_CS	Display enable
40	DISP_CLK	Display clock for LCD
42	DISP_DATA	Display data output
44	DISP_D/C	Display data or command select
46	DISP_RST	LCD reset

3.13 General purpose input & output(GPIO)

Table 21: GPIO of the GSM part of SIM508

Pin	Name	Function
19	STATUS	The Status indication of the module, General Purpose Output Port
21	GPIO0	General Purpose Input/Output Port
35	GPIO1	General Purpose Input/Output Port

The GSM part of SIM508 supports 2 general purpose input/output signal pins and output signal pins. Both pins can be configured through AT command “AT+CGPIO” in users’ application to high voltage level or low voltage level. For detail of this AT command, please refer to *document [1]*.

3.14 ADC

The GSM part of SIM508 provide two auxiliary ADC (General purpose analog to digital converter.) as voltage input pin, which can be used to detect the values of some external items such as voltage、temperature etc. User can use AT command “AT+RADC” to read the voltage value added on ADC pin. For detail of this AT command, please refer to *document [1]*.

Table 22: ADC pin of the GSM part of SIM508

Name	Pin (On board-to-board connector)	Input voltage scope(V)
AUXADC1	12	0 – 2.4

3.15 Behaviors of the RI line (serial port1 interface only)

Table 23: Behaviours of the RI line

State	RI respond
-------	------------

Standby	HIGH
Voice calling	Change LOW, then: (1) Change to HIGH when establish calling. (2) Use AT command ATH the RI pin changes to HIGH.. (3) Sender hang up, change to HIGH
Data calling	Change LOW, then: (1) Change to HIGH when establish calling. (2) Use AT command ATH the RI changes to HIGH.
SMS	When receive SMS, The RI will change to LOW and hold low level about 120ms, then change to HIGH.

If the module is used as caller, signal RI will maintain high. But when it is used as receiver, following is timing of RI.

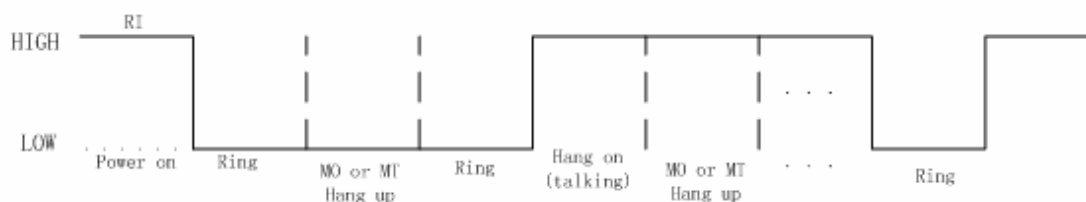

Figure 23: The GSM part of SIM508 Services as Receiver

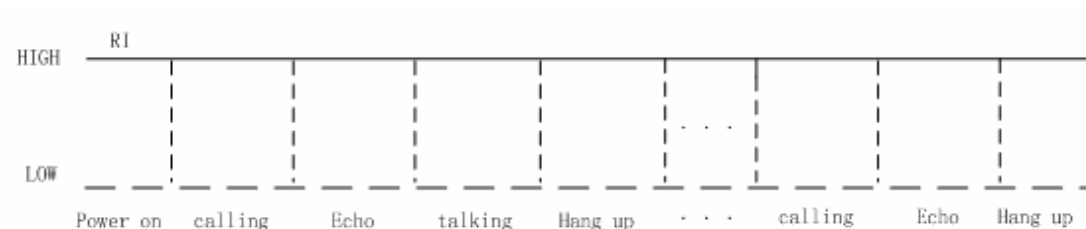

Figure 24: The GSM part of SIM508 Services as caller

3.16 Network status indication LED lamp

The PIN16 on the board-to-board connector can be used to drive a network status indication LED lamp. The working state of this pin is listed in table;

Table 24: Working state of network status indication LED pin

State	The GSM part of SIM508 function
Off	The GSM part of SIM508 is not running
64ms On/ 800ms Off	The GSM part of SIM508 does not find the network
64ms On/ 3000ms Off	The GSM part of SIM508 find the network
64ms On/ 300ms Off	GPRS communication

We provide a reference circuitry for you, shown as the following figure:

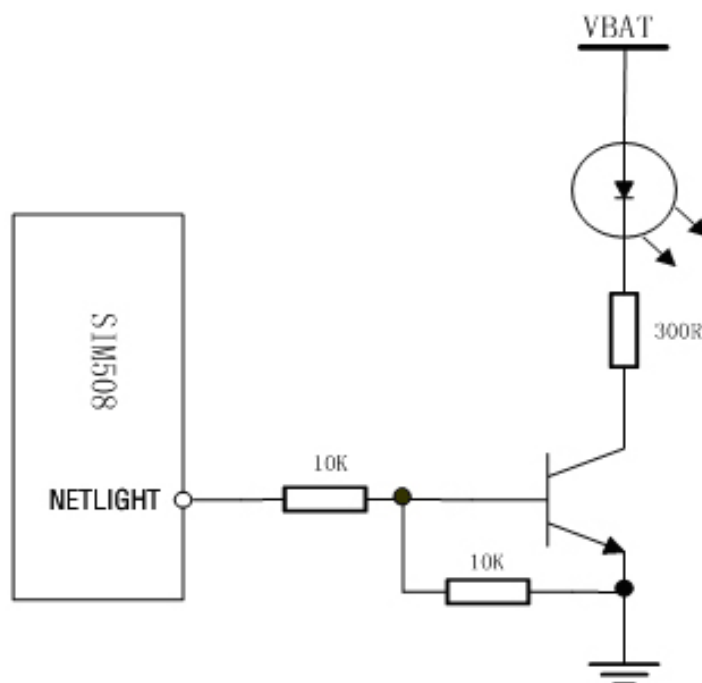

Figure 25: Reference circuit for Network status LED

3.17 Buzzer

The PIN 23 on the board-to-board connector can be used to drive a buzzer to indicate incoming call. The output volume of buzzer can be set by “AT+CRSL”. The reference circuit for buzzer as shown as the following figure:

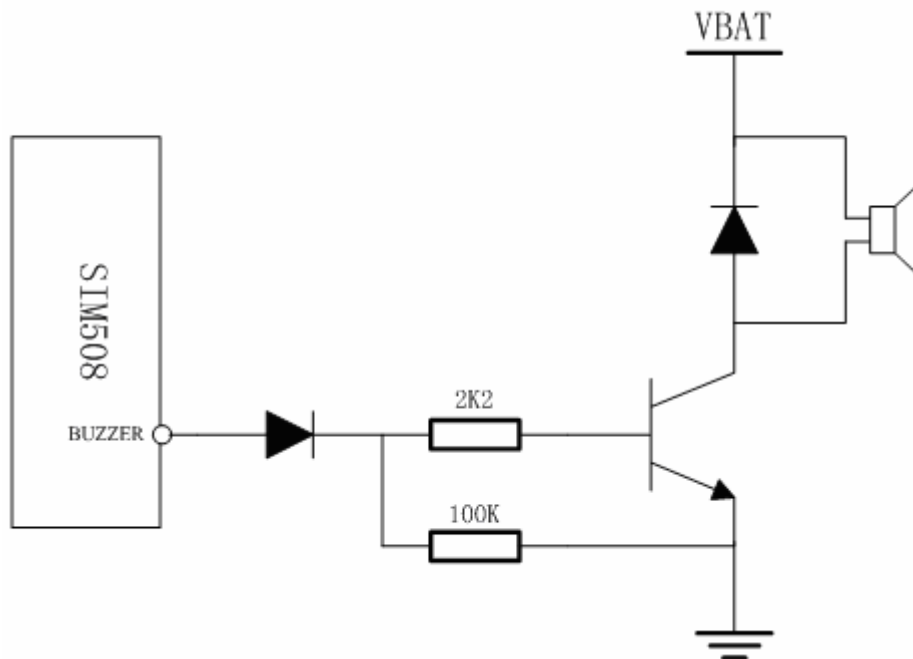

Figure 26: Reference circuit for Buzzer

4 GPS Application Interface

A GPS receiver with high performance has been integrated to offer GPS full function, it continuously tracks all satellites in view and provides accurate satellite position data. Otherwise, the GPS part can run separately even while the GSM part of SIM508 has been deregistered from the GSM network.

4.1 Theory of operation

The theory of operation is shown in the following figure:

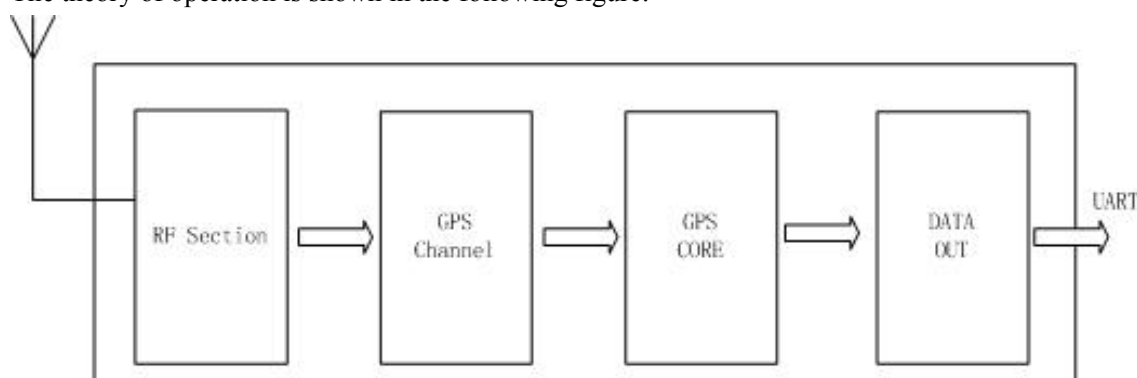

Figure 27: Theory of operation

The SIM508 GPS part is designed to use L1 Frequency (C/A Code) GPS receiver and performs the entire GPS signal processing, from antenna input to serial position data output.

The processing steps involved are:

RF section

In the RF section the GPS signal detected by the antenna is amplified, filtered and converted to an intermediate frequency (IF). An A/D converter converts the analogue intermediate frequency into a digital IF signal.

GPS channels

The received digital IF signal bit stream is passed to the baseband section, where it is fed into the correlators. The function of the correlators is to acquire and track the satellite signals. There are 12 channels used in parallel, with each correlator looking for a characteristic PRN code sequence in the bit stream. Once the correlator has found a valid signal, pseudo range, carrier phase and orbit information can be extracted from the GPS signal.

GPS CORE

The on-board processor is running an algorithm that calculates the position, velocity and time. This calculation is called navigation solution. Once the navigation solution is calculated, it can be transformed into the desired coordinate system, e.g. Latitude/Altitude.

DATA OUT

The data of the navigation solution are available at the serial RS-232 interface.

4.2 Technical data

Power consumption

210 mW with active antenna (continuous mode),

180mw with Passive antenna (continuous mode)

Push-to-Fix reduces power by as much as 98%

Note: This function need more software supporting form SIMCOM Ltd, please contact us for more detail.

www.DataSheet4U.com

Protocols

SiRF binary/NMEA-0183

AI3/F (SiRF Interface) for A-GPS

RTCM (for DGPS)

Position accuracy

Autonomous: < 10m

SBAS (WASS, EGNOS: < 5m)

Beacon DGPS: < 3m

Receiver

Tracking: L1, C/A code

Channels: 20

Update rate: Default 1 Hz

Tracking Sensitivity: -157 ± 2 dBm (see note)

Max. Altitude: <60.000 ft (18,000 m)

Max. velocity: <1.000 knots (515 m/s)

Protocol support: NMEA-0183, SiRF binary

Acquisition rate

Standalone

Hotstart: < 1 seconds, open sky

Warmstart: < 38 seconds, open sky

Coldstart: < 42 seconds, open sky

A-GPS

GSM or 3G: <1s, open sky

GSM or 3G: <24s, indoor

CDMA: <1s, open sky

CDMA: <18s, indoor

Note:

1) The receiver sensitivity above-mentioned is mostly related to antenna reference point, such as the antenna type, the antenna amplifier, the customer application or the placement and the applied reference setup and so on.

2) *A-GPS: This function needs more supporting form the mobile telecommunication network. A-GPS support, based on the A-GPS firmware. Now the standard version of the firmware in SIM508 does not support A-GPS.*

4.3 Pin description

Table 25: Pin description

Power Supply			
PIN NAME	I/O	DESCRIPTION	
GPS_VCC	I	Two GPS_VCC pins of the board-to-board connector are dedicated to connect the supply voltage. The power supply for GPS whole part has to be a single voltage source It must be able to provide sufficient current of >150mA in the procedure of tracking satellites	Vmax= 5.0V Vmin=3V Vnorm=3.3V
GPS_VRTC	I	Apply 3V dc for backup RTC & SRAM. If unused, leave it open.	Vmax= 3.3V Vmin=2.7V Vnorm=3.0V
GPS_VANT	I	The external DC power supply for an active GPS antenna. It's input voltage depends on the type of chosen active antenna, for the 5V type, it has to be connected to 5V external power supply; for the 3V type, it can be connected to the GPS_VCC_RF pin directly which provides 2.85V DC.	Imax=25mA Vmax=5V Vmin=2.85V
GPS_VCC_RF	O	The optional power supply for 3.0V type active antenna.	Vmax=2.9V Vmin=2.8V Vnorm=2.85V Imax=25mA
GND		Ground, shared with GSM part	
GPIO			
PIN NAME	I/O	DESCRIPTION	
GPS_GPIO13	I/O	Reserved.	It is reserved for customer specific applications. Leave it open.
GPS_GPIO14	I/O	Reserved.	It is reserved for customer specific applications. Leave it open.
Dual serial interface			
PIN NAME	I/O	DESCRIPTION	

GPS_TXA	O	Serial data output for port A	
GPS_RXA	I	Serial data input for port A	
GPS_TXB	O	Serial data output for port B	
GPS_RXB	I	Serial data input for port B	
Control signals			
PIN NAME	I/O	DESCRIPTION	
GPS_BOOTSEL	I	For re-programming the Flash, it must be set to High	
GPS_M-RST	I	Reset pin, active low. If used, it causes the module to reset; if not used, leave it open .	Note, if this pin is pulled down by a GPIO, then the GPIO must have the capability of inputting 1.5mA current.
GPS_Timersync	I	an auxiliary clock input that supports alternate oscillator calibration systems. Alternate functions are CS3 and GPIO 15.	Reserved for A-GPS. If not used, leave it open.
GPS_FREQ_XFER	I	Reserved	Leave it open.
GPS_TimeMark	O	1 PPS timemark output for synchronizing to within 1 microsecond of GPS time.	If not used, leave it open.
GPS_WAKEUP	I	It only be used to wakeup the system from PTF mode. If not used, the user must connect this pin to the ground through a 0R resistor.	
NC		All the pins named NC, Do not use, leave it open.	

Table 26: Consolidated PIN Characteristics

PIN	Default Direction	100K Ω PULL UP
GPS_TXA	O	
GPS_RXA	I	×
GPS_TXB	O	
GPS_RXB	I	×

4.4 Turn on the GPS part of SIM508

To turn on the GPS module, the GPS_VCC must be higher than 2.3V, and should be kept on for 220mS at least. The theory of turning on is shown in the following figure:

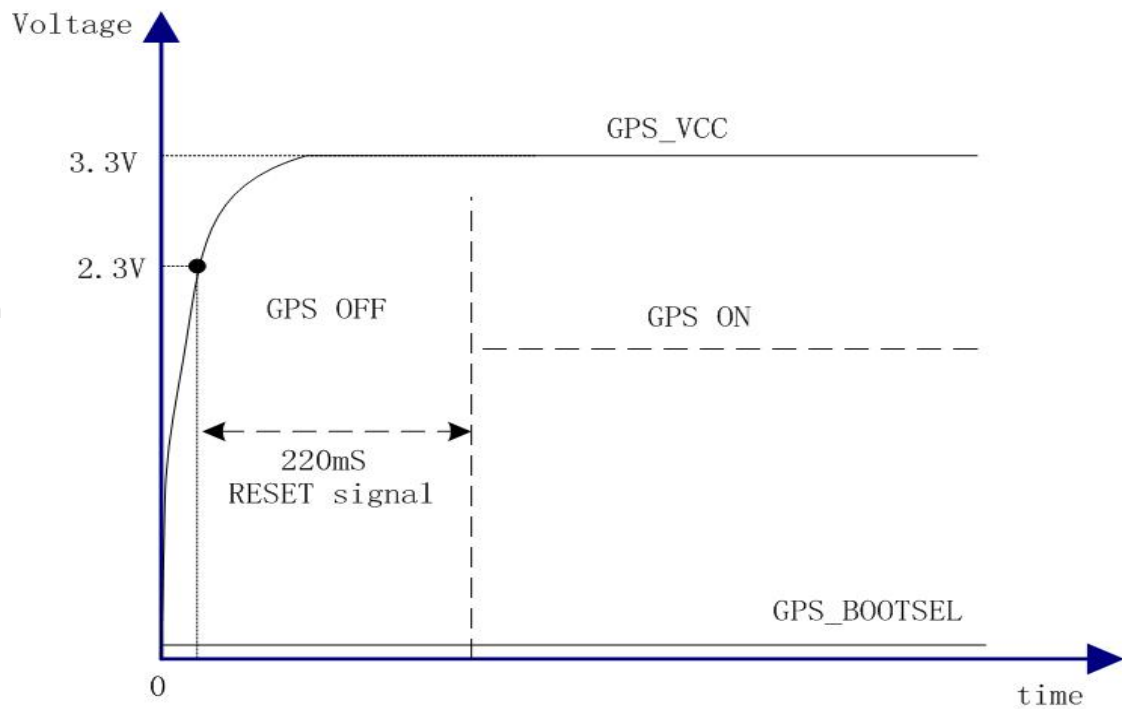

Figure 28: Turn on the GPS module

4.5 The theory of the GPS RTC circuit

The RTC is very important for the GPS module, because the data kept in the SRAM is depended on the VRTC. Please keep the VRTC on if you want to use the function of hotstart, warmstart, or Push-To-Fix mode. There is a RTC LDO in our SIM508 module, it can provide 1.5V voltage to the SRAM. The theory of RTC circuit is shown in the following figure:

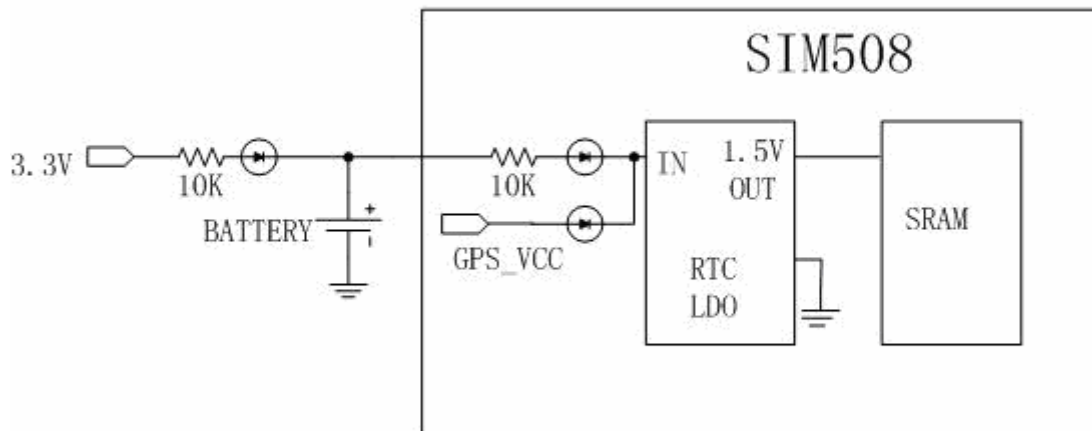

Figure 29: Theory of the GPS RTC circuit

4.6 The theory of the RESET Circuit

There is a RESET IC in the SIM508 module. If the input of the reset IC is lower than 2.3V, the “reset” pin will keep low; then the input voltage is higher than 2.3V, the RESET IC will output a low level voltage for about 220mS as a reset signal. After that the reset output pin will be kept high. So, if the user wants to reset SIM508 GPS part, the GPS_M-RST should be pulled down longer than 10mS and then pull it up. The theory of the RESET Circuit is shown in the figure:

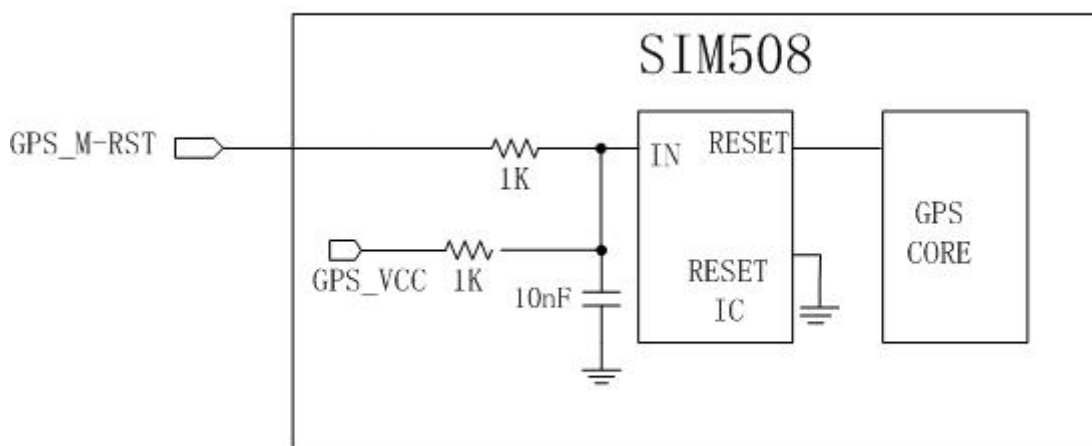

Figure 30: Theory of the RESET circuit

4.7 GPS operation modes

Table 27: GPS operation modes

Mode	Function
Normal operation	The receiver is continuously running in Normal mode, as long as the operating voltage Vcc is supplied. Position fixes are generated at the maximum update rate. This enables the receiver a warm- and hotstart. However, the cold- and warmstart times of receiver do not differ significantly under good visibility conditions.
Power Down mode	In this mode the user can cut off the GPS_VCC to save more power consumption. But the VRTC must always be on. When the user resumes the GPS_VCC, the receiver wakes up, a valid position can be computed in the normal hot-start time.
Push-to-Fix mode (See Note)	In this mode the receiver will turn on every a given minutes (this period can be set form 10 minutes to 2 hours by software) to perform a system update consisting of position, time, ephemeris data refreshing and RTC calibration. When the PTF mode is enabled, upon power on or a new PTF cycle, the receiver will stay on full power until the good navigation solution is computed. The stand-by state will follow for the remainder of the period. For example, if it took 36 seconds to fix position and refresh ephemeris on the default period of 30 minutes, the receiver will sleep for the 29 minutes and 24 seconds. When the application needs a position report, it can toggle the GPS_M-RST pin to wake up the receiver. When the receiver wakes up, a valid position can be computed in the normal hot-start time.

4.8 Serial interface of the SIM508 GPS part

The GPS part of the SIM508 module offers two serial interfaces, Allows for different protocols to operate on each port.

For example:

Serial port A

- 2-wire serial interface
- Includes the GPS_RXA(receive) and GPS_TXA (transmit) lines
- Supported baud rate: 1200—115200 bps
- Protocol: Default SiRF binary ,57600bps

Serial port B

- 2-wire serial interface
- Includes the GPS_RXB (receive) and TXB (transmit) lines
- Supported baud rate: 1200 -115200bps, but 4800 - 38400bps is a common rate range
- Protocol: Default NMEA ,4800bps
- Default output message: GGA,GSA, GSV,RMC,VTG
- Update rate: Default 1Hz
- Datum WGS84 default (User configurable)

- Notes: 1.Both interfaces are configured as 8 data bits, no parity and 1 stop bit..*
- 2. The serial ports also can be configured to adapt to customer specific applications, such as for DGPS, and so on. More detail please contact with Simcom ltd.*
- 3 .We can also help the user to change the protocol and baud rate of the two serial ports by different firmware. For more detail please contact SIMCOM Ltd.*

4.9 Start-up procedure

The start-up strategy of the SIM508 GPS part depends on the last position, current time and ephemeris data, that the receiver has stored the external SRAM memory. There are three different start-up procedures:

4.9.1 Coldstart

The coldstart takes place when the receiver has no knowledge of its last position or time. In this case the GPS RTC has not been running and no valid ephemeris data or almanac data is available (The receiver has never been navigating or no battery backup memory available).

4.9.2 Warmstart

This start-up procedure is performed whenever the receiver is able to use the valid almanac data, and has not in an important manner moved since the last valid position calculation. This procedure starts if the receiver has been shut off for more than 2 hours, but the last position, time and almanac are still acknowledged. This procedure is able to announce the current visible satellites in advance. However, since ephemeris data are not available or cannot longer be used, the receiver has to wait for the ephemeris broadcast to complete.

4.9.3 Hotstart

Hotstart is performed whenever the receiver still has access to valid ephemeris data and exact time. This procedure starts if the receiver has been shut off for less than 2 hours and the GPS RTC has been running during that time. Furthermore, during the previous session, the receiver must have been navigating (to allow it to decode and store ephemeris data). In Hotstart, the receiver can announce in advance the currently visible satellites, and is therefore able to quickly obtain and track the signal. Due to the fact that ephemeris is already known, there is no need to wait for the ephemeris broadcast to complete.

5 Antenna interface

5.1 GSM Antenna

The RF interface has an impedance of 50Ω. To suit the physical design of individual applications SIM508 offers two alternatives:

- Recommended approach: antenna connector on the component side of the PCB
- Antenna pad and grounding plane placed on the bottom side.

www.DataSheet4U.com

To minimize the loss on the RF cable, it need be very careful to choose RF cable. We recommend the insertion loss should be meet following requirement:

- GSM900<1dB
- DCS1800/PCS1900<1.5dB

5.1.1 Antenna connector

SIM508 use MURATA's MM9329-2700 RF connector on the module side, we recommend user use MURATA's MXTK92XXXXX as matching connector on the application side. Please refer to appendix for detail info about MURATA's MXTK92XXXXX.

5.1.2 Antenna pad

The antenna can be soldered to the pad, or attached via contact springs. To help you to ground the antenna, SIM508 comes with a grounding plane located close to the antenna pad. The antenna pad of SIM508 is shown as the following figure:

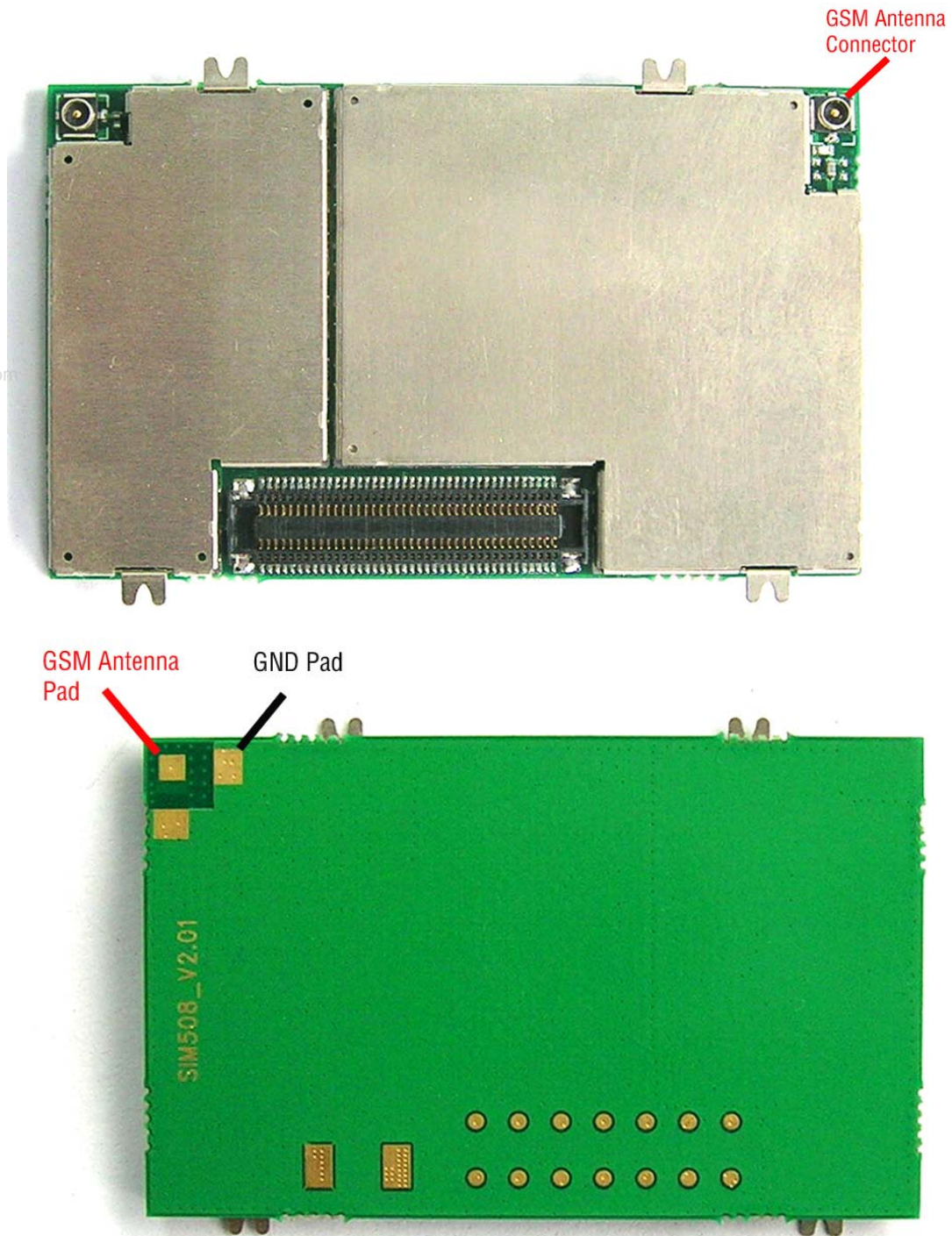

Figure 31: RF connector and RF pad

The GSM part of SIM508 material properties:
The GSM part of SIM508 PCB Material: FR4
Antenna pad: Gold plated pad

5.1.3 Module RF output power

Table 28: The GSM part of SIM508 conducted RF output power

Frequency	Max	Min
E-GSM900	33dBm ±2db	5dBm±5db
DCS1800	30dBm ±2db	0dBm±5db
PCS1900	30dBm ±2db	0dBm±5db

www.DataSheet4U.com **5.1.4 Module RF receive sensitivity**

Table 29: The GSM part of SIM508 conducted RF conducted receive sensitivity

Frequency	Receive sensitivity
E-GSM900	< -106dBm
DCS1800	< -106dBm
PCS1900	< -106dBm

5.1.5 Module operating frequencies

Table 30: The GSM part of SIM508 operating frequencies

Frequency	Receive	Transmit
E-GSM900	925 ~ 960MHz	880 ~ 915MHz
DCS1800	1805 ~ 1880MHz	1710 ~ 1785MHz
PCS1900	1930 ~ 1990MHz	1850 ~ 1910MHz

5.2 GPS Antenna

5.2.1 GPS Antenna Connection

SIM508 provide an Antenna Connector for customer to connect GPS antenna via a proper Microwave Coaxial Cable. About the connector's type and the matched Microwave Coaxial Cable, please refer to 5.1.1. The location of the GPS Antenna Connector can be found in the following figure.

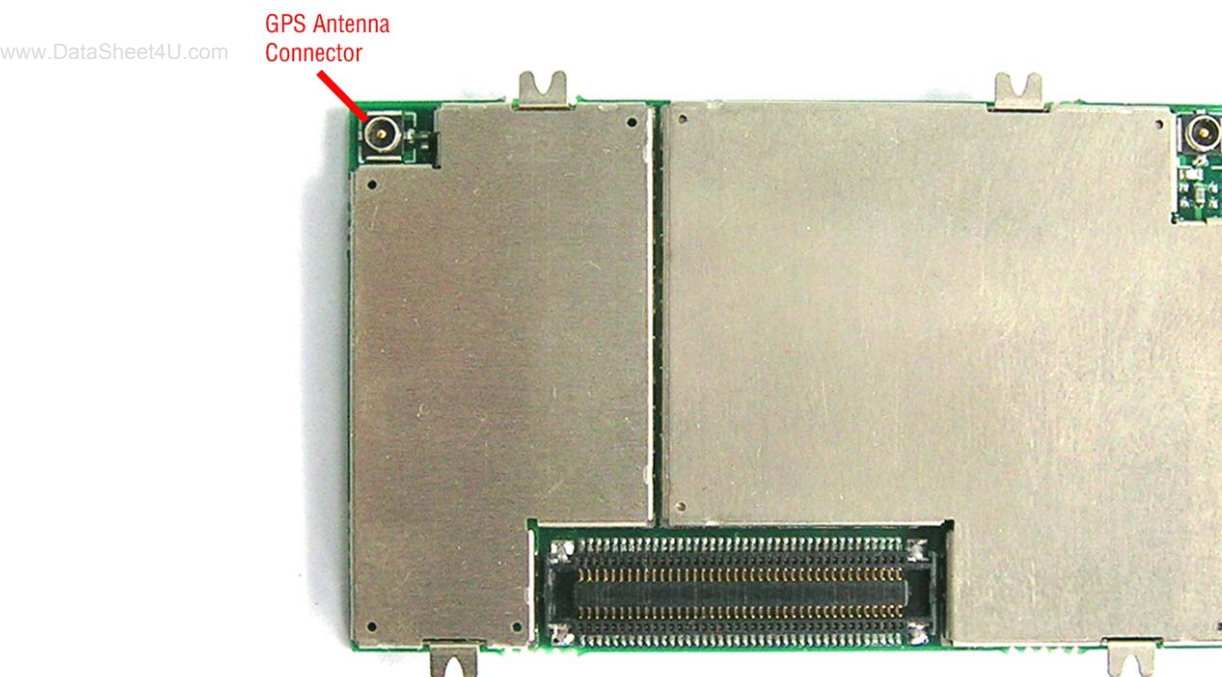

Figure 32: RF connector

5.2.2 GPS Antenna Choice Consideration

To obtain excellent GPS reception performance, A GOOD antenna will ALWAYS be required. The antenna is the most critical item for successful GPS reception in a weak signal environment. Proper choice and placement of the antenna will ensure that satellites at all elevations can be seen, and therefore, accurate fix measurements are obtained. Most customers contract with antenna design houses to properly measure the radiation pattern of the final mounted configuration in a plastic housing with associated components near the antenna. Linear antennas are becoming more popular, and the gain is reasonable, since a smaller ground plane can be used. Chose a linear antenna with a reasonably uniform hemispherical gain pattern of $>-4\text{dBi}$. Use of an antenna with lower gain than this will give less than desirable results. Please note that a RHCP antenna with a gain of -3dBic , equates to a linear polarized antenna of -0dBi . Proper ground plane sizing is a critical consideration for small GPS antennas. Proper placement of the GPS antenna should always be the FIRST consideration in integrating the SIM508 GPS Module.

If the customer's design will allow for a ceramic RHCP patch antenna with an appropriately sized ground plane, and the patch is normally oriented towards the sky, then that particular solution usually works the best. Please note that if the patch antenna ground plane is less than 60x60mm, then compromises to the beam width and gain pattern could result. Usually the gain becomes very directional, and loses several dB of performance. Since results can vary, measuring the antenna radiation pattern in the final housing in an appropriate anechoic chamber will be required.

Some customers do not have the size availability to implement a patch antenna approach. In that instance, use of a Linear Polarized (LP) antenna is the next best alternative. There are new ceramic LP antennas on the market that exhibit reasonable gain characteristics once properly mounted in the housing, and when mated to an appropriate sized ground. That is the key point to consider here. "When mated to an appropriate sized ground".

Usually, the ground plane requirements are smaller for a LP antenna when compared to a patch, but once again, proper testing in an anechoic chamber is a mandatory requirement. These ceramic elements will need to be located near the end of the ground plane, and will require several mm of clearance between the closest component.

It is important to note that use of a LP antenna will result in a minimum of 3dB of gain loss when compared to a RHCP antenna at a defined elevation. This is due to the right hand gain rule of antenna propagation.

Use of PIFA antenna is another LP possibility, but the PIFA usually exhibits a considerable amount of gain nulls, or "holes" in the radiation pattern. This will be undesirable for obtaining a low circular error probability (CEP), since the antenna may not allow the receiver to capture the desired satellite at the ideal orientation due to these noted gain nulls.

Once again, careful testing in an appropriate anechoic chamber is required.

If the customer's design is for automotive applications, then an active antenna can be used and located on top of the car in order to guarantee the best signal quality.

Here are two GPS antenna manufacturers recommended, you can visit their websites for details, <http://www.inpaq.com.tw> and <http://www.passivecomponent.com>. But the GPS antenna choice should be based on the designing product and other conditions.

For detailed Antenna designing consideration, please refer to related antenna vendor's design recommendation. The antenna vendor will offer further technical support and tune their antenna characteristic to achieve successful GPS reception performance depends on the customer's design.

6 Electrical, reliability and radio characteristics

6.1 Absolute maximum ratings

Absolute maximum rating for power supply and voltage on digital and analog pins of SIM508 are list in table31 and table 32.

Table 31: Absolute maximum ratings (GSM part)

Parameter	Min	Max	Unit
Peak current of power supply	0	4.0	A
RMS current of power supply (during one TDMA- frame)	0	0.7	A
Voltage at digital pins	-0.3	3.3	V
Voltage at analog pins	-0.3	3.0	V
Voltage at digit/analog pins in POWER DOWN mode	-0.25	0.25	V

Table 32: Absolute maximum ratings (GPS part)

Parameter	Min	Max	Unit
Voltage at GPS_VCC	-0.3	5	V
Current at GPS_VCC_RF		25	mA

6.2 Operating temperatures

The operating temperature is listed in table33:

Table 33: SIM508 operating temperature

Parameter	Min	Typ	Max	Unit
Ambient temperature	-20	25	55	°C
Restricted operation*	-30 to -20		55 to 80	°C
Storage temperature	-40		+85	°C

* SIM508 can work, but the deviation from the GSM specification may occur.

6.3 Power supply rating

Table 34: Power supply rating (GSM part)

Parameter	Description	Conditions	Min	Typ	Max	Unit
VBAT	Supply voltage	Voltage must stay within the min/max values, including voltage drop, ripple, and spikes.	3.4	4.0	4.5	V
	Voltage drop during transmit burst	Normal condition, power control level for Pout max			400	mV
	Voltage ripple	Normal condition, power control level for Pout max @ f<200kHz @ f>200kHz			50 2	mV
IVBAT	Average supply current)	POWER DOWN mode		35		uA
		SLEEP mode (BS-PA-MFRMS=5)		2.5		mA
		IDLE mode (Not connect console) EGSM 900 DCS 1800/ PCS 1900		23 23		mA
		IDLE mode (connect console) EGSM 900 DCS 1800/ PCS 1900		33 33		mA
		TALK mode EGSM 900 DCS 1800/ PCS 1900		260 200		mA
		DATA mode, GPRS(3 Rx,2Tx) EGSM 900 DCS 1800/ PCS 1900		470 340		mA
		DATA mode, GPRS(4 Rx,1Tx) EGSM 900 DCS 1800/ PCS 1900		275 220		mA
		Peak supply current (during transmission slot every 4.6ms)	Power control level		2	3.1

Table 35: Power supply rating (GPS part)

Parameter	Description	Conditions	Min	Typ	Max	Unit
GPS_VCC	Supply voltage		3.0	3.3	5	V
IGPS_VCC	Average supply current	Continuous mode (with antenna feeding on GPS_VCC_RF)		65	110	mA

Note: Basing on current standard GSW3 soft version, the power saving mode of GPS part is not available, that results 65 mA IGPS_VCC remained while the GPS receiver is running in normal mode.

www.DataSheet4U.com

6.4 Current consumption

6.4.1 The current consumption of the SIM508 GSM part.

Table 36: Current consumption (GSM part)

Voice Call	
GSM 900	@power level #5 <350mA, Typical 260mA @power level #10, Typical 130mA @power level #19, Typical 86mA
DCS 1800/ PCS 1900	@power level #0 <300mA, Typical 200mA @power level #10, Typical 87mA @power level #15, Typical 80mA
GPRS Data	
DATA mode, GPRS (1 Rx,1 Tx)CLASS 8	
GSM 900	@power level #5 <350mA, Typical 260mA @power level #10, Typical 125mA @power level #19, Typical 84mA
DCS 1800/ PCS 1900	@power level #0 <300mA, Typical 200mA @power level #10, Typical 83mA @power level #15, Typical 76mA
DATA mode, GPRS (3 Rx, 2 Tx)CLASS 10	
GSM 900	@power level #5 <550mA, Typical 470mA @power level #10, Typical 225mA @power level #19, Typical 142mA
DCS 1800/ PCS 1900	@power level #0 <450mA, Typical 340mA @power level #10, Typical 140mA @power level #15, Typical 127mA
DATA mode, GPRS (4 Rx,1 Tx)CLASS 8	
GSM 900	@power level #5 <350mA, Typical 270mA @power level #10, Typical 160mA @power level #19, Typical 120mA
DCS 1800/ PCS 1900	@power level #0 <300mA, Typical 220mA @power level #10, Typical 120mA @power level #15, Typical 113mA

Class 10 is default set when the module work at data translation mode, the module can also work at class 8 set by AT command. But the module power consumption will be added a little.

6.4.2 The current consumption of the SIM508 GPS part

To save more current consumption, we suggest the user to design their system in one of the two modes: 1. Power Down mode; 2.Push-To-Fix mode

6.4.2.1 Power down Mode

The circuit of this mode is shown in the figure:

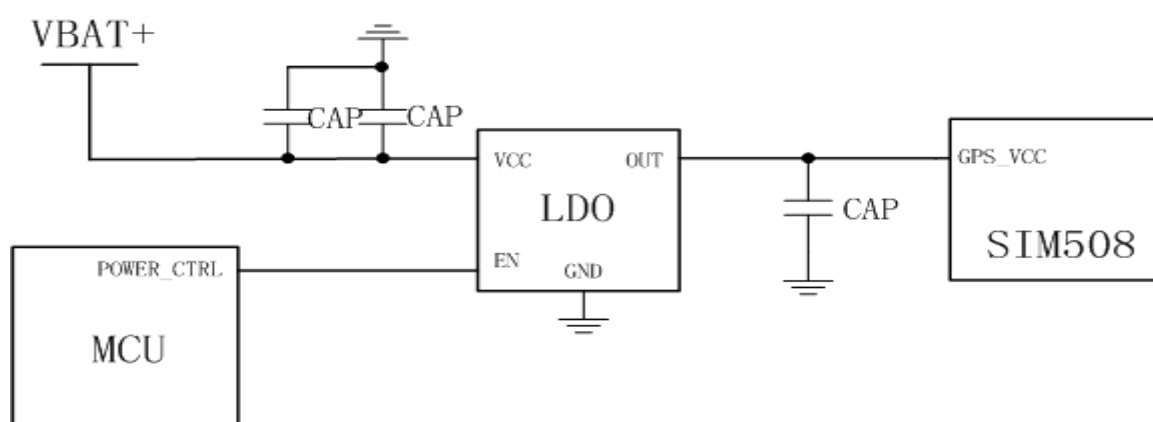

Figure 33: Power Down mode

When the user wants to save more current consumption of the GPS part, he can pull down the POWER_CTRL of the MCU to stop the LDO outputting. And this operation will cut off the power of the GPS part. *Note that the VRTC must be kept on.*

6.4.2.2 Push-To-Fix mode

The circuit of this mode is shown in figure (34)

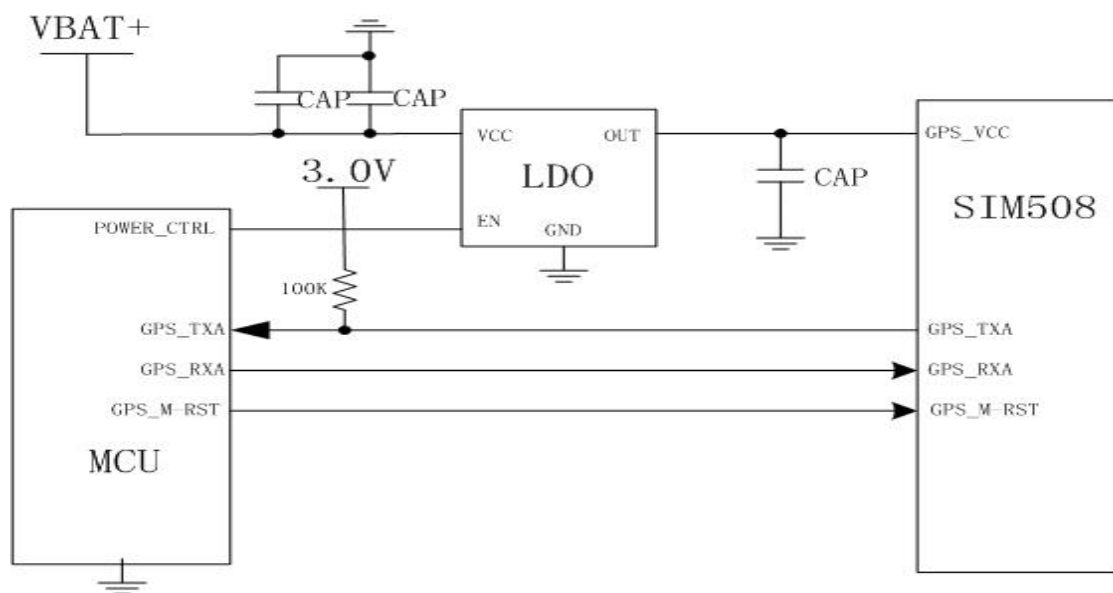

Figure 34: Push-To-Fix mode

The user can also save power by sending the “Push-To-Fix” command to the GPS part of the SIM508.

The Push-to-Fix mode puts the receiver into a background duty cycle mode that provides a periodic refresh of position, GPS time, ephemeris, and RTC calibration every 10 seconds to 2 hours. Typical PTF operation is illustrated in Figure (35).

The PTF period is 30 minutes by default but can be anywhere between 10 seconds and 2 hours. When the PTF mode is enabled, upon power on or a new PTF cycle, the receiver will stay on full power until the good navigation solution is computed. The stand-by state will follow for the remainder of the period. If it took 36 seconds to fix position and refresh ephemeris on the default period of 30 minutes, the receiver will sleep for the 29 minutes and 24 seconds. When the application needs a position report, it can toggle the GPS_M-RST pin to wake up the receiver. When the receiver wakes up, it can produce a valid position in the normal hot-start time.

Power consumption in the PTF mode

Again, a typical setting of 1800 seconds PTF interval is considered.

Assuming it takes 8 seconds to compute a good position since the start of a cycle, the average current and power consumption of each typical cycle is:

$$I_{avg} = (65 \text{ mA} * 8160 \text{ ms} + 1 \text{ mA} * 1791840 \text{ ms}) / 1800 \text{ seconds} = 1.290 \text{ mA}$$

$$P_{avg} = 3.3 \text{ V} * 1.290 \text{ mA} = 4.257 \text{ mW}$$

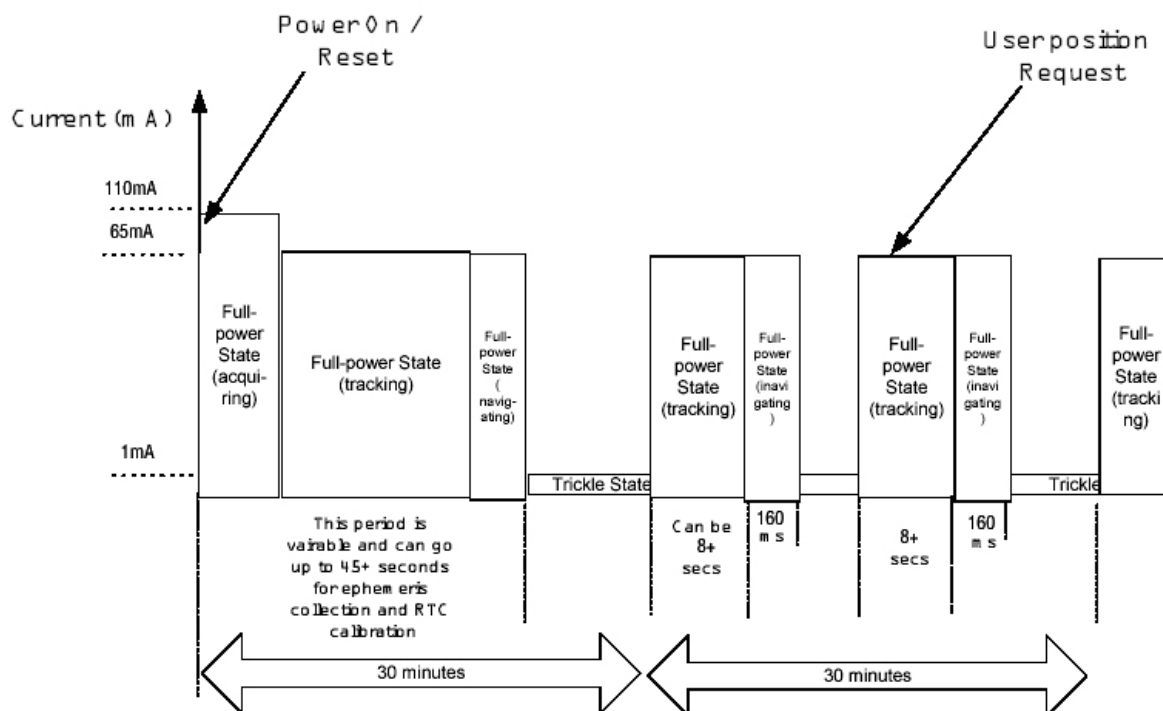

Figure 35: Power consumption in the PTF mode

Note:

When the user wants to use Power Down mode or Push-To-Fix mode, the RTC battery must be 2.5V+. If the RTC battery level is lower than 2.5V, the SIM508 module will not go into PTF mode.

6.5 Electrostatic discharge

Normally the module is designed inside customer terminal, so about Electrostatic Discharge (ESD) should be considered base on the requirement of terminal product. But for the module is protected against Electrostatic Discharge in conveyance and customer production, and some second level ESD protect design inside module.

The remaining ports are not special ESD protection in module, so the user should consider in the final product, and therefore, they are only protected according to the Human Body Model requirements.

Table 37: The ESD endure statue measured table (Temperature: 25°C, Humidity: 45%)

Part	Contact discharge	Air discharge
VBAT,GND	±4KV	±8KV
KBR0-4, DTR, RXD, TXD, RTS, DISP_DATA, DISP_CLK	±2KV	±4KV
Antenna port	±2KV	±4KV
Other port	±1KV	

7 Mechanics

This chapter describes the mechanical dimensions of SIM508.

7.1 Mechanical dimensions of SIM508

Following are SIM508 top view and side view. These show you Mechanical dimensions of SIM508.

www.DataSheet4U.com

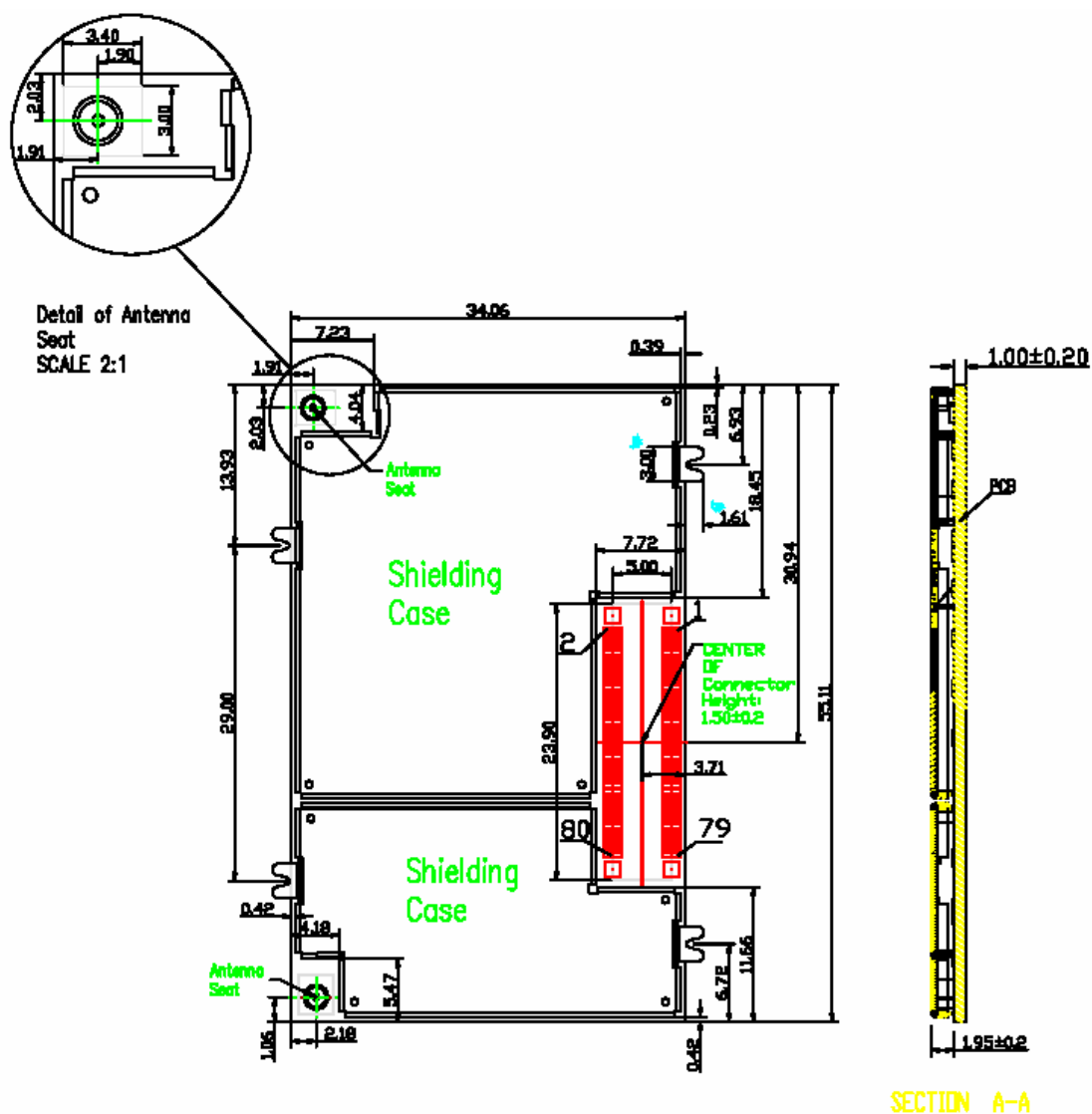

Figure 36: SIM508 TOP view and SIDE view

7.2 Mounting SIM508 onto the application platform

Use the connector 54363-0878 and four mounting pads fix the SIM508 onto customer platform.

7.3 Board-to-board connector

We recommend user adopt Molex Company's 54363-0878 type as the Board to board connector. These high density SMT connectors are designed for parallel PCB-to-PCB applications. They are ideal for use in VCRs, notebook PCs, cordless telephones, mobile phones, audio/visual and other telecommunications equipment where reduced size and weight are important. Following is parameter of 54363-0878. For more, you can login <http://www.molex.com>.

7.3.1 Mechanical dimensions of 54363-0878

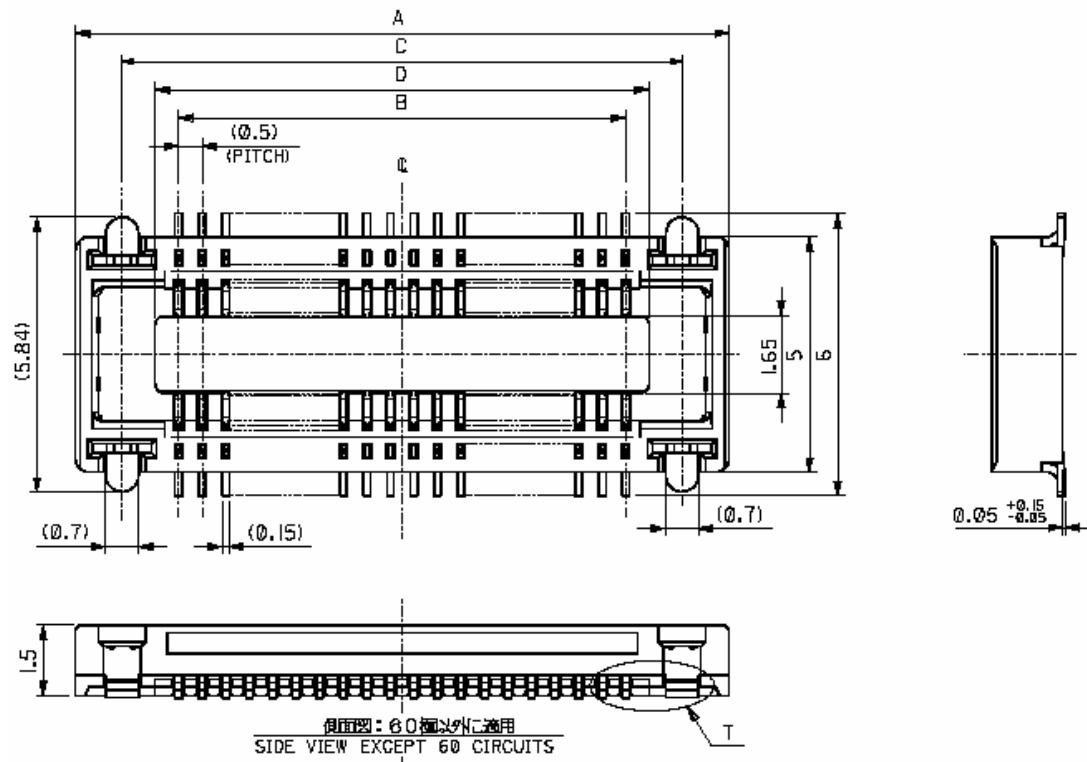

Figure 37: 54363-0878 board-to-board connector pin side

40.5	41.9	39.5	43.9	54363-1678	54363-1671	160	—
35.5	36.9	34.5	38.9	54363-1478	54363-1471	140	○
30.5	31.9	29.5	33.9	54363-1278	54363-1271	120	○
28	29.4	27	31.4	54363-1178	54363-1171	110	○
25.5	26.9	24.5	28.9	54363-1078	54363-1071	100	○
23	24.4	22	26.4	54363-0978	54363-0971	90	—
20.5	21.9	19.5	23.9	54363-0878	54363-0871	80	○
18	19.4	17	21.4	54363-0778	54363-0771	70	○
15.5	16.9	14.5	18.9	54363-0678	54363-0671	60	○
13	14.4	12	16.4	54363-0578	54363-0571	50	○
10.5	11.9	9.5	13.9	54363-0478	54363-0471	40	○
8	9.4	7	11.4	54363-0378	54363-0371	30	○
5.5	6.9	4.5	8.9	54363-0278	54363-0271	20	○
D	C	B	A	エンボス梱包品 EMBOSSED TAPE PACKAGING	製品番号 MATERIAL NO.	極数 CIRCUITS	量産対応 AVAILABLE
DIMENSIONS:						SHT	REV



Figure 38: board to board connector physical photo

Note: The connector 54363-0878 is used in socket side (SIM508 module) and 55201-0878 is used pin side (user side).

7.3.2 Adapter cabling

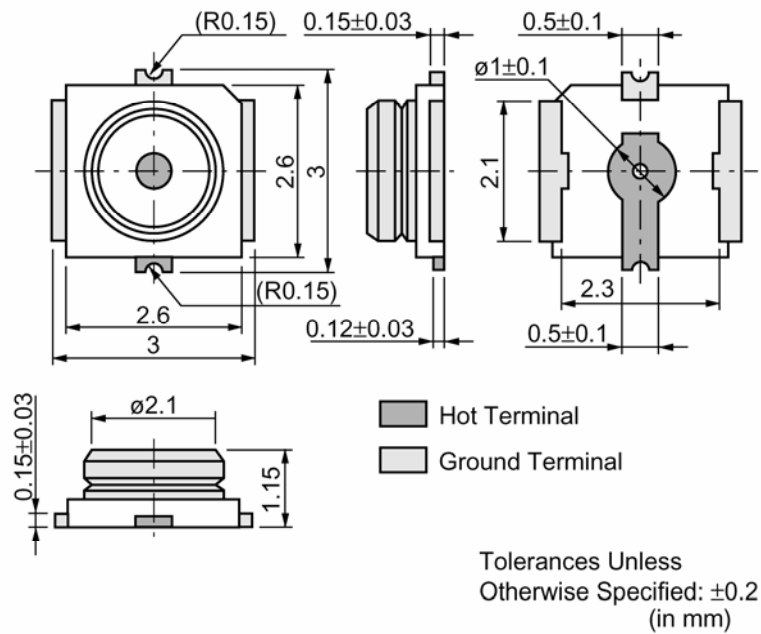

Figure 39: MM9329-2700B

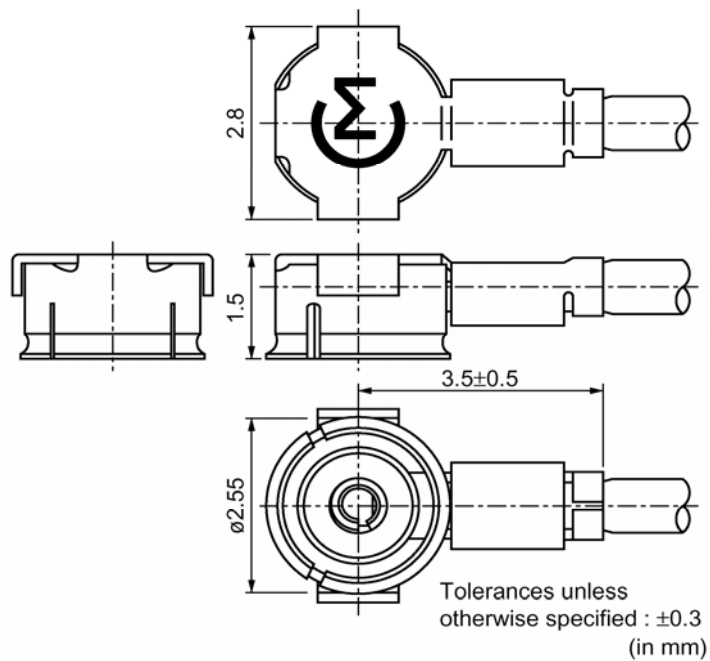

Figure 40: RF connector MXTK

For more information about the connector, please visit <http://www.murata.com/>

7.3.3 PIN assignment of board-to-board connector of SIM508

Table 38: Pin assignment of SIM 508

PIN NO.	PIN NAME	PIN NO.	PIN NAME
2	GND	1	VBAT
4	GND	3	VBAT
6	GND	5	VBAT
8	GND	7	VBAT
10	GND	9	VBAT
12	ADC0	11	VCHG
14	VRTC	13	TEMP_BAT
16	NETLIGHT	15	NC
18	KBC0	17	PWRKEY
20	KBC1	19	STATUS
22	KBC2	21	GPIO0
24	KBC3	23	BUZZER
26	KBC4	25	SIM_VDD
28	KBR0	27	SIM_RST
30	KBR1	29	SIM_DATA
32	KBR2	31	SIM_CLK
34	KBR3	33	SIM_PRESENCE
36	KBR4	35	GPIO1
38	DISP_CS	37	DCD
40	DISP_CLK	39	DTR
42	DISP_DATA	41	RXD
44	DISP_D/C	43	TXD
46	DISP_RST	45	RTS
48	DBG_RXD	47	CTS
50	DBG_TXD	49	RI
52	AGND	51	AGND
54	MIC1P	53	SPK1P
56	MIC1N	55	SPK1N
58	MIC2P	57	SPK2P
60	MIC2N	59	SPK2N
62	GPS_WAKEUP	61	GPS_TIMEMARK
64	GPS_BOOTSEL	63	GPS_FREQ_XFER
66	GPS_M-RST	65	GPS_TIMERSYNC
68	GPS_TXB	67	NC
70	GPS_RXB	69	NC
72	GPS_TXA	71	NC
74	GPS_RXA	73	GPS_GPIO13
76	GPS_VCC_RF	75	GPS_GPIO14
78	GPS_VANT	77	GPS_VRTC
80	GPS_VCC	79	GPS_VCC

The following figure is a top-view of SIM508 module. With the indication of Pin 1, 2, 79 and 80.

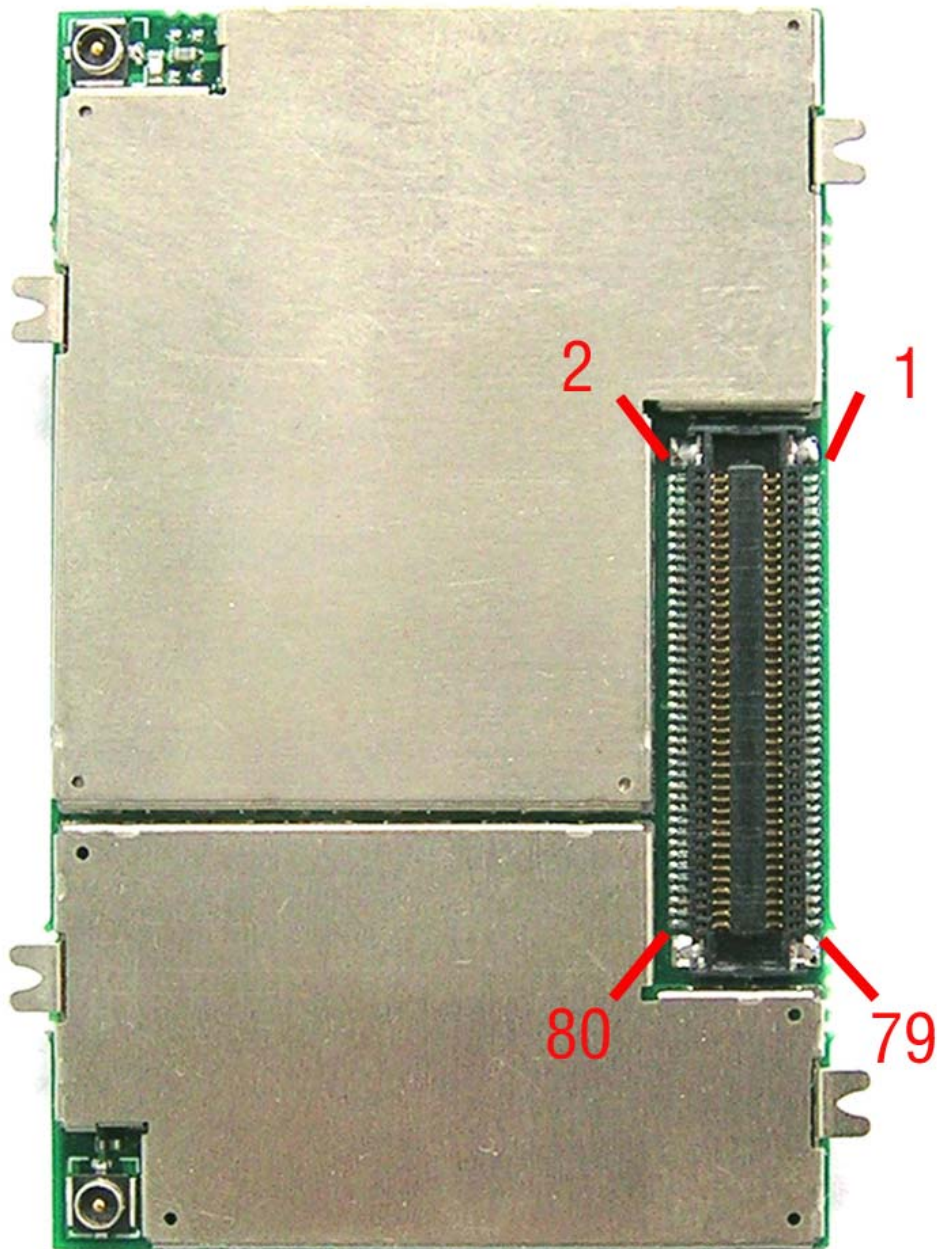

Figure 41: physical SIM508

