

**PERIPHERAL DRIVERS FOR  
 HIGH-VOLTAGE HIGH-CURRENT DRIVER  
 APPLICATIONS**

- Characterized for Use to 300 mA
- High-Voltage Outputs
- No Output Latch-Up at 55 V (After Conducting 300 mA)
- Medium-Speed Switching
- Circuit Flexibility for Varied Applications and Choice of Logic Function
- TTL-Compatible Diode-Clamped Inputs
- Standard Supply Voltages
- Plastic DIP (P) With Copper Lead Frame Provides Cooler Operation and Improved Reliability

**D OR P PACKAGE  
 (TOP VIEW)**



**SUMMARY OF SERIES SN75471**

DEVICE	LOGIC OF COMPLETE CIRCUIT	PACKAGES
SN75471	AND	D, P
SN75472	NAND	D, P
SN75473	OR	D, P

**description**

Series SN75471 dual peripheral drivers are functionally interchangeable with series SN75451B and series SN75461 peripheral drivers, but are designed for use in systems that require higher breakdown voltages than either of those series can provide at the expense of slightly slower switching speeds than series 75451B (limits are the same as series SN75461). Typical applications include high-speed logic buffers, power drivers, relay drivers, lamp drivers, MOS drivers, line drivers, and memory drivers.

The SN75471, SN75472, and SN75473 are dual peripheral AND, NAND, and OR drivers, respectively, (assuming positive logic), with the output of the logic gates internally connected to the bases of the npn output transistors.

Series SN75471 drivers are characterized for operation from 0°C to 70°C.



# SN75471 THRU SN75473 DUAL PERIPHERAL DRIVERS

SLRS024 – DECEMBER 1976 – REVISED MAY 1990

## absolute maximum ratings over operating free-air temperature range (unless otherwise noted)

Supply voltage, $V_{CC}$ (see Note 1)	7 V
Input voltage, $V_I$	5.5 V
Inter-emitter voltage (see Note 2)	5.5 V
Off-state output voltage, $V_O$	70 V
Continuous collector or output current (see Note 3)	400 mA
Peak collector or output current ( $t_w \leq 10$ ms, duty cycle $\leq 50\%$ , see Note 3)	500 mA
Continuous total power dissipation	See Dissipation Rating Table
Operating free-air temperature range, $T_A$	0°C to 70°C
Storage temperature range, $T_{stg}$	-65°C to 150°C
Lead temperature 1,6 mm (1/16 inch) from case for 10 seconds	260°C

- NOTES: 1. Voltage values are with respect to the network GND, unless otherwise specified.  
 2. This is the voltage between two emitters, A and B.  
 3. Both halves of these dual circuits may conduct rated current simultaneously; however, power dissipation averaged over a short time interval must fall within the continuous dissipation rating.

DISSIPATION RATING TABLE

PACKAGE	$T_A \leq 25^\circ\text{C}$ POWER RATING	DERATING FACTOR ABOVE $T_A = 25^\circ\text{C}$	$T_A = 70^\circ\text{C}$ POWER RATING
D	725 mW	5.8 mW/°C	464 mW
P	1000 mW	8.0 mW/°C	640 mW

## recommended operating conditions

	MIN	NOM	MAX	UNIT
Supply voltage, $V_{CC}$	4.75	5	5.25	V
High-level input voltage, $V_{IH}$	2			V
Low-level input voltage, $V_{IL}$			0.8	V
Operating free-air temperature, $T_A$	0		70	°C

# SN75471 THRU SN75473 DUAL PERIPHERAL DRIVERS

SLRS024 – DECEMBER 1976 – REVISED MAY 1990

## logic symbol†



† This symbol is in accordance with ANSI/IEEE Std 91-1984 and IEC Publication 617-12.

## logic diagram (positive logic)

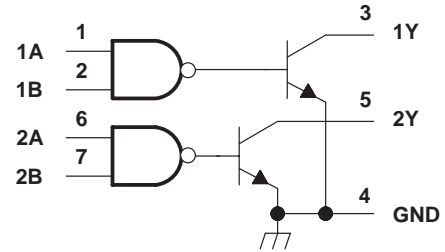

SN75471 FUNCTION TABLE  
(each driver)

A	B	Y
L	L	L (on state)
L	H	L (on state)
H	L	L (on state)
H	H	H (off state)

positive logic:  
 $Y = AB$  or  $\overline{A + B}$

SN75471 schematic (each driver)

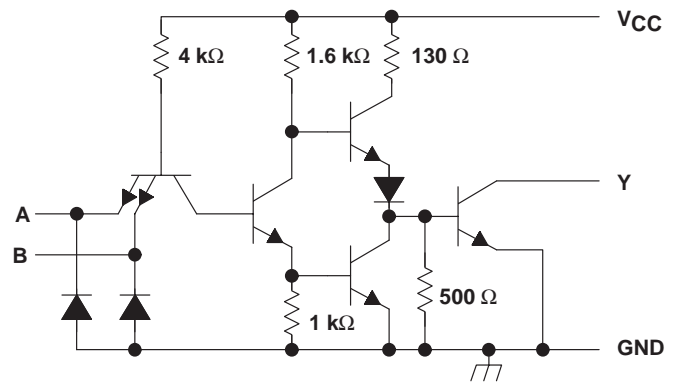

Resistor values shown are nominal.

## electrical characteristics over recommended operating free-air temperature range

PARAMETER	TEST CONDITIONS	SN75471			UNIT
		MIN	TYP‡	MAX	
$V_{IK}$ Input clamp voltage	$V_{CC} = 4.75$ V, $I_I = -12$ mA	-1.2	-1.5		V
$I_{OH}$ High-level output current	$V_{CC} = 4.75$ V, $V_{IH} = 2$ V, $V_{OH} = 70$ V			100	μA
$V_{OL}$ Low-level output voltage	$V_{CC} = 4.75$ V, $V_{IL} = 0.8$ V, $I_{OL} = 100$ mA	0.25	0.4		V
	$V_{CC} = 4.75$ V, $V_{IL} = 0.8$ V, $I_{OL} = 300$ mA	0.5	0.7		
$I_I$ Input current at maximum input voltage	$V_{CC} = 5.25$ V, $V_I = 5.5$ V			1	mA
$I_{IH}$ High-level input current	$V_{CC} = 5.25$ V, $V_I = 2.4$ V			40	μA
$I_{IL}$ Low-level input current	$V_{CC} = 5.25$ V, $V_I = 0.4$ V	-1	-1.6		mA
$I_{CCH}$ Supply current, outputs high	$V_{CC} = 5.25$ V, $V_I = 5$ V	7	11		mA
$I_{CCL}$ Supply current, outputs low	$V_{CC} = 5.25$ V, $V_I = 0$	52	65		mA

‡ All typical values are at  $V_{CC} = 5$  V,  $T_A = 25^\circ\text{C}$ .

## switching characteristics, $V_{CC} = 5$ V, $T_A = 25^\circ\text{C}$

PARAMETER	TEST CONDITIONS	SN75471			UNIT
		MIN	TYP	MAX	
$t_{PLH}$ Propagation delay time, low-to-high-level output	$I_O \approx 200$ mA, $C_L = 15$ pF, $R_L = 50$ Ω, See Figure 1		30	55	ns
$t_{PHL}$ Propagation delay time, high-to-low-level output			25	40	
$t_{TLH}$ Transition time, low-to-high-level output			8	20	
$t_{THL}$ Transition time, high-to-low-level output			10	20	
$V_{OH}$ High-level output voltage after switching	$V_S = 55$ V, See Figure 2, $I_O \approx 300$ mA,	$V_S - 18$			mV

# SN75471 THRU SN75473 DUAL PERIPHERAL DRIVERS

SLRS024 – DECEMBER 1976 – REVISED MAY 1990

## logic symbol†



† This symbol is in accordance with ANSI/IEEE Std 91-1984 and IEC Publication 617-12.

## logic diagram (positive logic)

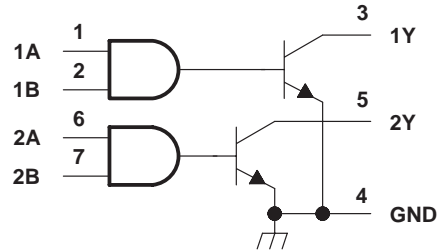

SN75472 FUNCTION TABLE  
(each driver)

A	B	Y
L	L	H (off state)
L	H	H (off state)
H	L	H (off state)
H	H	L (on state)

positive logic:  
 $Y = AB \text{ or } \overline{A + B}$

SN75472 schematic (each driver)

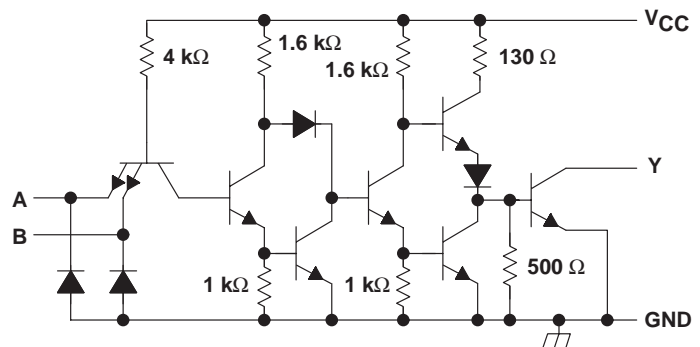

Resistor values shown are nominal.

## electrical characteristics over recommended operating free-air temperature range

PARAMETER	TEST CONDITIONS	SN75472			UNIT
		MIN	TYP‡	MAX	
V <sub>IK</sub> Input clamp voltage	V <sub>CC</sub> = 4.75 V, I <sub>I</sub> = -12 mA	-1.2	-1.5		V
I <sub>OH</sub> High-level output current	V <sub>CC</sub> = 4.75 V, V <sub>IH</sub> = 2 V, V <sub>OH</sub> = 70 V			100	μA
V <sub>OL</sub> Low-level output voltage	V <sub>CC</sub> = 4.75 V, V <sub>IL</sub> = 0.8 V, I <sub>OL</sub> = 100 mA	0.25	0.4		V
	V <sub>CC</sub> = 4.75 V, V <sub>IL</sub> = 0.8 V, I <sub>OL</sub> = 300 mA	0.5	0.7		
I <sub>I</sub> Input current at maximum input voltage	V <sub>CC</sub> = 5.25 V, V <sub>I</sub> = 5.5 V			1	mA
I <sub>IH</sub> High-level input current	V <sub>CC</sub> = 5.25 V, V <sub>I</sub> = 2.4 V			40	μA
I <sub>IL</sub> Low-level input current	V <sub>CC</sub> = 5.25 V, V <sub>I</sub> = 0.4 V	-1	-1.6		mA
I <sub>CCH</sub> Supply current, outputs high	V <sub>CC</sub> = 5.25 V, V <sub>I</sub> = 5 V		13	17	mA
I <sub>CCL</sub> Supply current, outputs low	V <sub>CC</sub> = 5.25 V, V <sub>I</sub> = 0		61	76	mA

‡ All typical values are at V<sub>CC</sub> = 5 V, T<sub>A</sub> = 25°C.

## switching characteristics, V<sub>CC</sub> = 5 V, T<sub>A</sub> = 25°C

PARAMETER	TEST CONDITIONS	SN75472			UNIT
		MIN	TYP	MAX	
t <sub>PLH</sub> Propagation delay time, low-to-high-level output	I <sub>O</sub> ≈ 200 mA, C <sub>L</sub> = 15 pF, R <sub>L</sub> = 50 Ω, See Figure 1		45	65	ns
t <sub>PHL</sub> Propagation delay time, high-to-low-level output			30	50	
t <sub>TLH</sub> Transition time, low-to-high-level output			13	25	
t <sub>THL</sub> Transition time, high-to-low-level output			10	20	
V <sub>OH</sub> High-level output voltage after switching	V <sub>S</sub> = 55 V, I <sub>O</sub> ≈ 300 mA, See Figure 2	V <sub>S</sub> - 18			mV

# SN75471 THRU SN75473 DUAL PERIPHERAL DRIVERS

SLRS024 – DECEMBER 1976 – REVISED MAY 1990

## logic symbol†

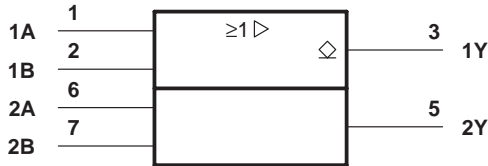

† This symbol is in accordance with ANSI/IEEE Std 91-1984 and IEC Publication 617-12.

## logic diagram (positive logic)

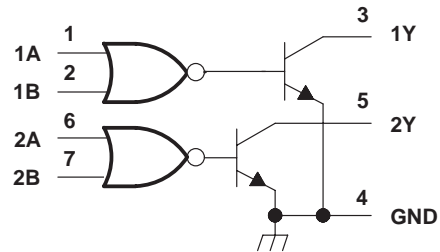

FUNCTION TABLE  
(each driver)

A	B	Y
L	L	L (on state)
L	H	H (off state)
H	L	H (off state)
H	H	H (off state)

positive logic:  
 $Y = A + B$  or  $\bar{A}\bar{B}$

## schematic (each driver)

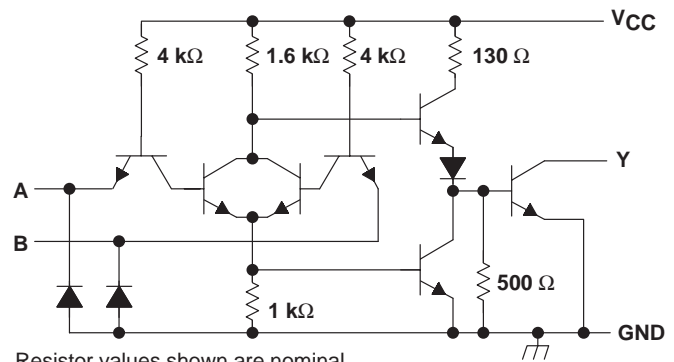

Resistor values shown are nominal.

## electrical characteristics over recommended operating free-air temperature range

PARAMETER	TEST CONDITIONS	SN75473			UNIT
		MIN	TYP‡	MAX	
$V_{IK}$ Input clamp voltage	$V_{CC} = 4.75 \text{ V}$ , $I_I = -12 \text{ mA}$	-1.2	-1.5		V
$I_{OH}$ High-level output current	$V_{CC} = 4.75 \text{ V}$ , $V_{IH} = 2 \text{ V}$ , $V_{OH} = 70 \text{ V}$			100	$\mu\text{A}$
$V_{OL}$ Low-level output voltage	$V_{CC} = 4.75 \text{ V}$ , $V_{IL} = 0.8 \text{ V}$ , $I_{OL} = 100 \text{ mA}$	0.25	0.4		V
	$V_{CC} = 4.75 \text{ V}$ , $V_{IL} = 0.8 \text{ V}$ , $I_{OL} = 300 \text{ mA}$	0.5	0.7		
$I_I$ Input current at maximum input voltage	$V_{CC} = 5.25 \text{ V}$ , $V_I = 5.5 \text{ V}$			1	mA
$I_{IH}$ High-level input current	$V_{CC} = 5.25 \text{ V}$ , $V_I = 2.4 \text{ V}$			40	$\mu\text{A}$
$I_{IL}$ Low-level input current	$V_{CC} = 5.25 \text{ V}$ , $V_I = 0.4 \text{ V}$	-1	-1.6		mA
$I_{CCH}$ Supply current, outputs high	$V_{CC} = 5.25 \text{ V}$ , $V_I = 5 \text{ V}$	8	11		mA
$I_{CCL}$ Supply current, outputs low	$V_{CC} = 5.25 \text{ V}$ , $V_I = 0$	58	76		mA

‡ All typical values are at  $V_{CC} = 5 \text{ V}$ ,  $T_A = 25^\circ\text{C}$ .

## switching characteristics, $V_{CC} = 5 \text{ V}$ , $T_A = 25^\circ\text{C}$

PARAMETER	TEST CONDITIONS	SN75473			UNIT
		MIN	TYP	MAX	
$t_{PLH}$ Propagation delay time, low-to-high-level output	$I_O \approx 200 \text{ mA}$ , $C_L = 15 \text{ pF}$ , $R_L = 50 \Omega$ , See Figure 1		30	55	ns
$t_{PHL}$ Propagation delay time, high-to-low-level output			25	40	
$t_{TLH}$ Transition time, low-to-high-level output			8	25	
$t_{THL}$ Transition time, high-to-low-level output			10	25	
$V_{OH}$ High-level output voltage after switching	$V_S = 55 \text{ V}$ , See Figure 2	$I_O \approx 300 \text{ mA}$ ,	$V_S - 18$		mV

# SN75471 THRU SN75473 DUAL PERIPHERAL DRIVERS

SLRS024 – DECEMBER 1976 – REVISED MAY 1990

## PARAMETER MEASUREMENT INFORMATION

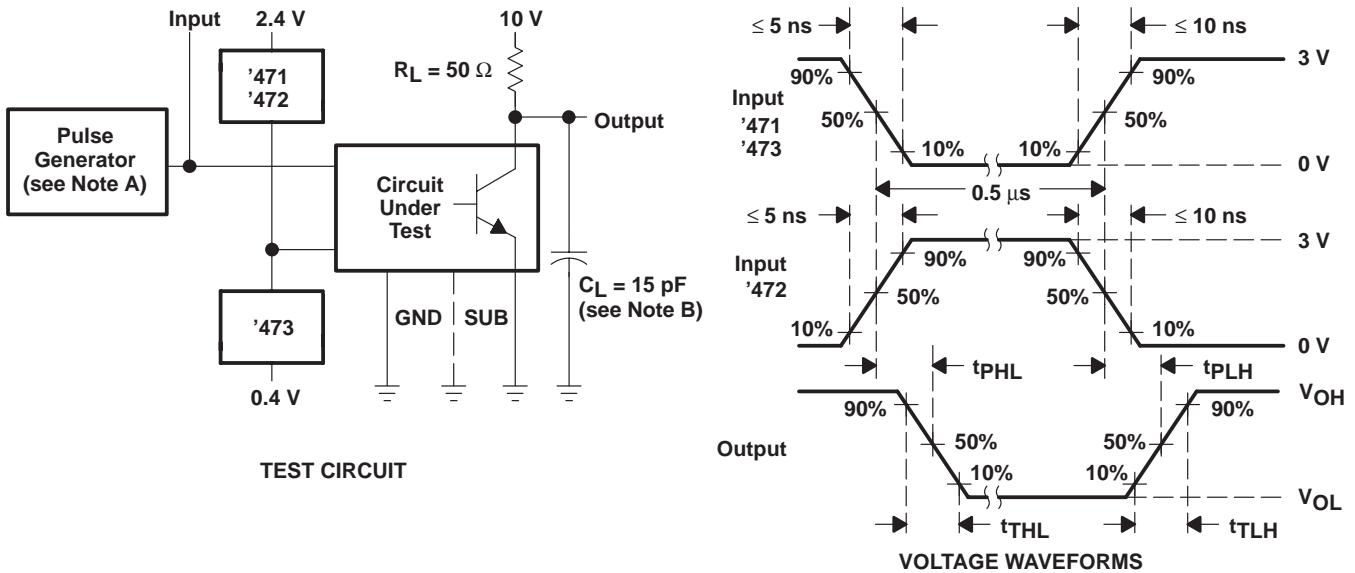

NOTES: A. The pulse generator has the following characteristics:  $\text{PRR} \leq 1 \text{ MHz}$ ,  $Z_O \approx 50 \Omega$ .  
B.  $C_L$  includes probe and jig capacitance.

Figure 1. Switching Times

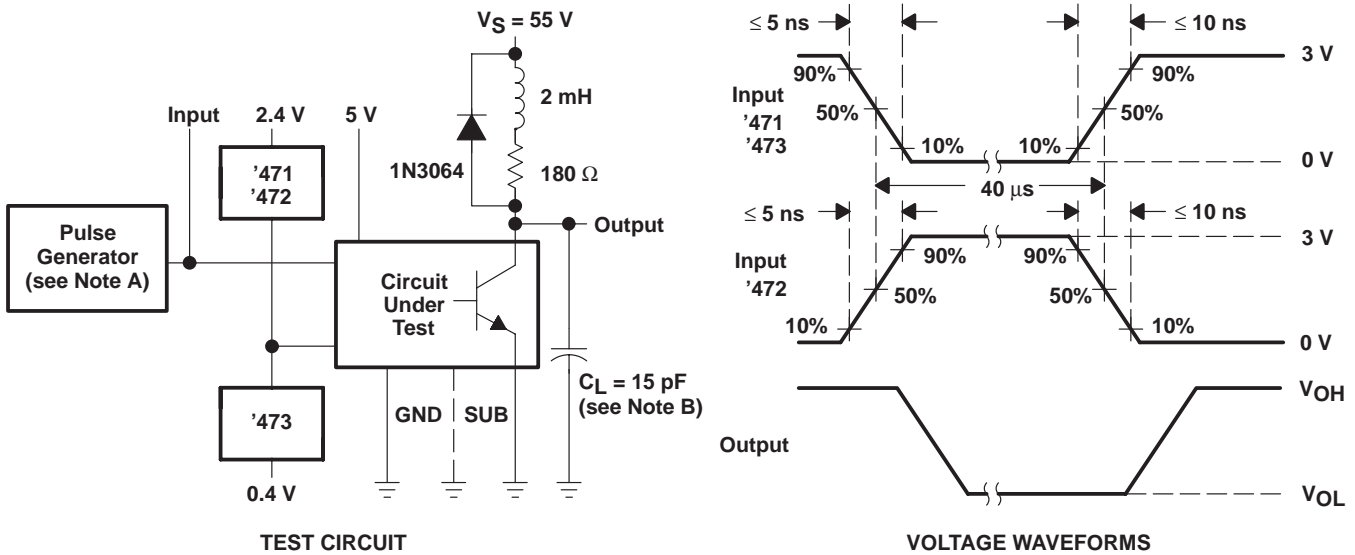

NOTES: A. The pulse generator has the following characteristics:  $\text{PRR} \leq 12.5 \text{ kHz}$ ,  $Z_O \approx 50 \Omega$ .  
B.  $C_L$  includes probe and jig capacitance.

Figure 2. Latch-Up Test

## **IMPORTANT NOTICE**

Texas Instruments and its subsidiaries (TI) reserve the right to make changes to their products or to discontinue any product or service without notice, and advise customers to obtain the latest version of relevant information to verify, before placing orders, that information being relied on is current and complete. All products are sold subject to the terms and conditions of sale supplied at the time of order acknowledgement, including those pertaining to warranty, patent infringement, and limitation of liability.

TI warrants performance of its semiconductor products to the specifications applicable at the time of sale in accordance with TI's standard warranty. Testing and other quality control techniques are utilized to the extent TI deems necessary to support this warranty. Specific testing of all parameters of each device is not necessarily performed, except those mandated by government requirements.

CERTAIN APPLICATIONS USING SEMICONDUCTOR PRODUCTS MAY INVOLVE POTENTIAL RISKS OF DEATH, PERSONAL INJURY, OR SEVERE PROPERTY OR ENVIRONMENTAL DAMAGE ("CRITICAL APPLICATIONS"). TI SEMICONDUCTOR PRODUCTS ARE NOT DESIGNED, AUTHORIZED, OR WARRANTED TO BE SUITABLE FOR USE IN LIFE-SUPPORT DEVICES OR SYSTEMS OR OTHER CRITICAL APPLICATIONS. INCLUSION OF TI PRODUCTS IN SUCH APPLICATIONS IS UNDERSTOOD TO BE FULLY AT THE CUSTOMER'S RISK.

In order to minimize risks associated with the customer's applications, adequate design and operating safeguards must be provided by the customer to minimize inherent or procedural hazards.

TI assumes no liability for applications assistance or customer product design. TI does not warrant or represent that any license, either express or implied, is granted under any patent right, copyright, mask work right, or other intellectual property right of TI covering or relating to any combination, machine, or process in which such semiconductor products or services might be or are used. TI's publication of information regarding any third party's products or services does not constitute TI's approval, warranty or endorsement thereof.