

Ordering number : ENN5792A

Monolithic Digital IC



LB1991V

Three-Phase Brushless Motor Driver for Portable VCR Capstan Motors

Overview

The LB1991V is a 3-phase brushless motor driver IC that is optimal for driving the capstan motor in portable VCR products.

Functions

- 3-phase full-wave voltage drive technique (120° voltage-linear technique)
- Torque ripple correction circuit (overlap correction)
- Speed control technique based on motor voltage and current control.
- Built-in FG comparators
- Built-in thermal shutdown circuit

Package Dimensions

unit: mm

3175A-SSOP24

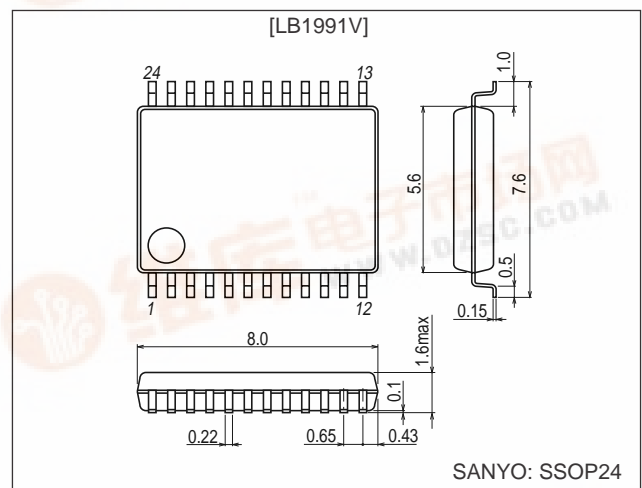

Specifications

Absolute Maximum Ratings at Ta = 25°C

Parameter	Symbol	Conditions	Ratings	Unit
Maximum supply voltage	V _{CC1} max		10	V
	V _{CC2} max		11	V
	V _S max		11	V
Applied output voltage	V _O max		V _S + 2	V
Maximum output current	I _O max		1.0	A
Allowable power dissipation	P _d max	Independent IC	440	mW
Operating temperature	T _{opr}		-20 to +75	°C
Storage temperature	T _{stg}		-55 to +150	°C

- Any and all SANYO products described or contained herein do not have specifications that can handle applications that require extremely high levels of reliability, such as life-support systems, aircraft's control systems, or other applications whose failure can be reasonably expected to result in serious physical and/or material damage. Consult with your SANYO representative nearest you before using any SANYO products described or contained herein in such applications.
- SANYO assumes no responsibility for equipment failures that result from using products at values that exceed, even momentarily, rated values (such as maximum ratings, operating condition ranges, or other parameters) listed in products specifications of any and all SANYO products described or contained herein.



LB1991V

Allowable Operating Ranges at Ta = 25°C

Parameter	Symbol	Conditions	Ratings	Unit
Supply voltage	V _{CC1}	V _{CC1} ≤ V _{CC2}	2.7 to 6.0	V
	V _{CC2}		3.5 to 9.0	V
	V _S		Up to V _{CC2}	V
Hall input amplitude	V _{HALL}	Between Hall effect element inputs	±20 to ±80	mVp-p

Electrical Characteristics at Ta = 25°C, V_{CC1} = 3 V, V_{CC2} = 4.75 V, V_S = 1.5 V

Parameter	Symbol	Conditions	Ratings			Unit
			min	typ	max	
[Supply Current]						
V _{CC1} current drain	I _{CC1}	I _{OUT} = 100 mA		3	5	mA
V _{CC2} current drain	I _{CC2}	I _{OUT} = 100 mA		7.0	10.0	mA
V _{CC1} quiescent current	I _{CC1Q}	V _{STBY} = 0 V		1.5	3.0	mA
V _{CC2} quiescent current	I _{CC2Q}	V _{STBY} = 0 V			100	µA
V _S quiescent current	I _{SQ}	V _{STBY} = 0 V		75	100	µA
[VX1]						
High side residual voltage	V _{XH1}	I _{OUT} = 0.2 A	0.15	0.22	0.29	V
Low side residual voltage	V _{XL1}	I _{OUT} = 0.2 A	0.15	0.20	0.25	V
[VX2]						
High side residual voltage	V _{XH2}	I _{OUT} = 0.5 A		0.25	0.40	V
Low side residual voltage	V _{XL2}	I _{OUT} = 0.5 A		0.25	0.40	V
Output saturation voltage	V _{O(sat)}	I _{OUT} = 0.8 A, Sink + Source			1.4	V
Overlap	O.L	R _L = 39 Ω × 3, R _{angle} = 20 kΩ *2	73	80	87	%
High/low overlap difference	ΔO.L	(Average upper side overlap) – (Average lower side overlap) *2	-8		+8	%
[Hall Amplifiers]						
Input offset voltage	V _{HOFF}	*1	-5		+5	mV
Common-mode input voltage range	V _{HCM}	R _{angle} = 20 kΩ	0.95		2.1	V
I/O voltage gain	V _{GVH}	R _{angle} = 20 kΩ	25.5	28.5	31.5	dB
[Standby Pin]						
High-level voltage	V _{STH}		2.5			V
Low-level voltage	V _{STL}				0.4	V
Input current	I _{STIN}	V _{STBY} = 3 V		25	40	µA
Leakage current	I _{STLK}	V _{STBY} = 0 V			-30	µA
[FRC Pin]						
High-level voltage	V _{FRCH}		2.5			V
Low-level voltage	V _{FRCL}				0.4	V
Input current	I _{FRGIN}	V _{FRC} = 3 V		20	30	µA
Leakage current	I _{FRCLK}	V _{FRC} = 0 V			-30	µA
[VH]						
Hall supply voltage	V _{HALL}	I _H = 5 mA, V _H (+) – V _H (-)	0.85	0.95	1.05	V
(-) pin voltage	V _{H(-)}	I _H = 5 mA	0.81	0.88	0.95	V
[FG Comparator]						
Input offset voltage	V _{FGOFF}		-3		+3	mV
Input bias voltage	I _{bFG}	V _{FGIN+} = V _{FGIN-} = 1.5 V			500	nA
Input bias current offset	ΔI _{bFG}	V _{FGIN+} = V _{FGIN-} = 1.5 V	-100		+100	nA
Common-mode input voltage range	V _{FGCM}		1.2		2.5	V
Output high-level voltage	V _{FGOH}	At the internal pull-up resistors	2.8			V
Output low-level voltage	V _{FGOL}	At the internal pull-up resistors			0.2	V
Voltage gain	V _{GFG}	*1		100		dB
Output current (sink)	I _{FGOS}	For the output pin low level			5	mA
[TSD]						
TSD operating temperature	T-TSD	Design target value *1		180		°C
TSD temperature hysteresis	ΔTSD	Design target value *1		20		°C

Notes: 1. Items specified as design target values in the conditions column are not tested.
2. The standard for overlap is the value as measured.

LB1991V

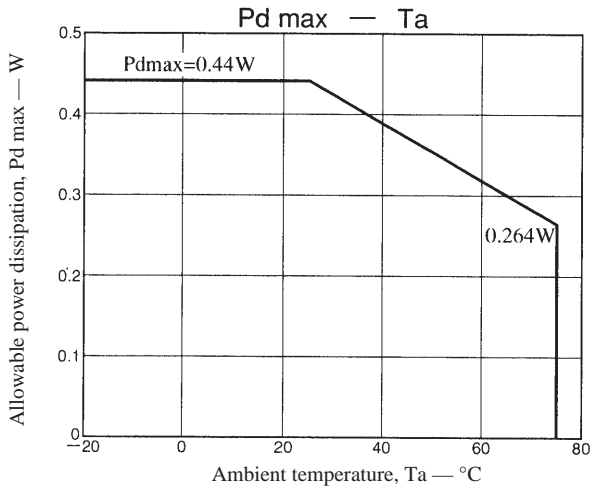

Pin Assignment

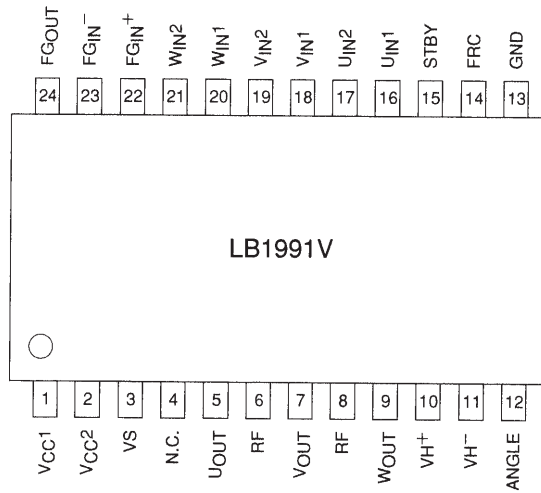

Top view

A09824

Truth Table

	Source phase → Sink phase	Hall input			FRC
1	V → W	H	H	L	H
	W → V				L
2	U → W	H	L	L	H
	W → U				L
3	U → V	H	L	H	H
	V → U				L
4	W → V	L	L	H	H
	V → W				L
5	W → U	L	H	H	H
	U → W				L
6	V → U	L	H	L	H
	U → V				L

Note: The "H" entries in the FRC column indicate a voltage of 2.50 V or higher, and the "L" entries indicate a voltage of 0.4 V or lower. (When VCC1 is 3 V.)
 At the Hall inputs, for each phase a high-level input is the state where the (+) input is 0.02 V or higher than the (-) input. Similarly, a low-level input is the state where the (+) input is 0.02 V or lower than the (-) input.

LB1991V

Pin Functions

Pin No.	Pin	Equivalent circuit	Pin function
1	V _{CC1}	Supply voltage for all circuits other than the IC internal output block and the amplitude control block.	
2	V _{CC2}	Supply voltage for the IC internal output control block and the amplitude control block.	
3	V _S	Motor drive power supply. The voltage applied to this pin must not exceed V _{CC2} .	
5	U _{OUT}	U phase output	
7	V _{OUT}	V phase output (These outputs include built-in spark killer diodes.)	
9	W _{OUT}	W phase output	
6, 8	R _f	Ground for the output power transistors	
10	VH ⁺	Hall element bias voltage supply A voltage that is typically 0.95 V is generated between the VH ⁺ and VH ⁻ pins. (When I _H is 5 mA.)	
11	VH ⁻		
13	GND	Ground for circuits other than the output transistor The R _f pin potential is the lowest output transistor potential.	
14	FRC	Forward/reverse selection. Applications can select motor forward or reverse direction rotation using this pin. (This pin has hysteresis characteristics.)	
15	STBY	Selects the bias supply for all circuits other than the FG comparators. The bias supply is cut when this pin is set to the low level.	
16	U _{IN1}	U phase Hall element input	
17	U _{IN2}	The logic high level is the state where the IN ⁺ voltage is greater than the IN ⁻ voltage.	
18	V _{IN1}	V phase Hall element input	
19	V _{IN2}	The logic high level is the state where the IN ⁺ voltage is greater than the IN ⁻ voltage.	
20	W _{IN1}	W phase Hall element input	
21	W _{IN2}	The logic high level is the state where the IN ⁺ voltage is greater than the IN ⁻ voltage.	
12	ANGLE	Hall input/output gain control. The gain is controlled by the resistor connected between this pin and ground.	
22	FG _{IN+}	FG comparator noninverting inputs. There is no internally applied bias.	
23	FG _{IN-}	FG comparator inverting inputs. There is no internally applied bias.	
24	FG _{OUT}	FG comparator outputs. There is an internal 20-kΩ resistor load.	

Overlap Generation and Calculation Method

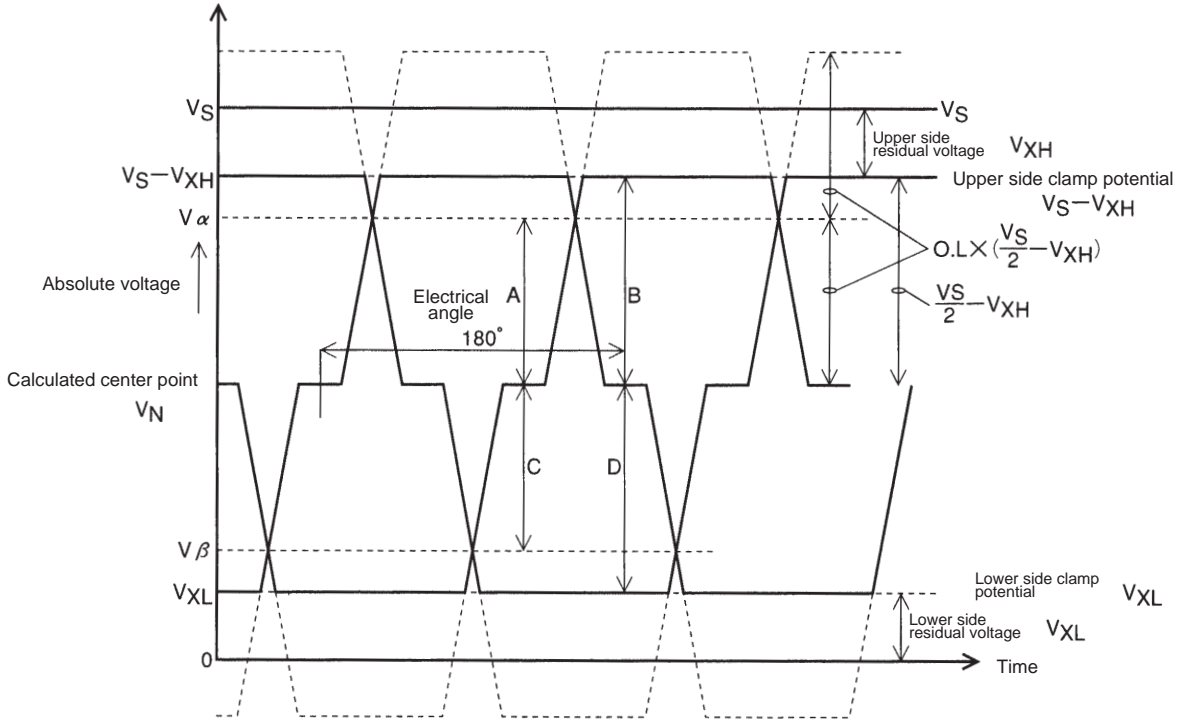

A09831

[Overlap Generation]

Since the voltage generated in the amplitude control block is, taking the center point as the reference, $2 \times \langle \text{overlap} \rangle \times (1/2 V_S - V_X)$ on one side, the intersection point of the waveform will be $\langle \text{overlap} \rangle \times (1/2 V_S - V_X)$ from the center point.

To clamp that waveform at $(1/2 V_S - V_X)$ referenced to the center point the overlap must be:

$$A/B \times 100 = \langle \text{overlap} \rangle \times 100 (\%)$$

[Overlap Calculation]

• Upper side overlap

$$\text{Calculated center point: } V_N = \frac{(V_S - V_{XH} - V_{XL})}{2} + V_{XL} = \frac{(V_S - V_{XH} + V_{XL})}{2}$$

Since $A = V_\alpha - V_N$, $B = V_S - V_{XH} - V_N$, the upper side overlap will be:

$$\langle \text{overlap} \rangle = \frac{A}{B} = \frac{V_\alpha - ((V_S - V_{XH} + V_{XL})/2)}{V_S - V_{XH} - ((V_S - V_{XH} + V_{XL})/2)} \times 100 (\%)$$

Which can be calculated as:

$$= \frac{2V_\alpha - (V_S - V_{XH}) - V_{XL}}{(V_S - V_{XH}) - V_{XL}} \times 100 (\%)$$

• Lower side overlap

Since $C = V_N - V_\beta$, and $D = V_N - V_{XL}$, the lower side overlap will be:

$$\langle \text{overlap} \rangle = \frac{C}{D} = \frac{((V_S - V_{XH} + V_{XL})/2) - V_\beta}{((V_S - V_{XH} + V_{XL})/2) - V_{XL}} \times 100$$

Which can be calculated as:

$$= \frac{(V_S - V_{XH}) - V_{XL} - 2V_\beta}{(V_S - V_{XH}) - V_{XL}} \times 100 (\%)$$

LB1991V

Test Circuit

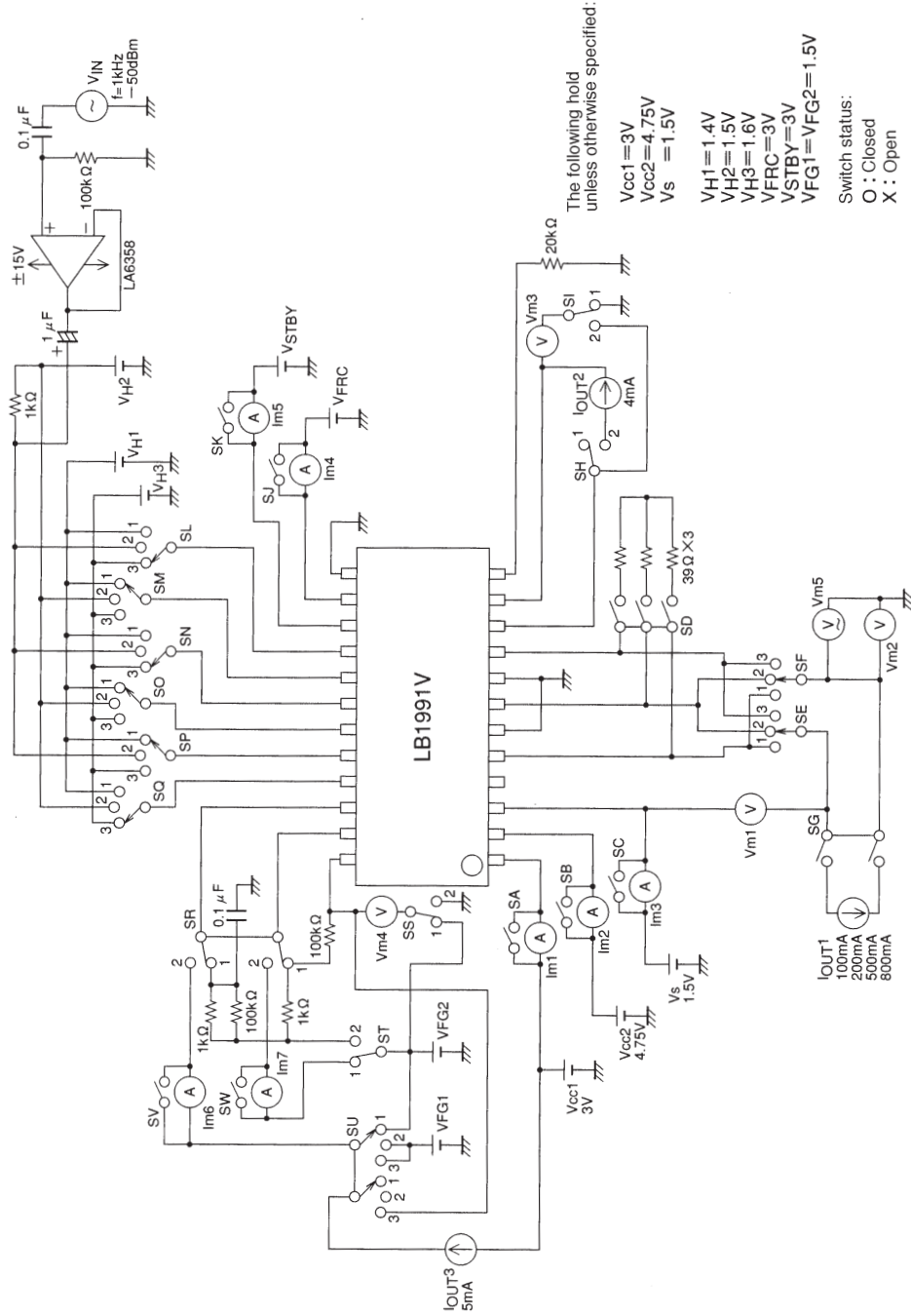

- Specifications of any and all SANYO products described or contained herein stipulate the performance, characteristics, and functions of the described products in the independent state, and are not guarantees of the performance, characteristics, and functions of the described products as mounted in the customer's products or equipment. To verify symptoms and states that cannot be evaluated in an independent device, the customer should always evaluate and test devices mounted in the customer's products or equipment.
- SANYO Electric Co., Ltd. strives to supply high-quality high-reliability products. However, any and all semiconductor products fail with some probability. It is possible that these probabilistic failures could give rise to accidents or events that could endanger human lives, that could give rise to smoke or fire, or that could cause damage to other property. When designing equipment, adopt safety measures so that these kinds of accidents or events cannot occur. Such measures include but are not limited to protective circuits and error prevention circuits for safe design, redundant design, and structural design.
- In the event that any or all SANYO products (including technical data, services) described or contained herein are controlled under any of applicable local export control laws and regulations, such products must not be exported without obtaining the export license from the authorities concerned in accordance with the above law.
- No part of this publication may be reproduced or transmitted in any form or by any means, electronic or mechanical, including photocopying and recording, or any information storage or retrieval system, or otherwise, without the prior written permission of SANYO Electric Co., Ltd.
- Any and all information described or contained herein are subject to change without notice due to product/technology improvement, etc. When designing equipment, refer to the "Delivery Specification" for the SANYO product that you intend to use.
- Information (including circuit diagrams and circuit parameters) herein is for example only; it is not guaranteed for volume production. SANYO believes information herein is accurate and reliable, but no guarantees are made or implied regarding its use or any infringements of intellectual property rights or other rights of third parties.