

SLUS349A – DECEMBER 1994 – REVISED APRIL 2003

9-LINE 3 TO 5 VOLT LOW CAPACITANCE SCSI ACTIVE TERMINATOR

FEATURES

- Complies with SCSI, SCSI-2 and SPI-2 Single Ended Standards
- 2.7-V to 5.25-V Operation
- 1.8-pF Channel Capacitance during Disconnect
- 0.5- μ A Supply Current in Disconnect Mode
- 110- Ω /2.5-k Ω Programmable Termination
- Completely Meets SCSI Hot Plugging
- -400-mA Sourcing Current for Termination
- +400-mA Sinking Current for Active Negation Drivers
- Trimmed Termination Current to 4%
- Trimmed Impedance to 7%
- Current Limit and Thermal Shutdown Protection

DESCRIPTION

The UCC5614 provides 9 lines of active termination for a small computer system's interface (SCSI) parallel bus. The SCSI standard recommends active termination at both ends of the cable segment.

The UCC5614 is ideal for high performance 3.3-V SCSI systems. The key features contributing to such low operating voltage are the 0.1-V dropout regulator and the 2.7-V reference. During disconnect the supply current is typically only 0.5 μ A, which makes the device attractive for battery powered systems.

The UCC5614 is designed with an ultra low channel capacitance of 1.8 pF, which eliminates effects on signal integrity from disconnected terminators at interim points on the bus.

BLOCK DIAGRAM

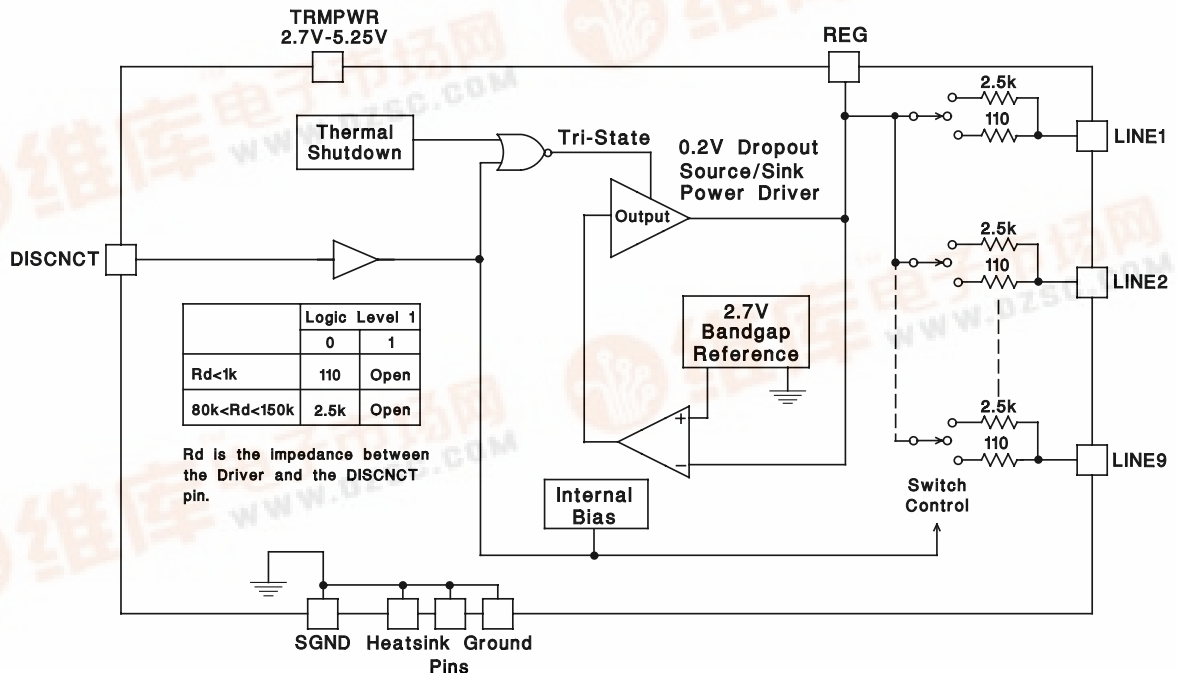

UCC5614

SLUS349A – DECEMBER 1994 – REVISED APRIL 2003

DESCRIPTION (CONTINUED)

The UCC5614 can be programmed for either a 110- Ω or 2.5-k Ω termination. The 110- Ω termination is used for standard SCSI bus lengths and the 2.5-k Ω termination is typically used in short bus applications. When driving the TTL compatible DISCNCT pin directly, the 110- Ω termination is connected when the DISCNCT pin is driven low, and disconnected when driven high. When the DISCNCT pin is driven through an impedance between 80 k Ω and 150 k Ω , the terminator is in short bus mode. The 2.5-k Ω termination is connected when the DISCNCT pin is driven low and disconnected when driven high.

The power amplifier output stage allows the UCC5614 to source full termination current and sink active negation current when all termination lines are actively negated.

The UCC5614 is pin for pin compatible with Unitrode's other 9-line SCSI terminators, allowing lower capacitance and lower voltage upgrades to existing systems. The UCC5614, as with all Unitrode terminators, is completely hot pluggable and appears as high impedance at the terminating channels with VTRMPWR = 0 V or open.

Internal circuit trimming is utilized, first to trim the 110- Ω termination impedance to a 7% tolerance, and then most importantly, to trim the output current to a 4% tolerance, as close to the max SCSI specification as possible, which maximizes noise margin in fast SCSI operation.

Other features include thermal shutdown and current limit.

This device is offered in low thermal resistance versions of the industry standard 16-pin narrow body SOIC, 16-pin N and 24-pin TSSOP.

ORDERING INFORMATION

T _A	PACKAGED DEVICE		
	SOIC-16 (DP) [†]	DIL-16 (N)	TSSOP-24 (PWP) [‡]
0°C to 70°C	UCC5614DP	UCC5614N	UCC5614PWP

[†] The DP package is available taped and reeled in quantities of 2,500. Add TR suffix to device type (e.g. UCC5614DPTR) to order quantities of 2,500 devices per reel.

[‡] The PWP package is available taped and reeled in quantities of 2,000. Add TR suffix to device type (e.g. UCC5614PWPTR) to order quantities of 2,000 devices per reel.

CONNECTION DIAGRAMS

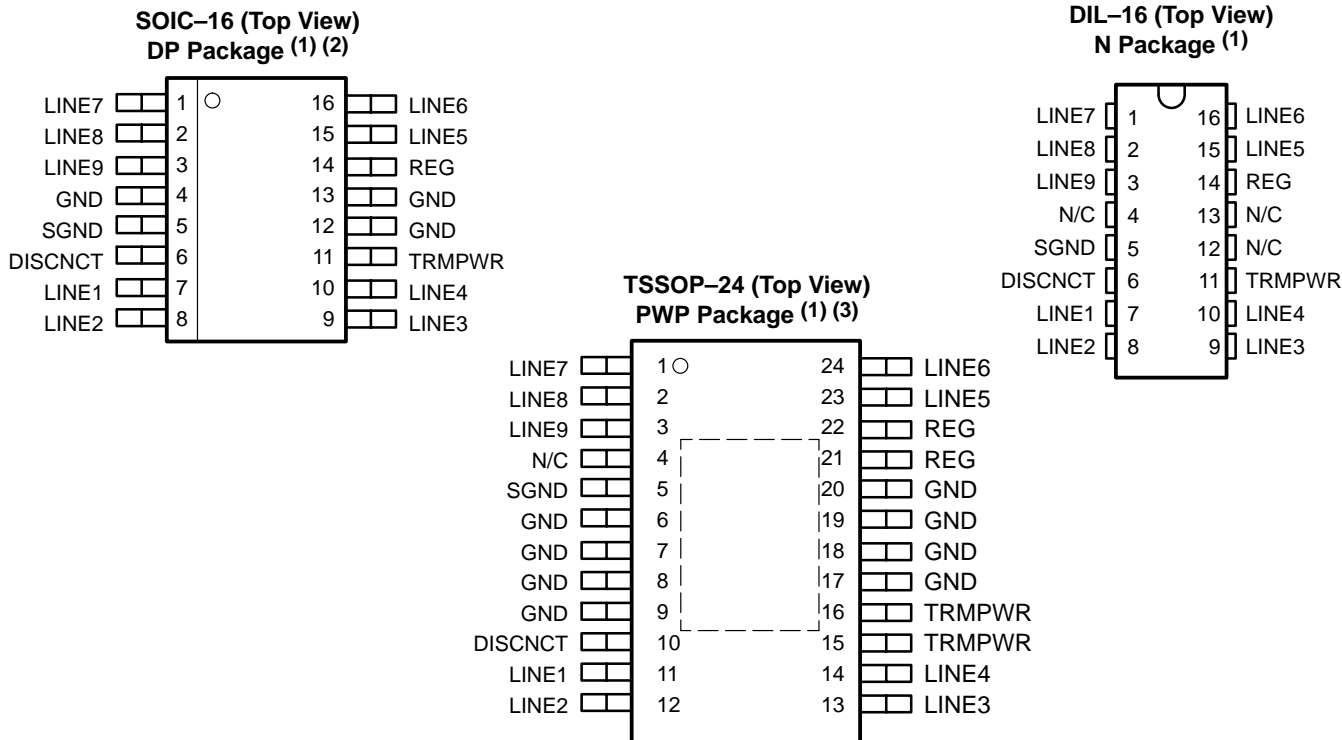

- NOTES: (1). Drawings are not to scale.
 (2). DP package pin 5 serves as ground and pins 4,12 and 13 serve as heatsink ground.
 (3). PWP package pin 5 serves as ground and pins 6,7,8,9,17,18,19 and 20 serve as heatsink ground.

ABSOLUTE MAXIMUM RATINGS

over operating free-air temperature range unless otherwise noted†‡

	UCC5629	UNIT
TRMPWR voltage	6	V
Input voltage	0 to 7	
Regulator output current	2	W
Storage temperature, T _{stg}	-65 to 150	°C
Operating junction temperature, T _J	-55 to 150	
Lead temperature (soldering, 10 sec.)	300	

† Stresses beyond those listed under “absolute maximum ratings” may cause permanent damage to the device. These are stress ratings only, and functional operation of the device at these or any other conditions beyond those indicated under “recommended operating conditions” is not implied. Exposure to absolute-maximum-rated conditions for extended periods may affect device reliability. All voltages are with respect to GND. Currents are positive into and negative out of, the specified terminal.

‡ Currents are positive into, negative out of the specified terminal. Consult Packaging Section of Databook for thermal limitations and considerations of packages. All voltages are referenced to GND.

RECOMMENDED OPERATING CONDITIONS

	MIN	NOM	MAX	UNIT
TRMPWR voltage	2.7		5.25	V
Temperature ranges	0		70	°C
Signal line voltage	0		5	V
DISCNCT input voltage	0	TRMPWR		

UCC5614

SLUS349A – DECEMBER 1994 – REVISED APRIL 2003

ELECTRICAL CHARACTERISTICS

$T_A = 0^\circ\text{C}$ to 70°C , $\text{TRMPWR} = 3.3\text{ V}$, $\text{DISCNCT} = 0\text{ V}$, $R_{\text{DISCNCT}} = 0\ \Omega$, $T_A = T_J$, (unless otherwise noted)

PARAMETER	TEST CONDITIONS	MIN	TYP	MAX	UNITS
Supply Current Section					
Tempwr supply current	All termination lines = Open		1	2	mA
	All termination lines = 0.2 V		210	218	
Power down mode	DISCNCT = Trmpwr		0.5	5	μA
Output Section (110 Ω – Terminator Lines)					
Terminator impedance		102.3	110	117.7	Ohms
Output high voltage	(Note 1)	2.5	2.7	3.0	V
Max output current	VLINE = 0.2 V $T_J = 25^\circ\text{C}$	-22.1	-23	-24	mA
	VLINE = 0.2 V	-21	-23	-24	
	VLINE = 0.2 V, TRMPWR = 3 V, $T_J = 25^\circ\text{C}$ (Note 1)	-20.2	-23	-24	
	VLINE = 0.2 V, TRMPWR = 3 V (Note 1)	-19	-23	-24	
	VLINE = 0.5 V			-22.4	
Output leakage	DISCNCT = 2.4 V, TRMPWR = 0 V to 5.25 V		10	400	nA
Output capacitance	DISCNCT = 2.4 V (Note 2) (DP Package)		1.8	2.5	pF
Output Section (2.5 kΩ – Terminator Lines) ($R_{\text{DISCNCT}} = 80\text{ k}\Omega$)					
Terminator impedance		2	2.5	3	k Ω
Output high voltage	TRMPWR = 3 V (Note 1)	2.5	2.7	3.0	V
Max output current	VLINE = 0.2 V	-0.7	-1	-1.4	mA
	VLINE = 0.2 V, TRMPWR = 3 V (Note 1)	-0.6	-1	-1.5	
Output leakage	DISCNCT = 2.4 V, TRMPWR = 0 to 5.25 V		10	400	nA
Output capacitance	DISCNCT = 2.4 V (Note 2) (DP Package)		1.8	2.5	pF
Regulator Section					
Regulator output voltage	5.25 V > TRMPWR > 3 V	2.5	2.7	3.0	V
Drop out voltage	All Termination Lines = 0.2 V		0.1	0.2	
Short circuit current	VREG = 0 V	-200	-400	-800	mA
Sinking current capability	VREG = 3 V	200	400	800	
Thermal shutdown	(Note 2)		170		$^\circ\text{C}$
Thermal shutdown hysteresis	(Note 2)		10		
Disconnect Section					
Disconnect threshold	$R_{\text{DISCNCT}} = 0$ & 80 k Ω	0.8	1.5	2.0	V
Input current	DISCNCT = 0 V		30	50	mA

NOTES: 1. Measuring each termination line while other eight are low (0.2 V).
2. Ensured by design. Not production tested.

Terminal Functions

TERMINAL NAME	NO.	I/O	DESCRIPTION
DISCNCT	7	I	Taking this pin high causes the 9 channels to become high impedance and the chip to go into low power mode. In short laptop buses an 80-k Ω to 150-k Ω resistor to ground terminates the bus at 2.5 k Ω . Less than 110 Ω to ground enables the terminator.
GND	9		Ground reference for the device
LINE1 TO LINE9	4	I	110- Ω termination channels
REG	9	o	Output of the internal 2.7-V regulator
TRMPWR	4	I	Power for the device

APPLICATION INFORMATION

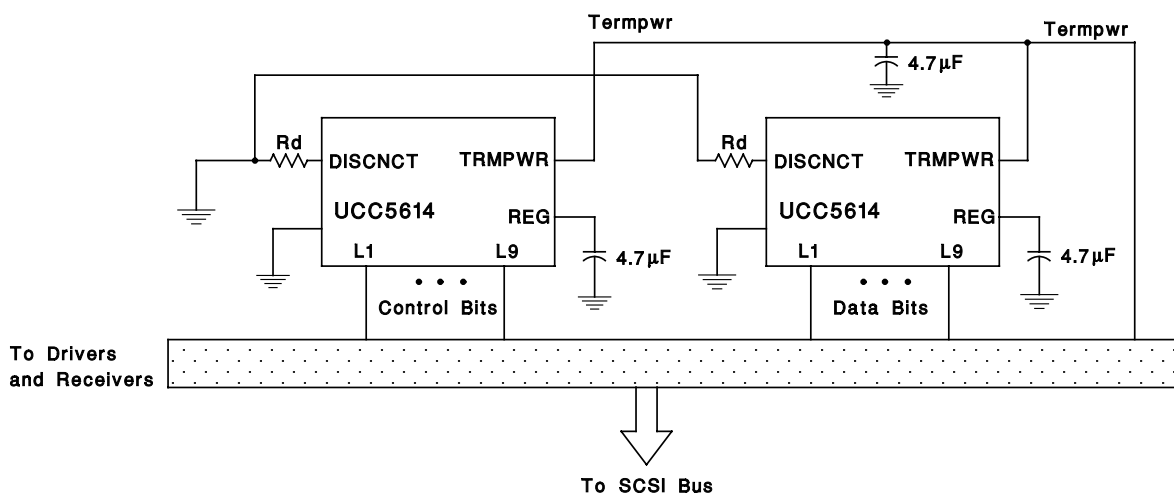

Figure 1. Typical SCSI Bus Configuration Utilizing two UCC5614 Devices

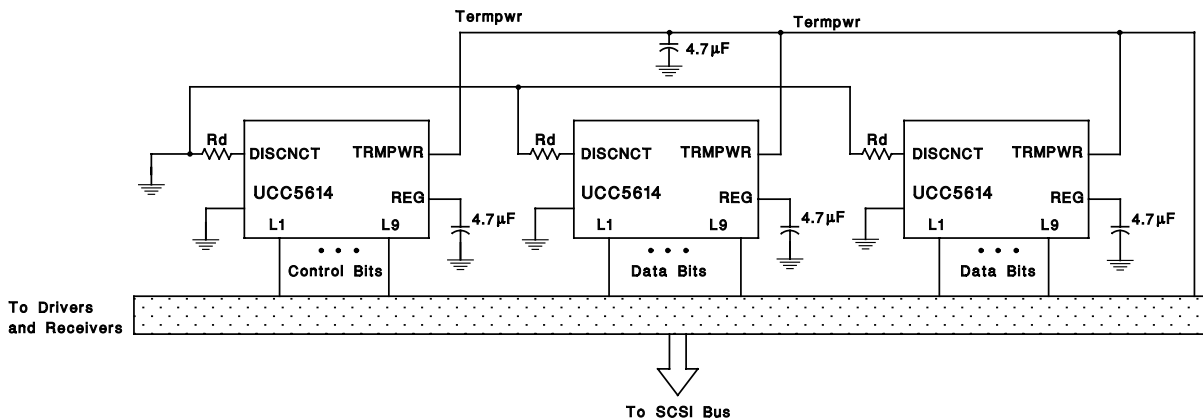

Figure 2. Typical Wide SCSI Bus Configuration Utilizing three UCC5614 Devices

UCC5614

SLUS349A – DECEMBER 1994 – REVISED APRIL 2003

MECHANICAL DATA

PWP (R-PDSO-G**)

PowerPAD™ PLASTIC SMALL-OUTLINE

20 PINS SHOWN

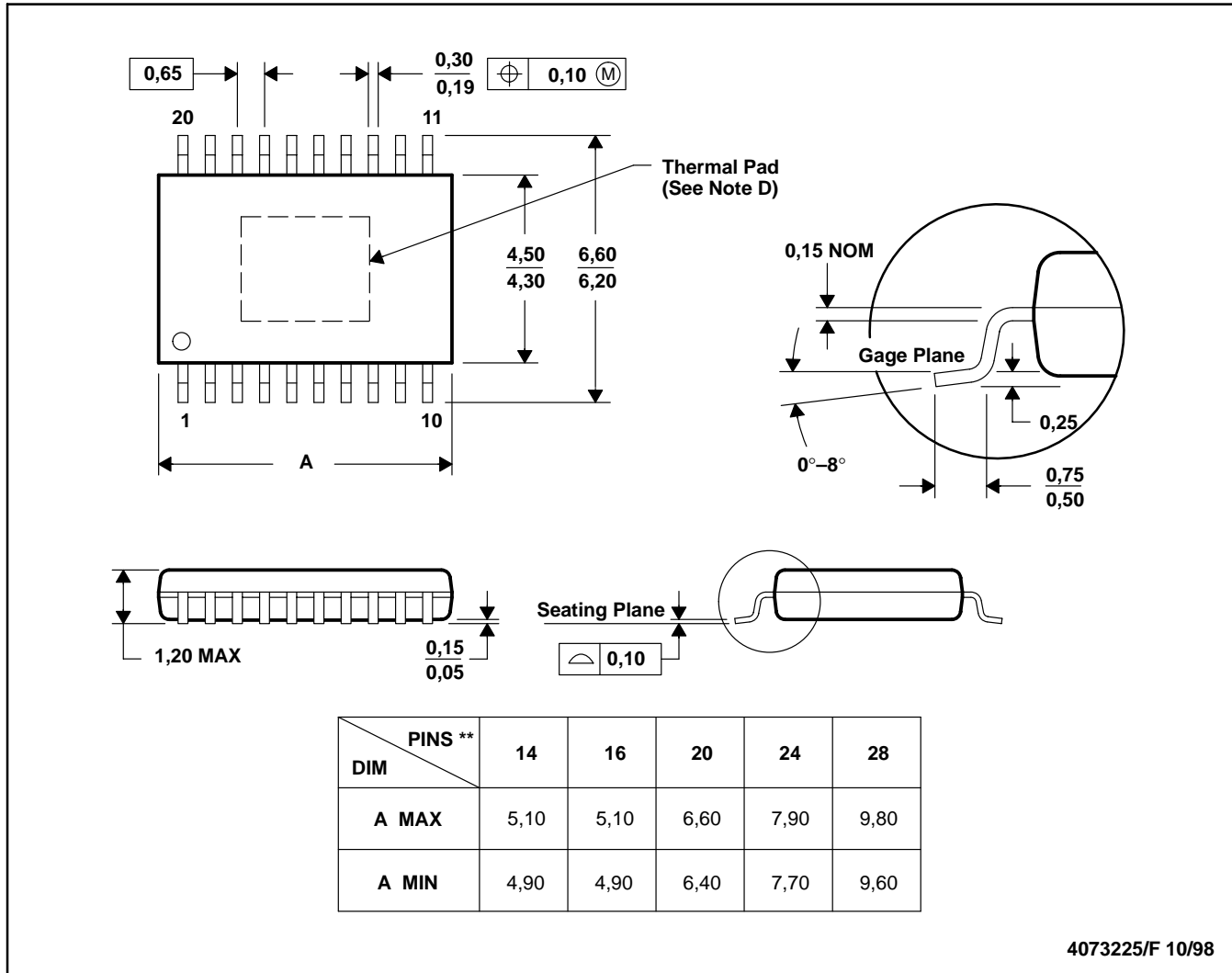

4073225/F 10/98

- NOTES: A. All linear dimensions are in millimeters.
 B. This drawing is subject to change without notice.
 C. Body dimensions do not include mold flash or protrusions.
 D. The package thermal performance may be enhanced by bonding the thermal pad to an external thermal plane. This pad is electrically and thermally connected to the backside of the die and possibly selected leads.
 E. Falls within JEDEC MO-153

IMPORTANT NOTICE

Texas Instruments Incorporated and its subsidiaries (TI) reserve the right to make corrections, modifications, enhancements, improvements, and other changes to its products and services at any time and to discontinue any product or service without notice. Customers should obtain the latest relevant information before placing orders and should verify that such information is current and complete. All products are sold subject to TI's terms and conditions of sale supplied at the time of order acknowledgment.

TI warrants performance of its hardware products to the specifications applicable at the time of sale in accordance with TI's standard warranty. Testing and other quality control techniques are used to the extent TI deems necessary to support this warranty. Except where mandated by government requirements, testing of all parameters of each product is not necessarily performed.

TI assumes no liability for applications assistance or customer product design. Customers are responsible for their products and applications using TI components. To minimize the risks associated with customer products and applications, customers should provide adequate design and operating safeguards.

TI does not warrant or represent that any license, either express or implied, is granted under any TI patent right, copyright, mask work right, or other TI intellectual property right relating to any combination, machine, or process in which TI products or services are used. Information published by TI regarding third-party products or services does not constitute a license from TI to use such products or services or a warranty or endorsement thereof. Use of such information may require a license from a third party under the patents or other intellectual property of the third party, or a license from TI under the patents or other intellectual property of TI.

Reproduction of information in TI data books or data sheets is permissible only if reproduction is without alteration and is accompanied by all associated warranties, conditions, limitations, and notices. Reproduction of this information with alteration is an unfair and deceptive business practice. TI is not responsible or liable for such altered documentation.

Resale of TI products or services with statements different from or beyond the parameters stated by TI for that product or service voids all express and any implied warranties for the associated TI product or service and is an unfair and deceptive business practice. TI is not responsible or liable for any such statements.

Mailing Address:

Texas Instruments
Post Office Box 655303
Dallas, Texas 75265