



96% EFFICIENT SYNCHRONOUS BOOST CONVERTER WITH 1.5-A SWITCH

FEATURES

- **96% Efficient Synchronous Boost Converter**
– 200-mA Output Current From 0.9-V Input
– 500-mA Output Current From 1.8-V Input
- **Output Voltage Remains Regulated When Input Voltage Exceeds Nominal Output Voltage**
- **Device Quiescent Current: 25- μ A (Typ)**
- **Input Voltage Range: 0.9-V to 6.5-V**
- **Fixed and Adjustable Output Voltage Options Up to 5.5-V**
- **Power Save Mode for Improved Efficiency at Low Output Power**
- **Low Battery Comparator**
- **Low EMI-Converter (Integrated Antiringing Switch)**
- **Load Disconnect During Shutdown**
- **Over-Temperature Protection**
- **Small 3 mm x 3 mm QFN-10 Package**

APPLICATIONS

- **All One-Cell, Two-Cell and Three-Cell Alkaline, NiCd or NiMH or Single-Cell Li Battery Powered Products**
- **Portable Audio Players**
- **PDA's**
- **Cellular Phones**
- **Personal Medical Products**
- **Camera White LED Flash Light**

DESCRIPTION

The TPS6102x devices provide a power supply solution for products powered by either a one-cell, two-cell, or three-cell alkaline, NiCd or NiMH, or one-cell Li-Ion or Li-polymer battery. Output currents can go as high as 200 mA while using a single-cell alkaline, and discharge it down to 0.9 V. It can also be used for generating 5 V at 500 mA from a 3.3-V rail or a Li-Ion battery. The boost converter is based on a fixed frequency, pulse-width-modulation (PWM) controller using a synchronous rectifier to obtain maximum efficiency. At low load currents the converter enters the Power Save mode to maintain a high efficiency over a wide load current range. The Power Save mode can be disabled, forcing the converter to operate at a fixed switching frequency. The maximum peak current in the boost switch is limited to a value of 1500 mA.

The TPS6102x devices keep the output voltage regulated even when the input voltage exceeds the nominal output voltage. The output voltage can be programmed by an external resistor divider, or is fixed internally on the chip. The converter can be disabled to minimize battery drain. During shutdown, the load is completely disconnected from the battery. A low-EMI mode is implemented to reduce ringing and, in effect, lower radiated electromagnetic energy when the converter enters the discontinuous conduction mode. The device is packaged in a 10-pin QFN PowerPAD™ package measuring 3 mm x 3 mm (DRC).

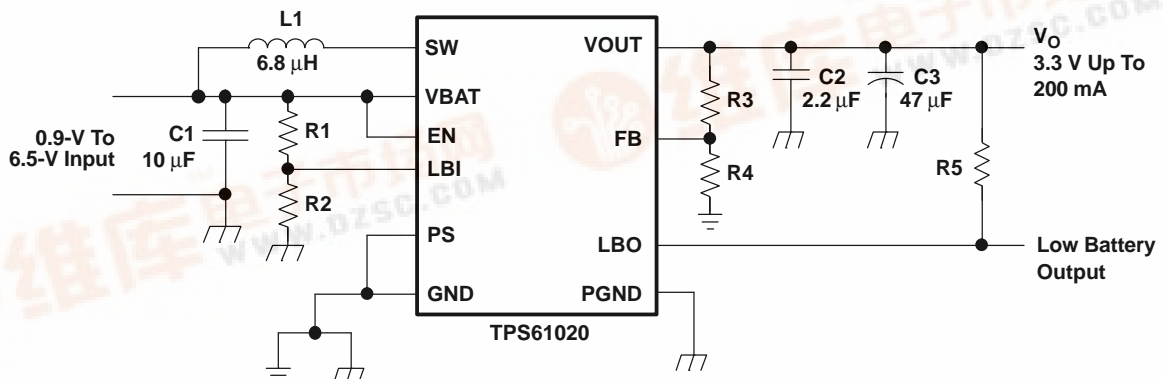

TPS61020, TPS61024 TPS61025, TPS61027

SLVS451 – SEPTEMBER 2003



These devices have limited built-in ESD protection. The leads should be shorted together or the device placed in conductive foam during storage or handling to prevent electrostatic damage to the MOS gates.

AVAILABLE OUTPUT VOLTAGE OPTIONS (1)

T_A	OUTPUT VOLTAGE DC/DC	PACKAGE MARKING	PACKAGE	PART NUMBER (2)
40°C to 85°C	Adjustable	BDR	10-Pin QFN	TPS61020DRC
	3.0 V	BDS		TPS61024DRC
	3.3 V	BDT		TPS61025DRC
	5 V	BDU		TPS61027DRC

- (1) Contact the factory to check availability of other fixed output voltage versions.
- (2) The DRC package is available taped and reeled. Add R suffix to device type (e.g., TPS61020DRCR) to order quantities of 3000 devices per reel.

ABSOLUTE MAXIMUM RATINGS

over operating free-air temperature range (unless otherwise noted) (1)

	TPS6102X
Input voltage range on SW, VOUT, LBO, VBAT, PS, EN, FB, LBI	-0.3 V to 7 V
Operating virtual junction temperature range, T_J	-40°C to 150°C
Storage temperature range T_{stg}	-65°C to 150°C

- (1) Stresses beyond those listed under "absolute maximum ratings" may cause permanent damage to the device. These are stress ratings only, and functional operation of the device at these or any other conditions beyond those indicated under "recommended operating conditions" is not implied. Exposure to absolute-maximum-rated conditions for extended periods may affect device reliability.

DISSIPATION RATINGS TABLE

PACKAGE	THERMAL RESISTANCE Θ_{JA}	POWER RATING $T_A \leq 25^\circ\text{C}$	DERATING FACTOR ABOVE $T_A = 25^\circ\text{C}$
DRC	48.7 °C/W	2054 mW	21 mW/°C

RECOMMENDED OPERATING CONDITIONS

	MIN	NOM	MAX	UNIT
Supply voltage at VBAT, V_I	0.9		6.5	V
Operating free air temperature range, T_A	-40		85	°C
Operating virtual junction temperature range, T_J	-40		125	°C

ELECTRICAL CHARACTERISTICS

over recommended free-air temperature range and over recommended input voltage range (typical at an ambient temperature range of 25°C) (unless otherwise noted)

DC/DC STAGE						
PARAMETER		TEST CONDITIONS	MIN	TYP	MAX	UNIT
V _I	Minimum input voltage range for start-up	R _L = 120 Ω		0.9	1.2	V
	Input voltage range, after start-up		0.9		6.5	
V _O	TPS61020 output voltage range		1.8		5.5	V
V _{FB}	TPS61020 feedback voltage		490	500	510	mV
f	Oscillator frequency		480	600	720	kHz
I _{SW}	Switch current limit	V _{OUT} = 3.3 V	1200	1500	1800	mA
	Start-up current limit			0.4 × I _{SW}		mA
	SWN switch on resistance	V _{OUT} = 3.3 V		260		mΩ
	SWP switch on resistance	V _{OUT} = 3.3 V		290		mΩ
	Total accuracy (including line and load regulation)				3%	
	Line regulation				0.6%	
	Load regulation				0.6%	
Quiescent current	V _{BAT}	I _O = 0 mA, V _{EN} = V _{BAT} = 1.2 V, V _{OUT} = 3.3 V, T _A = 25°C		1	3	μA
	V _{OUT}			25	45	μA
Shutdown current		V _{EN} = 0 V, V _{BAT} = 1.2 V, T _A = 25°C		0.1	1	μA

CONTROL STAGE						
PARAMETER		TEST CONDITIONS	MIN	TYP	MAX	UNIT
V _{UVLO}	Under voltage lockout threshold	V _{LBI} voltage decreasing		0.8		V
V _{IL}	LBI voltage threshold	V _{LBI} voltage decreasing	490	500	510	mV
	LBI input hysteresis			10		mV
	LBI input current	EN = V _{BAT} or GND		0.01	0.1	μA
V _{OL}	LBO output low voltage	V _O = 3.3 V, I _{OI} = 100 μA		0.04	0.4	V
	LBO output low current			100		μA
V _{lkg}	LBO output leakage current	V _{LBO} = 7 V		0.01	0.1	μA
V _{IL}	EN, PS input low voltage				0.2 × V _{BAT}	V
V _{IH}	EN, PS input high voltage		0.8 × V _{BAT}			V
	EN, PS input current	Clamped on GND or V _{BAT}		0.01	0.1	μA
	Overtemperature protection			140		°C
	Overtemperature hysteresis			20		°C

**TPS61020, TPS61024
TPS61025, TPS61027**

SLVS451 – SEPTEMBER 2003

PIN ASSIGNMENTS

**DRC PACKAGE
(TOP VIEW)**

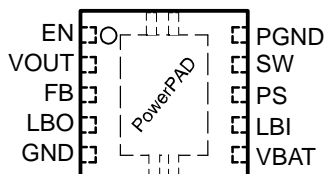

Terminal Functions

TERMINAL		I/O	DESCRIPTION
NAME	NO.		
EN	1	I	Enable input. (1/VBAT enabled, 0/GND disabled)
FB	3	I	Voltage feedback of adjustable versions
GND	5		Control / logic ground
LBI	7	I	Low battery comparator input (comparator enabled with EN)
LBO	4	O	Low battery comparator output (open drain)
PS	8	I	Enable/disable power save mode (1 / VBAT disabled, 0/ GND enabled)
SW	9	I	Boost and rectifying switch input
PGND	10		Power ground
VBAT	6	I	Supply voltage
VOUT	2	O	Boost converter output
PowerPAD™			Must be soldered to achieve appropriate power dissipation. Should be connected to PGND.

FUNCTIONAL BLOCK DIAGRAM (TPS61020)

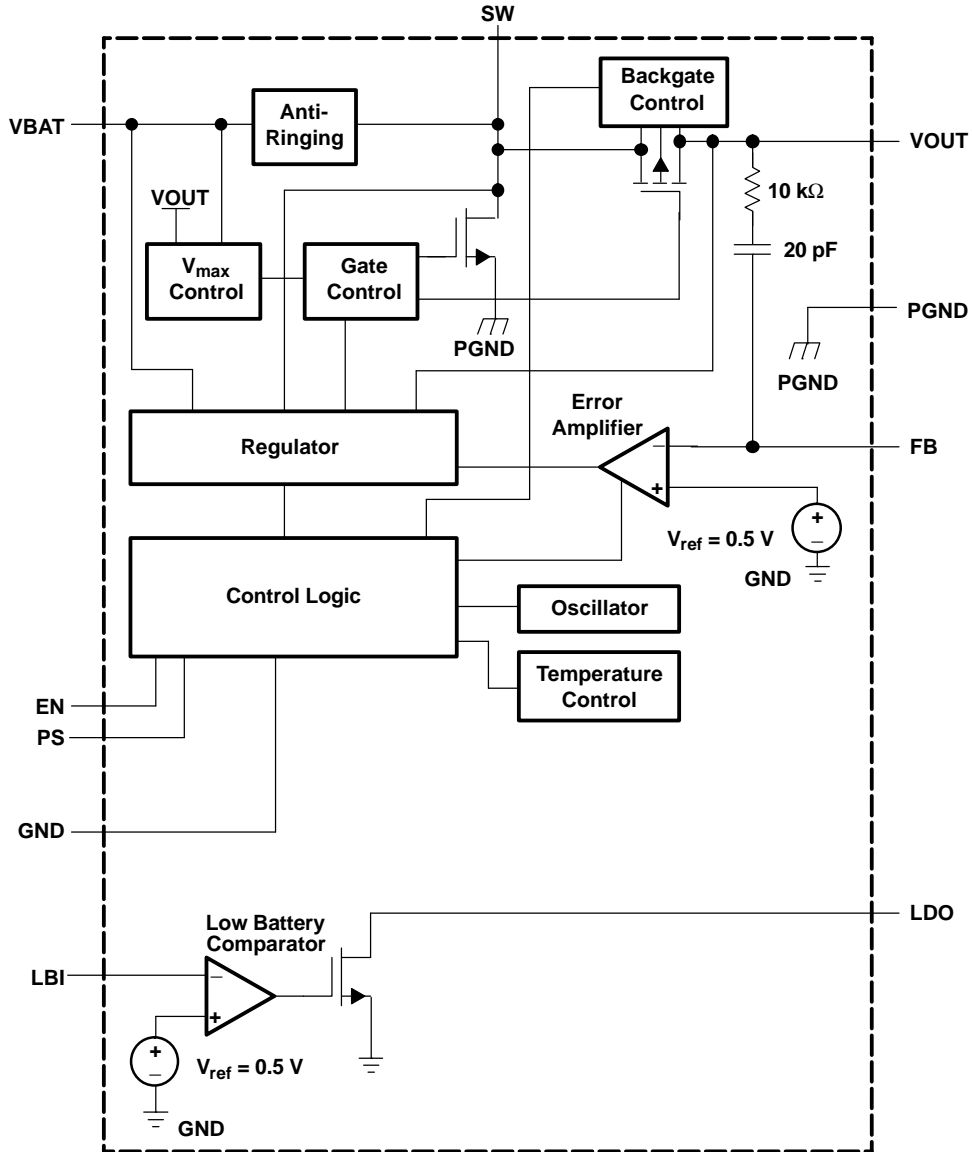

PARAMETER MEASUREMENT INFORMATION

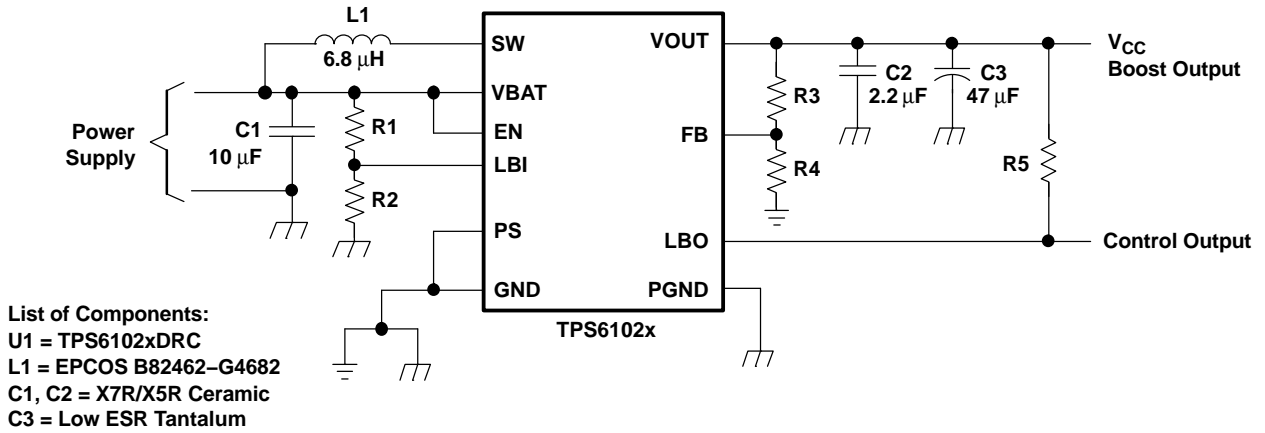

TYPICAL CHARACTERISTICS

Table of Graphs

		FIGURE
Maximum output current	vs Input voltage	1
Efficiency	vs Output current (TPS61020)	2
	vs Output current (TPS61025)	3
	vs Output current (TPS61027)	4
	vs Input voltage (TPS61025)	5
	vs Input voltage (TPS61027)	6
Output voltage	vs Output current (TPS61025)	7
	vs Output current (TPS61027)	8
No load supply current into VBAT	vs Input voltage	9
No load supply current into VOUT	vs Input voltage	10
Waveforms	Output voltage in continuous mode (TPS61025)	11
	Output voltage in continuous mode (TPS61027)	12
	Output voltage in power save mode (TPS61025)	13
	Output voltage in power save mode (TPS61027)	14
	Load transient response (TPS61025)	15
	Load transient response (TPS61027)	16
	Line transient response (TPS61025)	17
	Line transient response (TPS61027)	18
	Start-up after enable (TPS61025)	19
	Start-up after enable (TPS61027)	20

TYPICAL CHARACTERISTICS

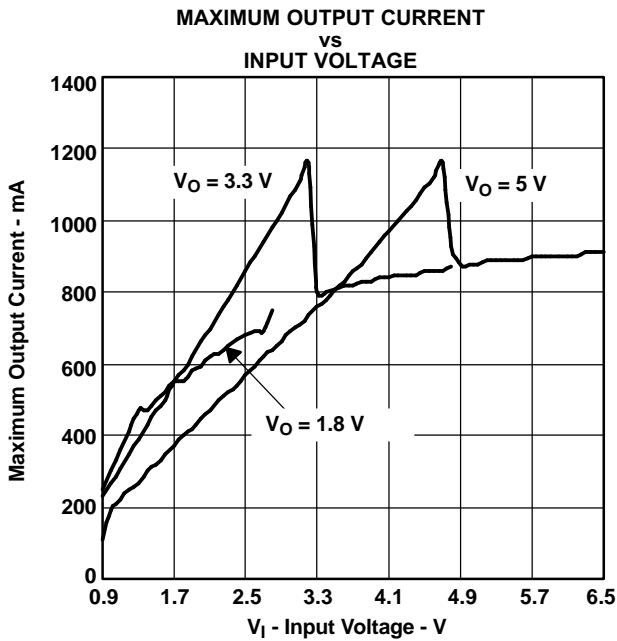

Figure 1.

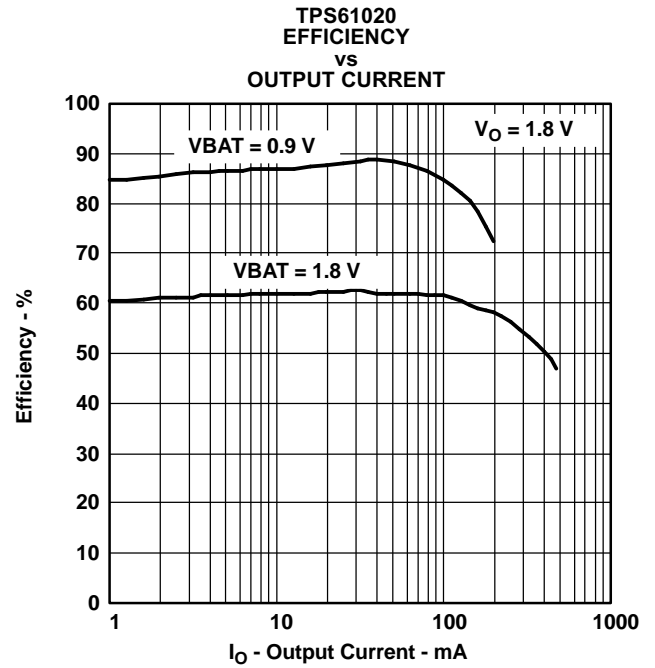

Figure 2.

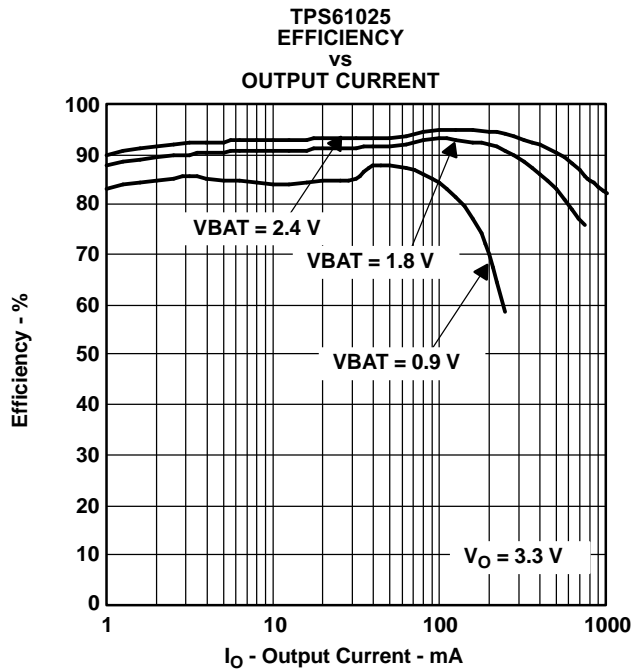

Figure 3.

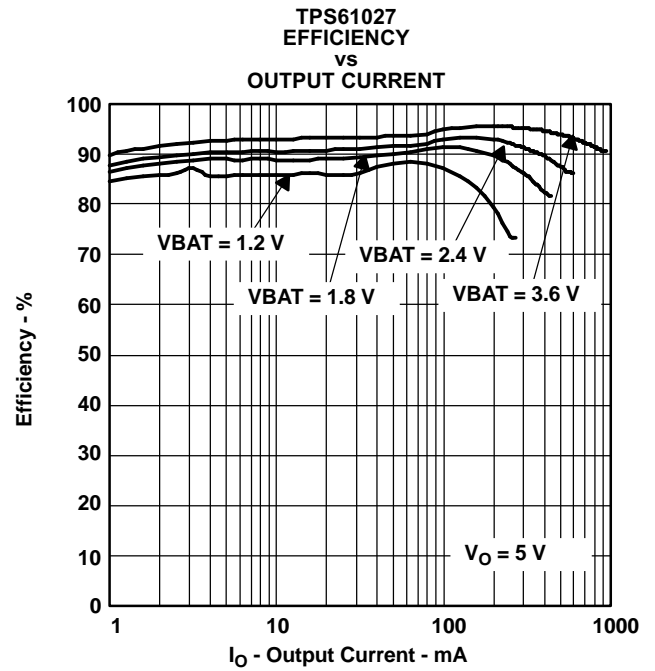

Figure 4.

TYPICAL CHARACTERISTICS (continued)

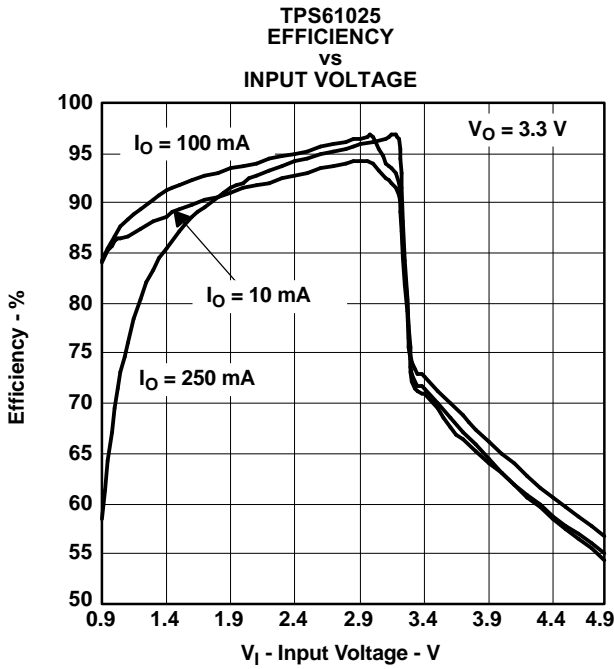

Figure 5.

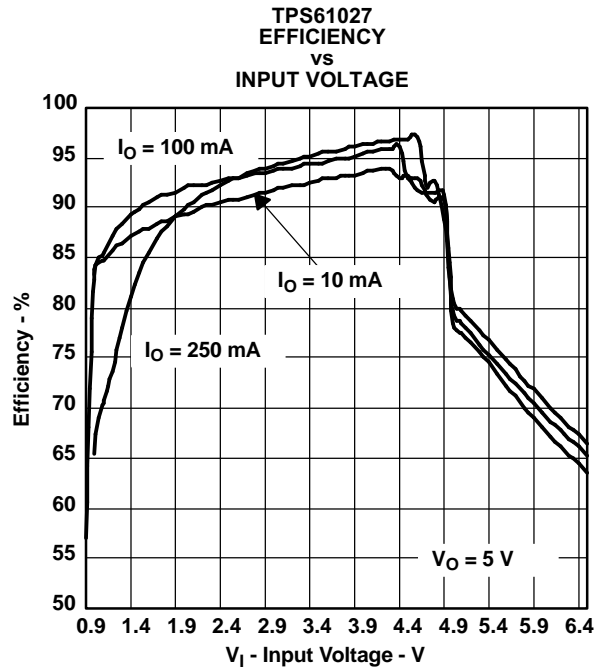

Figure 6.

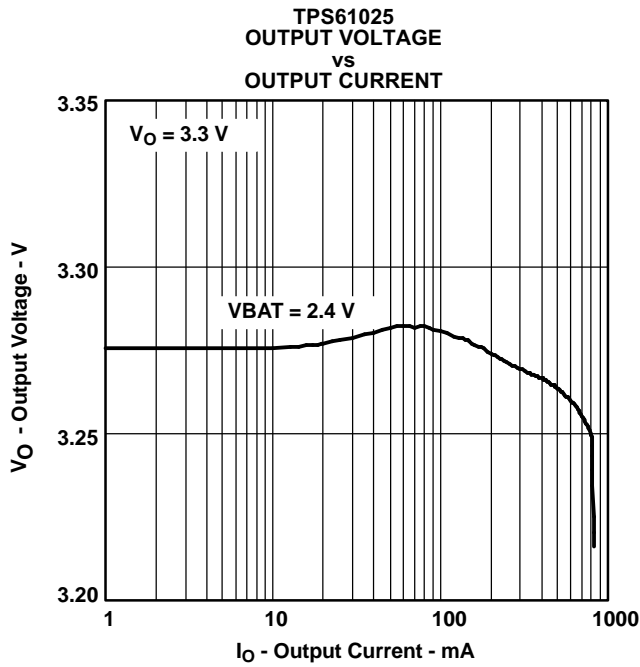

Figure 7.

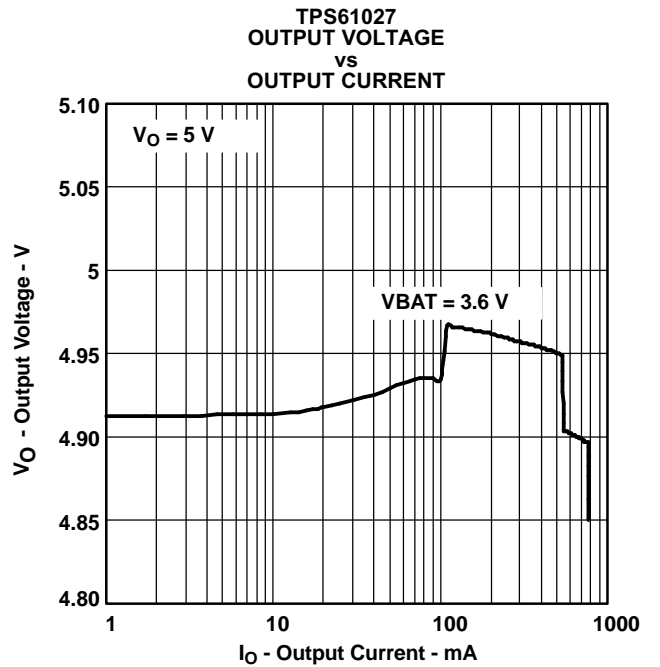
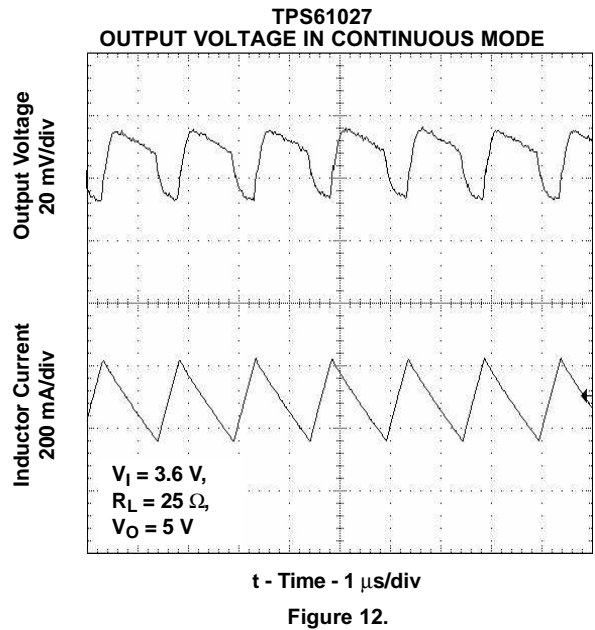
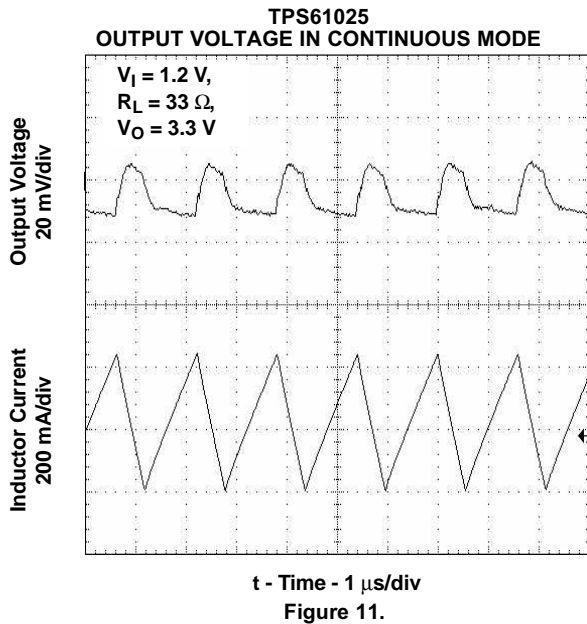
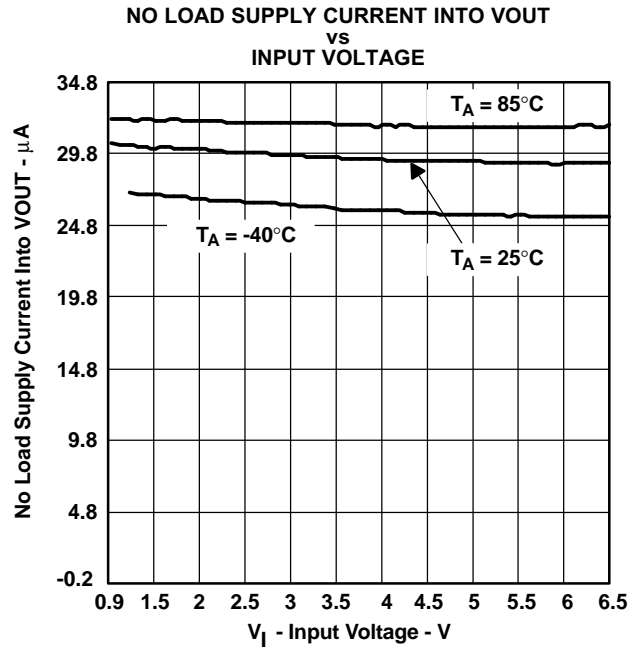
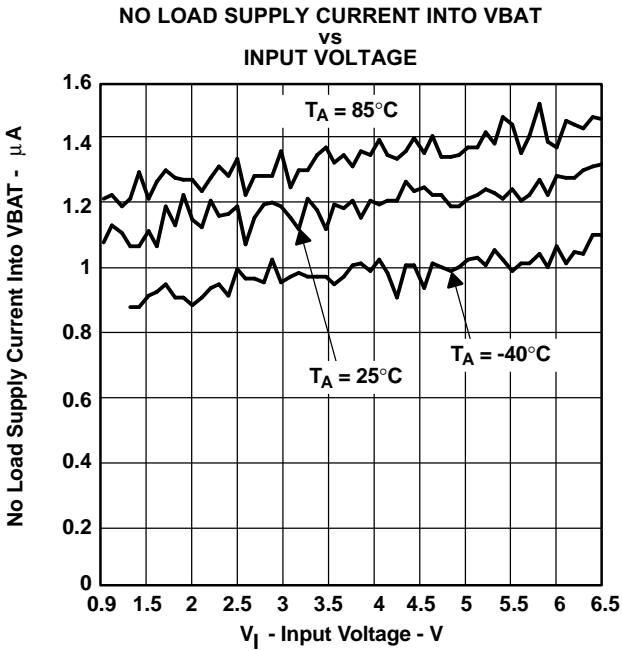

Figure 8.

TYPICAL CHARACTERISTICS (continued)



TYPICAL CHARACTERISTICS (continued)

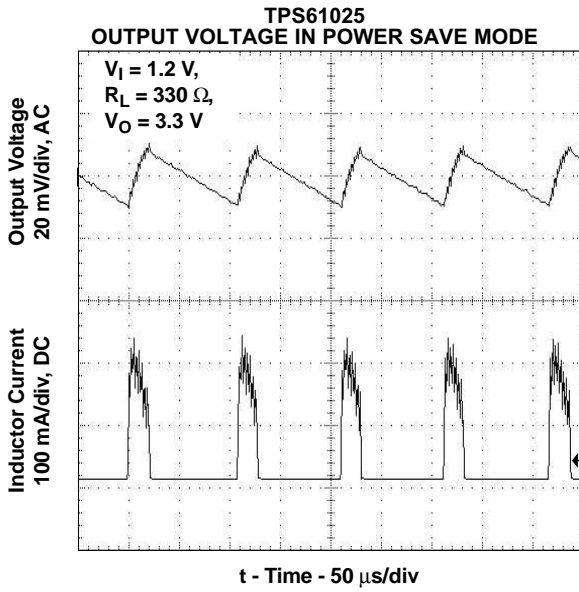

Figure 13.

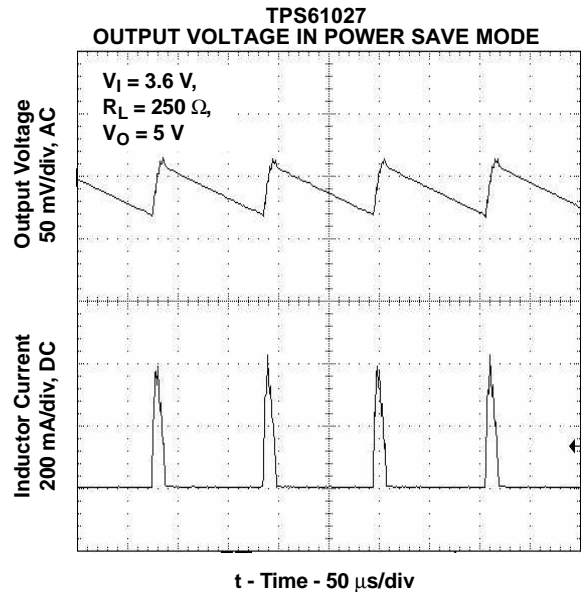

Figure 14.

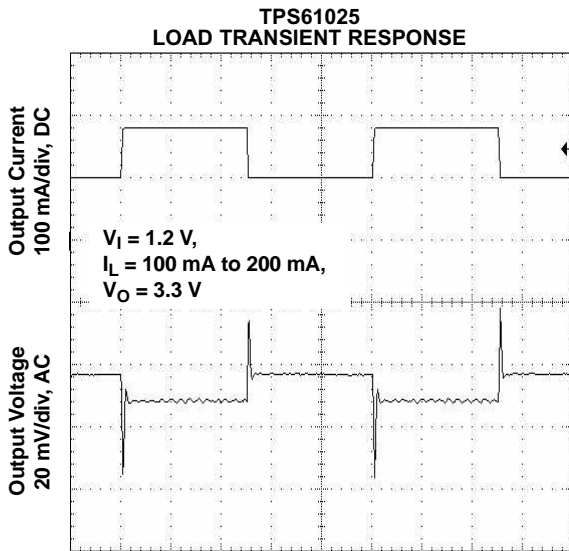

Figure 15.

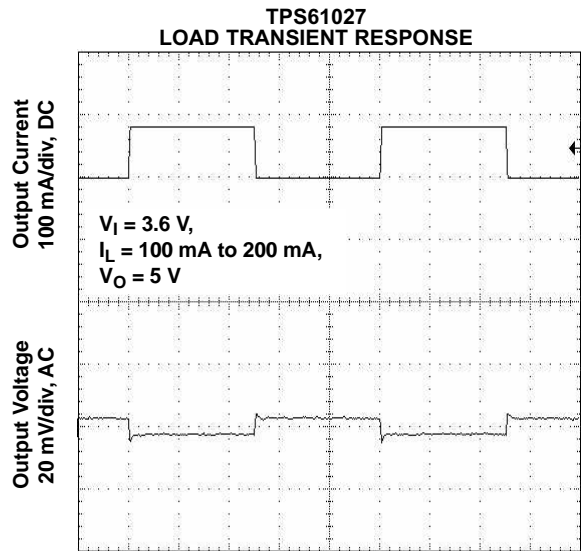
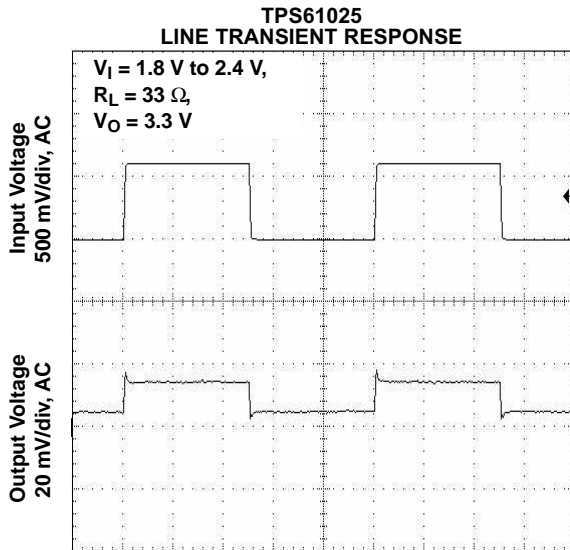
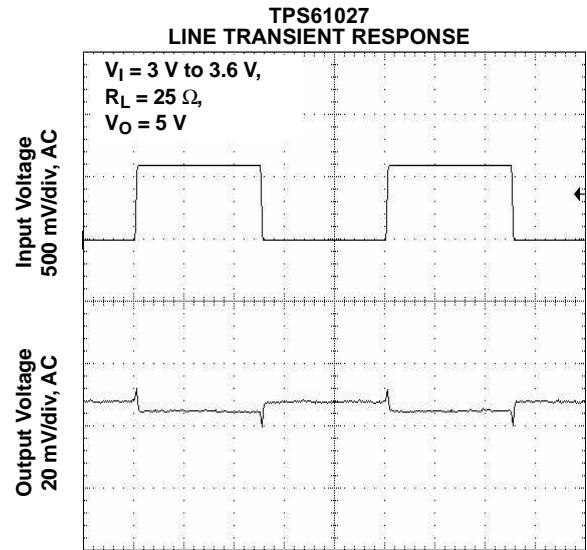

Figure 16.

TYPICAL CHARACTERISTICS (continued)



t - Time - 2 ms/div
Figure 17.



t - Time - 2 ms/div
Figure 18.

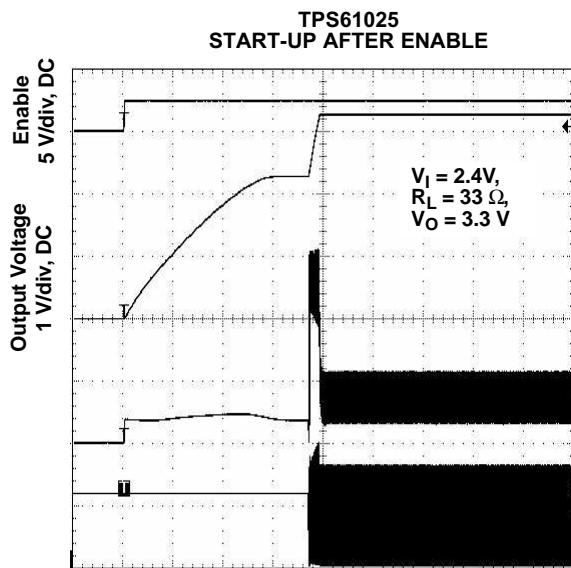

t - Time - 1 ms/div
Figure 19.

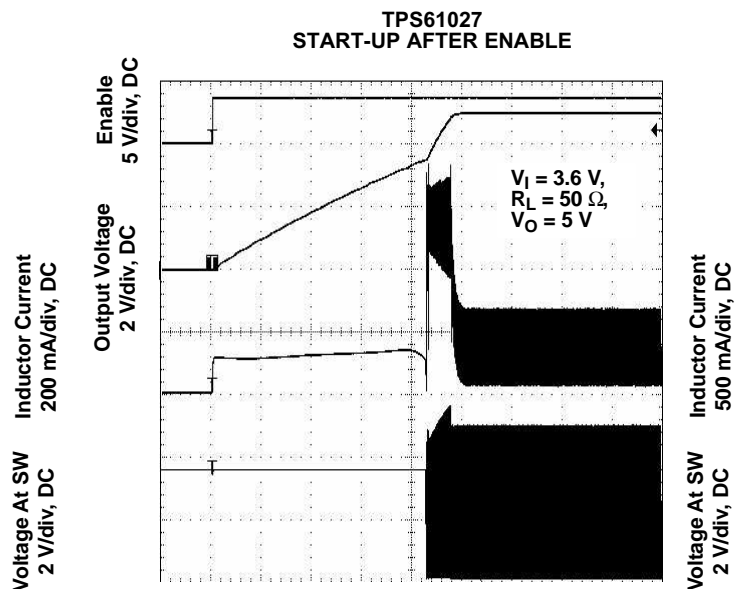

t - Time - 500 μ s/div
Figure 20.

DETAILED DESCRIPTION

CONTROLLER CIRCUIT

The controller circuit of the device is based on a fixed frequency multiple feedforward controller topology. Input voltage, output voltage, and voltage drop on the NMOS switch are monitored and forwarded to the regulator. So changes in the operating conditions of the converter directly affect the duty cycle and must not take the indirect and slow way through the control loop and the error amplifier. The control loop, determined by the error amplifier, only has to handle small signal errors. The input for it is the feedback voltage on the FB pin or, at fixed output voltage versions, the voltage on the internal resistor divider. It is compared with the internal reference voltage to generate an accurate and stable output voltage.

The peak current of the NMOS switch is also sensed to limit the maximum current flowing through the switch and the inductor. The typical peak current limit is set to 1500 mA. An internal temperature sensor prevents the device from getting overheated in case of excessive power dissipation.

Synchronous Rectifier

The device integrates an N-channel and a P-channel MOSFET transistor to realize a synchronous rectifier. Because the commonly used discrete Schottky rectifier is replaced with a low RDS(ON) PMOS switch, the power conversion efficiency reaches 96%. To avoid ground shift due to the high currents in the NMOS switch, two separate ground pins are used. The reference for all control functions is the GND pin. The source of the NMOS switch is connected to PGND. Both grounds must be connected on the PCB at only one point close to the GND pin. A special circuit is applied to disconnect the load from the input during shutdown of the converter. In conventional synchronous rectifier circuits, the backgate diode of the high-side PMOS is forward biased in shutdown and allows current flowing from the battery to the output. This device however uses a special circuit which takes the cathode of the backgate diode of the high-side PMOS and disconnects it from the source when the regulator is not enabled (EN = low).

The benefit of this feature for the system design engineer is that the battery is not depleted during shutdown of the converter. No additional components have to be added to the design to make sure that the battery is disconnected from the output of the converter.

Down Regulation

In general, a boost converter only regulates output voltages which are higher than the input voltage. This device operates differently. For example, it is able to regulate 3.0 V at the output with two fresh alkaline cells at the input having a total cell voltage of 3.2 V. Another example is powering white LEDs with a forward voltage of 3.6 V from a fully charged Li-Ion cell with an output voltage of 4.2 V. To control these applications properly, a down conversion mode is implemented.

If the input voltage reaches or exceeds the output voltage, the converter changes to a down conversion mode. In this mode, the control circuit changes the behavior of the rectifying PMOS. It sets the voltage drop across the PMOS as high as needed to regulate the output voltage. This means the power losses in the converter increase. This has to be taken into account for thermal consideration.

Device Enable

The device is put into operation when EN is set high. It is put into a shutdown mode when EN is set to GND. In shutdown mode, the regulator stops switching, all internal control circuitry including the low-battery comparator is switched off, and the load is isolated from the input (as described in the Synchronous Rectifier Section). This also means that the output voltage can drop below the input voltage during shutdown. During start-up of the converter, the duty cycle and the peak current are limited in order to avoid high peak currents drawn from the battery.

DETAILED DESCRIPTION (continued)

Undervoltage Lockout

An undervoltage lockout function prevents device start-up if the supply voltage on VBAT is lower than approximately 0.8 V. When in operation and the battery is being discharged, the device automatically enters the shutdown mode if the voltage on VBAT drops below approximately 0.8 V. This undervoltage lockout function is implemented in order to prevent the malfunctioning of the converter.

Softstart

When the device enables, the internal startup cycle starts with the first step, the precharge phase. During precharge, the rectifying switch is turned on until the output capacitor is charged to a value close to the input voltage. The rectifying switch is current limited during that phase. This also limits the output current under short circuit conditions at the output. After charging the output capacitor to the input voltage, the device starts switching. If the input voltage is below 1.4 V the device works with a fixed duty cycle of 50% until the output voltage reaches 1.4V. After that the duty cycle is set depending on the input output voltage ratio. Until the output voltage reaches its nominal value, the boost switch current limit is set to 40% of its nominal value to avoid high peak currents at the battery during startup. As soon as the output voltage is reached, the regulator takes control and the switch current limit is set back to 100%.

Power Save Mode

The PS pin can be used to select different operation modes. To enable power save, PS must be set low. Power save mode is used to improve efficiency at light load. In power save mode the converter only operates when the output voltage trips below a set threshold voltage. It ramps up the output voltage with one or several pulses and goes again into power save mode once the output voltage exceeds the set threshold voltage. This power save mode can be disabled by setting the PS to VBAT. In down conversion mode, power save mode is always active and the device cannot be forced into fixed frequency operation at light loads.

Low Battery Detector Circuit—LBI/LBO

The low-battery detector circuit is typically used to supervise the battery voltage and to generate an error flag when the battery voltage drops below a user-set threshold voltage. The function is active only when the device is enabled. When the device is disabled, the LBO pin is high-impedance. The switching threshold is 500 mV at LBI. During normal operation, LBO stays at high impedance when the voltage, applied at LBI, is above the threshold. It is active low when the voltage at LBI goes below 500 mV.

The battery voltage, at which the detection circuit switches, can be programmed with a resistive divider connected to the LBI pin. The resistive divider scales down the battery voltage to a voltage level of 500 mV, which is then compared to the LBI threshold voltage. The LBI pin has a built-in hysteresis of 10 mV. See the application section for more details about the programming of the LBI threshold. If the low-battery detection circuit is not used, the LBI pin should be connected to GND (or to VBAT) and the LBO pin can be left unconnected. Do not let the LBI pin float.

Low-EMI Switch

The device integrates a circuit that removes the ringing that typically appears on the SW node when the converter enters discontinuous current mode. In this case, the current through the inductor ramps to zero and the rectifying PMOS switch is turned off to prevent a reverse current flowing from the output capacitors back to the battery. Due to the remaining energy that is stored in parasitic components of the semiconductor and the inductor, a ringing on the SW pin is induced. The integrated antiringing switch clamps this voltage to VBAT and therefore dampens ringing.

APPLICATION INFORMATION

DESIGN PROCEDURE

The TPS6102x dc/dc converters are intended for systems powered by a single up to triple cell Alkaline, NiCd, NiMH battery with a typical terminal voltage between 0.9 V and 6.5 V. They can also be used in systems powered by one-cell Li-Ion or Li-Polymer with a typical voltage between 2.5 V and 4.2 V. Additionally, any other voltage source with a typical output voltage between 0.9 V and 6.5 V can power systems where the TPS6102x is used.

Programming the Output Voltage

The output voltage of the TPS61020 dc/dc converter can be adjusted with an external resistor divider. The typical value of the voltage at the FB pin is 500 mV. The maximum recommended value for the output voltage is 5.5 V. The current through the resistive divider should be about 100 times greater than the current into the FB pin. The typical current into the FB pin is 0.01 μ A, and the voltage across R4 is typically 500 mV. Based on those two values, the recommended value for R4 should be lower than 500 k Ω , in order to set the divider current at 1 μ A or higher. Because of internal compensation circuitry the value for this resistor should be in the range of 200 k Ω . From that, the value of resistor R3, depending on the needed output voltage (V_O), can be calculated using Equation 1:

$$R3 = R4 \times \left(\frac{V_O}{V_{FB}} - 1 \right) = 180 \text{ k}\Omega \times \left(\frac{V_O}{500 \text{ mV}} - 1 \right) \quad (1)$$

If as an example, an output voltage of 3.3 V is needed, a 1.0-M Ω resistor should be chosen for R3. If for any reason the value for R4 is chosen significantly lower than 200k Ω additional capacitance in parallel to R3 is recommended, in case the device shows instable regulation of the output voltage. The required capacitance value can be easily calculated using Equation 2:

$$C_{\text{par}R3} = 20 \text{ pF} \times \left(\frac{200 \text{ k}\Omega}{R4} - 1 \right) \quad (2)$$

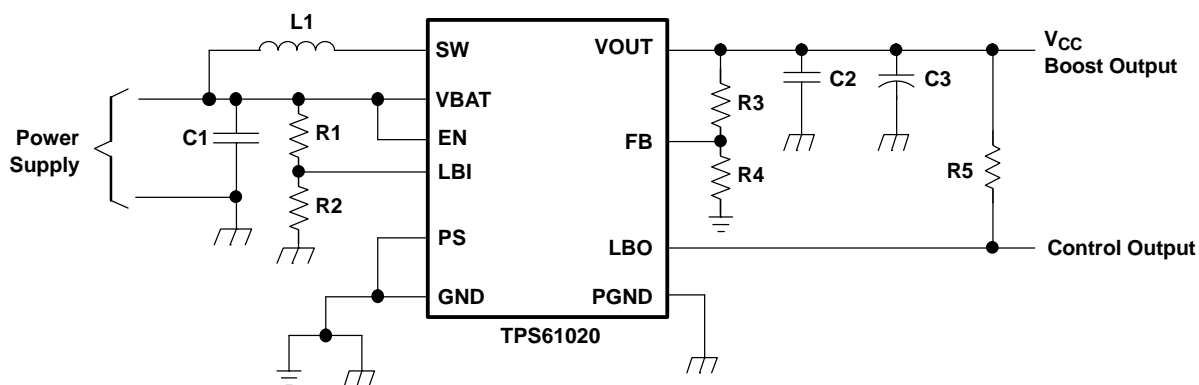

Figure 21. Typical Application Circuit for Adjustable Output Voltage Option

Programming the LBI/LBO Threshold Voltage

The current through the resistive divider should be about 100 times greater than the current into the LBI pin. The typical current into the LBI pin is 0.01 μ A, and the voltage across R2 is equal to the LBI voltage threshold that is generated on-chip, which has a value of 500 mV. The recommended value for R2 is therefore in the range of 500 k Ω . From that, the value of resistor R1, depending on the desired minimum battery voltage V_{BAT} , can be calculated using Equation 3.

$$R1 = R2 \times \left(\frac{V_{BAT}}{V_{LBI - threshold}} - 1 \right) = 390 \text{ k}\Omega \times \left(\frac{V_{BAT}}{500 \text{ mV}} - 1 \right) \quad (3)$$

The output of the low battery supervisor is a simple open-drain output that goes active low if the dedicated battery voltage drops below the programmed threshold voltage on LBI. The output requires a pullup resistor with a recommended value of 1 M Ω . If not used, the LBO pin can be left floating or tied to GND.

Inductor Selection

A boost converter normally requires two main passive components for storing energy during the conversion. A boost inductor and a storage capacitor at the output are required. To select the boost inductor, it is recommended to keep the possible peak inductor current below the current limit threshold of the power switch in the chosen configuration. For example, the current limit threshold of the TPS6102x's switch is 1800 mA at an output voltage of 5 V. The highest peak current through the inductor and the switch depends on the output load, the input (V_{BAT}), and the output voltage (V_{OUT}). Estimation of the maximum average inductor current can be done using Equation 4:

$$I_L = I_{OUT} \times \frac{V_{OUT}}{V_{BAT} \times 0.8} \quad (4)$$

For example, for an output current of 200 mA at 3.3 V, at least 920 mA of average current flows through the inductor at a minimum input voltage of 0.9 V.

The second parameter for choosing the inductor is the desired current ripple in the inductor. Normally, it is advisable to work with a ripple of less than 20% of the average inductor current. A smaller ripple reduces the magnetic hysteresis losses in the inductor, as well as output voltage ripple and EMI. But in the same way, regulation time at load changes rises. In addition, a larger inductor increases the total system costs. With those parameters, it is possible to calculate the value for the inductor by using Equation 5:

$$L = \frac{V_{BAT} \times (V_{OUT} - V_{BAT})}{\Delta I_L \times f \times V_{OUT}} \quad (5)$$

Parameter f is the switching frequency and ΔI_L is the ripple current in the inductor, i.e., 20% $\times I_L$. In this example, the desired inductor has the value of 5.5 μH . With this calculated value and the calculated currents, it is possible to choose a suitable inductor. In typical applications a 6.8 μH inductance is recommended. The device has been optimized to operate with inductance values between 2.2 μH and 22 μH . Nevertheless operation with higher inductance values may be possible in some applications. Detailed stability analysis is then recommended. Care has to be taken that load transients and losses in the circuit can lead to higher currents as estimated in Equation 5. Also, the losses in the inductor caused by magnetic hysteresis losses and copper losses are a major parameter for total circuit efficiency.

The following inductor series from different suppliers have been used with the TPS6102x converters:

Table 3. List of Inductors

VENDOR	INDUCTOR SERIES
Sumida	CDRH4D28
	CDRH5D28
Würth Elektronik	7447789
	744042
EPCOS	B82462-G4
Cooper Electronics Technologies	SD25
	SD20

Capacitor Selection

Input Capacitor

At least a 10- μ F input capacitor is recommended to improve transient behavior of the regulator and EMI behavior of the total power supply circuit. A ceramic capacitor or a tantalum capacitor with a 100-nF ceramic capacitor in parallel, placed close to the IC, is recommended.

Output Capacitor

The major parameter necessary to define the output capacitor is the maximum allowed output voltage ripple of the converter. This ripple is determined by two parameters of the capacitor, the capacitance and the ESR. It is possible to calculate the minimum capacitance needed for the defined ripple, supposing that the ESR is zero, by using Equation 6:

$$C_{\min} = \frac{I_{\text{OUT}} \times (V_{\text{OUT}} - V_{\text{BAT}})}{f \times \Delta V \times V_{\text{OUT}}} \quad (6)$$

Parameter f is the switching frequency and ΔV is the maximum allowed ripple.

With a chosen ripple voltage of 10 mV, a minimum capacitance of 24 μ F is needed. The total ripple is larger due to the ESR of the output capacitor. This additional component of the ripple can be calculated using Equation 7:

$$\Delta V_{\text{ESR}} = I_{\text{OUT}} \times R_{\text{ESR}} \quad (7)$$

An additional ripple of 16 mV is the result of using a tantalum capacitor with a low ESR of 80 m Ω . The total ripple is the sum of the ripple caused by the capacitance and the ripple caused by the ESR of the capacitor. In this example, the total ripple is 26 mV. Additional ripple is caused by load transients. This means that the output capacitor has to completely supply the load during the charging phase of the inductor. A reasonable value of the output capacitance depends on the speed of the load transients and the load current during the load change. With the calculated minimum value of 24 μ F and load transient considerations the recommended output capacitance value is in a 47 to 100 μ F range. For economical reasons, this is usually a tantalum capacitor. Therefore, the control loop has been optimized for using output capacitors with an ESR of above 30 m Ω . The minimum value for the output capacitor is 10 μ F.

Small Signal Stability

When using output capacitors with lower ESR, like ceramics, the adjustable voltage version is recommended. The missing ESR can be compensated in the feedback divider. Typically a capacitor in the range of 4.7 pF in parallel to R3 helps to obtain small signal stability with lowest ESR output capacitors. For more detailed analysis, the small signal transfer function of the error amplifier and the regulator, which is given in Equation 8, can be used:

$$A_{\text{REG}} = \frac{d}{V_{\text{FB}}} = \frac{4 \times (R3 + R4)}{R4 \times (1 + i \times \omega \times 0.9 \mu\text{s})} \quad (8)$$

Layout Considerations

As for all switching power supplies, the layout is an important step in the design, especially at high peak currents and high switching frequencies. If the layout is not carefully done, the regulator could show stability problems as well as EMI problems. Therefore, use wide and short traces for the main current path and for the power ground tracks. The input capacitor, output capacitor, and the inductor should be placed as close as possible to the IC. Use a common ground node for power ground and a different one for control ground to minimize the effects of ground noise. Connect these ground nodes at any place close to one of the ground pins of the IC.

The feedback divider should be placed as close as possible to the control ground pin of the IC. To lay out the control ground, it is recommended to use short traces as well, separated from the power ground traces. This avoids ground shift problems, which can occur due to superimposition of power ground current and control ground current.

APPLICATION EXAMPLES

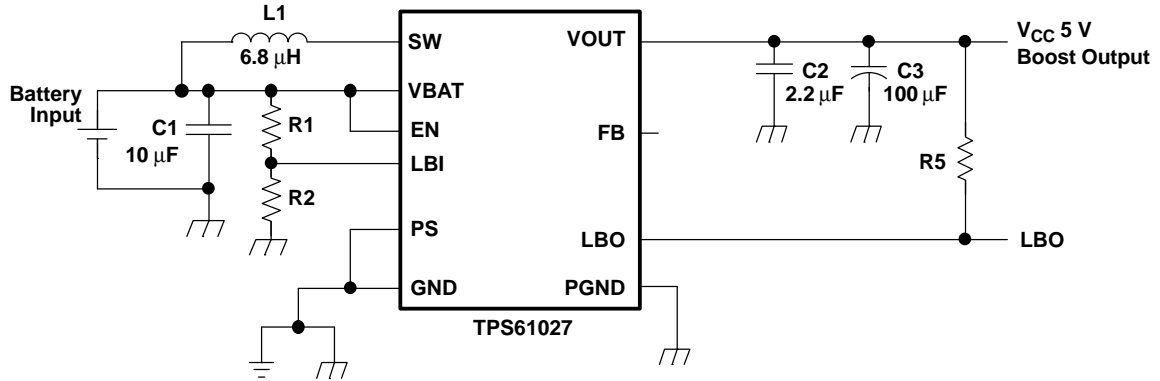

- List of Components:**
 U1 = TPS61027DRC
 L1 = EPCOS B82462-G4682
 C1, C2 = X7R,X5R Ceramic
 C3 = Low ESR Tantalum

Figure 22. Power Supply Solution for Maximum Output Power Operating from a Single Alkaline Cell

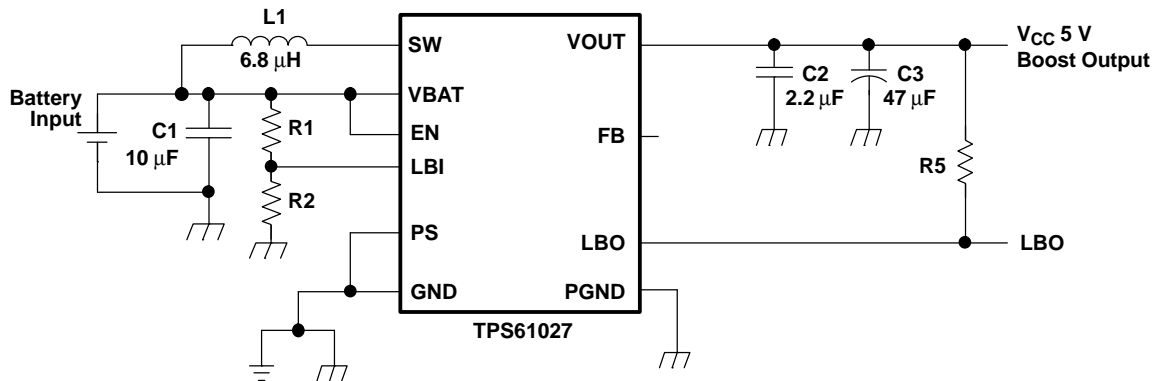

- List of Components:**
 U1 = TPS61027DRC
 L1 = EPCOS B82462-G4682
 C1, C2 = X7R,X5R Ceramic
 C3 = Low ESR Tantalum

Figure 23. Power Supply Solution for Maximum Output Power Operating from a Dual/Triple Alkaline Cell or Single Li-Ion Cell

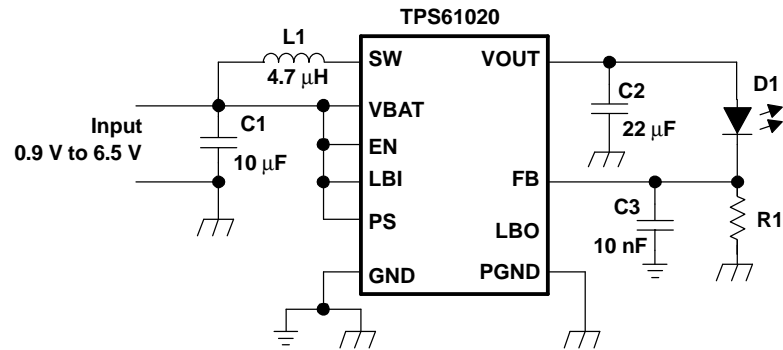

- List of Components:
 U1 = TPS61020DRC
 L1 = Sumida CDRH2D16-4R7
 C1, C2, C3 = X7R, X5R Ceramic
 D1 = White LED

Figure 24. Power Supply Solution for Powering White LED's in Lighting Applications

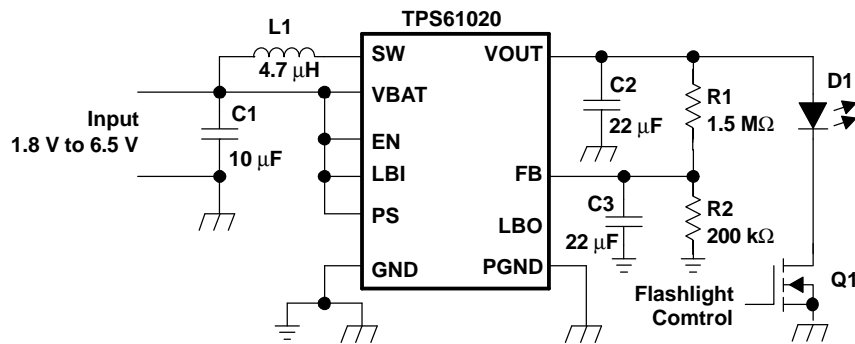

- List of Components:
 U1 = TPS61020DRC
 L1 = TDK VLF3010AT 4R7MR70
 C1, C2, C3 = X7R, X5R Ceramic
 D1 = OSRAM LWW57G
 Q1 = Vishay SI1012R

Figure 25. Simple Power Supply Solution for Powering White LED Flashlights

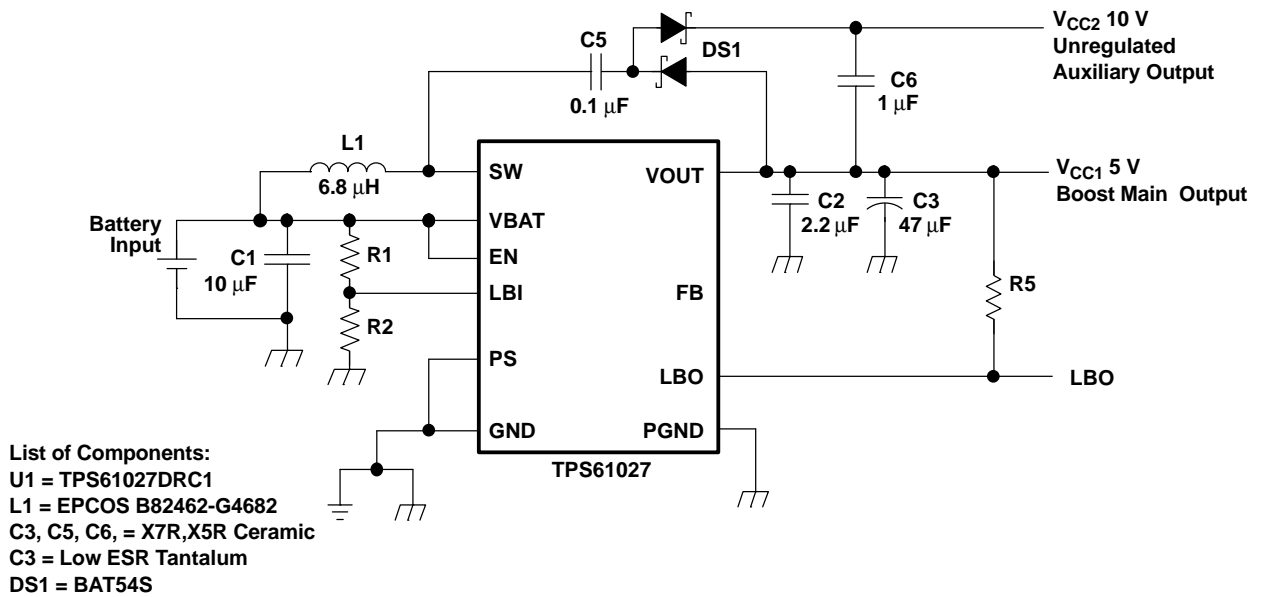

Figure 26. Power Supply Solution With Auxiliary Positive Output Voltage

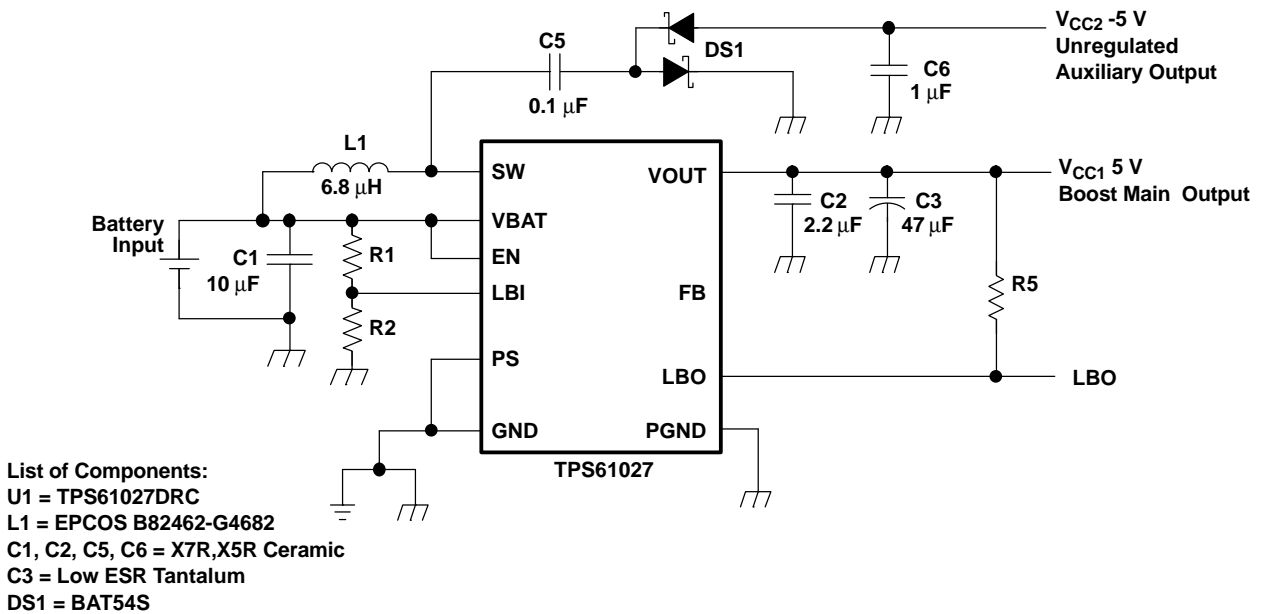

Figure 27. Power Supply Solution With Auxiliary Negative Output Voltage

THERMAL INFORMATION

Implementation of integrated circuits in low-profile and fine-pitch surface-mount packages typically requires special attention to power dissipation. Many system-dependent issues such as thermal coupling, airflow, added heat sinks and convection surfaces, and the presence of other heat-generating components affect the power-dissipation limits of a given component.

Three basic approaches for enhancing thermal performance are listed below.

- Improving the power dissipation capability of the PCB design
- Improving the thermal coupling of the component to the PCB
- Introducing airflow in the system

The maximum recommended junction temperature (T_J) of the TPS6102x devices is 125°C. The thermal resistance of the 10-pin QFN 3 x 3 package (DRC) is $R_{\theta JA} = 48.7$ °C/W, if the PowerPAD is soldered. Specified regulator operation is assured to a maximum ambient temperature T_A of 85°C. Therefore, the maximum power dissipation is about 820 mW. More power can be dissipated if the maximum ambient temperature of the application is lower.

$$P_{D(MAX)} = \frac{T_{J(MAX)} - T_A}{R_{\theta JA}} = \frac{125^\circ\text{C} - 85^\circ\text{C}}{48.7^\circ\text{C/W}} = 820 \text{ mW} \quad (9)$$

MECHANICAL DATA

MPDS117A FEBRUARY 2002 – REVISED MAY 2002

DRC (S-PDSO-N10)

CUSTOM DEVICE

PLASTIC SMALL OUTLINE

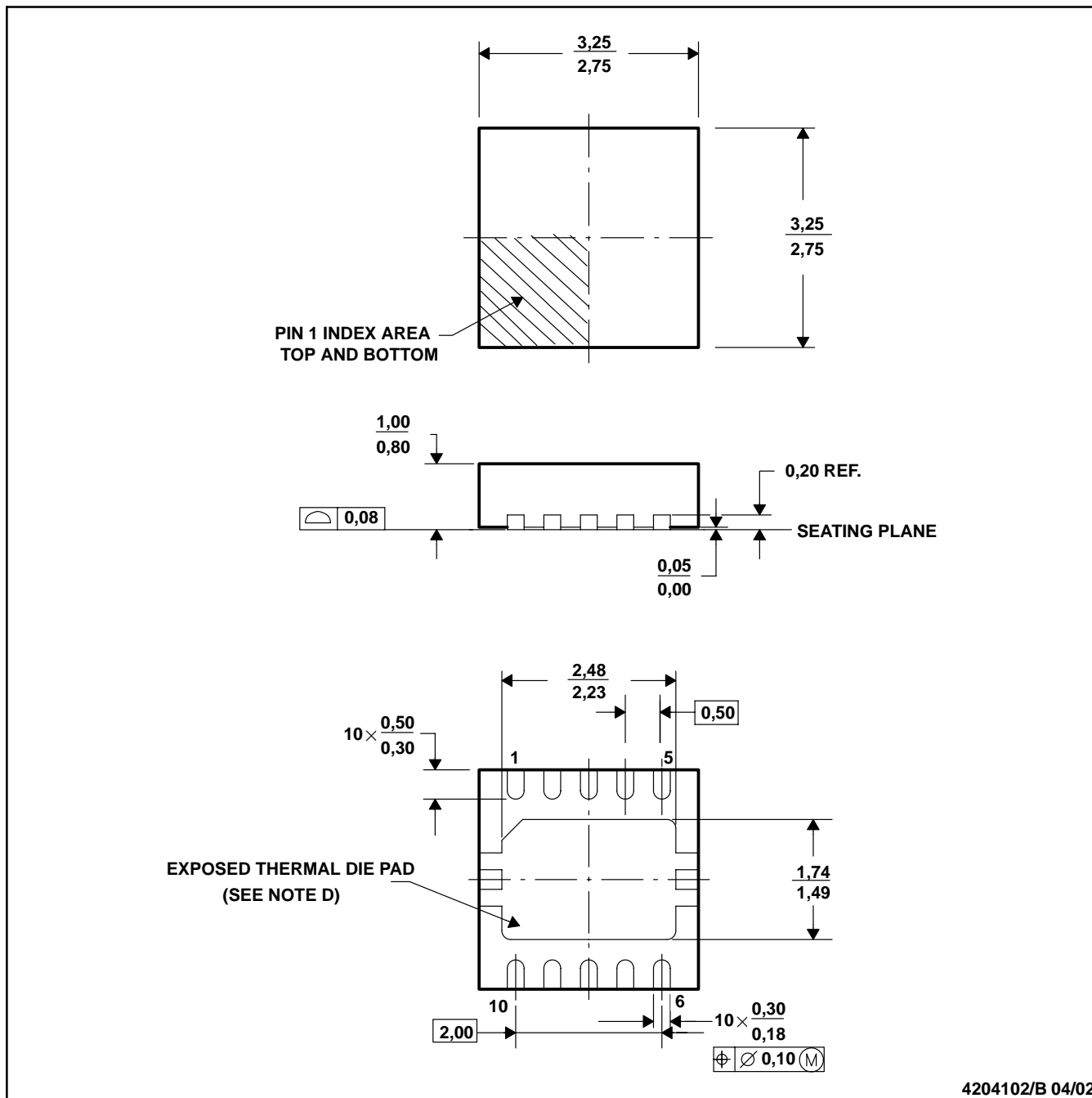

4204102/B 04/02

- NOTES:
- A. All linear dimensions are in millimeters.
 - B. This drawing is subject to change without notice.
 - C. Small Outline No-Lead (SON) package configuration.
 - D. The package thermal performance may be enhanced by bonding the thermal die pad to an external thermal plane.

IMPORTANT NOTICE

Texas Instruments Incorporated and its subsidiaries (TI) reserve the right to make corrections, modifications, enhancements, improvements, and other changes to its products and services at any time and to discontinue any product or service without notice. Customers should obtain the latest relevant information before placing orders and should verify that such information is current and complete. All products are sold subject to TI's terms and conditions of sale supplied at the time of order acknowledgment.

TI warrants performance of its hardware products to the specifications applicable at the time of sale in accordance with TI's standard warranty. Testing and other quality control techniques are used to the extent TI deems necessary to support this warranty. Except where mandated by government requirements, testing of all parameters of each product is not necessarily performed.

TI assumes no liability for applications assistance or customer product design. Customers are responsible for their products and applications using TI components. To minimize the risks associated with customer products and applications, customers should provide adequate design and operating safeguards.

TI does not warrant or represent that any license, either express or implied, is granted under any TI patent right, copyright, mask work right, or other TI intellectual property right relating to any combination, machine, or process in which TI products or services are used. Information published by TI regarding third-party products or services does not constitute a license from TI to use such products or services or a warranty or endorsement thereof. Use of such information may require a license from a third party under the patents or other intellectual property of the third party, or a license from TI under the patents or other intellectual property of TI.

Reproduction of information in TI data books or data sheets is permissible only if reproduction is without alteration and is accompanied by all associated warranties, conditions, limitations, and notices. Reproduction of this information with alteration is an unfair and deceptive business practice. TI is not responsible or liable for such altered documentation.

Resale of TI products or services with statements different from or beyond the parameters stated by TI for that product or service voids all express and any implied warranties for the associated TI product or service and is an unfair and deceptive business practice. TI is not responsible or liable for any such statements.

Following are URLs where you can obtain information on other Texas Instruments products and application solutions:

Products		Applications	
Amplifiers	amplifier.ti.com	Audio	www.ti.com/audio
Data Converters	dataconverter.ti.com	Automotive	www.ti.com/automotive
DSP	dsp.ti.com	Broadband	www.ti.com/broadband
Interface	interface.ti.com	Digital Control	www.ti.com/digitalcontrol
Logic	logic.ti.com	Military	www.ti.com/military
Power Mgmt	power.ti.com	Optical Networking	www.ti.com/opticalnetwork
Microcontrollers	microcontroller.ti.com	Security	www.ti.com/security
		Telephony	www.ti.com/telephony
		Video & Imaging	www.ti.com/video
		Wireless	www.ti.com/wireless

Mailing Address: Texas Instruments
Post Office Box 655303 Dallas, Texas 75265