

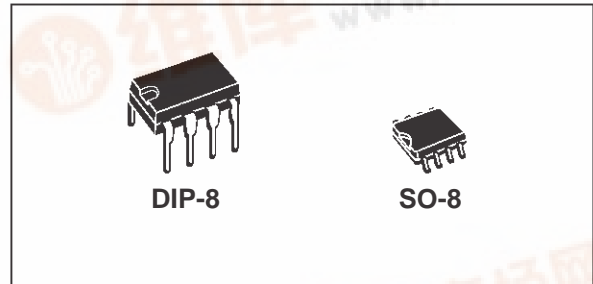

ST755

ADJUSTABLE INVERTING NEGATIVE OUTPUT CURRENT MODE PWM REGULATORS

- 2.7V TO 11V INPUT TO ADJUSTABLE NEGATIVE OUTPUT CONVERSION
- 1W GUARANTEED OUTPUT POWER ($V_{in} > 4.5V, T \leq 70^{\circ}C$)
- 68% TYP. EFFICIENCY AT 6V
- VERY LOW QUIESCENT CURRENT: 1.2mA IN ON MODE 10 μ A IN SHUT DOWN MODE
- SOFT START
- VERY LOW NOISE OUTPUT
- 160KHz FIXED FREQUENCY OSCILLATOR
- MIXED BIPOLAR-CMOS TECHNOLOGY



$V_{in} > 4.5V, V_{out} = -5V$ and $0^{\circ}C \leq T_a \leq 70^{\circ}C$) and 275mA (typical value at $T_a = 25^{\circ}C, V_{out} = -5V$).
 A logic controlled shut down pin that interfaces directly with microprocessor reduces supply current to only 10 μ A. Input to Output differential voltage is limited to $V_{in} + |V_{out}| < 12.7V$. No load supply current is 1.2mA.

DESCRIPTION

The ST755 is an adjustable inverting switch-mode DC-DC regulator with internal Power MOSFET that generates an adjustable negative output from a voltage input of 2.7V to 11V, output current guaranteed at 200mA (for

BLOCK DIAGRAM

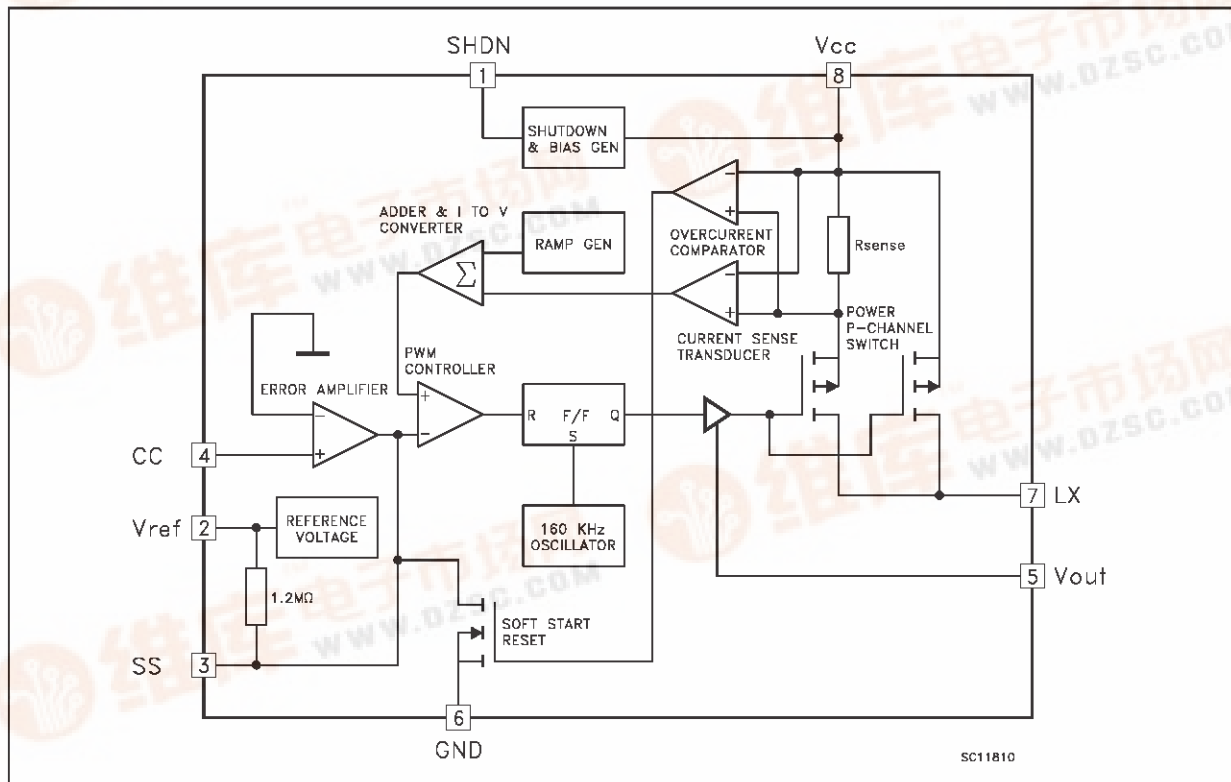

ST755

ABSOLUTE MAXIMUM RATINGS

Symbol	Parameter	Value	Unit
V_{CC}	DC Input Voltage to GND	-0.3 to 12	V
SHDN	Shutdown Voltage	-0.3 to $V_{CC}+0.3$	V
	Other Input Voltage	-0.3 to $V_{CC}+0.3$	V
I_{LX}	Peak Switch Current	2	A
P_{tot}	Power Dissipation (at 70°C) (for DIP-8) (for SO-8)	725 470	mW
T_{op}	Operating Ambient Temperature Range	-40 to 85	°C
T_{stg}	Storage Temperature Range	-55 to 150	°C

Absolute Maximum Rating are those values beyond which damage to the device may occur. Functional operation under these condition is not implied.

CONNECTION DIAGRAM AND (top view)

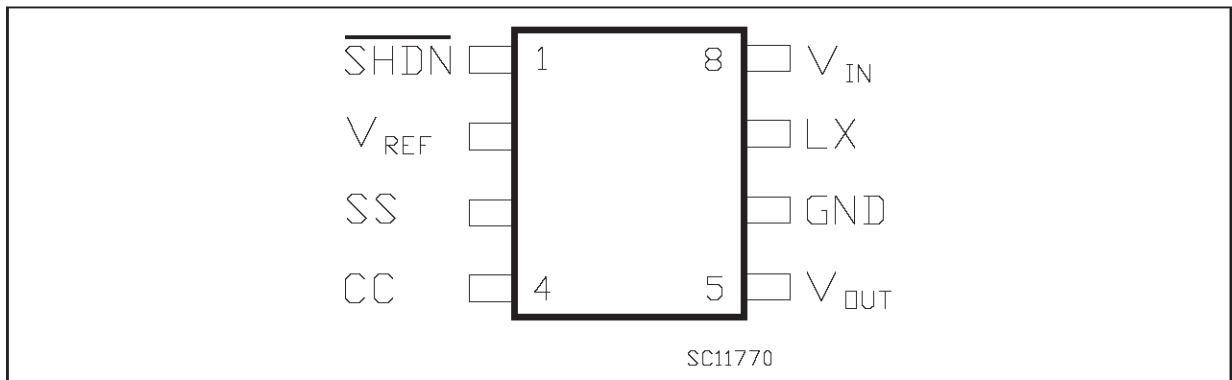

PIN CONNECTIONS

Pin No	Symbol	Name and Function
1	SHDN	SHUT-DOWN Control (V_{CC} = On, GND=Shutdown)
2	V_{ref}	Reference Output Voltage (1.25V)
3	SS	Soft Start
4	CC	Compensation Input
5	V_{out}	Negative Output Voltage
6	GND	Ground
7	LX	Switch Output
8	V_{CC}	Positive Supply-Voltage Input

ORDERING NUMBERS

Type	DIP-8	SO-8 (Tube)	SO-8 (T&R)
ST755	ST755CN	ST755CD	ST755CD-TR

ELECTRICAL CHARACTERISTICS (Refer to the test circuits, $V_{CC} = 5V$, $V_{out} = -5.25$ to $-4.75V$, $I_{load} = 0mA$, $T_a = T_{min}$ to T_{max} unless otherwise specified. Typical Value are referred at $T_a = 25^\circ C$)

Symbol	Parameter	Test Conditions	Min.	Typ.	Max.	Unit
V_{IN}	Input Voltage		2.7		11	V
V_o	Output Voltage	$I_o = 0$ mA to 200 mA $V_{CC} = 4.5$ to 6.2 V	-5.25	-5	-4.75	V
I_o	Output Current	$V_{CC} = 4.5$ to 6.2 V $T_a = 0^\circ C$ to $70^\circ C$ $V_{CC} = 4.5$ to 6.2 V $T_a = -40^\circ C$ to $85^\circ C$ $V_{CC} = 4$ V $V_{out} = -5$ V $V_{CC} = 2.7$ V $V_{out} = -5$ V	200 175	275 175 125		mA mA mA mA
I_{SUPPLY}	Supply Current (Including Switching Current)	No Load, $V_{SHDN} = V_{CC}$		1.2	3.5	mA
I_{OFF}	Standby Current	No Load, $V_{SHDN} = 0V$		10	100	μA
I_{SC}	Short Circuit Current			1.2		A
ΔV_o	Line Regulation	$V_{CC} = 4$ to 6.2 V		0.1		%/V
ΔV_o	Load Regulation	$I_o = 0$ mA to 200 mA		0.003		%/mA
V_{REF}	Reference Voltage	$T_a = 25^\circ C$	1.18	1.25	1.32	V
ΔV_{REF}	Reference Drift	$T_a = T_{min}$ to T_{max}		50		ppm/ $^\circ C$
R_{DSON}	LX On Resistance			0.7		Ω
I_{LEAK}	LX Leakage Current	$V_{DS} = 10$ V		1		μA
I_{SH}	Shutdown Pin Current				1	μA
V_{il}	Shutdown Input Low Threshold				0.25	V
V_{ih}	Shutdown Input High Threshold		2			V
f_o	Oscillator Frequency			160		KHz
η	Power Efficiency	$I_o = 100$ mA		68		%
CC	Compensation Pin Impedance			7.5		K Ω

Do not overload or short the Output to Ground. If the above conditions are observed, the device may be damaged.

APPLICATION INFORMATION

The ST755 is an IC developed for voltage conversion from an input voltage ranging from +2.4V to 11V to a regulated adjustable negative output limited by $|V_{out}| \leq 12.7V - V_{IN}$. The circuit adopts a current-mode PWM control scheme to achieve good efficiency, high stability and low noise performance. The figure in the first page shown the detailed block diagram of the device. ST755 is realized in a BCD technology in order to achieve high temperature stability, the best REFERENCE precision, a very low quiescent current and jitter free operations. The final stage is built around a 0.7Ω - 2A P-Channel Power MOS. A fraction of the output current is splitted out for current detection. Internal clock frequency is fixed to 160KHz. Error amplifier drives the

PWM comparator in order to keep 0V on the CC input. So R_3 and R_4 resistors are calculated by the following formulae $R_4 = (|V_{out}|/V_{ref}) * R_3$ (see fig 1). For R_3 can be chosen any value between 2K Ω and 20K Ω . Soft-Start (SS) input is a voltage dependent-output current limit (see figure 9, Switch Current Limit vs. SS Input Voltage). SS pin is internally pulled to V_{ref} through a 1.2 M Ω resistor. Applying an appropriate capacitor at SS input is possible to obtain a soft-start current limitation during power up. Forcing Soft-Start (SS) input to a lower voltage through a resistive voltage divider (R_1 and R_2), the maximum LX current limit can be lowered according the diagram showed in figure 9. When SHDN input is low, the total current consumption is reduced to 10 μA .

APPLICATION CIRCUIT

To achieve the best performances from switching power supply topology, particular care to layout drawing is needed, in order to minimize EMI and obtain low noise, jitter free operation moreover, it ensures the full device functionality. Layout design proposed on demoboard (see picture 2) helps to lower the developing time.

Wire lengths must be minimized, filter and by-pass capacitors C₁, C₂ and C₃ must be low ESR type, placed as close possible to the integrated circuit. The 10µH inductor must be chosen built on a core, taking care that saturation current should be higher than the peak LX switch current. See the PEAK INDUCTOR CURRENT vs. LOAD CURRENT graph (figure 6)

Figure 1: TYPICAL APPLICATION CIRCUIT

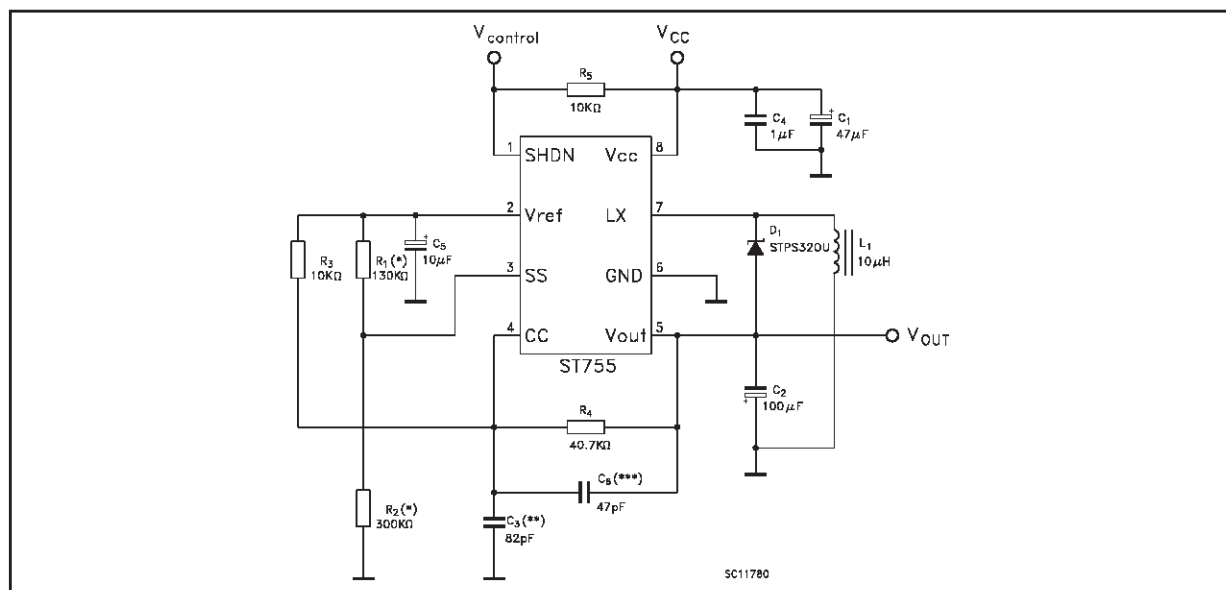

(*) R1 and R2 can be omitted for I_{out}<200mA.
 (**) C6: Very low noise but poor transient and load response speed.
 (***) C3 (alternative to C6): faster transient and load response.

Figure 2: Printed Demoboard

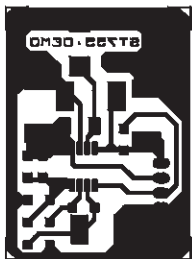

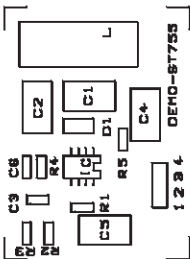

Symbol	Pin
V _{cc}	1
V _{out}	2
SHDN	3
GND	4

Component Values

Capacitor	Value	Unit	Resistor	Value	Unit
C1	47	µF	R1	130	KΩ
C2	100	µF	R2	300	KΩ
C3	82	pF	R3	10	KΩ
C4	1	µF	R4	40.7	KΩ
C5	10	µF	R5	10	KΩ
C6	47	pF			

TYPICAL OPERATING CHARACTERISTICS

Figure 3: Load Current vs Supply Voltage

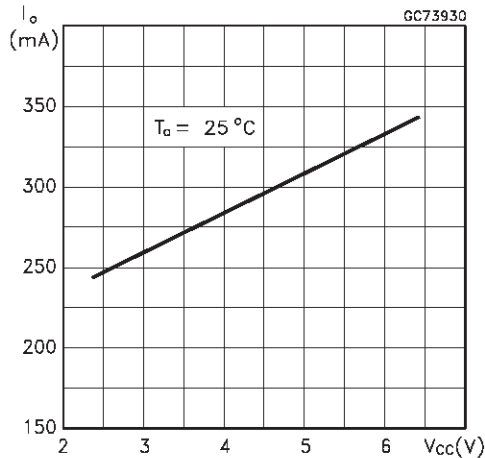

Figure 4: Load Current vs Supply Voltage

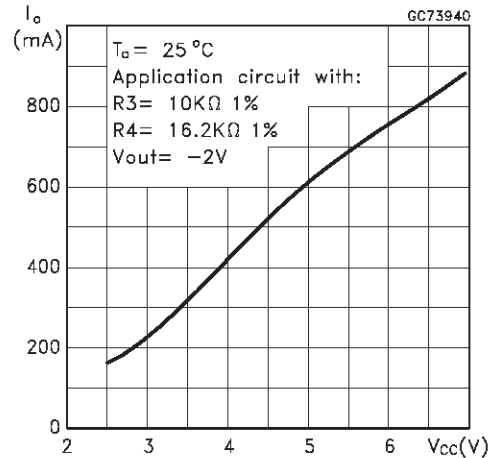

Figure 5: Efficiency vs Load Current

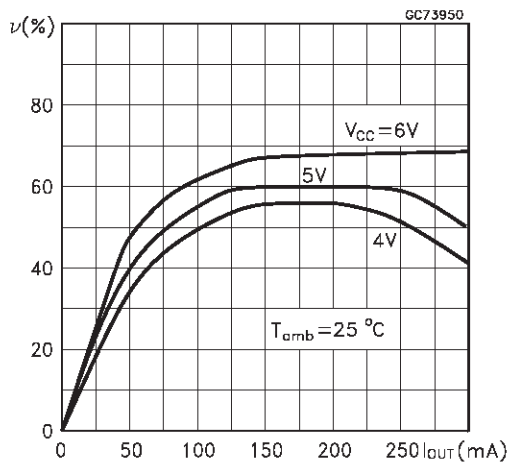

Figure 6: Peak Inductor Current vs Load Current

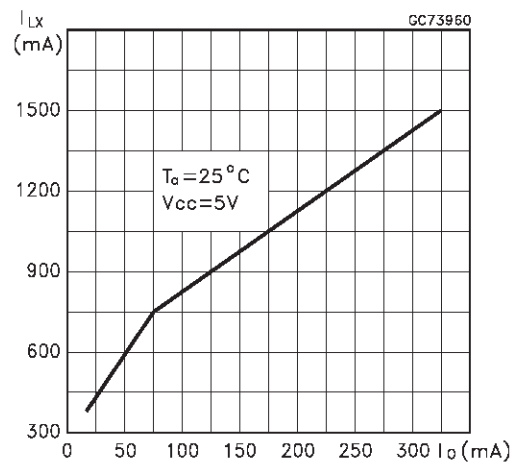

Figure 7: Switch ON Resistance vs Supply Voltage

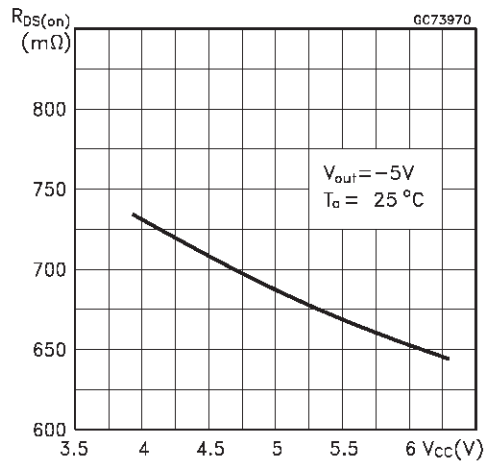
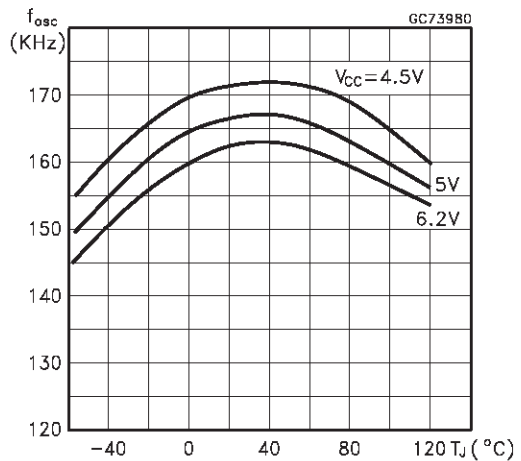

Figure 8: Oscillator Frequency vs Temperature & Supply Voltage



TYPICAL OPERATING CHARACTERISTICS (continued)

Figure 9: Switch Current Limit vs Soft Start Voltage

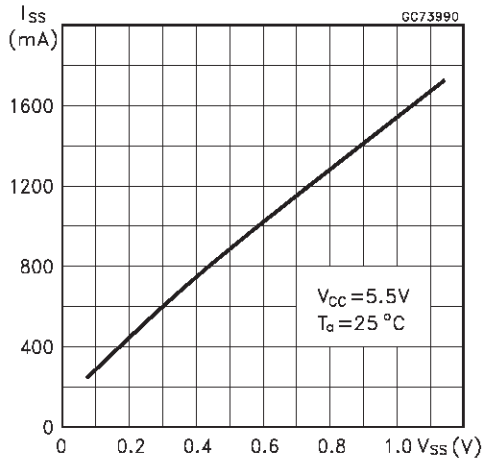

Figure 10: Reference Voltage vs temperature

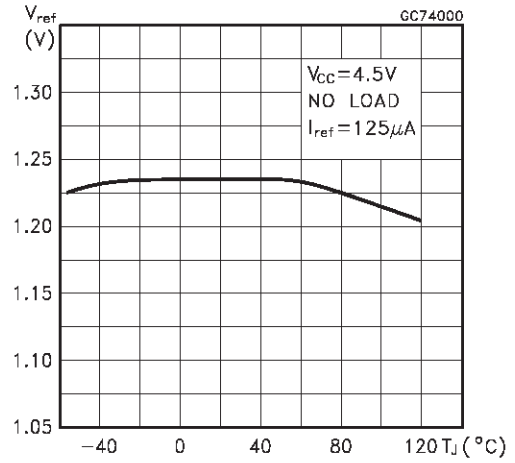
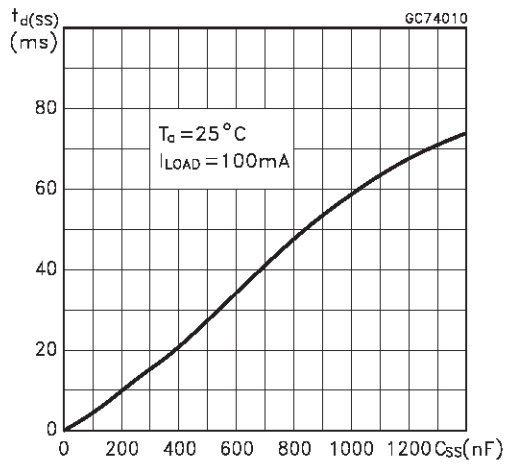
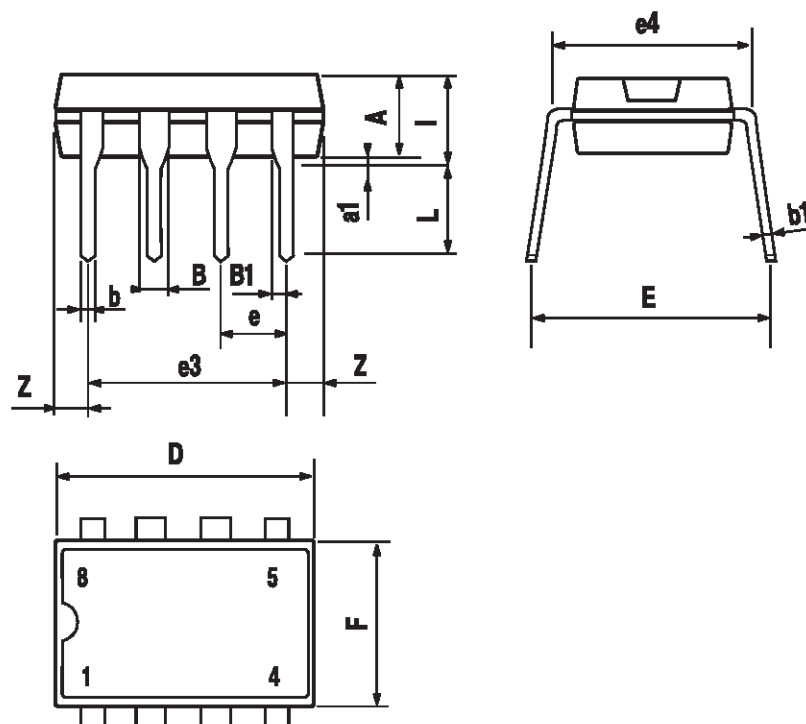

Figure 11: Soft Start Delay Time



Plastic DIP-8 MECHANICAL DATA

DIM.	mm			inch		
	MIN.	TYP.	MAX.	MIN.	TYP.	MAX.
A		3.3			0.130	
a1	0.7			0.028		
B	1.39		1.65	0.055		0.065
B1	0.91		1.04	0.036		0.041
b		0.5			0.020	
b1	0.38		0.5	0.015		0.020
D			9.8			0.386
E		8.8			0.346	
e		2.54			0.100	
e3		7.62			0.300	
e4		7.62			0.300	
F			7.1			0.280
l			4.8			0.189
L		3.3			0.130	
Z	0.44		1.6	0.017		0.063



P001F

SO-8 MECHANICAL DATA

DIM.	mm			inch		
	MIN.	TYP.	MAX.	MIN.	TYP.	MAX.
A			1.75			0.068
a1	0.1		0.25	0.003		0.009
a2			1.65			0.064
a3	0.65		0.85	0.025		0.033
b	0.35		0.48	0.013		0.018
b1	0.19		0.25	0.007		0.010
C	0.25		0.5	0.010		0.019
c1	45 (typ.)					
D	4.8		5.0	0.188		0.196
E	5.8		6.2	0.228		0.244
e		1.27			0.050	
e3		3.81			0.150	
F	3.8		4.0	0.14		0.157
L	0.4		1.27	0.015		0.050
M			0.6			0.023
S	8 (max.)					

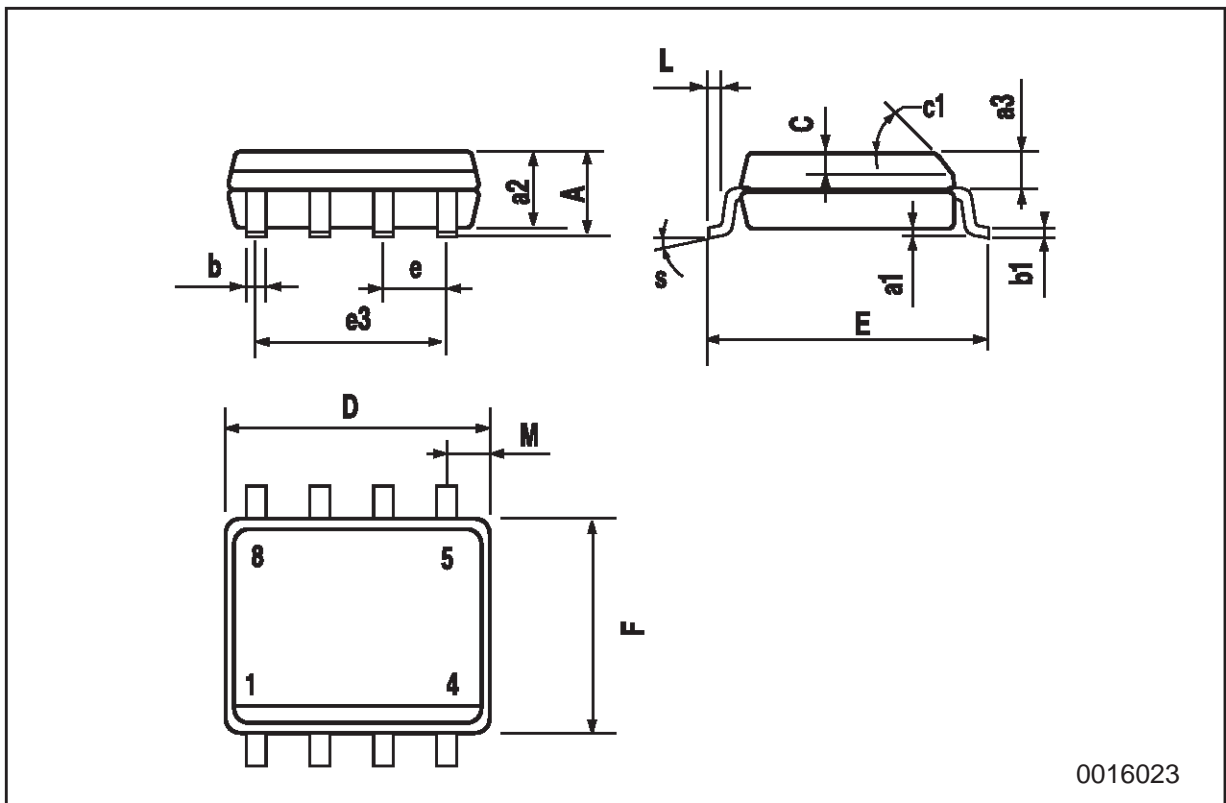

0016023

Information furnished is believed to be accurate and reliable. However, STMicroelectronics assumes no responsibility for the consequences of use of such information nor for any infringement of patents or other rights of third parties which may result from its use. No license is granted by implication or otherwise under any patent or patent rights of STMicroelectronics. Specification mentioned in this publication are subject to change without notice. This publication supersedes and replaces all information previously supplied. STMicroelectronics products are not authorized for use as critical components in life support devices or systems without express written approval of STMicroelectronics.

The ST logo is a trademark of STMicroelectronics

© 1998 STMicroelectronics – Printed in Italy – All Rights Reserved

STMicroelectronics GROUP OF COMPANIES

Australia - Brazil - Canada - China - France - Germany - Italy - Japan - Korea - Malaysia - Malta - Mexico - Morocco - The Netherlands - Singapore - Spain - Sweden - Switzerland - Taiwan - Thailand - United Kingdom - U.S.A.

