

IS61(64)LF12832A IS64VF12832A
 IS61(64)LF12836A IS61(64)VF12836A
 IS61(64)LF25618A IS61(64)VF25618A



128K x 32, 128K x 36, 256K x 18 4 Mb SYNCHRONOUS FLOW-THROUGH STATIC RAM

PRELIMINARY INFORMATION
 AUGUST 2005

FEATURES

- Internal self-timed write cycle
- Individual Byte Write Control and Global Write
- Clock controlled, registered address, data and control
- Burst sequence control using MODE input
- Three chip enable option for simple depth expansion and address pipelining
- Common data inputs and data outputs
- Auto Power-down during deselect
- Single cycle deselect
- Snooze MODE for reduced-power standby
- Power Supply
 LF: $V_{DD} 3.3V \pm 5\%$, $V_{DDQ} 3.3V/2.5V \pm 5\%$
 VF: $V_{DD} 2.5V -5\% +10\%$, $V_{DDQ} 2.5V -5\% +10\%$
- JEDEC 100-Pin TQFP, 119-pin PBGA, and 165-pin PBGA packages
- Automotive temperature available
- Lead-free available

DESCRIPTION

The ISSI IS61(64)LF12832A, IS64VF12832A, IS61(64)LF/VF12836A and IS61(64)LF/VF25618A are high-speed, low-power synchronous static RAMs designed to provide burstable, high-performance memory for communication and networking applications. The IS61(64)LF12832A is organized as 131,072 words by 32 bits. The IS61(64)LF/VF12836A is organized as 131,072 words by 36 bits. The IS61(64)LF/VF25618A is organized as 262,144 words by 18 bits. Fabricated with ISSI's advanced CMOS technology, the device integrates a 2-bit burst counter, high-speed SRAM core, and high-drive capability outputs into a single monolithic circuit. All synchronous inputs pass through registers controlled by a positive-edge-triggered single clock input.

Write cycles are internally self-timed and are initiated by the rising edge of the clock input. Write cycles can be one to four bytes wide as controlled by the write control inputs.

Separate byte enables allow individual bytes to be written. Byte write operation is performed by using byte write enable (**BWE**) input combined with one or more individual byte write signals (**BWx**). In addition, Global Write (**GW**) is available for writing all bytes at one time, regardless of the byte write controls.

Bursts can be initiated with either **ADSP** (Address Status Processor) or **ADSC** (Address Status Cache Controller) input pins. Subsequent burst addresses can be generated internally and controlled by the **ADV** (burst address advance) input pin.

The mode pin is used to select the burst sequence order, Linear burst is achieved when this pin is tied LOW. Interleave burst is achieved when this pin is tied HIGH or left floating.

FAST ACCESS TIME

Symbol	Parameter	-6.5	-7.5	Units
tkQ	Clock Access Time	6.5	7.5	ns
tkC	Cycle Time	7.5	8.5	ns
	Frequency	133	117	MHz

BLOCK DIAGRAM

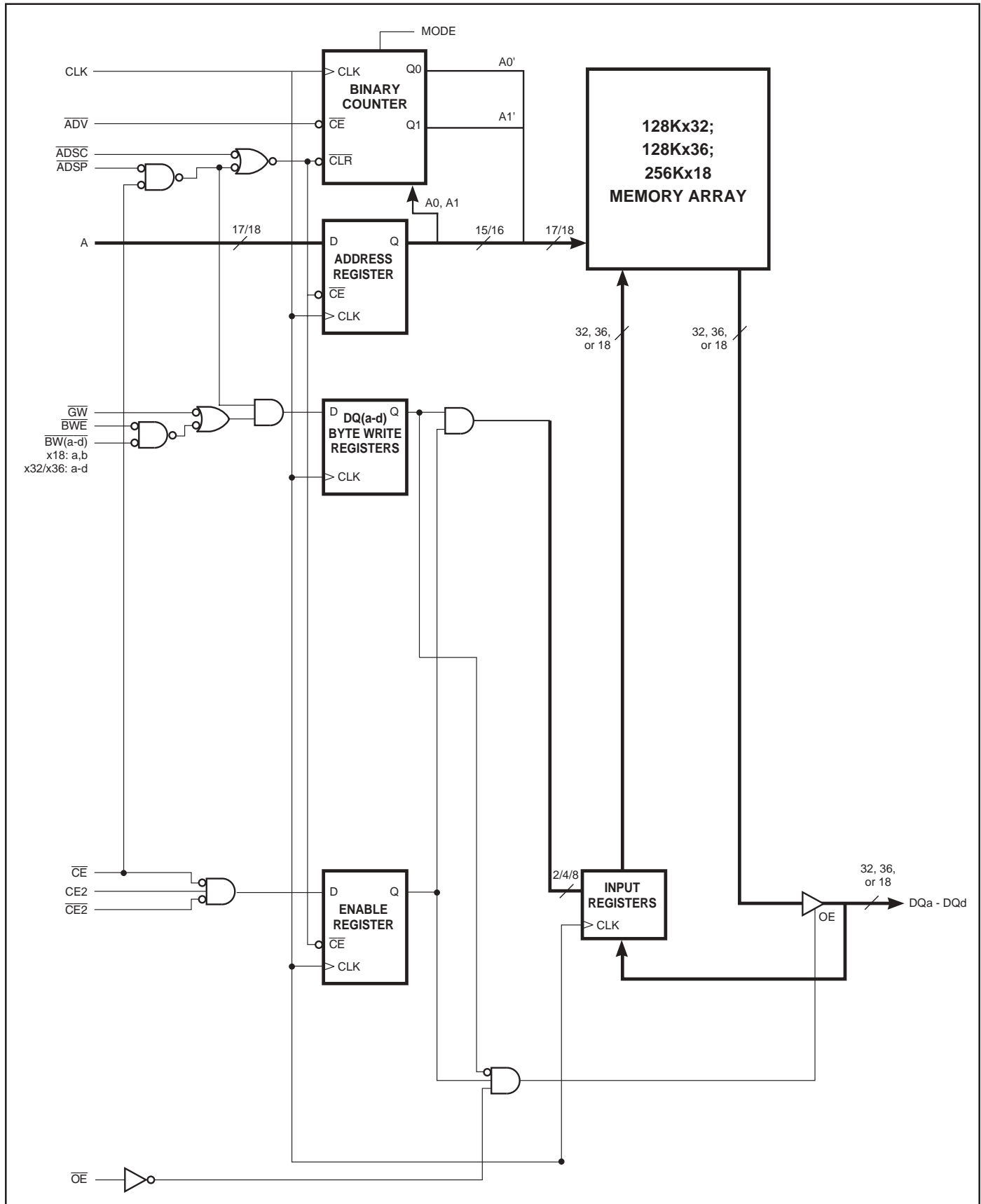

IS61(64)LF12832A, IS61(64)LF12836A, IS61(64)LF25618A
IS64VF12832A, IS61(64)VF12836A, IS61(64)VF25618A



165-PIN BGA

165-Ball, 13x15 mm BGA

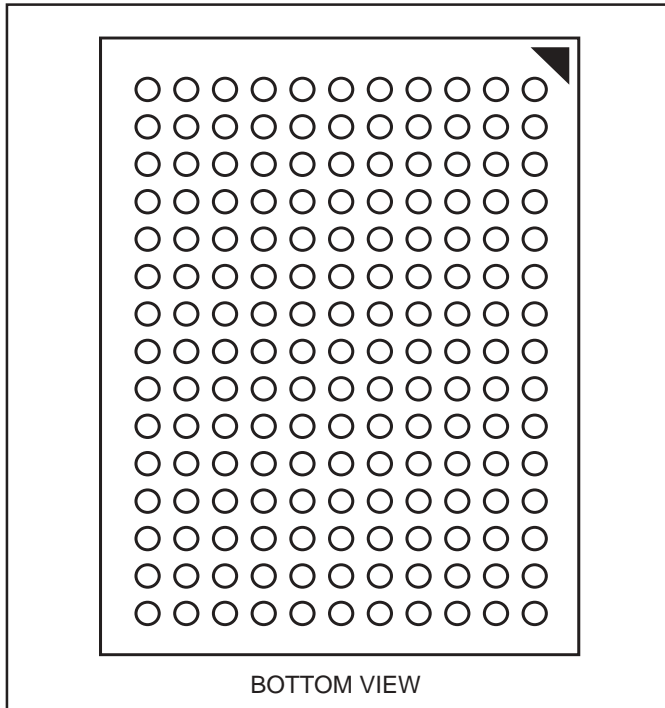

119-PIN BGA

119-Ball, 14x22 mm BGA

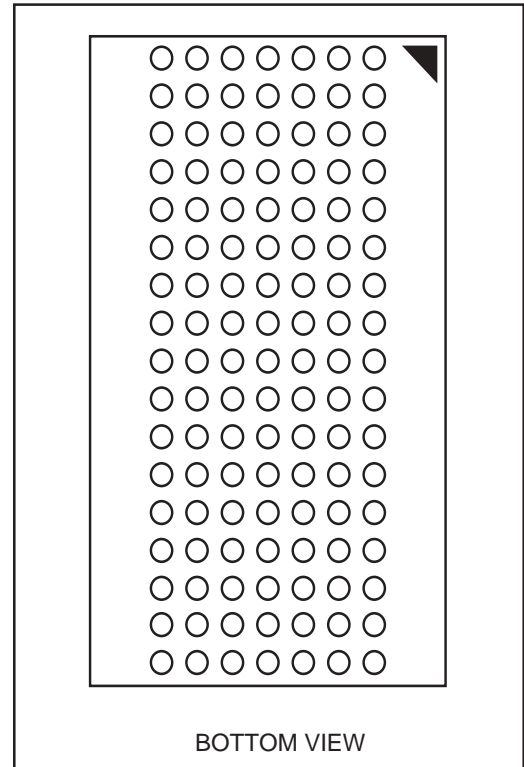

119 BGA PACKAGE PIN CONFIGURATION

128K x 36 (TOP VIEW)

	1	2	3	4	5	6	7
A	V _{DDQ}	A	A	$\overline{\text{ADSP}}$	A	A	V _{DDQ}
B	NC	CE2	A	$\overline{\text{ADSC}}$	A	$\overline{\text{CE2}}$	NC
C	NC	A	A	V _{DD}	A	A	NC
D	DQ _c	DQP _c	V _{SS}	NC	V _{SS}	DQP _b	DQ _b
E	DQ _c	DQ _c	V _{SS}	$\overline{\text{CE}}$	V _{SS}	DQ _b	DQ _b
F	V _{DDQ}	DQ _c	V _{SS}	$\overline{\text{OE}}$	V _{SS}	DQ _b	V _{DDQ}
G	DQ _c	DQ _c	$\overline{\text{BWc}}$	$\overline{\text{ADV}}$	$\overline{\text{BWb}}$	DQ _b	DQ _b
H	DQ _c	DQ _c	V _{SS}	$\overline{\text{GW}}$	V _{SS}	DQ _b	DQ _b
J	V _{DDQ}	V _{DD}	NC	V _{DD}	NC	V _{DD}	V _{DDQ}
K	DQ _d	DQ _d	V _{SS}	CLK	V _{SS}	DQ _a	DQ _a
L	DQ _d	DQ _d	$\overline{\text{BWd}}$	NC	$\overline{\text{BWa}}$	DQ _a	DQ _a
M	V _{DDQ}	DQ _d	V _{SS}	$\overline{\text{BWE}}$	V _{SS}	DQ _a	V _{DDQ}
N	DQ _d	DQ _d	V _{SS}	A ₁ *	V _{SS}	DQ _a	DQ _a
P	DQ _d	DQP _d	V _{SS}	A ₀ *	V _{SS}	DQP _a	DQ _a
R	NC	A	MODE	V _{DD}	NC	A	NC
T	NC	NC	A	A	A	NC	ZZ
U	V _{DDQ}	NC	NC	NC	NC	NC	V _{DDQ}

Note: * A₀ and A₁ are the two least significant bits (LSB) of the address field and set the internal burst counter if burst is desired.

PIN DESCRIPTIONS

Symbol	Pin Name
A	Address Inputs
A0, A1	Synchronous Burst Address Inputs
$\overline{\text{ADV}}$	Synchronous Burst Address Advance
$\overline{\text{ADSP}}$	Address Status Processor
$\overline{\text{ADSC}}$	Address Status Controller
$\overline{\text{GW}}$	Global Write Enable
CLK	Synchronous Clock
$\overline{\text{CE}}, \overline{\text{CE2}}, \overline{\text{CE2}}$	Synchronous Chip Select
$\overline{\text{BW}}_x$ (x=a-d)	Synchronous Byte Write Controls
$\overline{\text{BWE}}$	Byte Write Enable

Symbol	Pin Name
$\overline{\text{OE}}$	Output Enable
ZZ	Power Sleep Mode
MODE	Burst Sequence Selection
NC	No Connect
DQ _a -DQ _d	Data Inputs/Outputs
DQP _a -Pd	Output Power Supply
V _{DD}	Power Supply
V _{DDQ}	Output Power Supply
V _{SS}	Ground

119 BGA PACKAGE PIN CONFIGURATION

256Kx18 (TOP VIEW)

	1	2	3	4	5	6	7
A	V _{DDQ}	A	A	$\overline{\text{ADSP}}$	A	A	V _{DDQ}
B	NC	CE2	A	$\overline{\text{ADSC}}$	A	$\overline{\text{CE2}}$	NC
C	NC	A	A	V _{DD}	A	A	NC
D	DQb	NC	V _{SS}	NC	V _{SS}	DQP _a	NC
E	NC	DQb	V _{SS}	$\overline{\text{CE}}$	V _{SS}	NC	DQ _a
F	V _{DDQ}	NC	V _{SS}	$\overline{\text{OE}}$	V _{SS}	DQ _a	V _{DDQ}
G	NC	DQb	$\overline{\text{BWb}}$	$\overline{\text{ADV}}$	V _{SS}	NC	DQ _a
H	DQb	NC	V _{SS}	$\overline{\text{GW}}$	V _{SS}	DQ _a	NC
J	V _{DDQ}	V _{DD}	NC	V _{DD}	NC	V _{DD}	V _{DDQ}
K	NC	DQb	V _{SS}	CLK	V _{SS}	NC	DQ _a
L	DQb	NC	V _{SS}	NC	$\overline{\text{BWa}}$	DQ _a	NC
M	V _{DDQ}	DQb	V _{SS}	$\overline{\text{BWE}}$	V _{SS}	NC	V _{DDQ}
N	DQb	NC	V _{SS}	A ₁ *	V _{SS}	DQ _a	NC
P	NC	DQP _b	V _{SS}	A ₀ *	V _{SS}	NC	DQ _a
R	NC	A	MODE	V _{DD}	NC	A	NC
T	NC	A	A	NC	A	A	ZZ
U	V _{DDQ}	NC	NC	NC	NC	NC	V _{DDQ}

Note: * A₀ and A₁ are the two least significant bits (LSB) of the address field and set the internal burst counter if burst is desired.

PIN DESCRIPTIONS

Symbol	Pin Name
A	Address Inputs
A0, A1	Synchronous Burst Address Inputs
$\overline{\text{ADV}}$	Synchronous Burst Address Advance
$\overline{\text{ADSP}}$	Address Status Processor
$\overline{\text{ADSC}}$	Address Status Controller
$\overline{\text{GW}}$	Global Write Enable
CLK	Synchronous Clock
$\overline{\text{CE}}$, CE2, $\overline{\text{CE2}}$	Synchronous Chip Select
$\overline{\text{BW}}_x$ (x=a,b)	Synchronous Byte Write Controls
$\overline{\text{BWE}}$	Byte Write Enable

Symbol	Pin Name
$\overline{\text{OE}}$	Output Enable
ZZ	Power Sleep Mode
MODE	Burst Sequence Selection
NC	No Connect
DQ _a -DQ _b	Data Inputs/Outputs
DQP _a -P _b	Output Power Supply
V _{DD}	Power Supply
V _{DDQ}	Output Power Supply
V _{SS}	Ground

165 PBGA PACKAGE PIN CONFIGURATION

128K x 36 (TOP VIEW)

	1	2	3	4	5	6	7	8	9	10	11
A	NC	A	\overline{CE}	\overline{BWC}	\overline{BWb}	$\overline{CE2}$	\overline{BWE}	\overline{ADSC}	\overline{ADV}	A	NC
B	NC	A	CE2	\overline{BWd}	\overline{BWa}	CLK	\overline{GW}	\overline{OE}	\overline{ADSP}	A	NC
C	DQPc	NC	V _{DDQ}	V _{SS}	V _{SS}	V _{SS}	V _{SS}	V _{SS}	V _{DDQ}	NC	DQPb
D	DQc	DQc	V _{DDQ}	V _{DD}	V _{SS}	V _{SS}	V _{SS}	V _{DD}	V _{DDQ}	DQb	DQb
E	DQc	DQc	V _{DDQ}	V _{DD}	V _{SS}	V _{SS}	V _{SS}	V _{DD}	V _{DDQ}	DQb	DQb
F	DQc	DQc	V _{DDQ}	V _{DD}	V _{SS}	V _{SS}	V _{SS}	V _{DD}	V _{DDQ}	DQb	DQb
G	DQc	DQc	V _{DDQ}	V _{DD}	V _{SS}	V _{SS}	V _{SS}	V _{DD}	V _{DDQ}	DQb	DQb
H	NC	NC	NC	V _{DD}	V _{SS}	V _{SS}	V _{SS}	V _{DD}	NC	NC	ZZ
J	DQd	DQd	V _{DDQ}	V _{DD}	V _{SS}	V _{SS}	V _{SS}	V _{DD}	V _{DDQ}	DQa	DQa
K	DQd	DQd	V _{DDQ}	V _{DD}	V _{SS}	V _{SS}	V _{SS}	V _{DD}	V _{DDQ}	DQa	DQa
L	DQd	DQd	V _{DDQ}	V _{DD}	V _{SS}	V _{SS}	V _{SS}	V _{DD}	V _{DDQ}	DQa	DQa
M	DQd	DQd	V _{DDQ}	V _{DD}	V _{SS}	V _{SS}	V _{SS}	V _{DD}	V _{DDQ}	DQa	DQa
N	DQPd	NC	V _{DDQ}	V _{SS}	NC	NC	NC	V _{SS}	V _{DDQ}	NC	DQPd
P	NC	NC	A	A	NC	A1*	NC	A	A	A	NC
R	MODE	NC	A	A	NC	A0*	NC	A	A	A	A

Note: * A0 and A1 are the two least significant bits (LSB) of the address field and set the internal burst counter if burst is desired.

PIN DESCRIPTIONS

Symbol	Pin Name
A	Address Inputs
A0, A1	Synchronous Burst Address Inputs
\overline{ADV}	Synchronous Burst Address Advance
\overline{ADSP}	Address Status Processor
\overline{ADSC}	Address Status Controller
\overline{GW}	Global Write Enable
CLK	Synchronous Clock
\overline{CE} , $\overline{CE2}$, CE2	Synchronous Chip Select
\overline{BWx} (x=a,b,c,d)	Synchronous Byte Write Controls

Symbol	Pin Name
\overline{BWE}	Byte Write Enable
\overline{OE}	Output Enable
ZZ	Power Sleep Mode
MODE	Burst Sequence Selection
NC	No Connect
DQx	Data Inputs/Outputs
DQPx	Data Inputs/Outputs
V _{DD}	3.3V/2.5V Power Supply
V _{DDQ}	Isolated Output Power Supply 3.3V/2.5V
V _{SS}	Ground

165 PBGA PACKAGE PIN CONFIGURATION

256K x 18 (TOP VIEW)

	1	2	3	4	5	6	7	8	9	10	11
A	NC	A	\overline{CE}	\overline{BWB}	NC	$\overline{CE2}$	\overline{BWE}	\overline{ADSC}	\overline{ADV}	A	A
B	NC	A	CE2	NC	\overline{BWA}	CLK	\overline{GW}	\overline{OE}	\overline{ADSP}	A	NC
C	NC	NC	V _{DDQ}	V _{SS}	V _{SS}	V _{SS}	V _{SS}	V _{SS}	V _{DDQ}	NC	DQP _a
D	NC	DQ _b	V _{DDQ}	V _{DD}	V _{SS}	V _{SS}	V _{SS}	V _{DD}	V _{DDQ}	NC	DQ _a
E	NC	DQ _b	V _{DDQ}	V _{DD}	V _{SS}	V _{SS}	V _{SS}	V _{DD}	V _{DDQ}	NC	DQ _a
F	NC	DQ _b	V _{DDQ}	V _{DD}	V _{SS}	V _{SS}	V _{SS}	V _{DD}	V _{DDQ}	NC	DQ _a
G	NC	DQ _b	V _{DDQ}	V _{DD}	V _{SS}	V _{SS}	V _{SS}	V _{DD}	V _{DDQ}	NC	DQ _a
H	NC	NC	NC	V _{DD}	V _{SS}	V _{SS}	V _{SS}	V _{DD}	NC	NC	ZZ
J	DQ _b	NC	V _{DDQ}	V _{DD}	V _{SS}	V _{SS}	V _{SS}	V _{DD}	V _{DDQ}	DQ _a	NC
K	DQ _b	NC	V _{DDQ}	V _{DD}	V _{SS}	V _{SS}	V _{SS}	V _{DD}	V _{DDQ}	DQ _a	NC
L	DQ _b	NC	V _{DDQ}	V _{DD}	V _{SS}	V _{SS}	V _{SS}	V _{DD}	V _{DDQ}	DQ _a	NC
M	DQ _b	NC	V _{DDQ}	V _{DD}	V _{SS}	V _{SS}	V _{SS}	V _{DD}	V _{DDQ}	DQ _a	NC
N	DQP _b	NC	V _{DDQ}	V _{SS}	NC	NC	NC	V _{SS}	V _{DDQ}	NC	NC
P	NC	NC	A	A	NC	A1*	NC	A	A	A	NC
R	MODE	NC	A	A	NC	A0*	NC	A	A	A	A

Note: * A₀ and A₁ are the two least significant bits (LSB) of the address field and set the internal burst counter if burst is desired.

PIN DESCRIPTIONS

Symbol	Pin Name
A	Address Inputs
A ₀ , A ₁	Synchronous Burst Address Inputs
\overline{ADV}	Synchronous Burst Address Advance
\overline{ADSP}	Address Status Processor
\overline{ADSC}	Address Status Controller
\overline{GW}	Global Write Enable
CLK	Synchronous Clock
\overline{CE} , $\overline{CE2}$, CE2	Synchronous Chip Select
\overline{BWx} (x=a,b)	Synchronous Byte Write Controls

Symbol	Pin Name
\overline{BWE}	Byte Write Enable
\overline{OE}	Output Enable
ZZ	Power Sleep Mode
MODE	Burst Sequence Selection
NC	No Connect
DQ _x	Data Inputs/Outputs
DQP _x	Data Inputs/Outputs
V _{DD}	3.3V/2.5V Power Supply
V _{DDQ}	Isolated Output Power Supply 3.3V/2.5V
V _{SS}	Ground

PIN CONFIGURATION

100-PIN TQFP (128K x 36)

100-PIN TQFP (128K x 32)

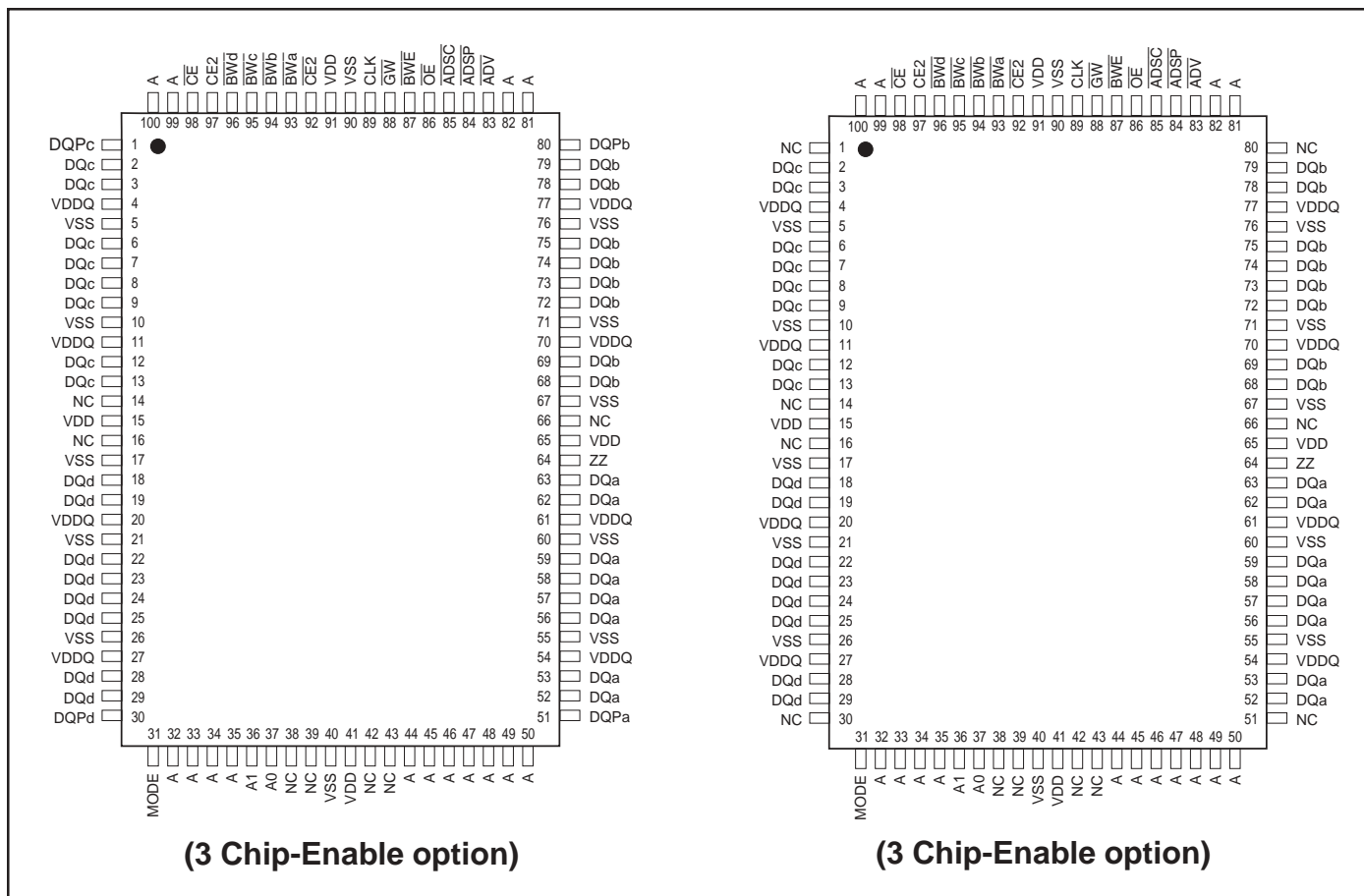

PIN DESCRIPTIONS

A0, A1	Synchronous Address Inputs. These pins must be tied to the two LSBs of the address bus.
A	Synchronous Address Inputs
$\overline{\text{ADSC}}$	Synchronous Controller Address Status
$\overline{\text{ADSP}}$	Synchronous Processor Address Status
$\overline{\text{ADV}}$	Synchronous Burst Address Advance
$\overline{\text{BwA}}-\overline{\text{BwD}}$	Synchronous Byte Write Enable
$\overline{\text{BWE}}$	Synchronous Byte Write Enable
$\overline{\text{CE}}$, $\overline{\text{CE2}}$, CE2	Synchronous Chip Enable
CLK	Synchronous Clock

DQa-DQd	Synchronous Data Input/Output
DQPa-DQPd	Parity Data Input/Output
$\overline{\text{GW}}$	Synchronous Global Write Enable
MODE	Burst Sequence Mode Selection
$\overline{\text{OE}}$	Output Enable
VDD	3.3V/2.5V Power Supply
VDDQ	Isolated Output Buffer Supply: 3.3V/2.5V
VSS	Ground
ZZ	Snooze Enable

PIN CONFIGURATION

100-PIN TQFP (256K x 18)

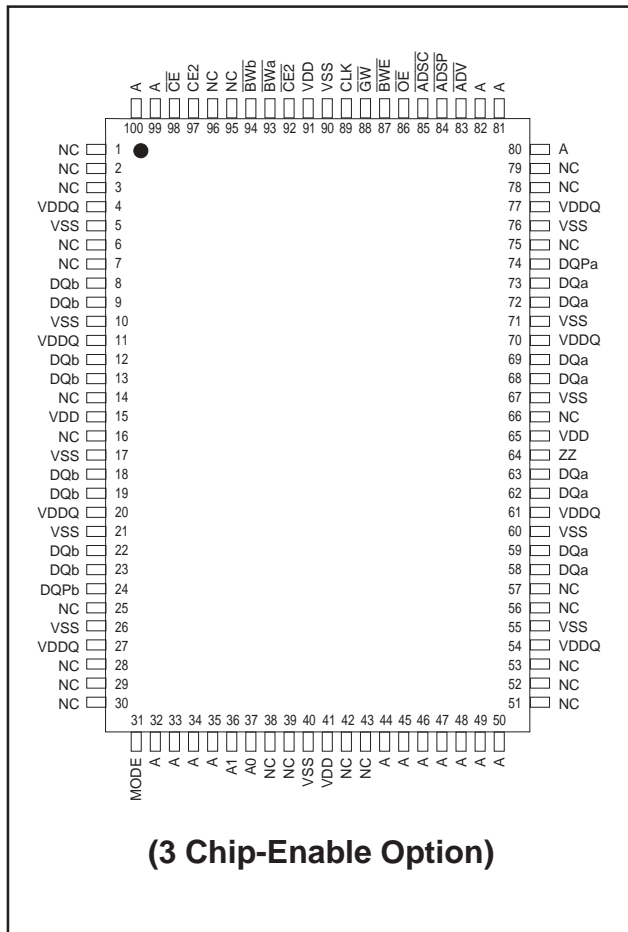

PIN DESCRIPTIONS

A0, A1	Synchronous Address Inputs. These pins must tied to the two LSBs of the address bus.	DQPa-DQPb	Parity Data I/O; DQPa is parity for DQa1-8; DQPb is parity for DQb1-8
A	Synchronous Address Inputs	\overline{GW}	Synchronous Global Write Enable
\overline{ADSC}	Synchronous Controller Address Status	MODE	Burst Sequence Mode Selection
\overline{ADSP}	Synchronous Processor Address Status	\overline{OE}	Output Enable
\overline{ADV}	Synchronous Burst Address Advance	VDD	3.3V/2.5V Power Supply
$\overline{BWA-BWb}$	Synchronous Byte Write Enable	VDDQ	Isolated Output Buffer Supply: 3.3V/2.5V
\overline{BWE}	Synchronous Byte Write Enable	VSS	Ground
$\overline{CE}, CE2, \overline{CE2}$	Synchronous Chip Enable	ZZ	Snooze Enable
CLK	Synchronous Clock		
DQa-DQb	Synchronous Data Input/Output		

TRUTH TABLE⁽¹⁻⁸⁾

OPERATION	ADDRESS	\overline{CE}	$\overline{CE2}$	CE2	ZZ	\overline{ADSP}	\overline{ADSC}	\overline{ADV}	WRITE	\overline{OE}	CLK	DQ
Deselect Cycle, Power-Down	None	H	X	X	L	X	L	X	X	X	L-H	High-Z
Deselect Cycle, Power-Down	None	L	X	L	L	L	X	X	X	X	L-H	High-Z
Deselect Cycle, Power-Down	None	L	H	X	L	L	X	X	X	X	L-H	High-Z
Deselect Cycle, Power-Down	None	L	X	L	L	H	L	X	X	X	L-H	High-Z
Deselect Cycle, Power-Down	None	L	H	X	L	H	L	X	X	X	L-H	High-Z
Snooze Mode, Power-Down	None	X	X	X	H	X	X	X	X	X	X	High-Z
Read Cycle, Begin Burst	External	L	L	H	L	L	X	X	X	L	L-H	Q
Read Cycle, Begin Burst	External	L	L	H	L	L	X	X	X	H	L-H	High-Z
Write Cycle, Begin Burst	External	L	L	H	L	H	L	X	L	X	L-H	D
Read Cycle, Begin Burst	External	L	L	H	L	H	L	X	H	L	L-H	Q
Read Cycle, Begin Burst	External	L	L	H	L	H	L	X	H	H	L-H	High-Z
Read Cycle, Continue Burst	Next	X	X	X	L	H	H	L	H	L	L-H	Q
Read Cycle, Continue Burst	Next	X	X	X	L	H	H	L	H	H	L-H	High-Z
Read Cycle, Continue Burst	Next	H	X	X	L	X	H	L	H	L	L-H	Q
Read Cycle, Continue Burst	Next	H	X	X	L	X	H	L	H	H	L-H	High-Z
Write Cycle, Continue Burst	Next	X	X	X	L	H	H	L	L	X	L-H	D
Write Cycle, Continue Burst	Next	H	X	X	L	X	H	L	L	X	L-H	D
Read Cycle, Suspend Burst	Current	X	X	X	L	H	H	H	H	L	L-H	Q
Read Cycle, Suspend Burst	Current	X	X	X	L	H	H	H	H	H	L-H	High-Z
Read Cycle, Suspend Burst	Current	H	X	X	L	X	H	H	H	L	L-H	Q
Read Cycle, Suspend Burst	Current	H	X	X	L	X	H	H	H	H	L-H	High-Z
Write Cycle, Suspend Burst	Current	X	X	X	L	H	H	H	L	X	L-H	D
Write Cycle, Suspend Burst	Current	H	X	X	L	X	H	H	L	X	L-H	D

NOTE:

1. X means "Don't Care." H means logic HIGH. L means logic LOW.
2. For **WRITE**, L means one or more byte write enable signals ($\overline{BWA-d}$) and \overline{BWE} are LOW or \overline{GW} is LOW. **WRITE** = H for all \overline{BWx} , \overline{BWE} , \overline{GW} HIGH.
3. \overline{BWA} enables WRITES to DQa's and DQPa. \overline{BWB} enables WRITES to DQb's and DQPb. \overline{BWC} enables WRITES to DQc's and DQPC. \overline{BWD} enables WRITES to DQd's and DQPd. DQPa and DQPb are available on the x18 version. DQPa-DQPd are available on the x36 version.
4. All inputs except \overline{OE} and ZZ must meet setup and hold times around the rising edge (LOW to HIGH) of CLK.
5. Wait states are inserted by suspending burst.
6. For a WRITE operation following a READ operation, \overline{OE} must be HIGH before the input data setup time and held HIGH during the input data hold time.
7. This device contains circuitry that will ensure the outputs will be in High-Z during power-up.
8. \overline{ADSP} LOW always initiates an internal READ at the L-H edge of CLK. A WRITE is performed by setting one or more byte write enable signals and \overline{BWE} LOW or \overline{GW} LOW for the subsequent L-H edge of CLK. See WRITE timing diagram for clarification.

PARTIAL TRUTH TABLE

Function	\overline{GW}	\overline{BWE}	\overline{BWA}	\overline{BWB}	\overline{BWC}	\overline{BWD}
Read	H	H	X	X	X	X
Read	H	L	H	H	H	H
Write Byte 1	H	L	L	H	H	H
Write All Bytes	H	L	L	L	L	L
Write All Bytes	L	X	X	X	X	X

INTERLEAVED BURST ADDRESS TABLE (MODE = V_{DD} or No Connect)

External Address A1 A0	1st Burst Address A1 A0	2nd Burst Address A1 A0	3rd Burst Address A1 A0
00	01	10	11
01	00	11	10
10	11	00	01
11	10	01	00

LINEAR BURST ADDRESS TABLE (MODE = V_{SS})

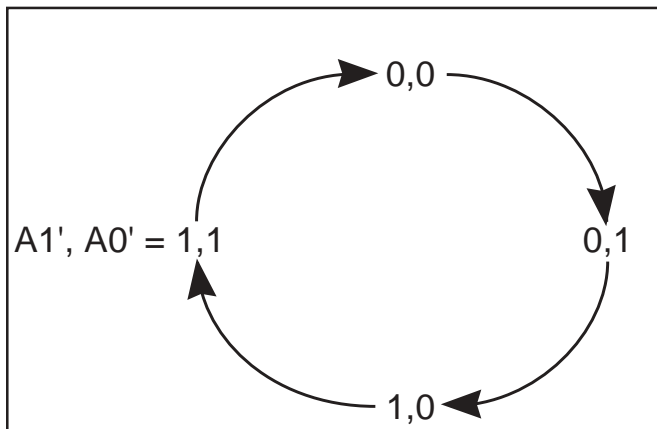

ABSOLUTE MAXIMUM RATINGS⁽¹⁾

Symbol	Parameter	Value	Unit
T _{STG}	Storage Temperature	-55 to +150	°C
P _D	Power Dissipation	1.6	W
I _{OUT}	Output Current (per I/O)	100	mA
V _{IN} , V _{OUT}	Voltage Relative to V _{SS} for I/O Pins	-0.5 to V _{DDQ} + 0.5	V
V _{IN}	Voltage Relative to V _{SS} for for Address and Control Inputs	-0.5 to V _{DD} + 0.5	V
V _{DD}	Voltage on V _{DD} Supply Relative to V _{SS}	-0.5 to 4.6	V

Notes:

1. Stress greater than those listed under ABSOLUTE MAXIMUM RATINGS may cause permanent damage to the device. This is a stress rating only and functional operation of the device at these or any other conditions above those indicated in the operational sections of this specification is not implied. Exposure to absolute maximum rating conditions for extended periods may affect reliability.
2. This device contains circuitry to protect the inputs against damage due to high static voltages or electric fields; however, precautions may be taken to avoid application of any voltage higher than maximum rated voltages to this high-impedance circuit.
3. This device contains circuitry that will ensure the output devices are in High-Z at power up.

OPERATING RANGE (IS61/64LFxxxxx)

Range	Ambient Temperature	V _{DD}	V _{DDQ}
Commercial	0°C to +70°C	3.3V ± 5%	3.3V/2.5V ± 5%
Industrial	-40°C to +85°C	3.3V ± 5%	3.3V/2.5V ± 5%
Automotive	-40°C to +125°C	3.3V ± 5%	3.3V/2.5V ± 5%

OPERATING RANGE (IS61/64VFxxxxx)

Range	Ambient Temperature	V _{DD}	V _{DDQ}
Commercial	0°C to +70°C	2.5V -5% +10%	2.5V -5% +10%
Industrial	-40°C to +85°C	2.5V -5% +10%	2.5V -5% +10%
Automotive	-40°C to +125°C	2.5V -5% +10%	2.5V -5% +10%

DC ELECTRICAL CHARACTERISTICS (Over Operating Range)

Symbol	Parameter	Test Conditions	3.3V		2.5V		Unit
			Min.	Max.	Min.	Max.	
V _{OH}	Output HIGH Voltage	I _{OH} = -4.0 mA (3.3V) I _{OH} = -1.0 mA (2.5V)	2.4	—	2.0	—	V
V _{OL}	Output LOW Voltage	I _{OL} = 8.0 mA (3.3V) I _{OL} = 1.0 mA (2.5V)	—	0.4	—	0.4	V
V _{IH}	Input HIGH Voltage		2.0	V _{DD} + 0.3	1.7	V _{DD} + 0.3	V
V _{IL}	Input LOW Voltage		-0.3	0.8	-0.3	0.7	V
I _{LI}	Input Leakage Current	V _{SS} ≤ V _{IN} ≤ V _{DD} ⁽¹⁾	-5	5	-5	5	μA
I _{LO}	Output Leakage Current	V _{SS} ≤ V _{OUT} ≤ V _{DDQ} , $\overline{OE} = V_{IH}$	-5	5	-5	5	μA

POWER SUPPLY CHARACTERISTICS⁽¹⁾ (Over Operating Range)

Symbol	Parameter	Test Conditions	Temp. range	6.5 MAX		7.5 MAX		Unit
				x18	x32/x36	x18	x32/x36	
I _{CC}	AC Operating Supply Current	Device Selected, $\overline{OE} = V_{IH}$, $ZZ \leq V_{IL}$, All Inputs $\leq 0.2V$ or $\geq V_{DD} - 0.2V$, Cycle Time $\geq t_{kc}$ min.	Com.	175	175	155	155	mA
			Ind.	180	180	160	160	
			AUTO.	190	190	175	175	
			typ. ⁽²⁾	120		110		
I _{SB}	Standby Current TTL Input	Device Deselected, $V_{DD} = \text{Max.}$, All Inputs $\leq V_{IL}$ or $\geq V_{IH}$, $ZZ \leq V_{IL}$, $f = \text{Max.}$	Com.	90	90	90	90	mA
			Ind.	100	100	100	100	
			Auto.	120	120	120	120	
			typ.					
I _{SB1}	Standby Current CMOS Input	Device Deselected, $V_{DD} = \text{Max.}$, $V_{IN} \leq V_{SS} + 0.2V$ or $\geq V_{DD} - 0.2V$ $f = 0$	Com.	70	70	70	70	mA
			Ind.	75	75	75	75	
			Auto.	90	90	90	90	
			typ.	40		40		
I _{SB2}	Sleep Mode	$ZZ > V_{IH}$	Com.	30	30	30	30	mA
			Ind.	35	35	35	35	
			Auto.	45	45	45	45	
			typ.	25		25		

Note:

1. MODE pin has an internal pullup and should be tied to V_{DD} or V_{SS} . It exhibits $\pm 100 \mu A$ maximum leakage current when tied to $\leq V_{SS} + 0.2V$ or $\geq V_{DD} - 0.2V$.
2. Typical values are measured at $V_{DD} = 3.3V$, $T_A = 25^\circ C$ and not 100% tested.

CAPACITANCE^(1,2)

Symbol	Parameter	Conditions	Max.	Unit
C _{IN}	Input Capacitance	$V_{IN} = 0V$	6	pF
C _{OUT}	Input/Output Capacitance	$V_{OUT} = 0V$	8	pF

Notes:

1. Tested initially and after any design or process changes that may affect these parameters.
2. Test conditions: $T_A = 25^\circ C$, $f = 1 \text{ MHz}$, $V_{DD} = 3.3V$.

3.3V I/O AC TEST CONDITIONS

Parameter	Unit
Input Pulse Level	0V to 3.0V
Input Rise and Fall Times	1.5 ns
Input and Output Timing and Reference Level	1.5V
Output Load	See Figures 1 and 2

AC TEST LOADS

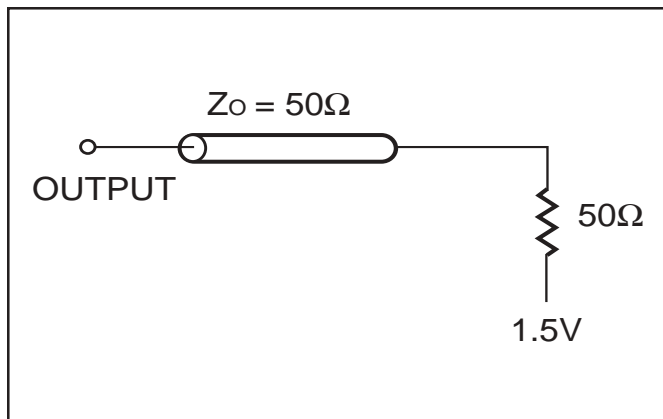

Figure 1

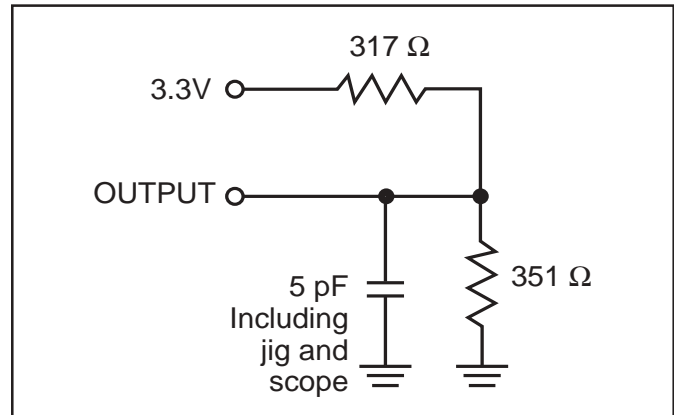

Figure 2

2.5V I/O AC TEST CONDITIONS

Parameter	Unit
Input Pulse Level	0V to 2.5V
Input Rise and Fall Times	1.5 ns
Input and Output Timing and Reference Level	1.25V
Output Load	See Figures 3 and 4

2.5V I/O OUTPUT LOAD EQUIVALENT

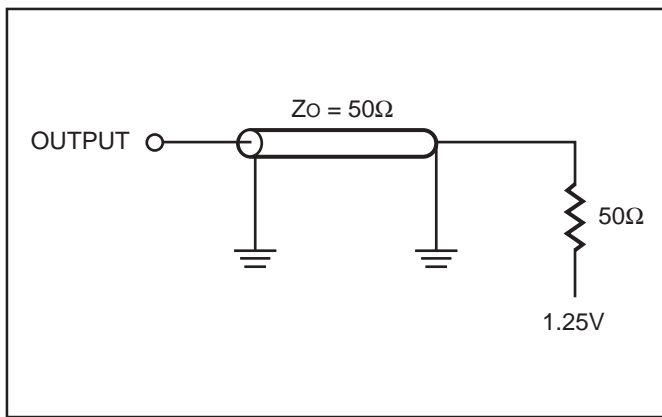

Figure 3

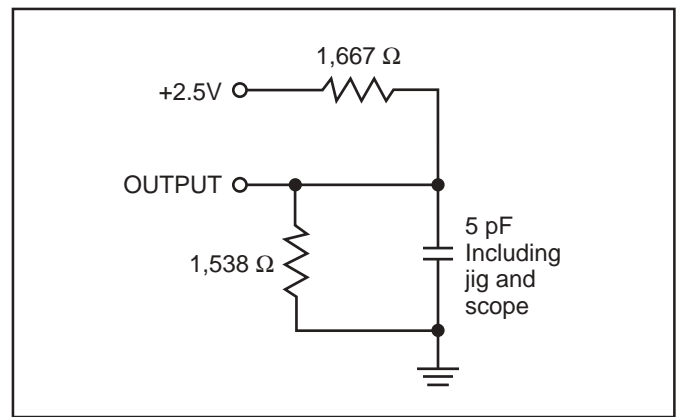

Figure 4

READ/WRITE CYCLE SWITCHING CHARACTERISTICS⁽¹⁾ (Over Operating Range)

Symbol	Parameter	6.5		7.5		Unit
		Min.	Max.	Min.	Max.	
fmax	Clock Frequency	—	133	—	117	MHz
tkc	Cycle Time	7.5	—	8.5	—	ns
tkh	Clock High Time	2.2	—	2.5	—	ns
tkl	Clock Low Time	2.2	—	2.5	—	ns
tkq	Clock Access Time	—	6.5	—	7.5	ns
tkqx ⁽²⁾	Clock High to Output Invalid	2.5	—	2.5	—	ns
tkqlz ^(2,3)	Clock High to Output Low-Z	2.5	—	2.5	—	ns
tkqhz ^(2,3)	Clock High to Output High-Z	—	3.8	—	4.0	ns
toeq	Output Enable to Output Valid	—	3.2	—	3.4	ns
toeqx ⁽²⁾	Output Enable to Output Invalid	2.5	—	2.5	—	ns
toelz ^(2,3)	Output Enable to Output Low-Z	0	—	0	—	ns
toehz ^(2,3)	Output Disable to Output High-Z	—	3.5	—	3.5	ns
tas	Address Setup Time	1.5	—	1.5	—	ns
tws	Read/Write Setup Time	1.5	—	1.5	—	ns
tcas	Chip Enable Setup Time	1.5	—	1.5	—	ns
tavs	Address Advance Setup Time	1.5	—	1.5	—	ns
tds	Data Setup Time	1.5	—	1.5	—	ns
tah	Address Hold Time	0.5	—	0.5	—	ns
twh	Write Hold Time	0.5	—	0.5	—	ns
tceh	Chip Enable Hold Time	0.5	—	0.5	—	ns
tavh	Address Advance Hold Time	0.5	—	0.5	—	ns
tdh	Data Hold Time	0.5	—	0.5	—	ns
tpds	ZZ High to Power Down	—	2	—	2	cyc
tpus	ZZ Low to Power Down	—	2	—	2	cyc

Notes:

1. Configuration signal MODE is static and must not change during normal operation.
2. Guaranteed but not 100% tested. This parameter is periodically sampled.
3. Tested with load in Figure 2.

READ/WRITE CYCLE TIMING

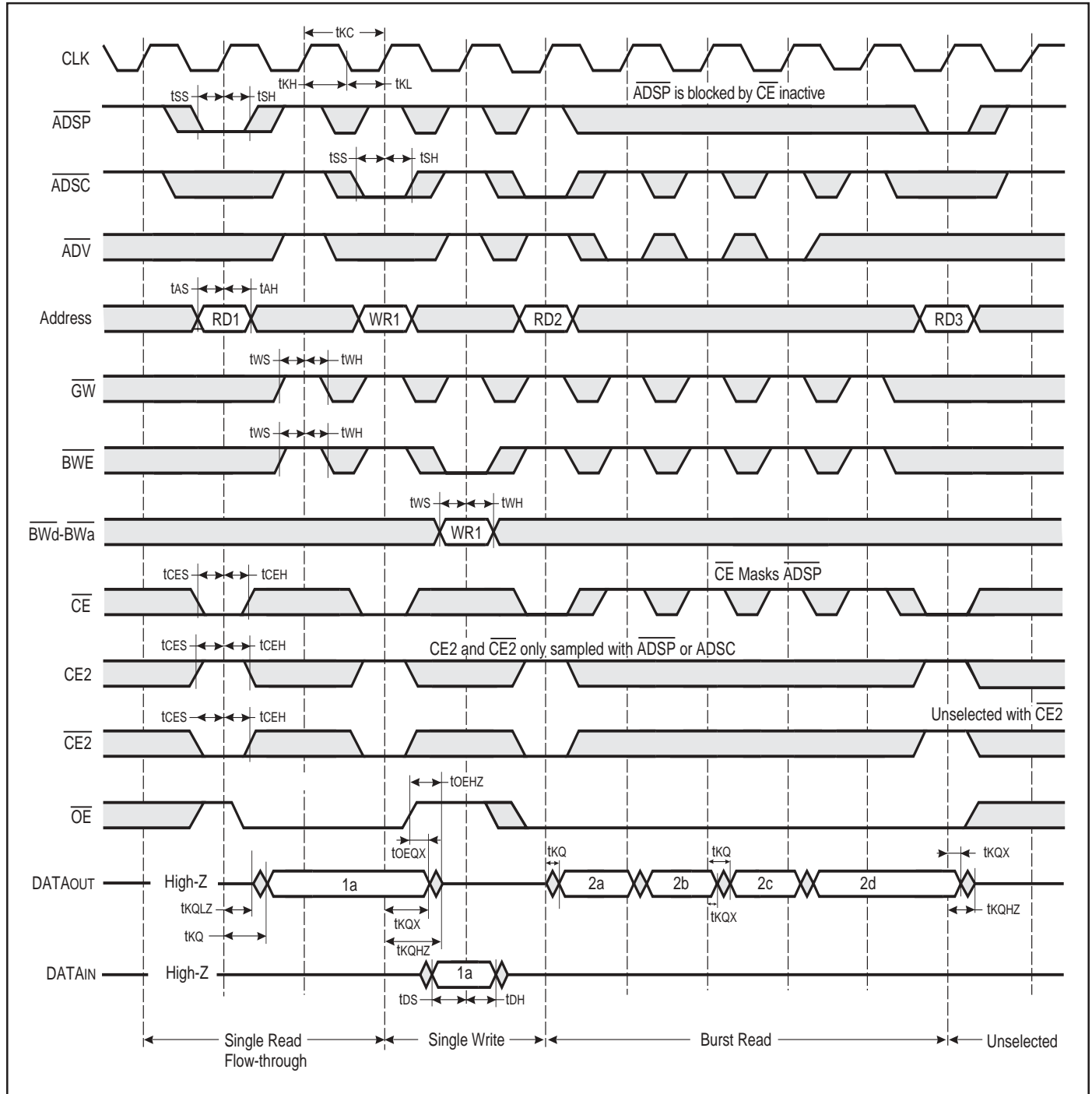

WRITE CYCLE TIMING

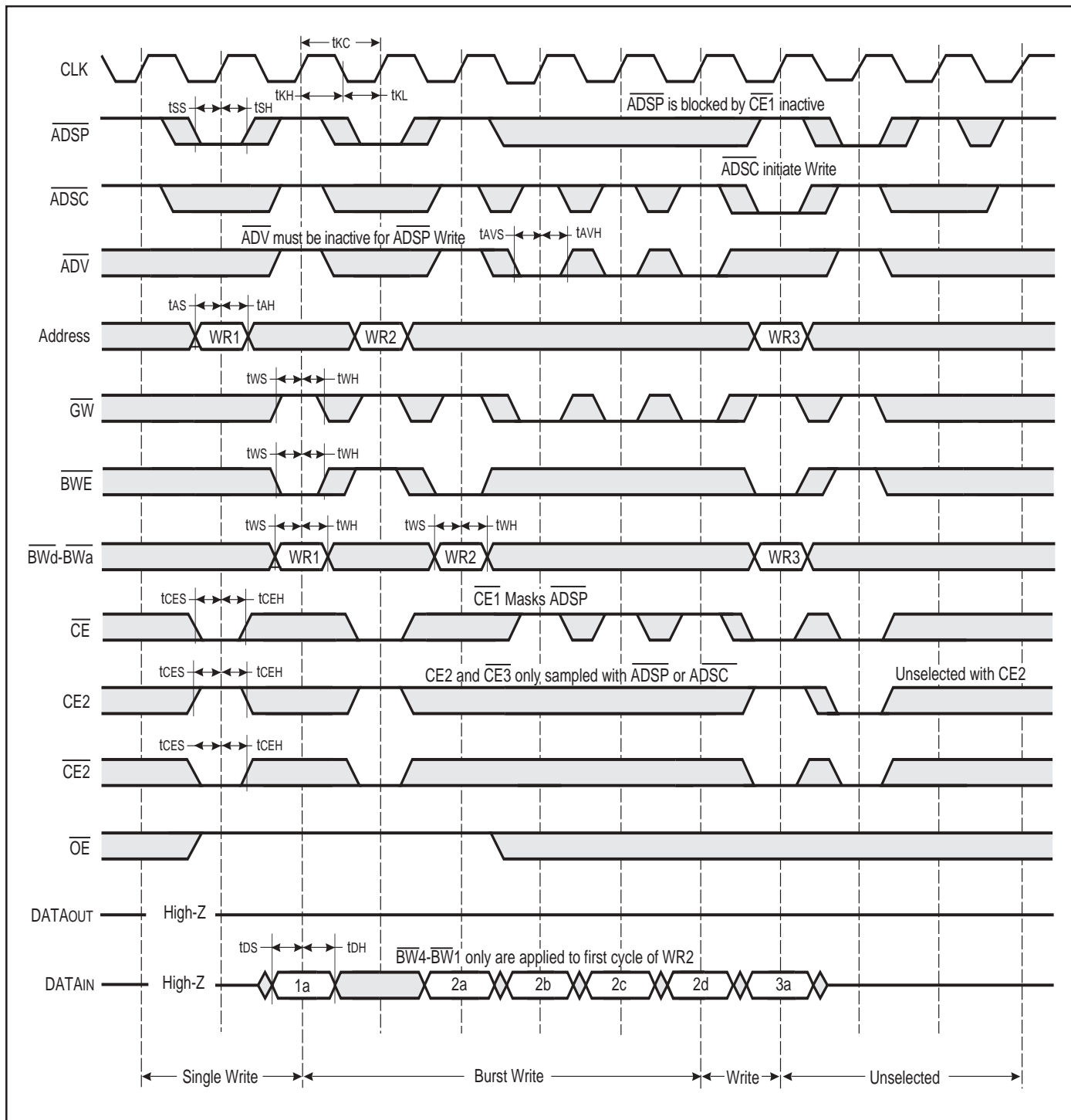

SNOOZE MODE ELECTRICAL CHARACTERISTICS

Symbol	Parameter	Conditions	Min.	Max.	Unit
ISB2	Current during SNOOZE MODE	ZZ ≥ Vih	—	60	mA
tPDS	ZZ active to input ignored		—	2	cycle
tPUS	ZZ inactive to input sampled		2	—	cycle
tZZI	ZZ active to SNOOZE current		—	2	cycle
tRZZI	ZZ inactive to exit SNOOZE current		0	—	ns

SNOOZE MODE TIMING

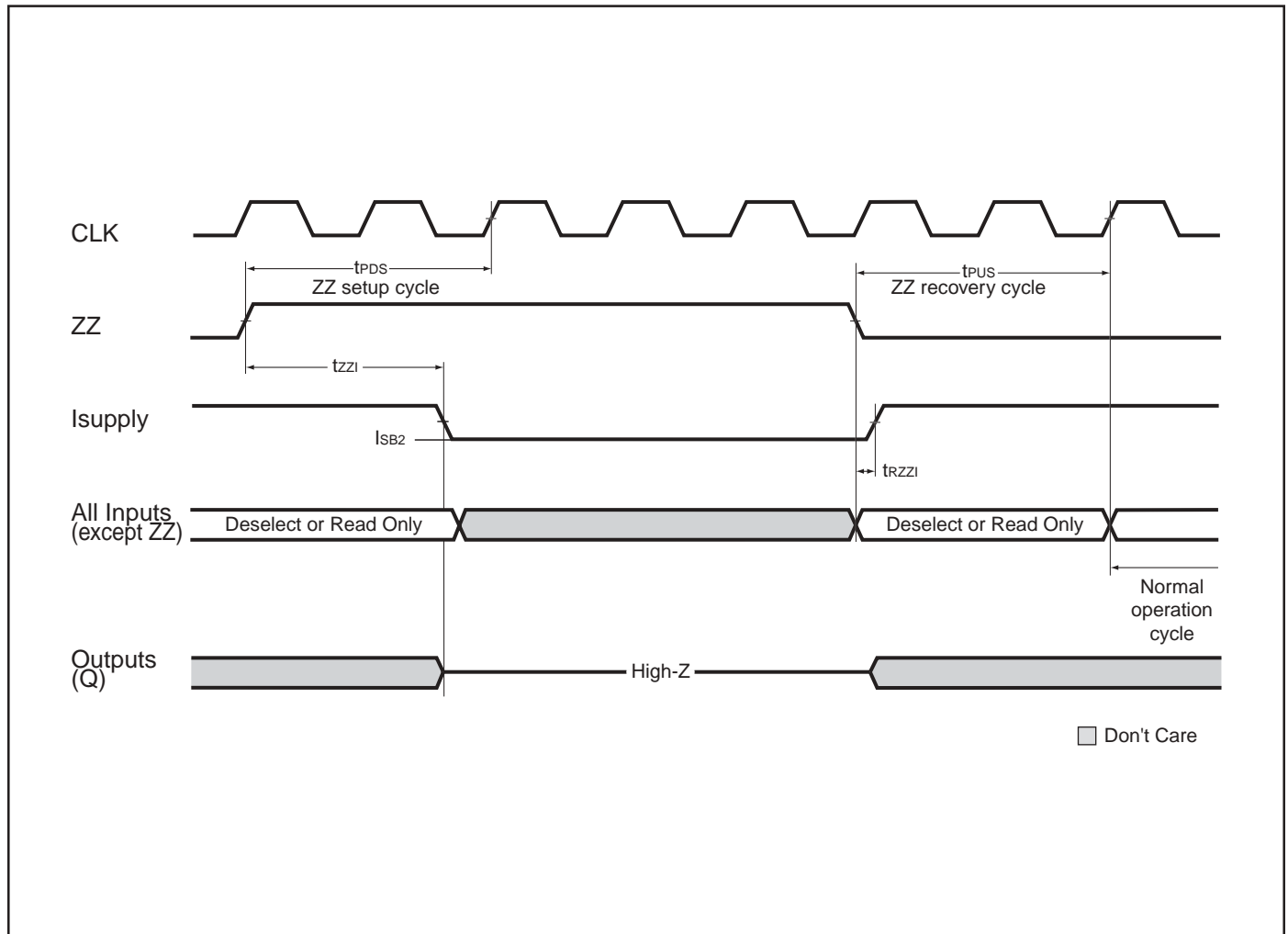

IS61(64)LF12832A, IS61(64)LF12836A, IS61(64)LF25618A
 IS64VF12832A, IS61(64)VF12836A, IS61(64)VF25618A



ORDERING INFORMATION (V_{DD} = 3.3V/V_{DDQ} = 2.5V/3.3V)
Commercial Range: 0°C to +70°C

Configuration	Access Time	Order Part Number	Package
128Kx32	6.5	IS61LF12832A-6.5TQ	100 TQFP
		IS61LF12832A-6.5B2	119 PBGA
		IS61LF12832A-6.5B3	165 PBGA
128Kx32	7.5	IS61LF12832A-7.5TQ	100 TQFP
		IS61LF12832A-7.5B2	119 PBGA
		IS61LF12832A-7.5B3	165 PBGA
128Kx36	6.5	IS61LF12836A-6.5TQ	100 TQFP
		IS61LF12836A-6.5B2	119 PBGA
		IS61LF12836A-6.5B3	165 PBGA
128Kx36	7.5	IS61LF12836A-7.5TQ	100 TQFP
		IS61LF12836A-7.5B2	119 PBGA
		IS61LF12836A-7.5B3	165 PBGA
256Kx18	6.5	IS61LF25618A-6.5TQ	100 TQFP
		IS61LF25618A-6.5B2	119 PBGA
		IS61LF25618A-6.5B3	165 PBGA
256Kx18	7.5	IS61LF25618A-7.5TQ	100 TQFP
		IS61LF25618A-7.5B2	119 PBGA
		IS61LF25618A-7.5B3	165 PBGA

**IS61(64)LF12832A, IS61(64)LF12836A, IS61(64)LF25618A
IS64VF12832A, IS61(64)VF12836A, IS61(64)VF25618A**



ORDERING INFORMATION ($V_{DD} = 3.3V/V_{DDQ} = 2.5V/3.3V$)

Industrial Range: -40°C to +85°C

Configuration	Access Time	Order Part Number	Package
128Kx32	6.5	IS61LF12832A-6.5TQI	100 TQFP
		IS61LF12832A-6.5B2I	119 PBGA
		IS61LF12832A-6.5B3I	165 PBGA
128Kx32	7.5	IS61LF12832A-7.5TQI	100 TQFP
		IS61LF12832A-7.5TQLI	100 TQFP, Lead-free
		IS61LF12832A-7.5B2I	119 PBGA
		IS61LF12832A-7.5B3I	165 PBGA
128Kx36	6.5	IS61LF12836A-6.5TQI	100 TQFP
		IS61LF12836A-6.5B2I	119 PBGA
		IS61LF12836A-6.5B3I	165 PBGA
128Kx36	7.5	IS61LF12836A-7.5TQI	100 TQFP
		IS61LF12836A-7.5TQLI	100 TQFP, Lead-free
		IS61LF12836A-7.5B2I	119 PBGA
		IS61LF12836A-7.5B3I	165 PBGA
256Kx18	6.5	IS61LF25618A-6.5TQI	100 TQFP
		IS61LF25618A-6.5B2I	119 PBGA
		IS61LF25618A-6.5B3I	165 PBGA
256Kx18	7.5	IS61LF25618A-7.5TQI	100 TQFP
		IS61LF25618A-7.5TQLI	100 TQFP, Lead-free
		IS61LF25618A-7.5B2I	119 PBGA
		IS61LF25618A-7.5B3I	165 PBGA

Automotive Range: -40°C to +125°C

Configuration	Access Time	Order Part Number	Package
128Kx32	7.5	IS64LF12832A-7.5TQA3	100 TQFP
		IS64LF12832A-7.5TQLA3	100 TQFP, Lead-free
128Kx36	7.5	IS64LF12836A-7.5TQA3	100 TQFP
256Kx18	7.5	IS64LF25618A-7.5TQA3	100 TQFP

IS61(64)LF12832A, IS61(64)LF12836A, IS61(64)LF25618A
IS64VF12832A, IS61(64)VF12836A, IS61(64)VF25618A



ORDERING INFORMATION (V_{DD} = 2.5V /V_{DDQ} = 2.5V)
Commercial Range: 0°C to +70°C

Configuration	Access Time	Order Part Number	Package
128Kx36	6.5	IS61VF12836A-6.5TQ	100 TQFP
		IS61VF12836A-6.5B2	119 PBGA
		IS61VF12836A-6.5B3	165 PBGA
128Kx36	7.5	IS61VF12836A-7.5TQ	100 TQFP
		IS61VF12836A-7.5B2	119 PBGA
		IS61VF12836A-7.5B3	165 PBGA
256Kx18	6.5	IS61VF25618A-6.5TQ	100 TQFP
		IS61VF25618A-6.5B2	119 PBGA
		IS61VF25618A-6.5B3	165 PBGA
256Kx18	7.5	IS61VF25618A-7.5TQ	100 TQFP
		IS61VF25618A-7.5B2	119 PBGA
		IS61VF25618A-7.5B3	165 PBGA

Industrial Range: -40°C to +85°C

Configuration	Access Time	Order Part Number	Package
128Kx36	6.5	IS61VF12836A-6.5TQI	100 TQFP
		IS61VF12836A-6.5B2I	119 PBGA
		IS61VF12836A-6.5B3I	165 PBGA
128Kx36	7.5	IS61VF12836A-7.5TQI	100 TQFP
		IS61VF12836A-7.5B2I	119 PBGA
		IS61VF12836A-7.5B3I	165 PBGA
256Kx18	6.5	IS61VF25618A-6.5TQI	100 TQFP
		IS61VF25618A-6.5B2I	119 PBGA
		IS61VF25618A-6.5B3I	165 PBGA
256Kx18	7.5	IS61VF25618A-7.5TQI	100 TQFP
		IS61VF25618A-7.5B2I	119 PBGA
		IS61VF25618A-7.5B3I	165 PBGA

Automotive Range: -40°C to +125°C

Configuration	Access Time	Order Part Number	Package
128Kx32	7.5	IS64VF12832A-7.5TQLA3	100 TQFP, Lead-free
128Kx36	7.5	IS64VF12836A-7.5TQA3	100 TQFP
256Kx18	7.5	IS64VF25618A-7.5TQA3	100 TQFP

PACKAGING INFORMATION



Plastic Ball Grid Array
Package Code: B (119-pin)

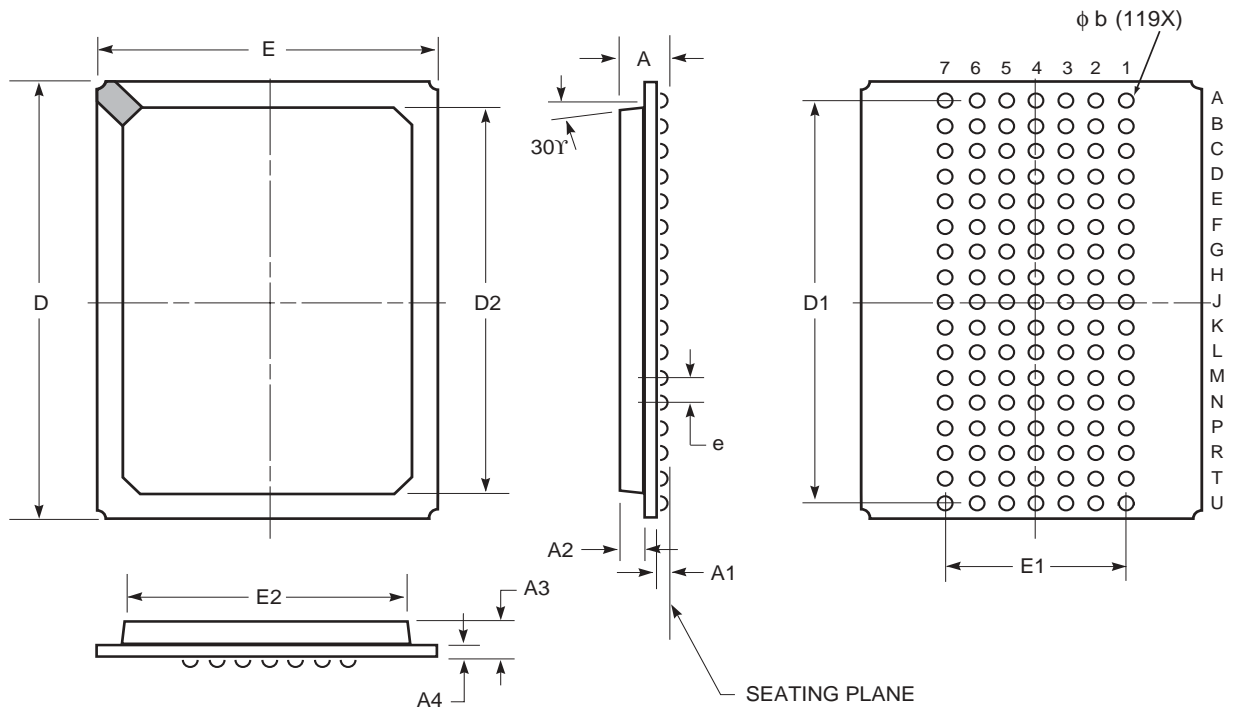

	MILLIMETERS		INCHES	
Sym.	Min.	Max.	Min.	Max.
N0.				
Leads	119			
A	—	2.41	—	0.095
A1	0.50	0.70	0.020	0.028
A2	0.80	1.00	0.032	0.039
A3	1.30	1.70	0.051	0.067
A4	0.56 BSC		0.022 BSC	
b	0.60	0.90	0.024	0.035
D	21.80	22.20	0.858	0.874
D1	20.32 BSC		0.800 BSC	
D2	19.40	19.60	0.764	0.772
E	13.80	14.20	0.543	0.559
E1	7.62 BSC		0.300 BSC	
E2	11.90	12.10	0.469	0.476
e	1.27 BSC		0.050 BSC	

Notes:

1. Controlling dimension: millimeters, unless otherwise specified.
2. BSC=Basic lead spacing between centers.
3. Dimensions D1 and E do not include mold flash protrusion and should be measured from the bottom of the package.
4. Formed leads shall be planar with respect to one another within 0.004 inches at the seating plane.

PACKAGING INFORMATION



Ball Grid Array Package Code: B (165-pin)

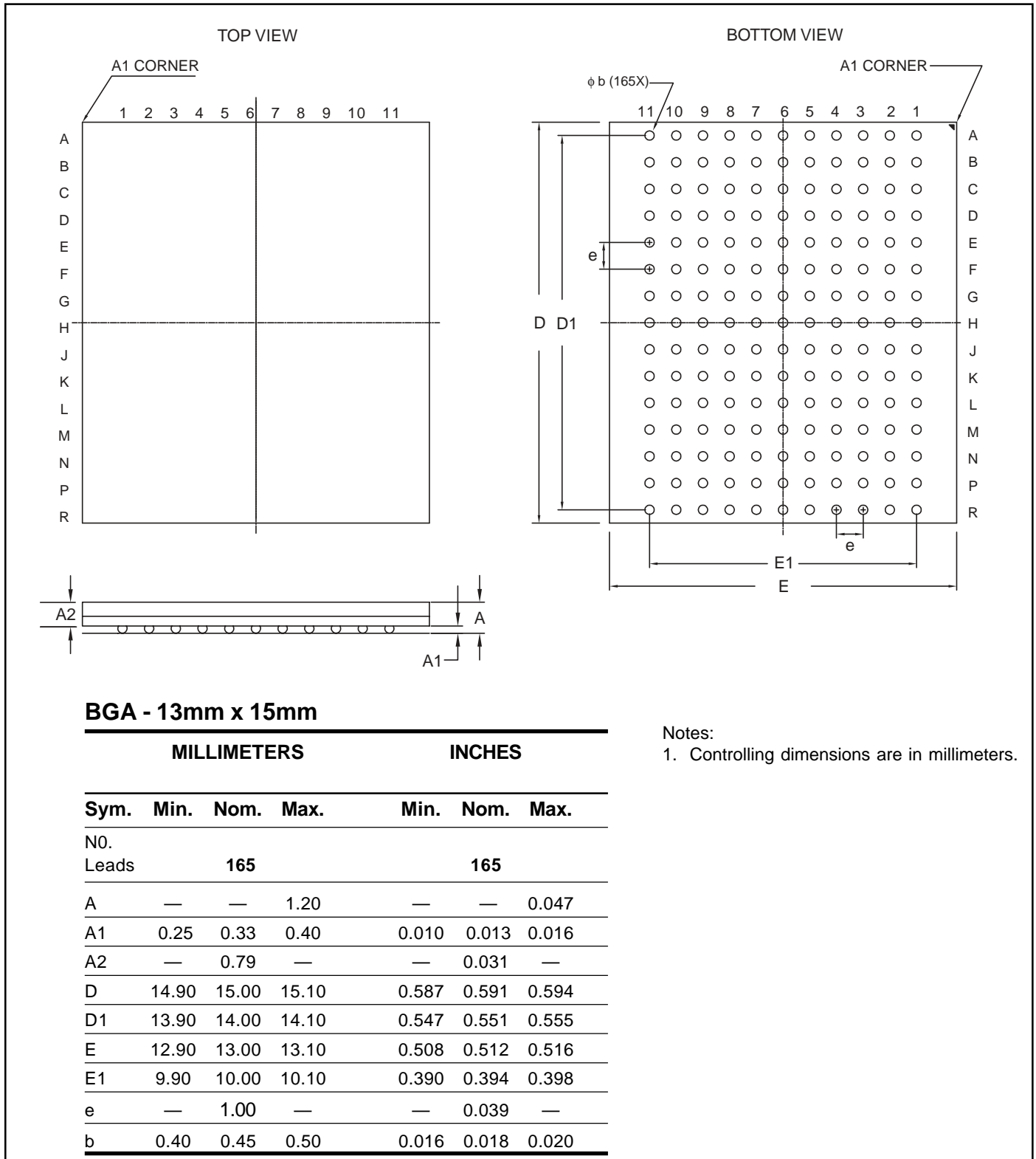

Copyright © 2003 Integrated Silicon Solution, Inc. All rights reserved. ISSI reserves the right to make changes to this specification and its products at any time without notice. ISSI assumes no liability arising out of the application or use of any information, products or services described herein. Customers are advised to obtain the latest version of this device specification before relying on any published information and before placing orders for products.

PACKAGING INFORMATION

TQFP (Thin Quad Flat Pack Package)
Package Code: TQ

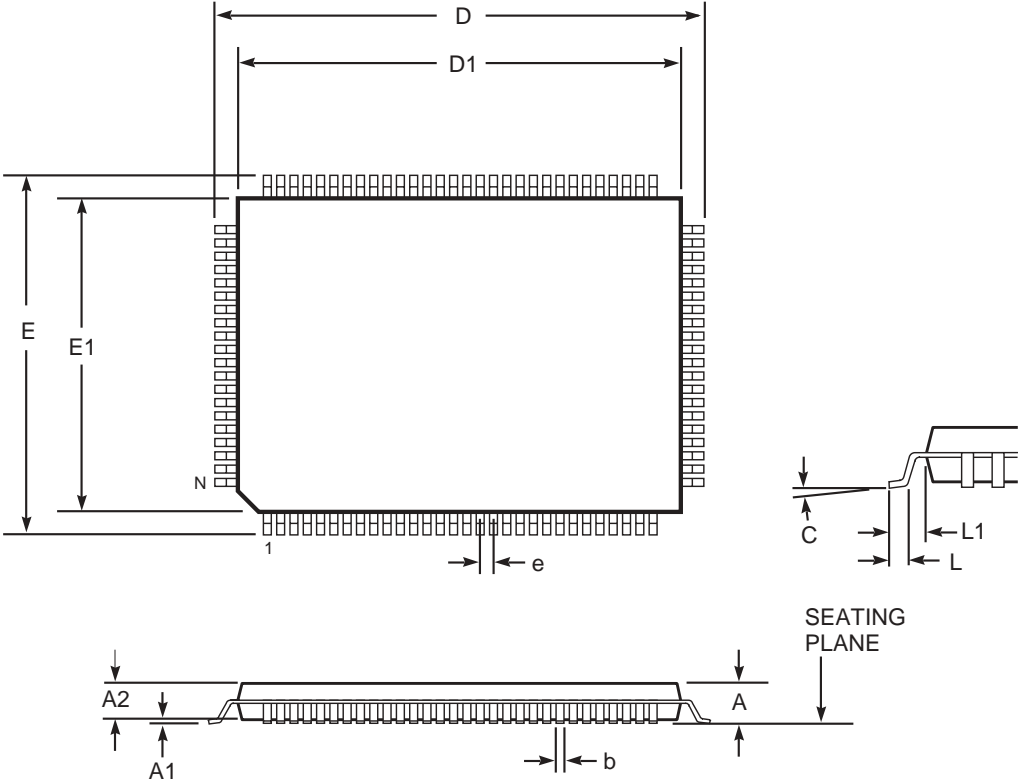

Thin Quad Flat Pack (TQ)									
Symbol	Millimeters		Inches		Symbol	Millimeters		Inches	
	Min	Max	Min	Max		Min	Max	Min	Max
Ref. Std.									
No. Leads (N)	100				128				
A	—	1.60	—	0.063	—	1.60	—	0.063	
A1	0.05	0.15	0.002	0.006	0.05	0.15	0.002	0.006	
A2	1.35	1.45	0.053	0.057	1.35	1.45	0.053	0.057	
b	0.22	0.38	0.009	0.015	0.17	0.27	0.007	0.011	
D	21.90	22.10	0.862	0.870	21.80	22.20	0.858	0.874	
D1	19.90	20.10	0.783	0.791	19.90	20.10	0.783	0.791	
E	15.90	16.10	0.626	0.634	15.80	16.20	0.622	0.638	
E1	13.90	14.10	0.547	0.555	13.90	14.10	0.547	0.555	
e	0.65 BSC		0.026 BSC		0.50 BSC		0.020 BSC		
L	0.45	0.75	0.018	0.030	0.45	0.75	0.018	0.030	
L1	1.00 REF.		0.039 REF.		1.00 REF.		0.039 REF.		
C	0°	7°	0°	7°	0°	7°	0°	7°	

- Notes:**
1. All dimensioning and tolerancing conforms to ANSI Y14.5M-1982.
 2. Dimensions D1 and E1 do not include mold protrusions. Allowable protrusion is 0.25 mm per side. D1 and E1 do include mold mismatch and are determined at datum plane -H-.
 3. Controlling dimension: millimeters.