

# 6RI30E(30A)

## POWER DIODE MODULE

600V,800V / 30A

6 in one-package

### Features

- Glass Passivation Chip
- Easy Connection
- Insulated Type

### Applications

- Inverters
- Battery Chargers
- DC Motors
- General Purpose DC Power Supplies

### Outline Drawings, mm

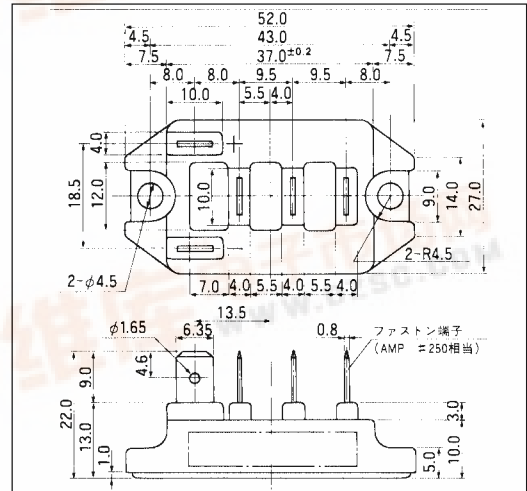

### Inner Circuit Schematic

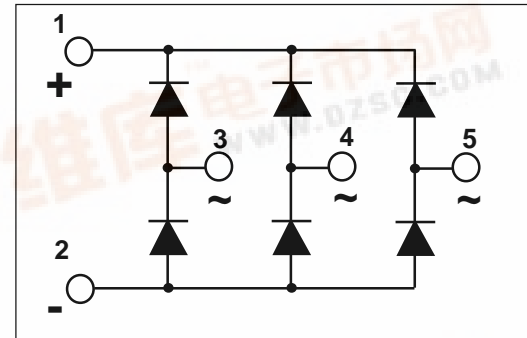

### Maximum ratings and characteristics

#### Absolute maximum ratings

Item	Symbol	Conditions	Rating		Unit
			-060	-080	
Repetitive peak reverse voltage	$V_{RRM}$		600	800	V
Non-repetitive peak reverse voltage	$V_{RSM}$		660	880	V
Average output current	$I_O$	50/60Hz Sine wave, $T_c=97^\circ\text{C}$	30		A
Surge current	$I_{FSM}$	From rated load, Sine wave 10ms	360		A
$I^2t$	$I^2t$	From rated load	520		$\text{A}^2\text{s}$
Operating junction temperature	$T_j$		-40 to +150		$^\circ\text{C}$
Storage temperature	$T_{stg}$		-40 to +125		$^\circ\text{C}$
Isolation voltage	$V_{is}$		AC2000(1min.)		V
Screw torque			1.7 *1		N·m

\*1: Recommendable value : 1.3 to 1.7 N·m(M4)

#### Electrical characteristics ( $T_a=25^\circ\text{C}$ Unless otherwise specified)

Item	Symbol	Conditions	Min.	Typ.	Max.	Unit
Forward voltage drop	$V_{FM}$	$T_j=25^\circ\text{C}$ , $I_{FM}=30\text{A}$			1.10	V
Reverse current	$I_{RRM}$	$T_j=150^\circ\text{C}$ , $V_R=V_{RRM}$			3.0	mA

#### Thermal Characteristics

Item	Symbol	Conditions	Min.	Typ.	Max.	Unit
Thermal resistance	$R_{th(j-c)}$	Junction to case			0.80	$^\circ\text{C}/\text{W}$
	$R_{th(c-f)}$	the base to cooling fin *			0.10	$^\circ\text{C}/\text{W}$

\* : With Thermal Compound



■ Characteristics

Forward Characteristics

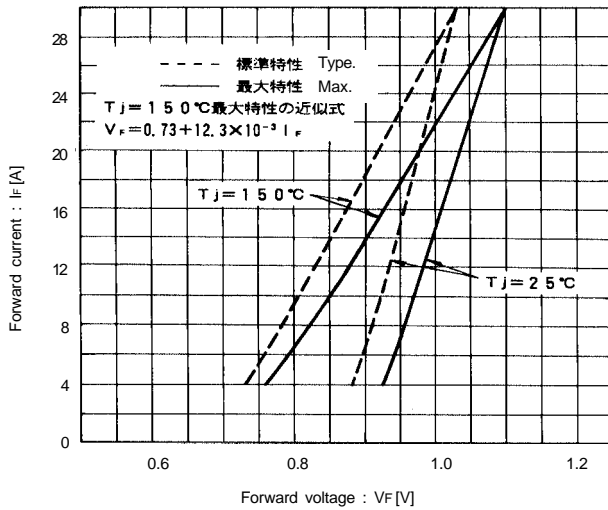

Forward Average Current vs. Power Loss

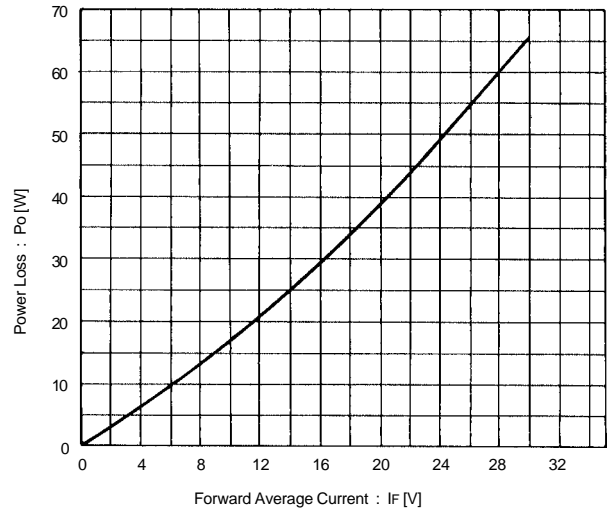

Forward Average Current vs. Case Temperature

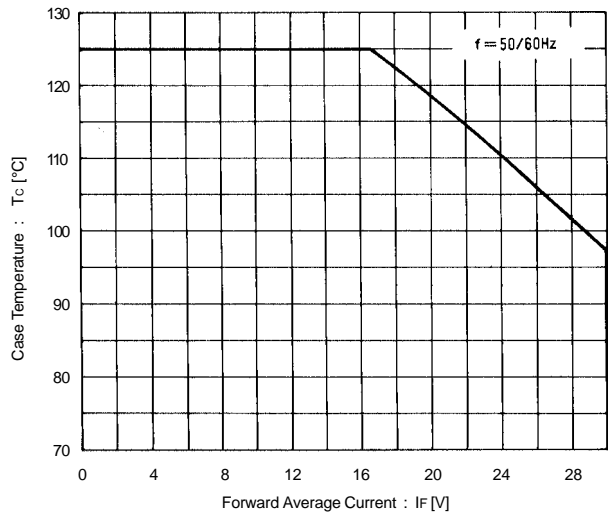

Surge Current

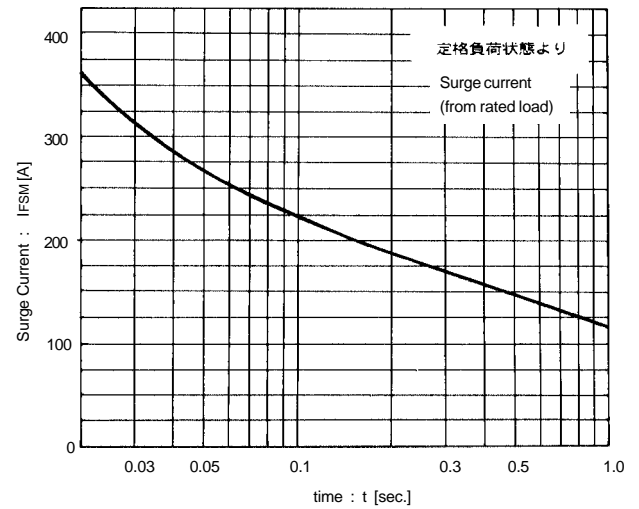

Transient Thermal Impedance

