

MA4SPS402 SurMount[®] Series

M/A-COM Surface Mount Monolithic PIN Diode Chip

Features

- Surface Mount Diode
- No Wirebonds Required
- Rugged Silicon-Glass Construction
- Silicon Nitride Passivation
- Polymer Scratch Protection
- Low Parasitic Capacitance and Inductance
- High Power Handling (Efficient Heatsinking)

Description

M/A-COM's MA4SPS402 is a silicon-glass PIN diode fabricated with M/A-COM's patented HMIC[™] process. This device features two silicon pedestals embedded in a low loss glass. The diode is formed on the top of one pedestal and connections to the backside of the device are facilitated by making the pedestal side walls conductive. Selective backside metalization is applied producing a surface mount device. The topside is fully encapsulated with silicon nitride and has an additional polymer layer for scratch protection. These protective coatings prevent damage to the junction and the anode air-bridge during handling and assembly.

Applications

These devices can be used in series and shunt switches up to 20 GHz where smaller area and profile are required. Low parasitic values of L and C make additional circuit tuning unnecessary. These diodes can also be used for switched pad attenuator circuits.

Case Style ODS-1253^{1,2}

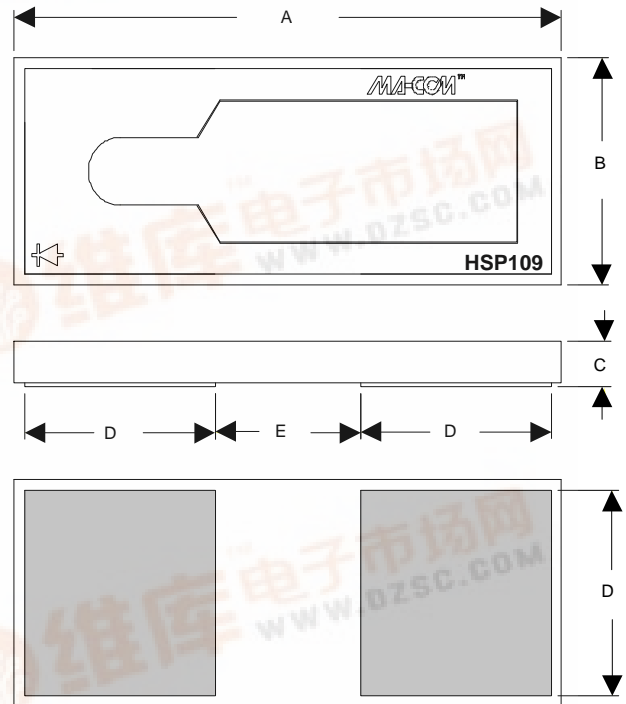

1. Backside metal: 0.1 micron thk. gold.
2. Hatched areas indicate bond pads.

DIM.	INCHES		MILLIMETERS	
	MIN.	MAX.	MIN.	MAX.
A	0.0465	0.0528	1.180	1.340
B	0.0173	0.0236	0.440	0.600
C	0.0040	0.0080	0.102	0.203
D	0.0150	0.0170	0.381	0.432
E	0.0140	0.0160	0.355	0.406

Absolute Maximum Ratings¹

@ T_A = +25°C (unless otherwise specified)

Parameter	Absolute Maximum
Reverse Voltage	-70 V
Forward Current	100 mA
Operating Temperature	-65°C to +150°C
Storage Temperature	-65°C to +150°C
Mounting Temperature	+235°C for 10 seconds

1. Exceeding these limits may cause permanent damage.



Electrical Specifications @ +25°C

Symbol	Test Conditions	Units	Min.	Typ.	Max.
C_T	-40 Volts, 1 MHz ¹	pF		0.034	0.045
C_T	-40 Volts, 1 GHz ^{1,3}	pF		0.041	
R_S	10 mA, 2 MHz ²	Ω		5.0	
R_S	10 mA, 100 MHz ²	Ω		4.6	
R_S	10 mA, 1 GHz ^{2,3}	Ω		5.0	
V_F	1.0 mA	V		0.84	1.00
V_R	10 μ A	V	-70	-120	
I_R	-70V	μ A			10
T_L	10 mA / 6 mA	ns		200	

1. Total capacitance is equivalent to the sum of junction capacitance C_j and parasitic capacitance.
2. Series resistance R_S is equivalent to the total diode series resistance including the junction resistance R_j .
3. R_S and C_p is measured on an HP4291A with die mounted in an ODS-186 package with conductive silver epoxy.

Handling Procedures

All semiconductor chips should be handled with care to avoid damage or contamination from perspiration and skin oils. The use of plastic tipped tweezers or vacuum pickups is strongly recommended for individual components. Bulk handling should insure that abrasion and mechanical shock are minimized.

ESD

These devices very susceptible to ESD and are rated Class 0 (0-199V) per HBM MIL-STD-883, method 3015.7 [$C = 100\text{pF}$ $\pm 10\%$, $R = 1.5\text{k}\Omega \pm 1\%$]. Even though tested die pass 100V ESD, they must be handled in a static-free environment.

Bonding Techniques

Attachment to a circuit board is made simple through the use of surface mount technology. Mounting pads are conveniently located on the bottom surface of these diodes and are removed from the active junction locations. These diodes are well suited for solder attachment onto hard and soft substrates. The use of 80/20 Au/Sn and 60/40 Sn/Pb solder is recommended. Conductive epoxy paste for attachment may also be used, this can be silk-screened, or used with a conductive sheet epoxy.

When soldering these diodes to a hard substrate, hot gas die bonding is preferred. We recommend utilizing a vacuum tip and a force of 60 to 100 grams applied normal to the top surface of the part. When soldering to soft substrates, it is recommended to use a lead-tin interface at the circuit board mounting pads. Position the die so that its mounting pads are aligned with the circuit board's mounting pads. Reflow the solder by heating the circuit trace near the mounting pad while applying 60 to 100 grams of force perpendicular to the top surface of the die.

Since the HMIC[™] glass is transparent, the edges of the mounting pads closest to each other can be visually inspected through the die after attach is completed.

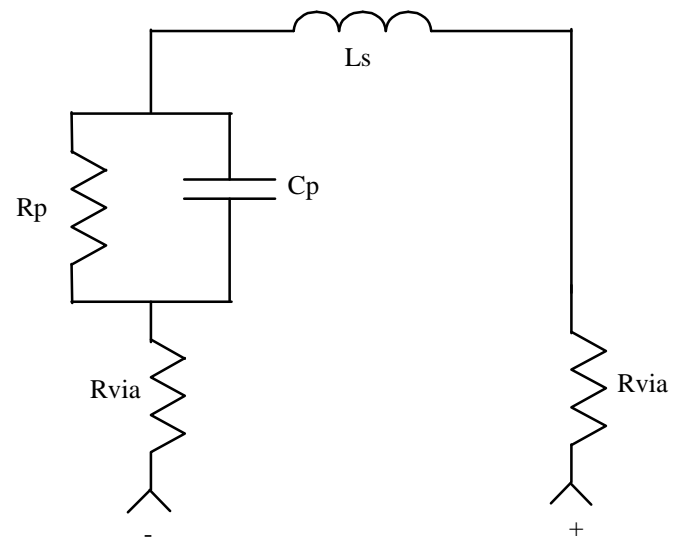
Functional Schematic¹

$$1. R_s = 2 * R_{via} + R_p$$

Typical Performance Curves @ +25°C

Typical Total Resistance R_S vs. Forward Current and Frequency

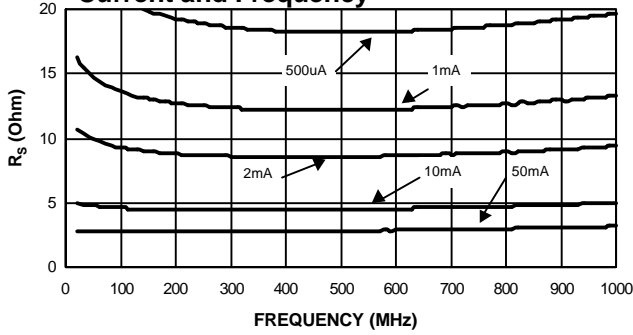

Typical Total Capacitance C_P vs. Reverse Voltage and Frequency

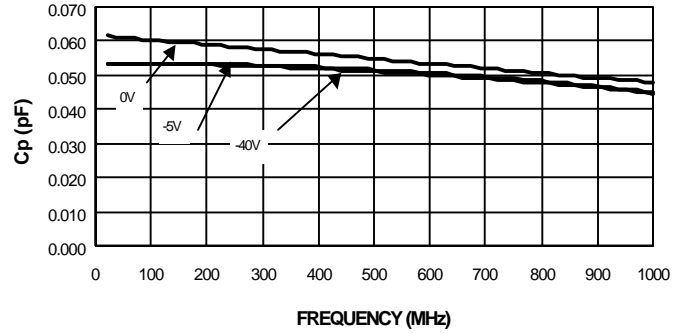

C_P vs. V @ 100 MHz and 1 GHz

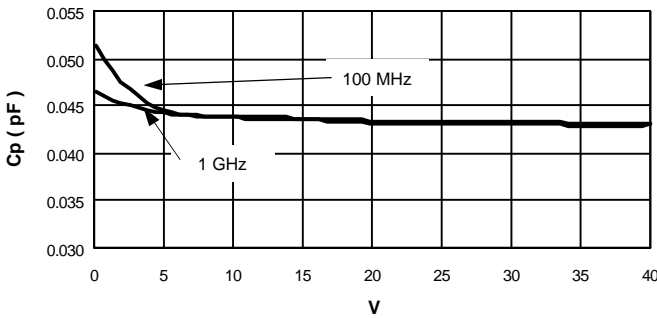

R_P vs. V @ 100 MHz and 1 GHz

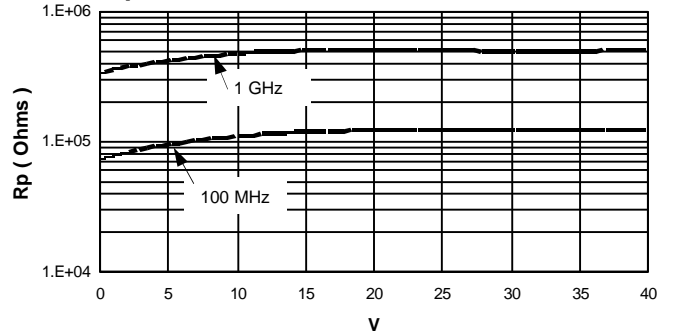

R_S vs. I @ 100 MHz and 1 GHz

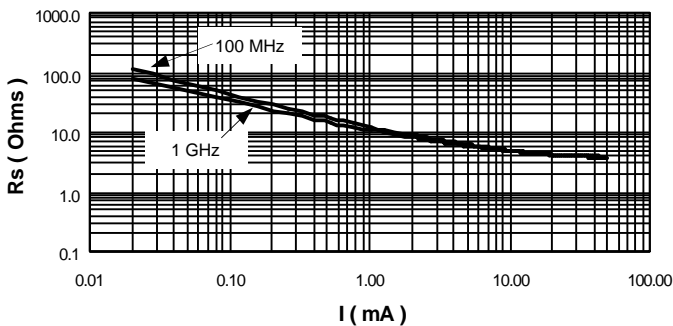

L_S vs. Frequency @ 10 mA

