

SIEMENS

Silicon Variable Capacitance Diode

BB 641

- For VHF Hyperband TV/TR tuners
- High capacitance ratio
- Low series resistance

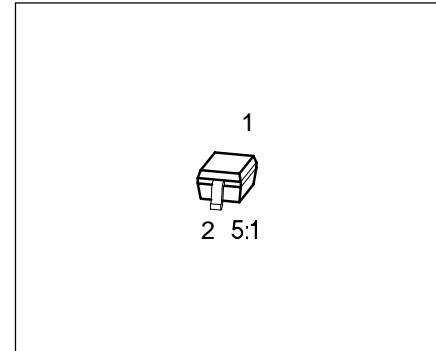

Type	Ordering Code (tape and reel)	Pin Configuration			Marking	Package
		1		2		
BB 641	Q62702-B792	C		A	red G	SOD-323

Maximum Ratings

Parameter	Symbol	Values	Unit
Reverse voltage	V_R	30	V
Reverse voltage ($R \geq 5 \text{ k}\Omega$)	V_{RM}	35	V
Forward current	I_F	20	mA
Operating temperature range	T_{op}	- 55 ... + 150	°C
Storage temperature range	T_{stg}	- 55 ... + 150	°C

Thermal Resistance

Junction-ambient	$R_{th JA}$	≤ 450	K/W
------------------	-------------	------------	-----

Electrical Characteristics

at $T_A = 25\text{ }^\circ\text{C}$, unless otherwise specified.

Parameter	Symbol	Value			Unit
		min.	typ.	max.	

DC Characteristics

Reverse current $V_R = 30\text{ V}$ $V_R = 30\text{ V}, T_A = 85\text{ }^\circ\text{C}$	I_R	– –	– –	20 200	nA
Diode capacitance $V_R = 1\text{ V}, f = 1\text{ MHz}$ $V_R = 28\text{ V}, f = 1\text{ MHz}$	C_T	62 2.65	69 2.88	76 3.1	pF
Capacitance ratio $V_R = 1\text{ V}, 28\text{ V}, f = 1\text{ MHz}$	C_{T1}/C_{T28}	22	24	–	–
Capacitance matching $V_R = 1\text{ V} \dots 28\text{ V}, f = 1\text{ MHz}$	$\Delta C_T/C_T$	–	–	2.5	%
Series resistance $C_T = 30\text{ pF}, f = 100\text{ MHz}$	r_s	–	1.55	–	Ω
Series inductance	L_s	–	1.8	–	nH

Package Outline

SOD-323

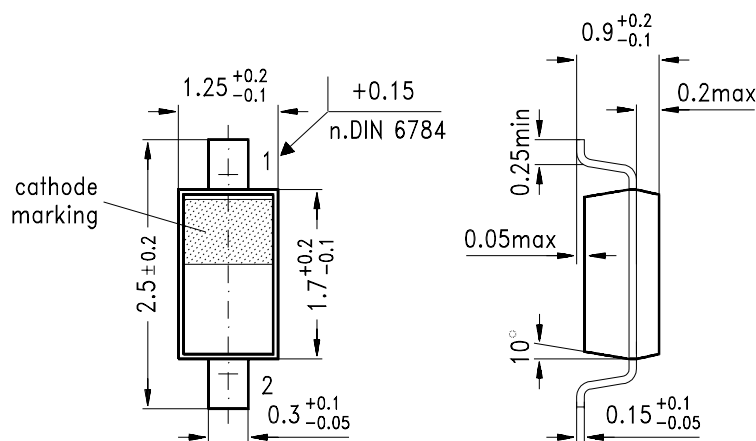

Dimensions in mm

GPS05556

Diode capacitance $C_T = f(V_R)$

$f = 1 \text{ MHz}$

