

Stereo sound controller IC

BA3853BFS

The BA3853BFS is a dual-channel electronic volume controller built around a low-noise, low-distortion VCA. It is suited for car-audio applications, and has performance that rivals mechanical-type volume controllers.

In addition to volume control, the IC includes all functions required for controlling sound quality, to allow more compact designs with far fewer components.

●Applications

Car audio systems

●Features

- 1) Provides electronic control for volume, balance, fader, tone (bass and treble), and loudness.
- 2) The volume control circuit is a low-distortion, low-noise VCA circuit that uses DC voltage for control. The IC uses an internally-generated, temperature-compensated reference voltage and is capable of dual-channel control with the addition of a single potentiometer.
- 3) Available in an SSOP-24 package that is ideal for compact designs.

●Absolute maximum ratings (Ta = 25°C)

Parameter	Symbol	Limits	Unit
Power supply voltage	V _{cc}	10.0	V
Power dissipation	P _d	800*	mW
Operating temperature	T _{opr}	-40~+85	°C
Storage temperature	T _{stg}	-55~+125	°C

*When mounted on a PC board.

●Recommended operating conditions (Ta = 25°C)

Parameter	Symbol	Limits	Unit
Power supply voltage	V _{cc}	*7.0~9.5	V

*For basic operation at 25°C.



● Block diagram

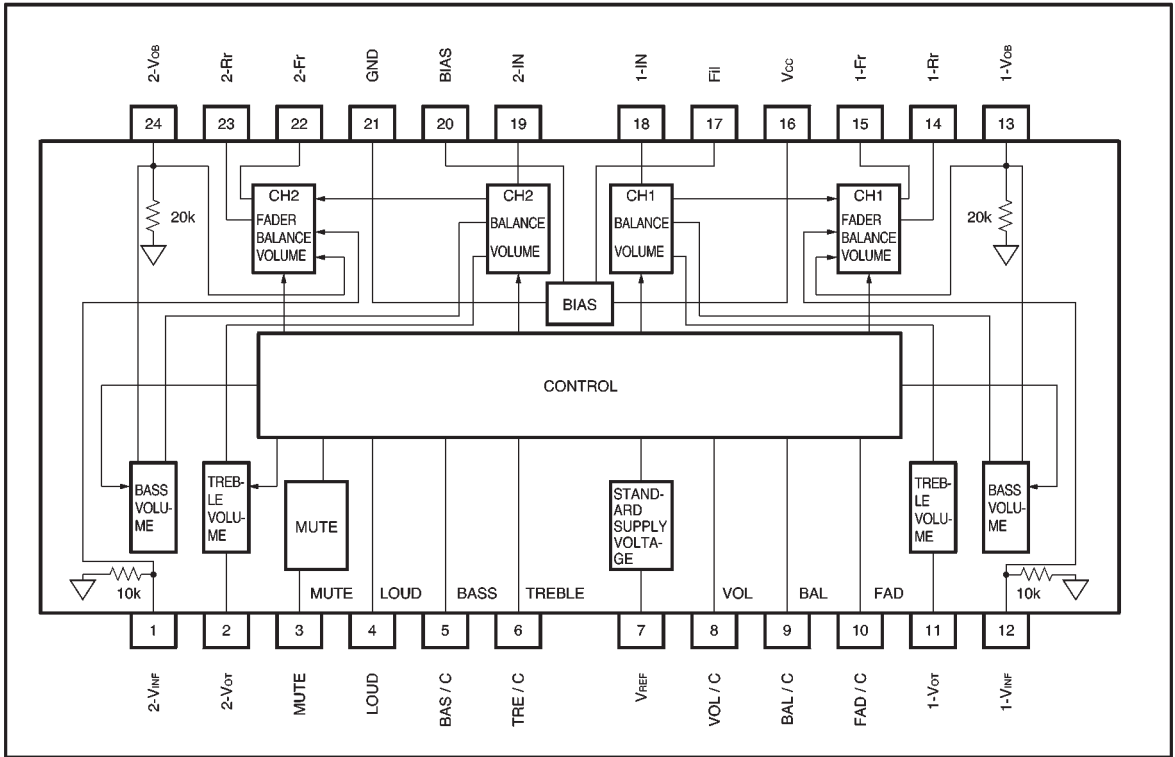

● Pin descriptions and input / output circuits

Pin No.	Pin name	Function	Equivalent circuit
1 12	2— V_{INF} 1— V_{INF}	For connection to filter.	
24 13	2— V_{OB} 1— V_{OB}	Bass signal input.	
2 11	2— V_{OT} 1— V_{OT}	Treble signal input.	
3	MUTE	Mute control. Mute off when High (4.9V or more Typ.) Mute on when Low (0.5V or less Typ.)	
4	LOUD	Loudness control. Works together with the main volume when on. Loudness off when High (4.9V or more Typ.) Loudness on when Low (0.5V or less Typ.)	
8 9 10	VOL / C BAL / C FAD / C	Signal adjustment controls. VOL/C: main volume BAL/C: balance FAD/C: fader	

Pin No.	Pin name	Function	Equivalent circuit
5 6	BAS / C TRE / C	Tone signal adjustment controls. BAS/C: bass region TRE/C: treble region	
7	V _{REF}	5V regulator output. To prevent oscillation, a capacitor must be connected to the output. The output pin has a pre-charge/discharge circuit.	
14 15 23 22	1—Rr 1—Fr 2—Fr 2—Rr	Main volume and fader outputs. The output impedance is approximately 5Ω in the audio range. 1-Rr: CH1 rear output 1-Fr: CH1 front output 2-Fr: CH2 front output 2-Rr: CH2 rear output	
18 19	1—IN 2—IN	Main volume input. The input impedance is designed to be 47kΩ (typ.).	
17	Fil	Filter input. The filter input voltage is set at about 1/2 V _{cc} by a resistor divider. Connect a capacitor of about 10 μF to the filter input pin. This pin has a pre-charge/discharge circuit.	
20	BIAS	Bias output. When using bias, design the PCB layout so that the wiring impedance is as small as possible. The output impedance is approximately 1Ω in the audio range.	
16	V _{cc}	Power supply	
21	GND	Ground. Connected to the IC substrate.	

- Electrical characteristics (unless otherwise noted, $T_a = 25^\circ\text{C}$, $V_{CC} = 8\text{V}$, $f = 1\text{kHz}$, $\text{BW} = 20\text{Hz to } 20\text{kHz}$, $\text{VOL} / \text{C} = \text{MAX}$, $\text{TONE} = \text{ALL FLAT}$, $\text{FAD} / \text{C} = \text{FLAT}$, $\text{BAL} / \text{C} = \text{FLAT}$, $\text{LOUD} = \text{OFF}$, and $\text{MUTE} = \text{OFF}$)

Parameter	Symbol	Min.	Typ.	Max.	Unit	Coniditions
Quiescent current	I_o	6	14	22	mA	No signal
Maximum input	V_{im}	1.35	1.5	—	Vrms	$\text{TDH}=1\%$, $\text{VOL}=-20\text{dB (ATT)}$
Maximum output	V_{om}	1.35	1.5	—	Vrms	$\text{TDH}=1\%$
Voltage gain	G_V	-2	0	2	dB	$V_{IN}=1\text{Vrms}$
Loudness pin current	I_{ILO}	—	0.002	0.12	μA	4pin
Maximum attenuation	ATT	90	110	—	dB	$V_o=1\text{Vrms}$
Balance attenuation	V_{BAL}	74	105	—	dB	$V_o=1\text{Vrms}$
Fader attenuation	V_{FD}	74	80	—	dB	$V_o=1\text{Vrms}$
Crosstalk	V_{CT}	74	100	—	dB	$V_o=1\text{Vrms}$, $\text{BPF}=400\text{Hz}\sim 30\text{kHz}$
Bass control width	V_{Bmax}	10	13	16	dB	$f=100\text{Hz}$, $V_{IN}=100\text{mVrms}$
	V_{Bmin}	-16	-13	-10	dB	$f=100\text{Hz}$, $V_{IN}=100\text{mVrms}$
Treble control width	V_{Tmax}	11	14	17	dB	$f=10\text{kHz}$, $V_{IN}=100\text{mVrms}$
	V_{Tmin}	-17	-14	-11	dB	$f=10\text{kHz}$, $V_{IN}=100\text{mVrms}$
Loudness control (-30dB ATT)	V_{LB}	6	8	10	dB	Change for LOUD OFF/ON ($f=100\text{Hz}$)
	V_{LT}	4	6	8	dB	Change for LOUD OFF/ON ($f=10\text{kHz}$)
Mute attenuation	V_{MT}	90	110	—	dB	$V_o=1\text{Vrms}$ *
Total harmonic distortion	THD	—	0.007	0.1	%	$V_o=0.2\text{Vrms}$, $\text{BPF}=400\text{Hz}\sim 30\text{Hz}$
Output noise voltage	V_{No1}	—	10	25	μVrms	No signal, $\text{VR}=0\text{dB}$, $\text{Rg}=0$ *
Output noise voltage at full boost	V_{No2}	—	90	120	μVrms	No signal, $\text{TONE}=\text{ALL MAX}$ $\text{VOL}=\text{MAX}$, $\text{Rg}=0$ *
Residual output noise voltage	V_{MNo}	—	2	10	μVrms	No signal, $\text{VR}=-\infty$, $\text{Rg}=0$ *
Reference power supply output voltage	V_{REF}	4.7	5	5.3	V	$I_{REF}=3\text{mA}$
Reference power supply current output capacity	I_{REF}	3	—	—	mA	$V_{REF}>4.7\text{V}$
Control pin current	I_{INO}	—	0.06	0.5	μA	5, 6, 8, 9, 10pin
Mute pin current	I_{MO}	—	0.02	0.12	μA	MUTE ON 3pin
Channel balance	G_{CB}	-2	0	+2	dB	$V_{IN}=1\text{Vrms}$
Bias reference voltage	BV_{REF}	3.8	4.0	4.2	V	$B I_{REF}=\pm 1\text{mA}$
Bias reference current capacity	$B I_{REF}$	1	—	—	mA	$3.8\text{V}<BV_{REF}<4.2\text{V}$

*Measurements made using Matsushita Communications Industrial Co., Ltd. VP-690A
(average value detected, effective value shown).

©Not designed for radiation resistance.

Operating specifications

- (1) Input and output signals have the same phase.
- (2) Maximum loudness control variation occurs at -30dB ATT. At -10dB ATT, the variation is 0dB.
- (3) For loudness operation during tone adjustment, arithmetic processing is performed with the maximum tone variation amount.

● Measurement circuit

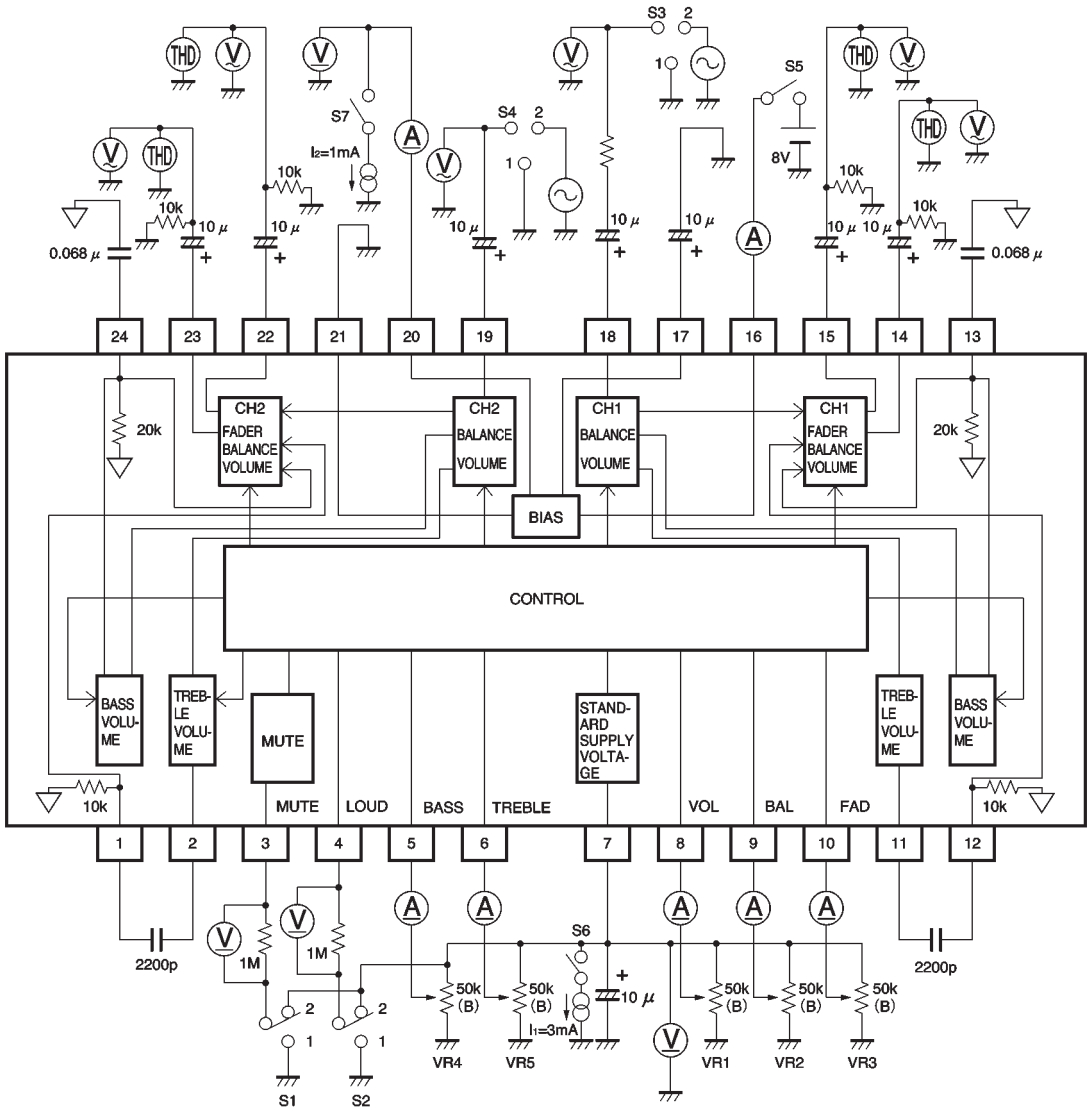

Fig.1

● Measurement circuit switch operation

Parameter	S1	S2	S3	S4	S5	VR1	VR2	VR3	VR4	VR5	Remarks
Quiescent current	2	2	1	1	ON	MAX	1 / 2	1 / 2	1 / 2	1 / 2	—
Maximum input			2	2		2.2V					—
Maximum output						MAX					—
Voltage gain						↓					—
Maximum attenuation						A→C	↘				—
Balance attenuation						MAX	B→A B→C	↘			—
Fader attenuation			↘	↘			1 / 2	B→A B→C			—
Crosstalk			1,2	2,1				1 / 2	↘		*1
Bass control width boost			2	2					B→A		f=100Hz
Bass control width cut									B→C	↘	f=100Hz
Treble control width boost								1 / 2	B→A		f=10kHz
Treble control width cut		↘				↘			B→C		f=10kHz
Loudness control	↘	1				1.8V				1 / 2	f=100Hz f=10kHz
Mute attenuation	2→1	2				MAX					—
Total harmonic distortion	2		↘	↘							—
Output noise voltage			1	1					↘	↘	—
Output noise voltage at full boost						↘			MAX	MAX	—
Residual output noise voltage						MIN			1 / 2	1 / 2	—
Reference power supply output voltage						MAX					S6 : ON
Control pin current											
Bias reference voltage	↘	↘	↘	↘	↘	↘	↘	↘	↘	↘	S7 : ON

*1 When SW3=1, SW4=2, and when SW3=2, SW4=1

A, B and C in the table refer to the following:

A: Max. volume

B: 1 / 2 volume

C: Min. volume

●Circuit operation

- (1) As shown is the block diagram, the main circuit blocks are the main volume (front and rear), tone control (bass and treble), and balance and fader. Signal control for each block is possible with a DC voltage.
- (2) The main volume is comprised of a front volume and rear volume controller. The front volume controller has 18dB of attenuation.

- (3) The tone filter is an external CR circuit. Refer to item 5 of the application notes regarding the component values.
- (4) The loudness is set by a calculation based on the tone control current. Refer to control curves item 3 of the application notes.
- (5) The control curves for the balance and fader are given in the measurement data.

●Application example

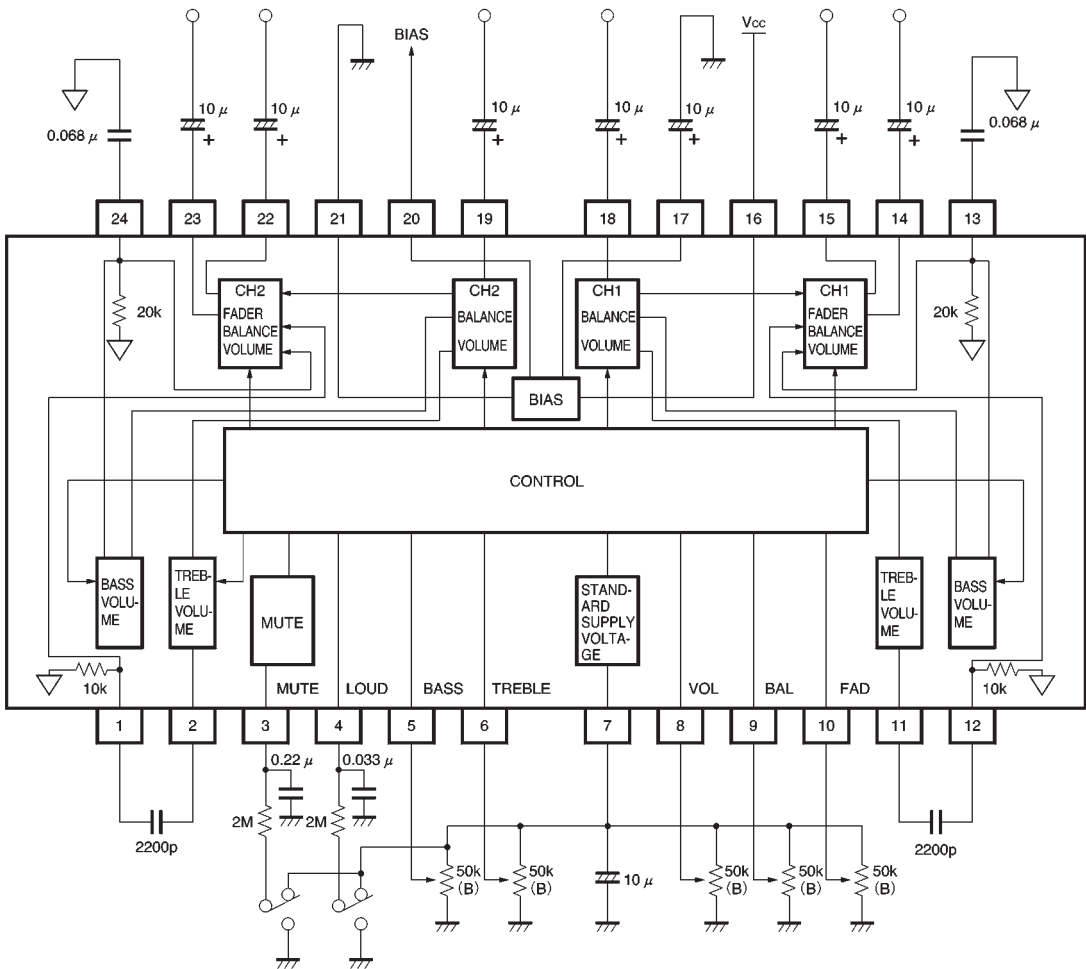

Fig.2

● External components

(1) Mute and loudness circuit components

Select the values for the mute and loudness on / off pin components to suit the product that you are designing. The value of the resistor should be 2.2MΩ or less.

Set the circuit time constant as follows:

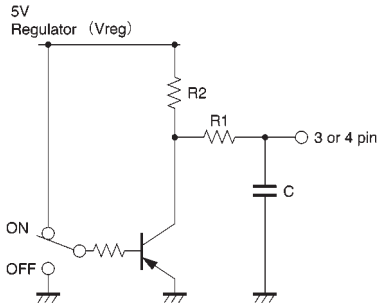

Fig.3

(2) External filter circuits

The filter circuits are built using passive components, and the resistors for both the bass and treble filters are on the chip. Construct the circuits shown below.

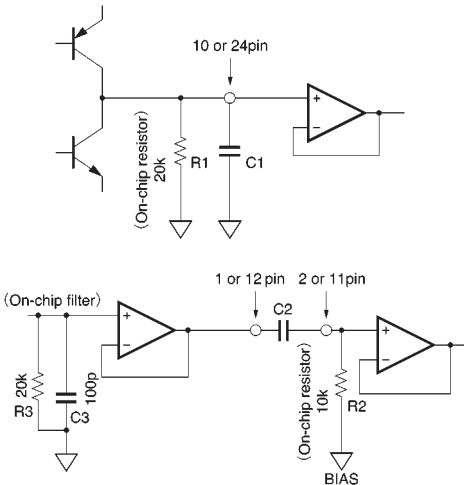

Fig.4

Filter cutoff frequencies

The circuits given above have the following frequency characteristics.

When using a switch as illustrated in the circuit diagram, set the values for C and R in the time-constant circuit as follows:

1) When the switch is on (rise)

$$V = V_{reg} \text{EXP} \left(- \frac{t}{CR_1^2 / (R_1 + R_2)} \right)$$

2) When the switch is off (fall)

$$V = V_{reg} (1 - \text{EXP} (- \frac{t}{R_1 C_2}))$$

V: pin 3 or pin 4 voltage

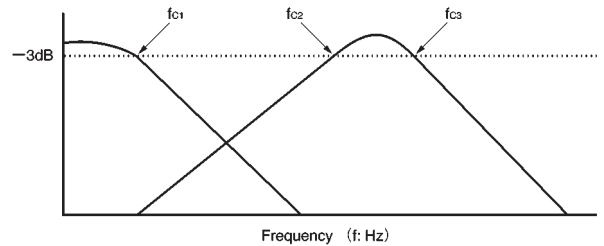

Fig.5

1) Bass filter cutoff frequency

$$f_{c1} = \frac{1}{2\pi C_1 R_1} = \frac{1}{2\pi C_1 \times 20k\Omega}$$

2) Treble filter cutoff frequency

High-pass filter side

$$f_{c2} = \frac{1}{2\pi C_2 R_2} = \frac{1}{2\pi C_2 \times 10k\Omega}$$

Low-pass filter side

$$f_{c3} = \frac{1}{2\pi C_3 R_3} = \frac{1}{2\pi C_3 \times 100pF \times 20k\Omega} = 80kHz$$

The tone control circuit is designed to give a change of ±15dB (Typ.) for the frequency that you wish to boost or cut at the peak and bottom of the frequency characteristic. Design the filter with due consideration to the frequency characteristics. The values for the filter given in the application circuit have been selected to give sufficient boost and cut at f = 100Hz and f = 10kHz.

●Application notes

(1) Power supply voltage range

Operation of the basic functions of the application example circuit are guaranteed if operated within the stipulated power supply voltage and ambient temperature ranges. Rohm cannot guarantee the ratings for the electrical characteristics, but these will not change radically if the circuit is operated within the stipulated power supply voltage and ambient temperature ranges.

(2) Mute circuits

Both the main volume and fader volume circuits have a built-in mute circuit. Mute is applied to all output pins.

Mute logic

VOL \ MUTE	L	H
MIN	ON	ON
MAX	ON	OFF

(3) Loudness control

1) The loudness circuit is designed to work together with the main volume.

2) Maximum loudness change occurs when the signal attenuation is -30dB or lower. Up to a signal attenuation of -10dB , the circuit is designed to have a change in loudness of 0dB .

3) For signal attenuation between -10dB to -30dB , the change in loudness is smaller approaching -10dB , and gets larger approaching -30dB .

4) When loudness is operated during tone adjustment, if the amount of boost due to the combined tone boost and loudness exceeds the maximum boost, the circuit design ensures that the amount of loudness change will not exceed the maximum amount of tone boost (see Figs. 6 and 7).

5) Loudness is on when the pin voltage is below 2.5V , and off above 2.5V .

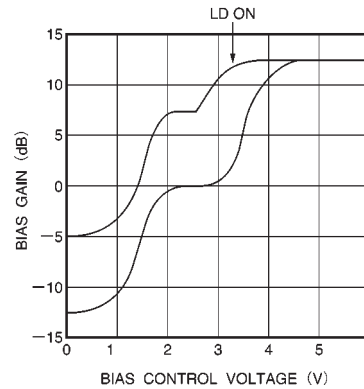

Fig.6 Bass gain vs. bass control voltage

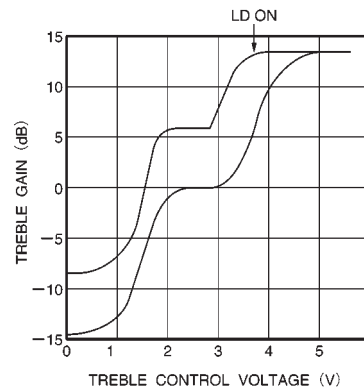

Fig.7 Treble gain vs. treble control voltage

(4) Balance / fader

1) Balance control curve

The balance control curve has been designed so that at above 2.8V , channel 1 (1-Fr, 1-Rr) is attenuated, and at below 2.2V , channel 2 (2-Fr, 2-Rr) is attenuated.

2) Fader control curve

The fader control curve has been designed so that at below 2.2V , the front (1-Fr, 2-Fr) is attenuated, and at above 2.8V , the rear (1-Rr, 2-Rr) is attenuated.

(5) Input / output circuits

Buffers are used before and after the signal input and output pins.

● External dimensions (Units: mm)

