

Reversible motor driver

BA6219B / BA6219BFP-Y

The BA6219B and BA6219BFP-Y are reversible-motor drivers suitable for brush motors. Two logic inputs allow four output modes: forward, reverse, idling, and braking. The motor revolving speed can be set arbitrarily by controlling the voltage applied to the motor.

● Applications

VCRs and cassette tape recorders

● Features

- 1) Large output current. ($I_o=2.2A$ Max.)
- 2) Built-in thermal shutdown circuit.
- 3) Built-in output voltage setting pins.
- 4) Small standby supply current.

● Block diagram

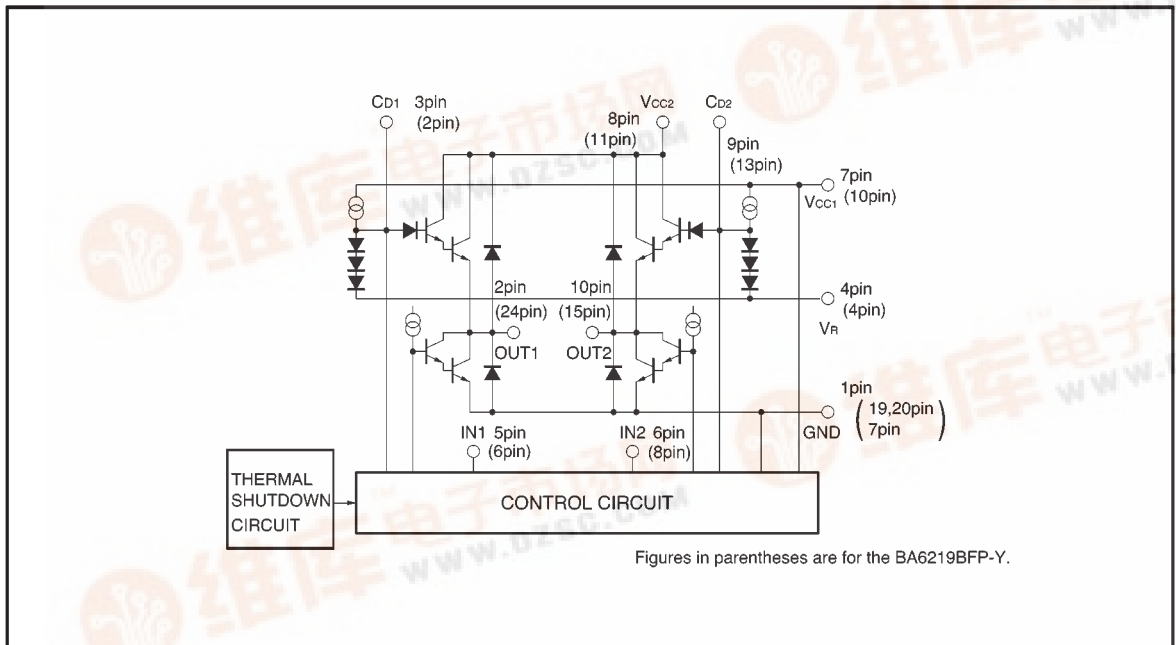

● Absolute maximum ratings (Ta = 25°C)

Parameter	Symbol	Limits	Unit
Power supply voltage	V _{CC1} , V _{CC2}	24	V
Power dissipation	BA6219B	2200*1	mW
	BA6219BFP - Y	1450*2	
Operating temperature	T _{opr}	-20~+75	°C
Storage temperature	T _{stg}	-50~+125	°C
Output current	I _o	2.2*3	A
Input voltage	V _{IN}	-0.3~V _{CC1}	V

*1 Reduced by 22 mW for each increase in Ta of 1°C over 25°C.

*2 When mounted on a 90 X 50 X 1.6 mm glass epoxy board.
Reduced by 14.5 mW for each increase in Ta of 1°C over 25°C.

*3 500 μs pulse with a duty ratio of 1%.

● Recommended operating conditions (Ta = 25°C)

Parameter	Symbol	Min.	Typ.	Max.	Unit
Operating power supply voltage	V _{CC1}	8	—	18	V
	V _{CC2}				

● Electrical characteristics (unless otherwise noted, Ta = 25°C and V_{CC} = 12V)

Parameter	Symbol	Min.	Typ.	Max.	Unit	Conditions
Current dissipation 1	I _{CC1}	—	1.2	2.5	mA	Both input pins LOW
Current dissipation 2	I _{CC2}	—	16	35	mA	One input pin HIGH, the other LOW
Current dissipation 3	I _{CC3}	—	25	60	mA	Both input pins HIGH
Input threshold voltage	V _{TH}	1.0	2.0	3.0	V	Low level is 1 V or less, HIGH level is 3 V or more
Output high level voltage	V _H	6.5	—	—	V	R _L =60Ω, Z _D =6.8V
Output low level voltage	V _L	—	—	1.2	V	R _L =60Ω

● Electrical characteristic curves

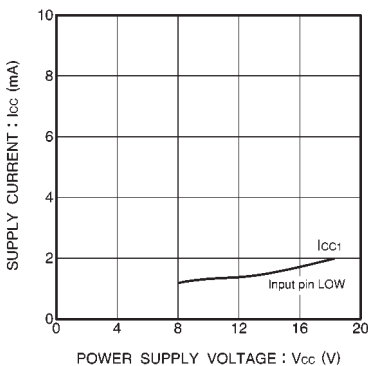

Fig.1 Current dissipation 1 vs. power supply voltage

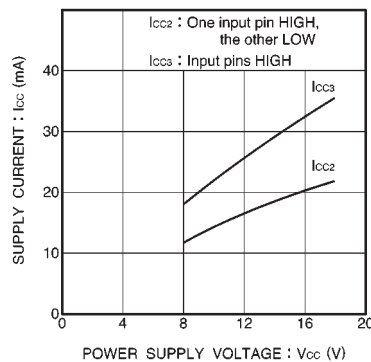

Fig.2 Current dissipation 2,3 vs. power supply voltage

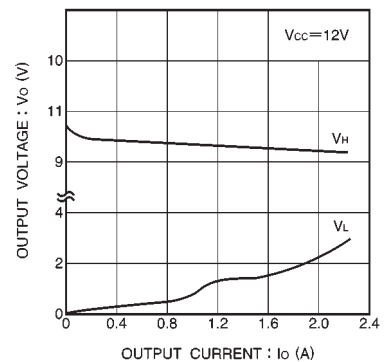

Fig.3 Output voltage vs. output current

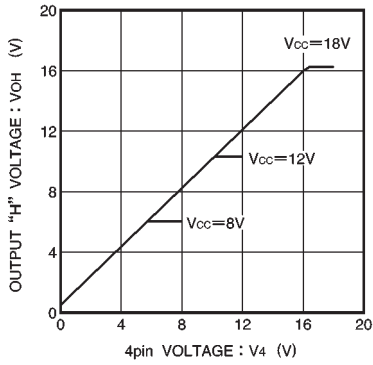

Fig.4 Output voltage vs. 4 pin voltage

● Measurement circuits

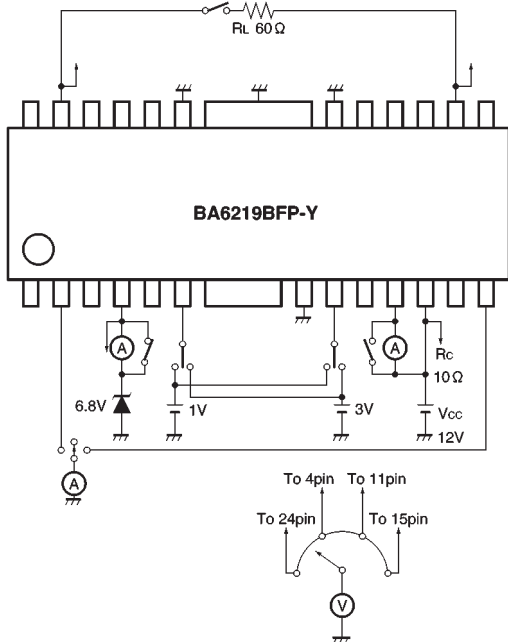

Fig.5

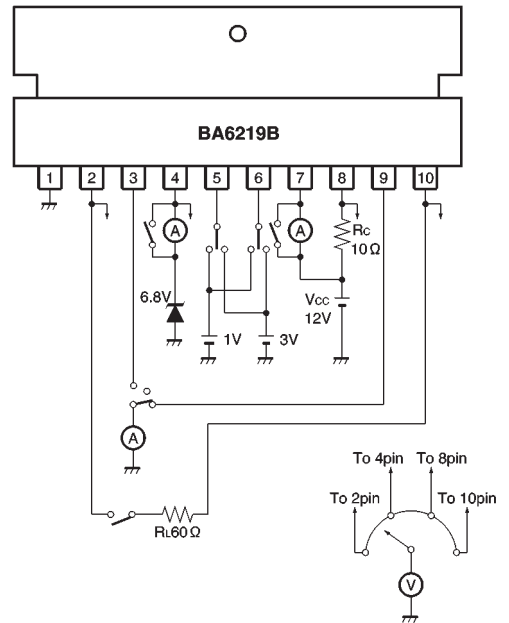

Fig.6

● Input / output truth table

Input		Output		Mode
IN1	IN2	OUT1	OUT2	
L	L	OPEN	OPEN	Idling
H	L	H	L	Forward
L	H	L	H	Reverse
H	H	L	L	Braking

Note: HIGH level input is 3.0 V or more.

LOW level input is 1.0 V or less.

Motor driver ICs

BA6219B / BA6219BFP-Y

● Pin descriptions (BA6219BFP-Y)

Pin No.	Pin name	Function
1	—	N.C.
2	C _{D1}	Capacitor connection pin for preventing both output transistors being turned on at the same time
3	—	N.C.
4	V _R	Output HIGH voltage setting
5	—	N.C.
6	IN1	Logic input
7	GND	GND
8	IN2	Logic input
9	—	N.C.
10	V _{CC1}	Small signal section power supply
11	V _{CC2}	Motor output power supply
12	—	N.C.
13	C _{D2}	Capacitor connection pin for preventing both output transistors being turned on at the same time
14	—	N.C.
15	OUT2	Motor output
16	—	N.C.
17	—	N.C.
18	—	N.C.
19	GND	GND
20	GND	GND
21	—	N.C.
22	—	N.C.
23	—	N.C.
24	OUT1	Motor output
25	—	N.C.
F _{IN}	GND	GND

(BA6219B)

Pin No.	Pin name	Function
1	GND	GND
2	OUT 1	Motor output
3	C _{D1}	Capacitor connection pin for preventing both output transistors being turned on at the same time
4	V _R	Output HIGH voltage setting
5	IN1	Logic input
6	IN2	Logic input
7	V _{CC1}	Control circuit power supply
8	V _{CC2}	Output power supply
9	C _{D2}	Capacitor connection pin for preventing both output transistors being turned on at the same time
10	OUT 2	Motor output

* All the GND pins have to be connected.

● Operation notes

(1) A schematic for the internal circuit associated with the output voltage setting pin (Pin 4) is shown in Fig. 7.

The maximum output voltage (V_{OMAX}) is given by :

$$V_{OMAX} = V_{CC1} - V_{SAT(Q1)} - V_{BE(Q2)} - V_{BE(Q3)} - V_{BE(Q4)}$$

For the condition of V_R being equal to or less than V_{OMAX} , the relationship between the output voltage (V_o) and the pin 4 voltage is given by :

$$V_o = V_R + \{(V_{BE(Q5)} + V_{BE(Q6)} + V_{BE(Q7)}) - (V_{BE(Q2)} + V_{BE(Q3)} + V_{BE(Q4)})\}$$

Though ΔV_{BE} depends on the output power supply, V_o is nearly equal to V_R .

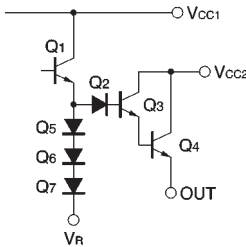

Fig.7

(2) Thermal shutdown circuit

The thermal shutdown circuit turns off the driver output if the chip temperature rises to about 180°. The shutdown signal is not latched.

(3) Power supply impedance

When the motor stops or starts, a rush current flows in the VCC and GND lines. Depending on the way of connecting a power supply decoupling capacitor (100μF), the control input voltage may become a negative value or the supply voltage may drop to below the output voltage. This can cause erratic operations due to parasitic effects. Make sure that pin voltages will not exceed the supply voltage by more than 0.3V or will not become less than the GND pin voltage by more than 0.3V.

(4) V_{CC1} , V_{CC2} , and V_R are related to each other as shown in the output circuit diagram of Fig. 8. Their values should be kept within the following ranges.

Operating supply voltage ranges

Pin	Voltage	Unit
V_{CC1}	8~18	V
V_{CC2}	8~18	V
V_R	Indicated in the following	—

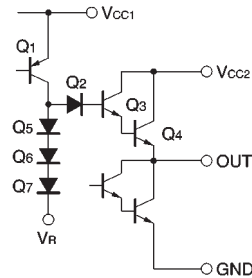

Fig.8

1) When the output voltage control pin (pin 4) is used

$$V_R < V_{CC1} - (V_{SAT(Q1)} + V_{BE(Q5)} + V_{BE(Q6)} + V_{BE(Q7)}) \doteq V_{CC1} - 2.5V$$

$$V_R < V_{CC2} - \{(V_{SAT(Q3)} - V_{BE(Q3)} - V_{BE(Q2)}) + (V_{BE(Q5)} + V_{BE(Q6)} + V_{BE(Q7)})\} \doteq V_{CC2} - 1V$$

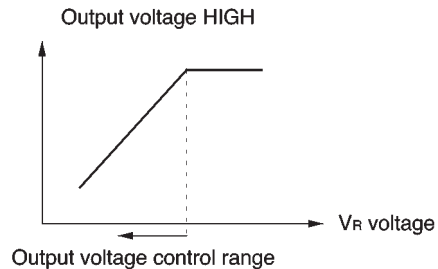
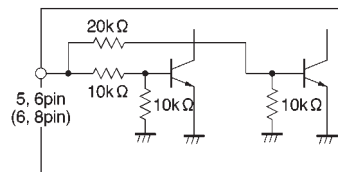

Fig.9

2) When the output voltage control pin (pin 4) is not used, V_R is either short-circuited to V_{CC1} or left OPEN.

(5) Input circuit



Figures in parentheses are for the BA6219BFP-Y

Fig.10

(6) The quality of these products have been carefully checked; however, use of the products with applied voltages, operating temperatures, or other parameters that exceed the absolute maximum rating given may result in the damage of the IC and the product it is used in. If the IC is damaged, the short mode and open modes cannot be specified, so if the IC is to be used in applications where parameters may exceed the absolute maximum ratings, then be sure to incorporate fuses, or other physical safety measures.

(7) Input pins

Voltage should never be applied to the input pins when the V_{CC} voltage is not applied to the IC. Similarly, when V_{CC} is applied, the voltage on each input pin should be less than V_{CC} and within the guaranteed range for the electrical characteristics.

(8) Back-rush voltage

Depending on the ambient conditions, environment, or motor characteristics, the back-rush voltage may fluctuate. Be sure to confirm that the back-rush voltage will not adversely affect the operation of the IC.

(9) Power dissipation

The power dissipation will fluctuate depending on the mounting conditions of the IC and the ambient environment. Make sure to carefully check the thermal design of the application where these ICs will be used.

(10) Power consumption

The power consumption by the IC varies widely with the power supply voltage and the output current. Give full consideration to the power dissipation rating and the thermal resistance data and transient thermal resistance data, to provide a thermal design so that none of the ratings for the IC are exceeded.

(11) ASO

Make sure that the output current and supply voltage do not exceed the ASO values.

(12) Precautions for input mode switching

To ensure reliability, it is recommended that the mode switching for the motor pass once through the open mode.

(13) There are no circuits built into these ICs that prevent in-rush currents. Therefore, it is recommended to place a current limiting resistor or other physical countermeasure.

(14) If the potential of the output pin sways greatly and goes below the potential of ground, the operation of the IC may malfunction or be adversely affected. In such a case, place a diode between the output and ground, or other measure, to prevent this.

●Application examples

(1) BA6219B

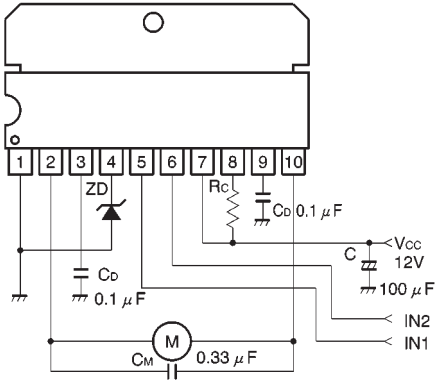

Fig.11

ZD : Zener diode to set output voltage. Use any zener diode that is suitable for your application.

Rc : Resistor used for reducing collector loss and limiting the short-circuit current. A resistance range of 3~10Ω is recommended.

C : Power supply filtering capacitor. Place as near as possible to the Vcc1 pin.

CD : Capacitor to prevent both output transistors being turned on at the same time.

CM : Capacitor to absorb surge voltage and prevent parasitic oscillations.

(2) BA6219BFP-Y

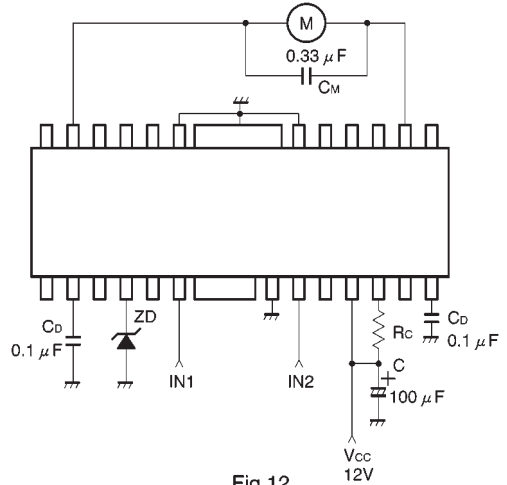
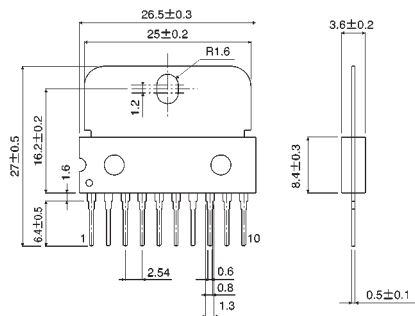

Fig.12

●External dimensions (Units: mm)

BA6219B



HSI10

BA6219BFP-Y

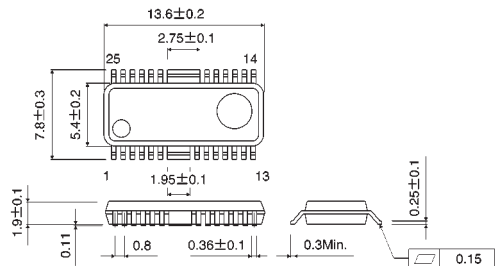

HSOP25