

**NPN BD683****PNP BD684**

SILICON DARLINGTON POWER TRANSISTORS

The BD683 is NPN epitaxial-base transistors in monolithic Darlington circuit for audio and video applications.

They are mounted in Jedec TO-126 plastic package.
PNP complement is BD684.

ABSOLUTE MAXIMUM RATINGS

Symbol	Ratings	Value	Unit
V_{CEO}	Collector-Emitter Voltage	120	V
V_{CBO}	Collector-Base Voltage	140	V
V_{EBO}	Emitter-Base Voltage	5	V
I_C	Collector Current	I_C	4
		I_{CM}	6
I_B	Base current (peak value)	I_{BM}	0.1
P_T	Total power Dissipation	@ $T_{mb} = 25^\circ\text{C}$	40
T_J	Junction Temperature		150
T_{Stg}	Storage Temperature		-65 to +150

THERMAL CHARACTERISTICS

Symbol	Ratings	Value	Unit
R_{thJ-mb}	Thermal Resistance, Junction to mouting base	3.12	K/W
R_{thJ-a}	Thermal Resistance, Junction to ambient in free air	100	K/W

NPN BD683

PNP BD684

ELECTRICAL CHARACTERISTICS

TC=25°C unless otherwise noted

Symbol	Ratings	Test Condition(s)	Min	Typ	Max	Unit
I_{CBO}	Collector cut-off current	$I_E=0, V_{CB}=V_{CEOMAX}=120\text{ V}$	-	-	0,2	mA
		$I_E=0, V_{CB}=1/2V_{CBOMAX}=70\text{ V}, T_J=150^\circ\text{C}$	-	-	1	
I_{CEO}	Collector cut-off current	$I_B=0, V_{CE}=1/2V_{CEOMAX}=60\text{ V}$	-	-	0,2	mA
I_{EBO}	Emitter cut-off current	$I_C=0, V_{EB}=5\text{ V}$	-	-	5	mA
$V_{CE(SAT)}$	Collector-Emmitter saturation Voltage	$I_C=1.5\text{ A}, I_B=6\text{ mA}$	-	-	2,5	V
h_{FE}	DC Current Gain	$V_{CE}=3\text{ V}, I_C=500\text{ mA}$	-	2200	-	
		$V_{CE}=3\text{ V}, I_C=1,5\text{ A}$	750	-	-	
		$V_{CE}=3\text{ V}, I_C=4\text{ A}$	-	1500	-	
V_{BE}	Base-Emmitter Voltage(1&2)	$V_{CE}=3\text{ V}, I_C=1,5\text{ A}$	-	-	2,5	V
h_{fe}	Small signal current gain	$V_{CE}=3\text{ V}, I_C=1,5\text{ A}, f=1\text{ MHz}$	10	-	-	
f_{hfe}	Ut-off frequency	$V_{CE}=3\text{ V}, I_C=1,5\text{ A}$	-	60	-	kHz
V_F	Diode forward voltage	$I_F=1,5\text{ A}$				
$I_{(SB)}$	Second-breakdown collector current	$V_{CE}=50\text{ V}, t_p=20\text{ ms}, \text{non rep.}, \text{without heatsink}$	0,8	-	-	A
t_{on}	Turn-on time	$I_{con}=1,5\text{ A}, I_{bon}=-I_{boff}=6\text{ mA}, V_{CC}=30\text{ V}$	-	0,8	2	μs
t_{off}	Turn-off time		-	4,5	8	

1. Measured under pulse conditions : $t_p < 300\mu\text{s}, \delta < 2\%$.
2. V_{BE} decreases by about 3,6 mV/K with increasing temperature.

MECHANICAL DATA CASE TO-126

	DIMENSIONS			
	mm		inches	
	min	max	min	max
A	7.4	7.8	0.295	0.307
B	10.5	10.8	0.413	0.425
C	2.4	2.7	0.094	0.106
D	0.7	0.9	0.027	0.035
E	2.2 typ.		0.087 typ.	
F	0.49	0.75	0.019	0.029
G	4.4 typ.		0.173 typ.	
H	2.54 typ.		0.100 typ.	
L	15.7 typ.		0.618 typ.	
M	1.2 typ.		0.047 typ.	
N	3.8 typ.		0.149 typ.	
P	3.0	3.2	0.118	0.126

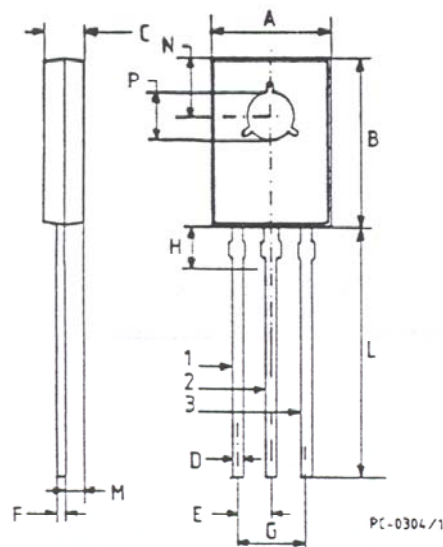

Pin 1 :	Emitter
Pin 2 :	Collector
Pin 3 :	Base

Information furnished is believed to be accurate and reliable. However, CS assumes no responsibility for the consequences of use of such information nor for errors that could appear.
Data are subject to change without notice.