

DATA SHEET

BLV90 UHF power transistor

Product specification

February 1996

UHF power transistor

BLV90

DESCRIPTION

NPN silicon planar epitaxial transistor designed for use in mobile radio transmitters in the 900 MHz band.

FEATURES

- diffused emitter-ballasting resistors for an optimum temperature profile.
- gold metallization ensures excellent reliability.
- the device can be applied at rated output power without an external heatsink when it is mounted on a printed-circuit board (see Fig.6).

The transistor has a 4-lead envelope with a ceramic cap (SOT-172D). All leads are isolated from the mounting base.

QUICK REFERENCE DATA

RF performance at $T_a = 25\text{ }^\circ\text{C}$ in a common-emitter class-B circuit.⁽¹⁾

MODE OF OPERATION	V_{CE} V	f MHz	P_L W	G_p dB	η_c %
Narrow band; CW	12.5	900	1	> 7.5	> 50
	9.6	900	1	typ. 7.0	typ. 57

Note

1. Device mounted on a printed-circuit board (see Fig.6).

PIN CONFIGURATION

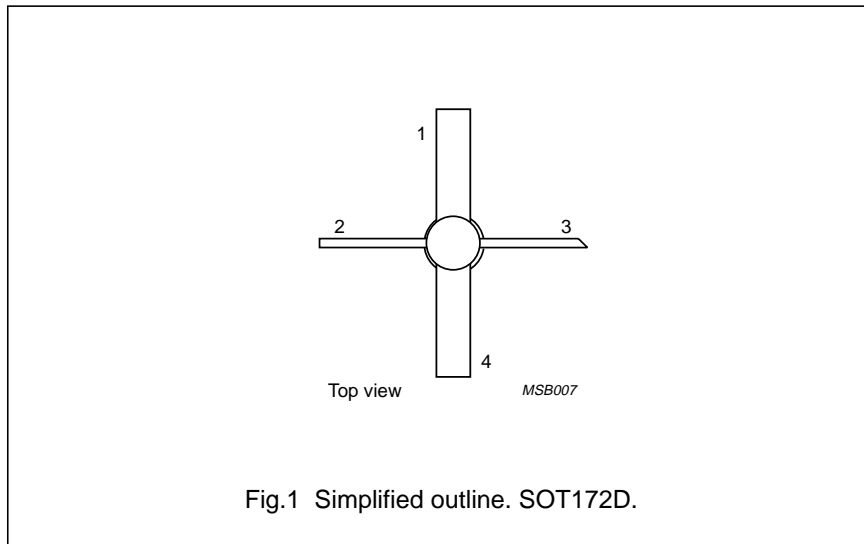

PINNING - SOT172D.

PIN	DESCRIPTION
1	emitter
2	base
3	collector
4	emitter

PRODUCT SAFETY This device incorporates beryllium oxide, the dust of which is toxic. The device is entirely safe provided that the BeO disc is not damaged.

UHF power transistor

BLV90

RATINGS

Limiting values in accordance with the Absolute Maximum System (IEC 134)

Collector-base voltage (open emitter)	V_{CBO}	max.	36 V
Collector-emitter voltage (open base)	V_{CEO}	max.	16 V
Emitter-base voltage (open collector)	V_{EBO}	max.	3 V
Collector current			
DC or average	$I_C; I_{C(AV)}$	max.	0.2 A
(peak value); $f > 1$ MHz	I_{CM}	max.	0.6 A
Total power dissipation			
$f > 1$ MHz; $T_{mb} < 105$ °C	$P_{tot(rf)}$	max.	3.5 W
Storage temperature	T_{stg}		-65 to + 150 °C
Operating junction temperature	T_j	max.	200 °C

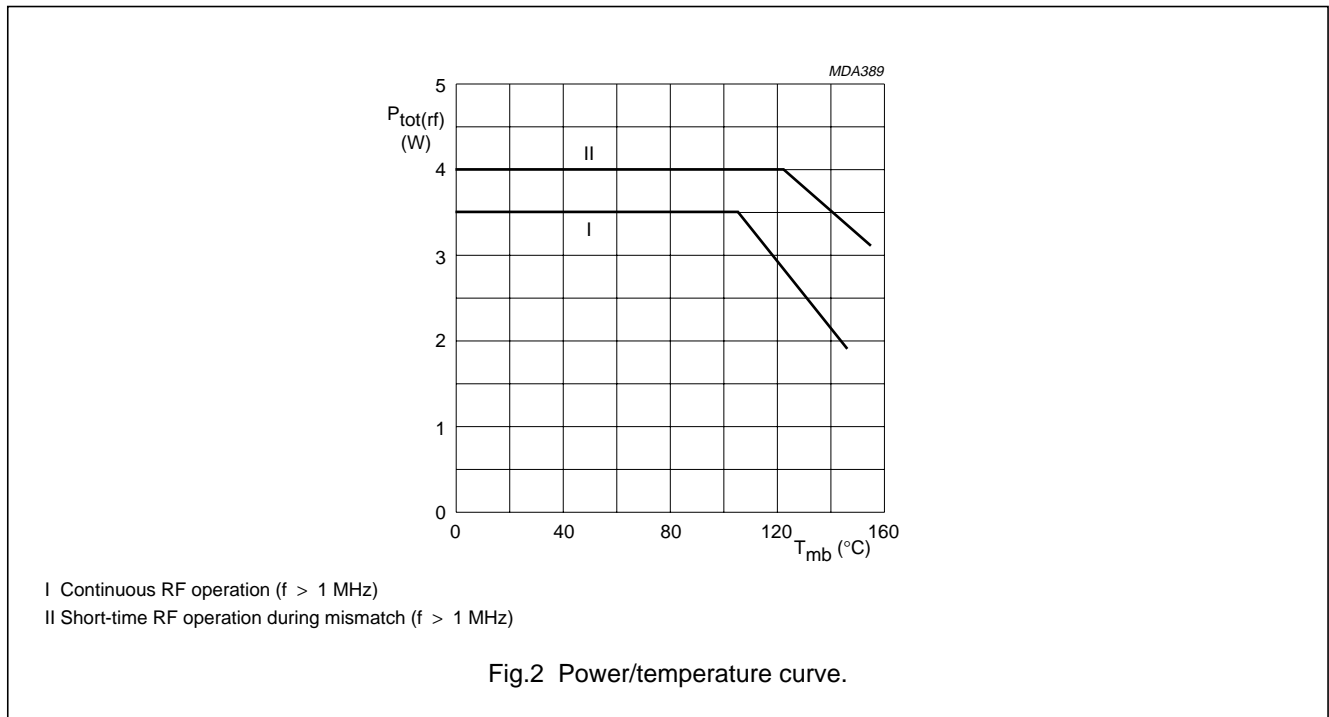

THERMAL RESISTANCE

Dissipation = 2.25 W

From junction to ambient⁽¹⁾ ($f > 1$ MHz)

$T_a = 25$ °C

$R_{th\ j-a}$ (RF) max. 60 K/W

From junction to mounting base

$T_{mb} = 25$ °C ($f > 1$ MHz)

$R_{th\ j-mb}$ (RF) max. 19 K/W

Note

1. Device mounted on a printed-circuit board (see Fig.6).

UHF power transistor

BLV90

CHARACTERISTICS

$T_j = 25\text{ }^\circ\text{C}$ unless otherwise specified

Collector-base breakdown voltage

open emitter; $I_C = 2.5\text{ mA}$

$V_{(BR)CBO} > 36\text{ V}$

Collector-emitter breakdown voltage

open base; $I_C = 10\text{ mA}$

$V_{(BR)CEO} > 16\text{ V}$

Emitter-base breakdown voltage

open collector; $I_E = 0.5\text{ mA}$

$V_{(BR)EBO} > 3\text{ V}$

Collector cut-off current

$V_{BE} = 0; V_{CE} = 16\text{ V}$

$I_{CES} < 1\text{ mA}$

Second breakdown energy

$L = 25\text{ mH}; f = 50\text{ Hz}; R_{BE} = 10\text{ }\Omega$

$E_{SBR} > 0.3\text{ mJ}$

D.C. current gain

$I_C = 0.15\text{ A}; V_{CE} = 10\text{ V}$

$h_{FE} > 25$

Collector capacitance at $f = 1\text{ MHz}$

$I_E = i_e = 0; V_{CB} = 12.5\text{ V}$

C_c typ. 1.8 pF

Feedback capacitance at $f = 1\text{ MHz}$

$I_C = 0; V_{CE} = 12.5\text{ V}$

C_{re} typ. 1.0 pF

Collector-mounting base capacitance

C_{c-mb} typ. 0.5 pF

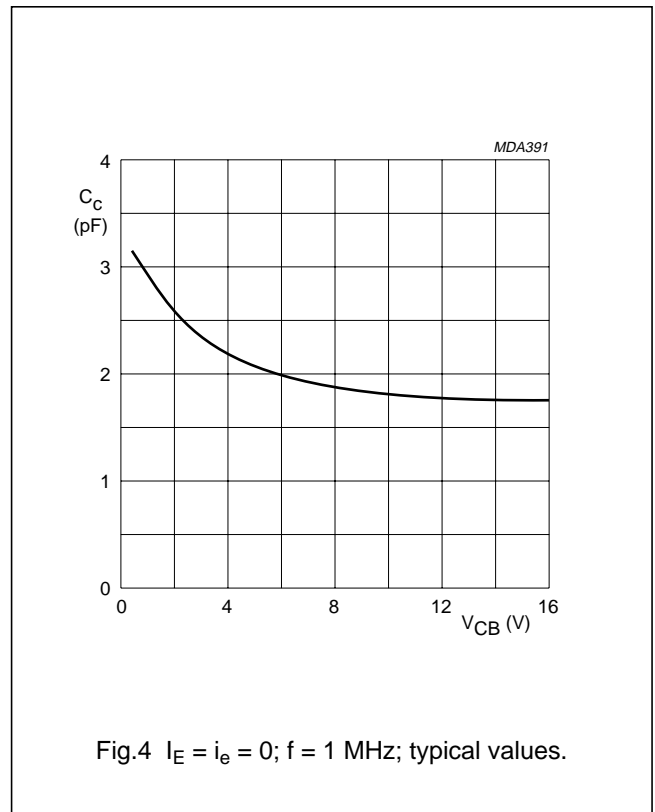
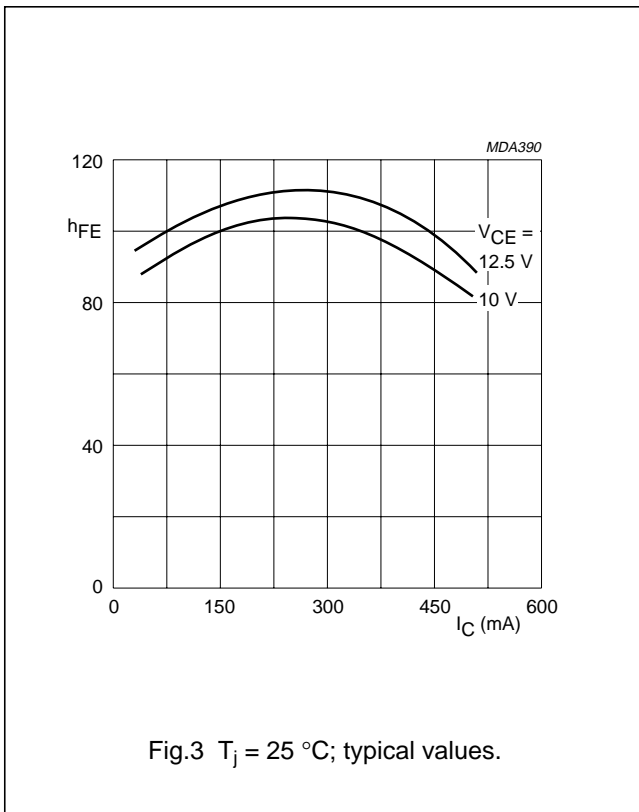

UHF power transistor

BLV90

APPLICATION INFORMATION

RF performance in CW operation (common-emitter circuit, class-B): $f = 900 \text{ MHz}$; $T_a = 25 \text{ }^\circ\text{C}$

MODE OF OPERATION	V_{CE} V	P_L W	G_p dB	η_c %
narrow band; CW	12.5	1	> 7.5 typ. 9.0	> 50 typ. 60
	9.6	1	typ. 7.0	typ. 57

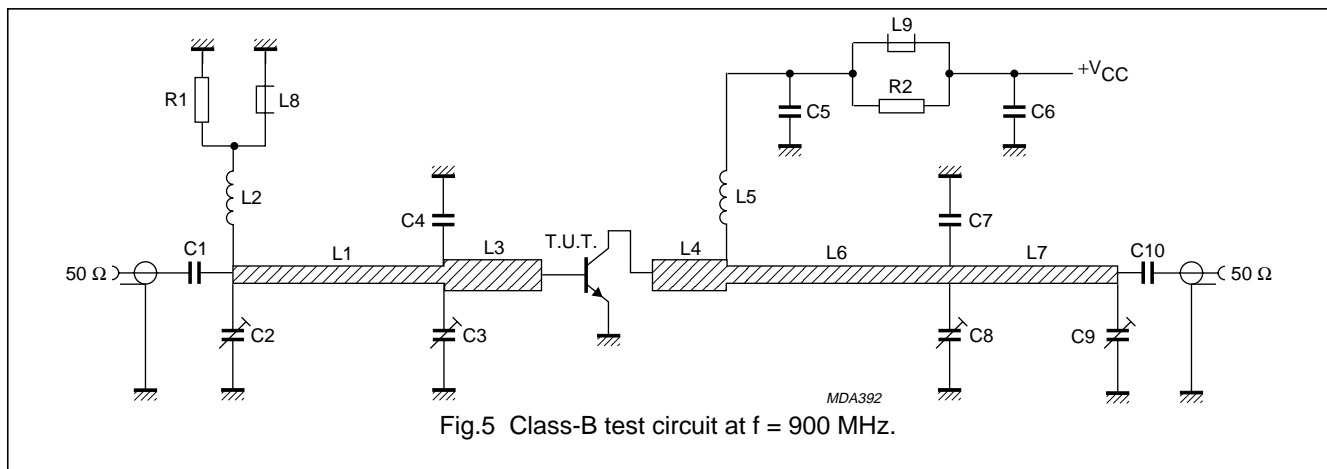

List of components:

- C1 = C10 = 33 pF multilayer ceramic chip capacitor
- C2 = C9 = 1.4 to 5.5 pF film dielectric trimmer (cat. no. 2222 809 09001)
- C3 = 2 to 9 pF film dielectric trimmer (cat. no. 2222 809 09002)
- C4 = 5.6 pF multilayer ceramic chip capacitor⁽¹⁾
- C5 = 10 pF multilayer ceramic chip capacitor
- C6 = 330 pF multilayer ceramic chip capacitor
- C7 = 3.9 pF multilayer ceramic chip capacitor⁽¹⁾
- C8 = 1.2 to 3.5 pF film dielectric trimmer (cat. no. 2222 809 05001)
- L1 = L7 = 50 Ω stripline (30.8 mm \times 2.4 mm)
- L2 = 60 nH; 4 turns closely wound enamelled Cu wire (0.4 mm); int. dia. 3 mm; leads 2 \times 5 mm
- L3 = 38 Ω stripline (16.0 mm \times 3.5 mm)
- L4 = 38 Ω stripline (11.0 mm \times 3.5 mm)
- L5 = 280 nH; 15 turns closely wound enamelled Cu wire (0.4 mm); int. dia. 3 mm; leads 2 \times 5 mm
- L6 = 50 Ω stripline (41.2 mm \times 2.4 mm)
- L8 = L9 = Ferroxcube wideband HF choke, grade 3B (cat. no. 4312 020 36642)
- R1 = R2 = 10 $\Omega \pm 5\%$; 0.25 W metal film resistor

L1, L3, L4, L6 and L7 are striplines on a double Cu-clad printed-circuit board with P.T.F.E. fibre-glass dielectric ($\epsilon_r = 2.2$); thickness $\frac{1}{32}$ inch; thickness of copper-sheet 2 \times 35 μm .

Notes

1. American Technical Ceramics capacitor type 100A or capacitor of same quality.
2. Device mounted on a printed-circuit board (see Fig.6).

UHF power transistor

BLV90

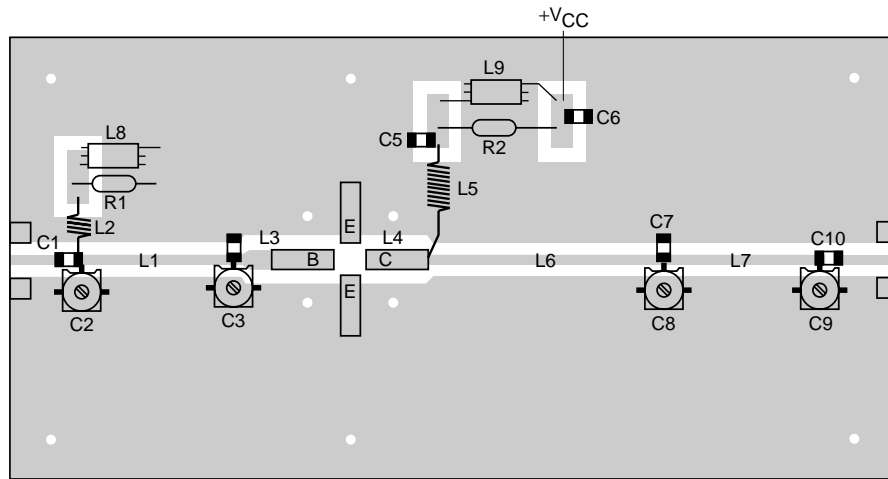
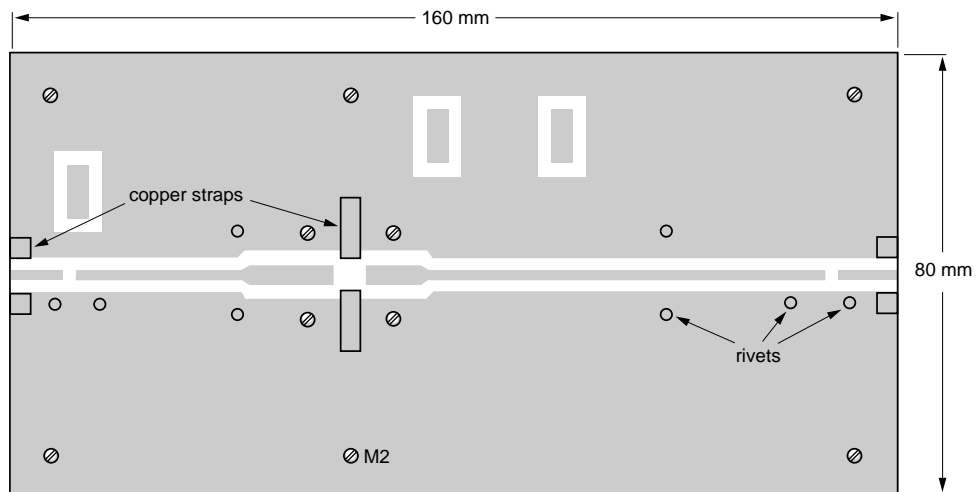

MDA393

The circuit and the components are on one side of the P.T.F.E. fibre-glass board; the other side is unetched copper serving as groundplane. Earth connections are made by hollow rivets and also by fixing-screws and copper straps around the board and under the emitters to provide a direct contact between the copper on the component side and the groundplane.

Fig.6 Printed-circuit board and component lay-out for 900 MHz class-B test circuit.

UHF power transistor

BLV90

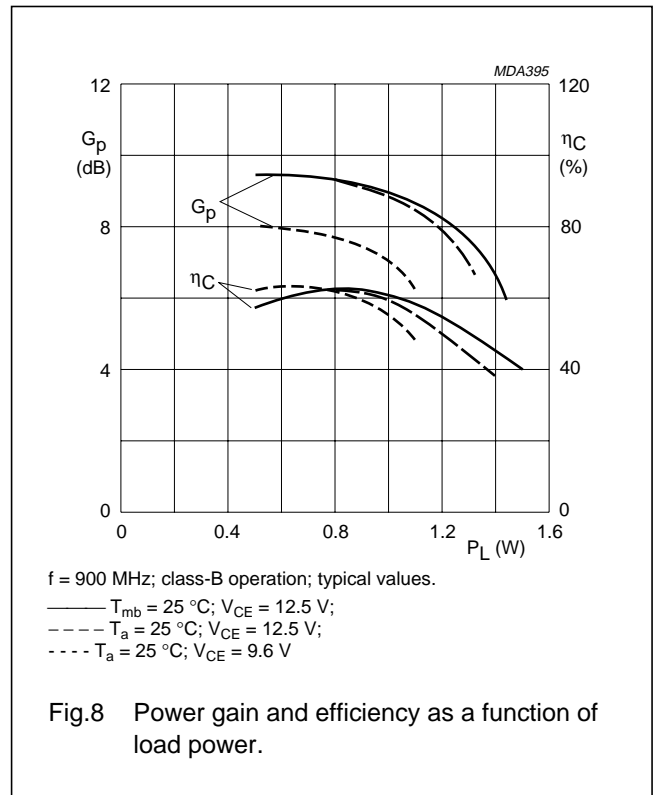
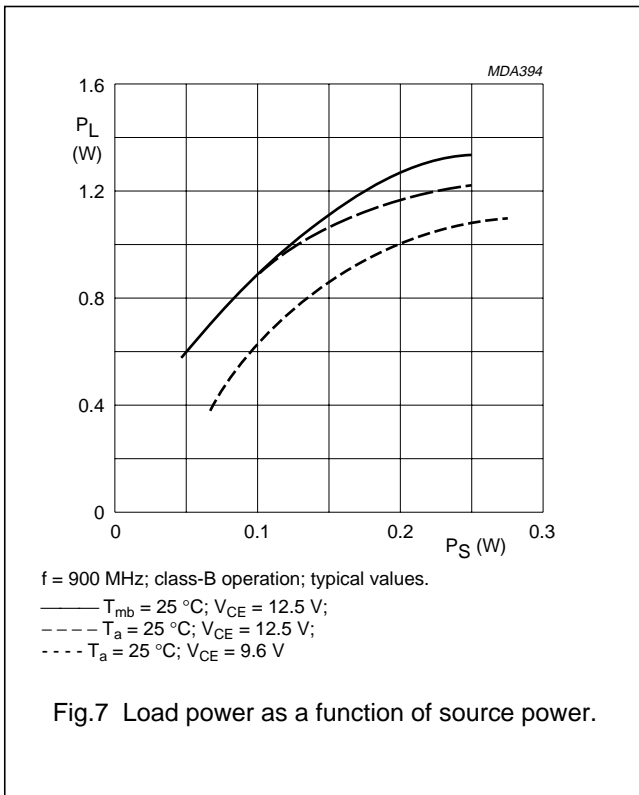

RUGGEDNESS

The device is capable to withstand a full load mismatch (VSWR = 50; all phases) at rated load power up to a supply voltage of 15.5 V at $T_a = 25$ °C. Device mounted on a printed-circuit board (see Fig.6).

UHF power transistor

BLV90

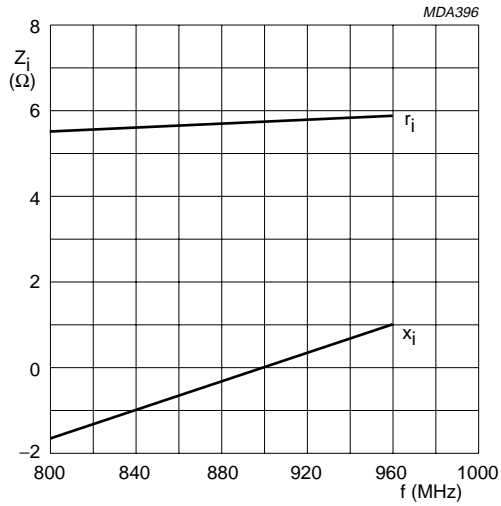

$V_{CE} = 12.5$ V; $P_L = 1$ W; $f = 800 - 960$ MHz;
 $T_{mb} = 25$ °C; class-B operation; typical values.

Fig.9 Input impedance (series components).

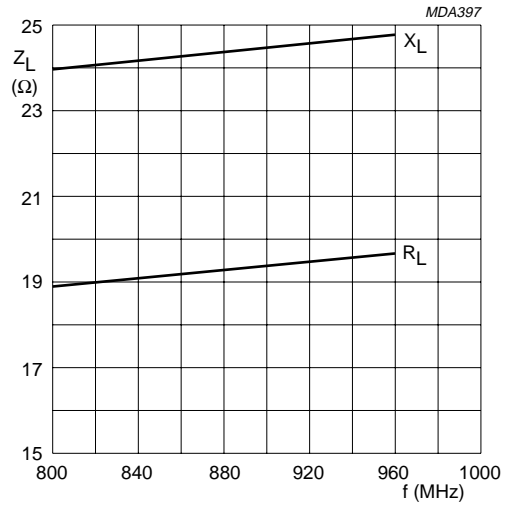

$V_{CE} = 12.5$ V; $P_L = 1$ W; $f = 800 - 960$ MHz;
 $T_{mb} = 25$ °C; class-B operation; typical values.

Fig.10 Load impedance (series components).

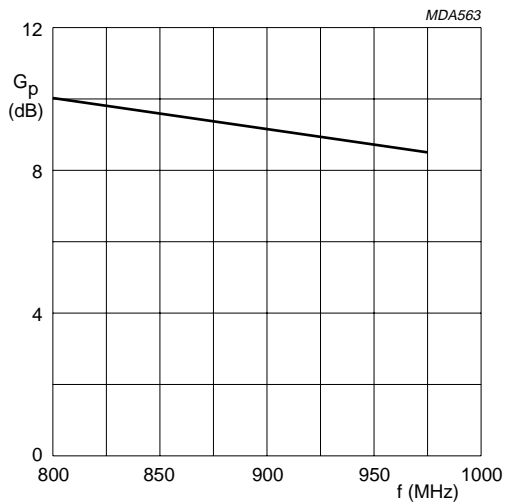

$V_{CE} = 12.5$ V; $P_L = 1$ W; $f = 800 - 960$ MHz;
 $T_{mb} = 25$ °C; class-B operation; typical values.

Fig.11 Power gain as a function of frequency.

UHF power transistor

BLV90

PACKAGE OUTLINE

Studless ceramic package; 4 leads

SOT172D

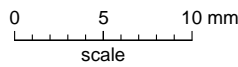
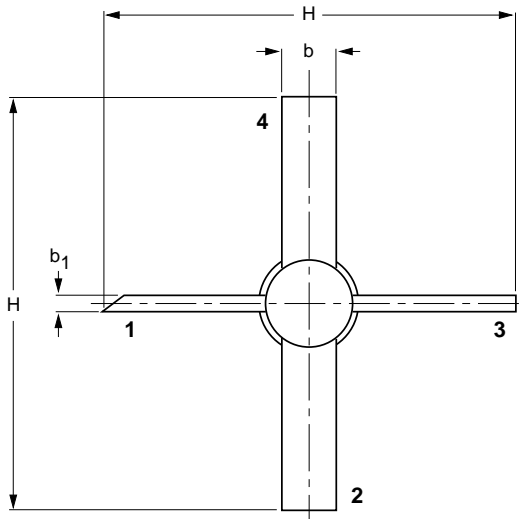
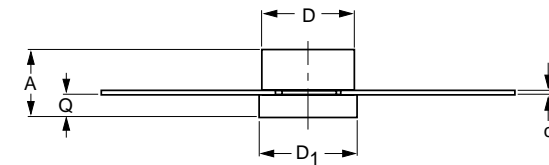

DIMENSIONS (millimetre dimensions are derived from the original inch dimensions)

UNIT	A	b	b ₁	c	D	D ₁	H	Q
mm	3.71 2.89	3.31 3.04	0.89 0.63	0.16 0.10	5.20 4.95	5.33 5.08	26.17 24.63	1.15 0.88
inches	0.146 0.114	0.13 0.12	0.035 0.025	0.006 0.004	0.205 0.195	0.210 0.200	1.03 0.97	0.045 0.035

OUTLINE VERSION	REFERENCES				EUROPEAN PROJECTION	ISSUE DATE
	IEC	JEDEC	EIAJ			
SOT172D						97-06-28

UHF power transistor

BLV90

DEFINITIONS

Data Sheet Status	
Objective specification	This data sheet contains target or goal specifications for product development.
Preliminary specification	This data sheet contains preliminary data; supplementary data may be published later.
Product specification	This data sheet contains final product specifications.
Limiting values	
Limiting values given are in accordance with the Absolute Maximum Rating System (IEC 134). Stress above one or more of the limiting values may cause permanent damage to the device. These are stress ratings only and operation of the device at these or at any other conditions above those given in the Characteristics sections of the specification is not implied. Exposure to limiting values for extended periods may affect device reliability.	
Application information	
Where application information is given, it is advisory and does not form part of the specification.	

LIFE SUPPORT APPLICATIONS

These products are not designed for use in life support appliances, devices, or systems where malfunction of these products can reasonably be expected to result in personal injury. Philips customers using or selling these products for use in such applications do so at their own risk and agree to fully indemnify Philips for any damages resulting from such improper use or sale.