

SONY

CXA1611M/N/P

FM/AM Radio

Description

CXA1611M/N/P is an IC designed for use in FM/AM radios, integrating all necessary functions from the front end detector stage of a radio.

Features

- Wide application range as it contains functions from the front end to detector stage.
- Operable for wide range of power supply voltages. (Vcc=2 to 9V)
- Low current consumption. (For FM, I_D=6.0mA, for AM, I_D=4.0mA, at Vcc=6V)
- Self-contained LED drive circuit for tuning.
- Self-contained FM band signal output circuit.
- Variable capacitance diode for FM AFC.
- Low distortion factor (0.1% Typ.) for FM detection output.
- AM IF output pin which can be adapted for the AM stereo.
- Needs few peripheral parts. Due to its small size, a high density packaging design is possible.

Structure

Bipolar silicon monolithic IC

Absolute Maximum Ratings (Ta=25°C)

• Supply voltage	Vcc	14	V
• Operating temperature	To _{pr}	-20 to +75	°C
• Storage temperature	T _{stg}	-55 to +150	°C
• Allowable power dissipation	P _D	800 (DIP)	mW
		500 (SOP)	mW
		250 (SSOP)	mW

Recommended Operating Condition

Supply voltage	Vcc	2 to 9	V
----------------	-----	--------	---



Sony reserves the right to change products and specifications without prior notice. This information does not convey any license by any implication or otherwise under any patents or other right. Application circuits shown, if any, are typical examples illustrating the operation of the devices. Sony cannot assume responsibility for any problems arising out of the use of these circuits.



Block Diagram

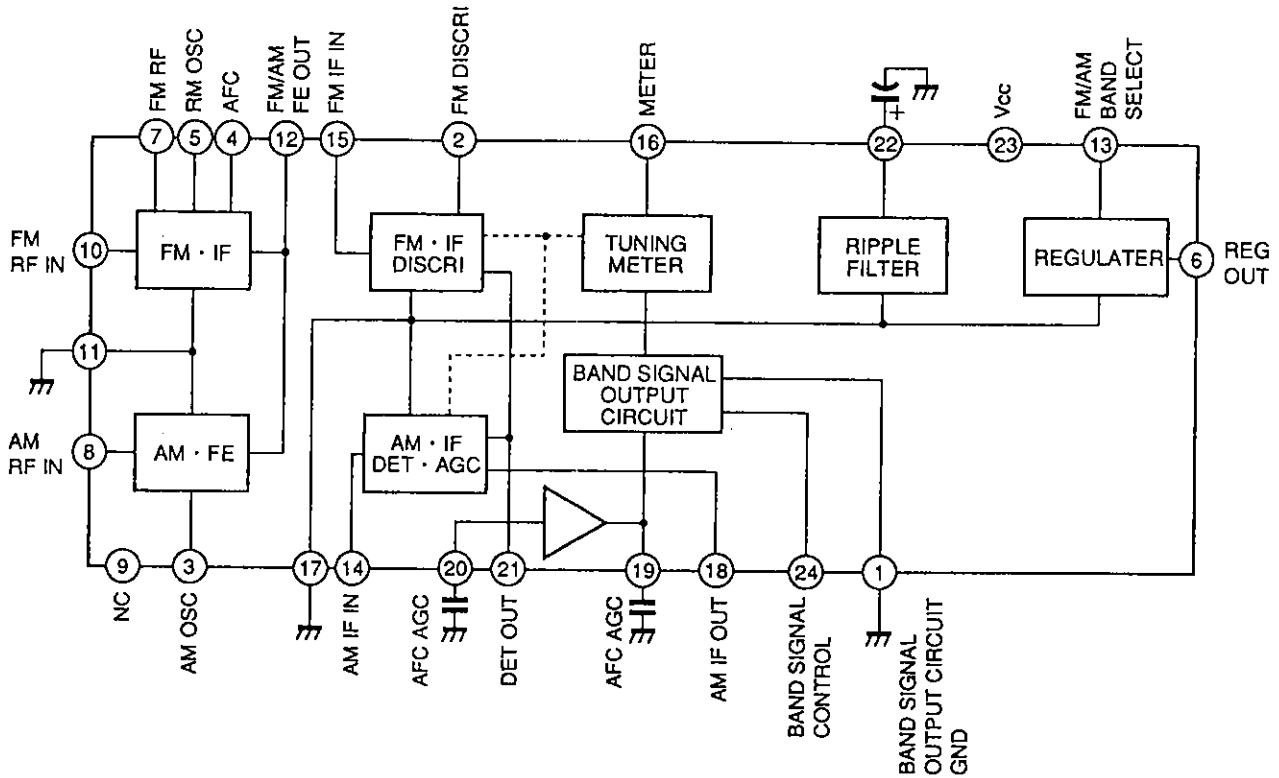

Pin Configuration (Top View)

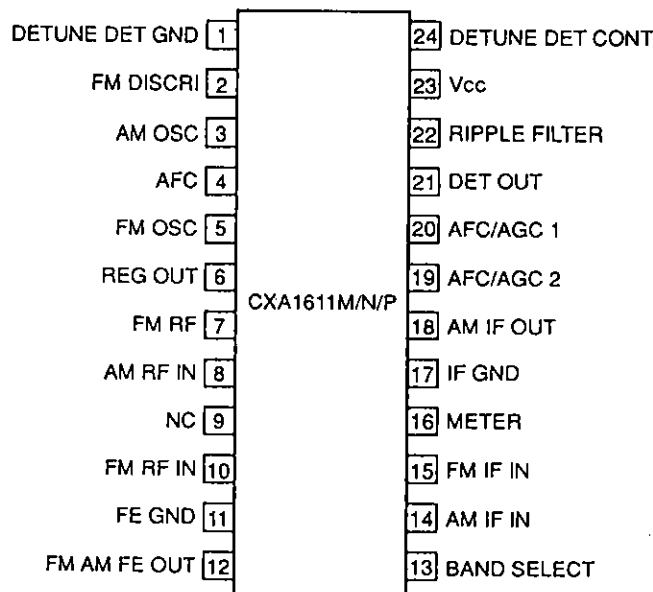

Pin Description

Pin No.	Symbol	Description
1	GND	Ground for band signal output
2	FM DISCRI	Discriminator pin; to be connected to FM discriminator
3	AM OSC	AM local oscillator circuit
4	AFC	AFC input pin
5	FM OSC	FM local oscillator
6	REG OUT	Regulator; 1.25V (typ.)
7	FM RF	FM RF input; connected to RF tank circuit
8	AM RF IN	AM RF input; connected to BAR ANT
9	NC	
10	FM RF IN	FM RF amplifier circuit; FM RF input
11	GND	Ground for front end
12	FM/AM FE OUT	IF output circuit for AM and FM; connected to AM and FM IF filters
13	BAND SELECT	Pin of FM and AM band switch; AM for "GND" and FM for "OPEN"
14	AM IF IN	Input stage of AM IF
15	FM IF IN	The first stage of FM IF amplifier circuit
16	METER	Meter drive circuit
17	IF GND	AM/FM IF stage; ground for detector stage
18	AM IF OUT	AM IF output; emitter output
19	AFC/AGC 2	AFC pin for W band; to adjust the time constant (using a capacitor of external circuit) with AM
20	AFC/AGC 1	AFC pin for J band; to adjust the time constant (using a capacitor in external circuit) with AM
21	DET OUT	Pin of the detector output; impedance; approx. 5k Ω
22	RIPPLE	The ripple filter; the hum suppression level of approx. 34.5dB can be obtained by connecting a 10 μ F capacitor
23	Vcc	IC power supply
24	BAND SIGNAL OUTPUT CONTROL	Band signal output amplitude is adjusted by connecting an outside resistor

(Ta=25°C, See the Electrical Characteristics Test Circuit)

Electrical Characteristics

No.	Test Item	Symbol	Switch Position										Bias Condition			Test Point	Output Waveform and Method of Test	Min.	Typ.	Max.	Unit				
			S1	S2	S3	S4	S5	S6	S7	S8	S9	VIN1	VIN2	VIN3	VIN4										
1	Circuit current (1)	ID1	OFF	B	OFF	B	A	A	ON	OFF	OFF	OFF	OFF	OFF	OFF	OFF	OFF	OFF	OFF	IB	Short circuit VIN1 through VIN4 when either AM signal or FM signal is not present	1.8	4.0	6.6	mA
2	Circuit current (2)	ID2	OFF	B	OFF	B	B	B	ON	OFF	OFF	OFF	OFF	OFF	OFF	OFF	OFF	OFF	OFF	IB		3.6	6.0	8.25	mA
3	FM front end voltage gain (1)	GV1	ON	A											ON					V0	VIN1=100MHz 40dBμV CW VA=10.7MHz CW	33	39	45	dB
4	FM detector output level (1)	VD1	OFF	B											OFF					V0	VIN3=10.7MHz 90dBμV 1kHz 22.5kHz dev V0=1kHz sin Wave	-25.2	-22.5	-19.0	dBs
5	FM detector output level (2)	ΔVD																		V0	V01 and Vcc=9V; level difference with same value of V01	-4.0	-	+4.0	dB
6	FM IF knee level	VD2																		VIN3	VIN3 level is -3dB with reference to V01	-	25	31	dBμ
7	FM detector output distortion factor (1)	THD1																		V0	VIN3=10.7MHz 90dBμV 1kHz 75kHz dev V0=1kHz sin Wave	-	0.1	1.1	%
8	Deviation of FM IF center frequency	F1																		-	VIN3=10.7MHz 90dBμV CW	-55	0	55	kHz
9	FM meter current (1)	IB1																		IB	VIN3=10.7MHz 60dBμV CW	1.8	3.5	6.05	mA
10	FM band signal output band width	F2												ON						IB	VIN3=10.7MHz 235kHz Confirm IB=0 at 90dBμV	±67.5	±110	±170.5	kHz
11	AM front end voltage gain (2)	GV2	ON	ON											OFF					V0	VIN2=1660kHz 60dBμV CW DB=455kHz CW	19	24	28	dB
12	AM IF voltage gain (3)	GV3	OFF	OFF	OFF	OFF	OFF	OFF	OFF	OFF	OFF	OFF	OFF	OFF	OFF	OFF	OFF	OFF	VIN4	Level of VIN4 at V0=-34dBs	17	23	28	dBμ	
13	AM IF voltage gain (4)	ΔGV																		VIN4	Vcc=2V; level difference with same condition as GV3	-4	0	3	dB
14	AM detector output level (3)	VD3																		V0	VIN4=455kHz 85dBμV 1kHz 30% MOD V0=1kHz sin Wave	-25.5	-22.5	-19.0	dBs
15	AM meter current (2)	IB2																		IB	VIN4=455kHz 85dBμV CW	1.62	3.0	5.5	mA
16	AM IF output level	VE																		VE	VIN4=455kHz 85dBμV CW VE=455kHz CW	72	100	132	mV
17	AM detector output distortion factor (2)	THD2	ON	ON											ON					V0	VIN2=95dBμV 1660kHz 1kHz 30% MOD V0=1kHz sin Wave Vcc=7.8V	-	0.6	1.1	%

Standard Circuit Design Data

NO.	Symbol	Voltage (V)*				Equivalent circuit
		Vcc=3V		Vcc=6V		
		FM	AM	FM	AM	
1	GND	—	—	—	—	—
2	FM DISCRI	2.18	2.70	3.08	3.60	
3	AM OSC	1.25	1.25	1.25	1.25	
4	AFC	1.25	1.15	1.25	1.15	
6	REG OUT	1.25	1.25	1.25	1.25	
5	FM OSC	1.25	1.25	1.25	1.25	
7	FM RF	1.25	1.25	1.25	1.25	
10	FM RF IN	0.3	0	0.3	0	

* See the DC Voltage Test Circuit.
Values are typical values.

NO.	Symbol	Voltage (V)*				Equivalent circuit
		Vcc=3V		Vcc=6V		
		FM	AM	FM	AM	
8	AM RF IN	1.25	1.25	1.25	1.25	
9	NC	—	—	—	—	—
11	GND	—	—	—	—	—
12	FM/AM FE OUT	0.57	0.2	0.8	0.2	
13	BAND SELECT	1.25	0	1.25	0	
15	FM IF IN	1.25	0	1.25	0	
14	AM IF IN	0	0	0	0	
16	METER	1.6	1.6	4.5	4.5	
17	IF GND					
18	AM IF OUT					

NO.	Symbol	Voltage (V)*				Equivalent circuit
		Vcc=3V		Vcc=6V		
		FM	AM	FM	AM	
19	AFC/AGC 2	1.15	1.47	1.15	1.47	
20	AFC/AGC 1	1.47	1.15	1.47	1.15	
21	DET OUT	1.0	1.0	1.0	1.0	
22	RIPPLE	2.7	2.7	4.0	4.0	
23	Vcc	3.0	3.0	6.0	6.0	
24	BAND SIGNAL OUTPUT CONTROL					

Application Circuit

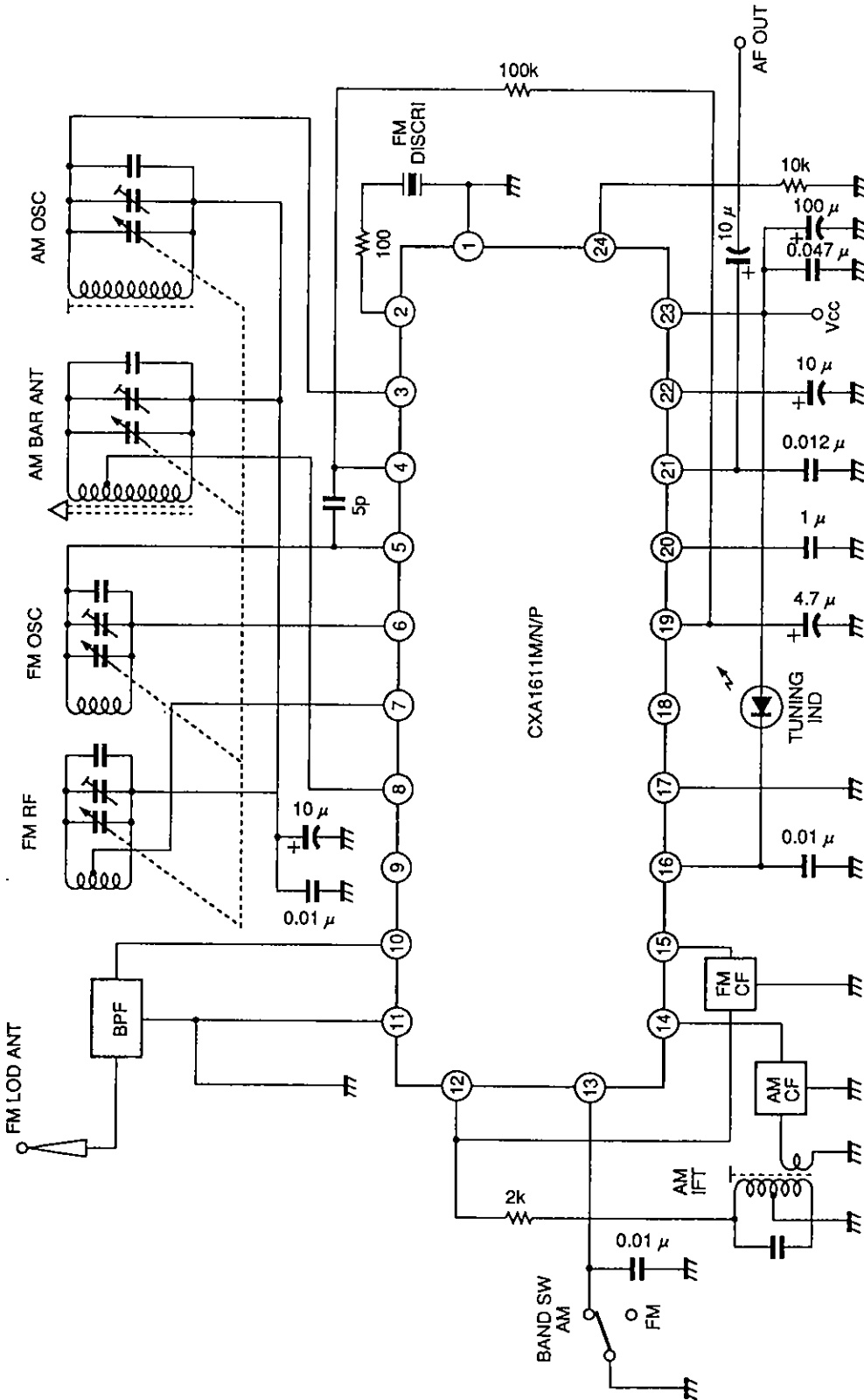

Application circuits shown are typical examples illustrating the operation of the devices. Sony cannot assume responsibility for any problems arising out of the use of these circuits or for any infringement of third party patent and other right due to same.

Example of Representative Characteristics

AM I/O Characteristic

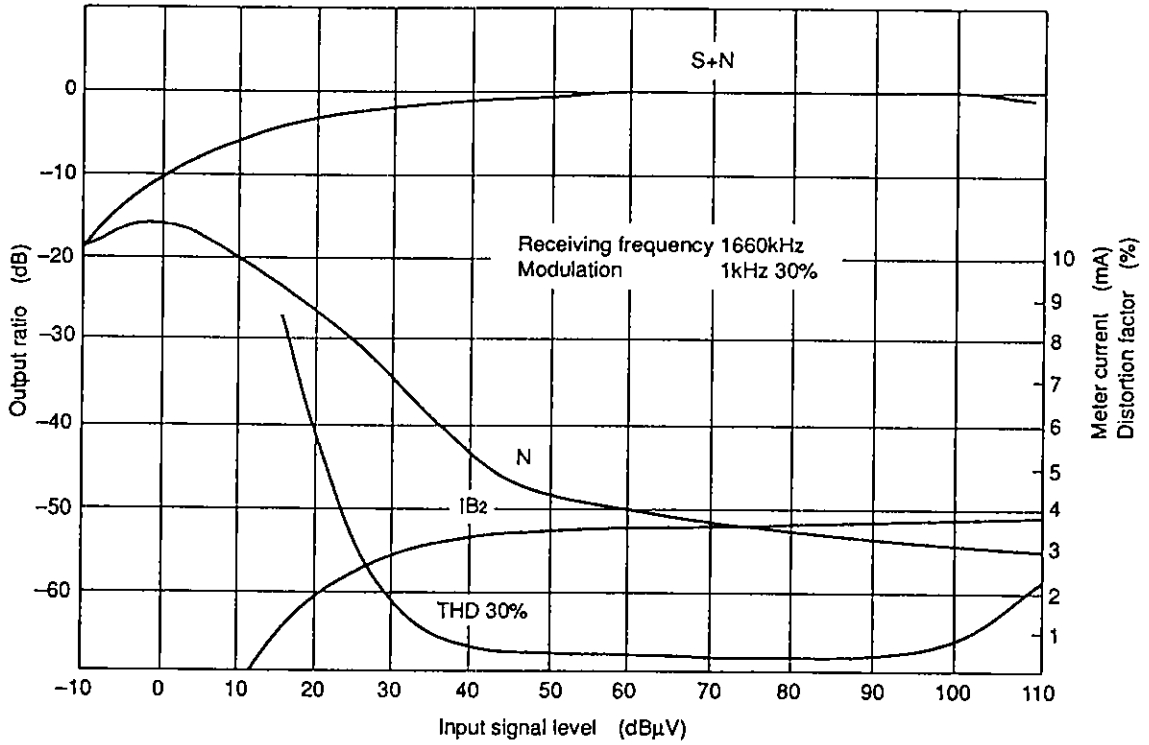

AM I/O Characteristic

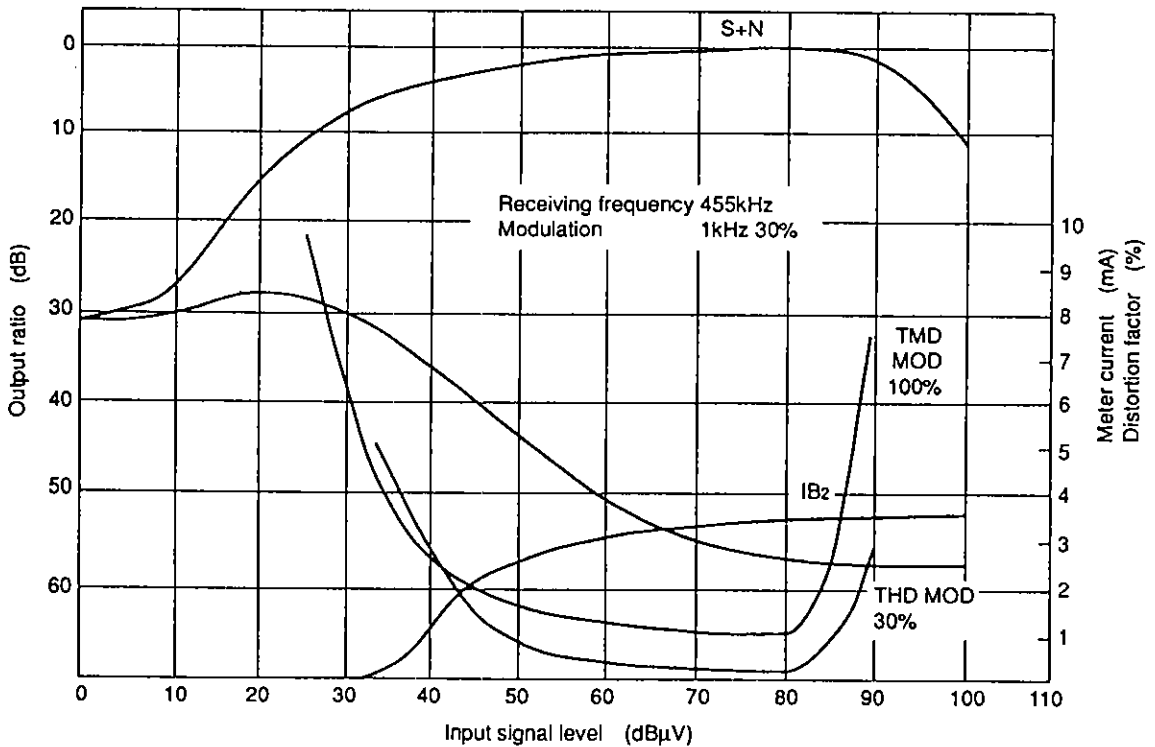

FM I/O Characteristic

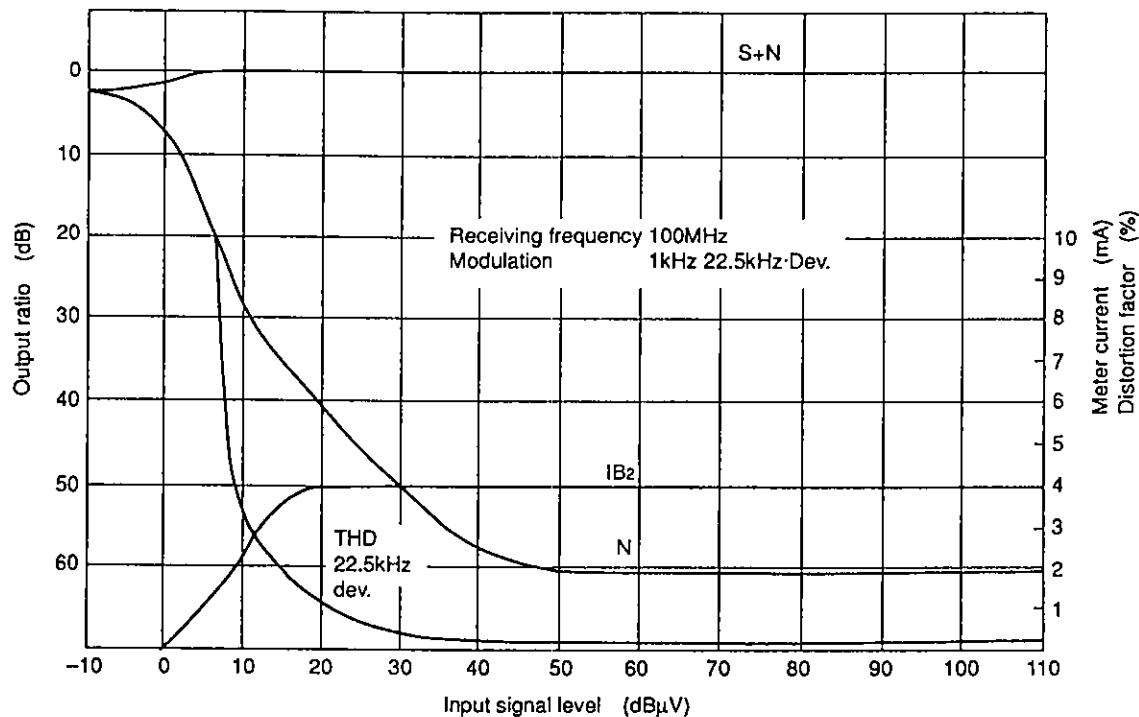

FM I/O Characteristic

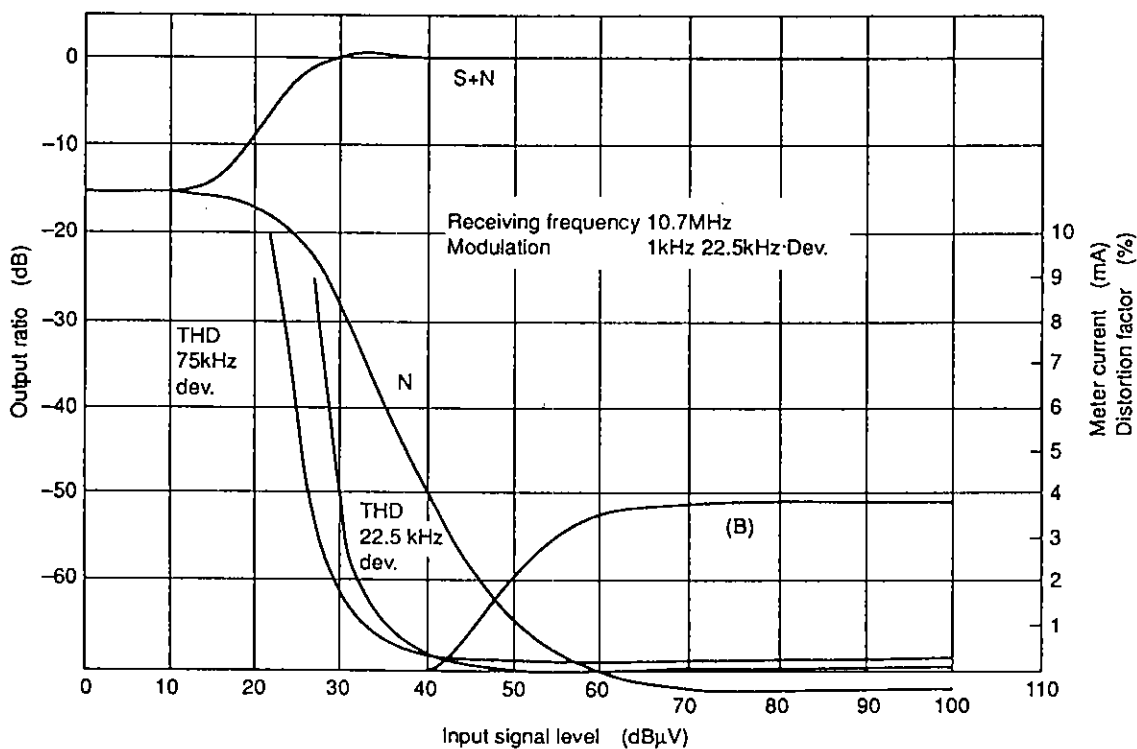

FM Band signal output characteristic (Narrow band)

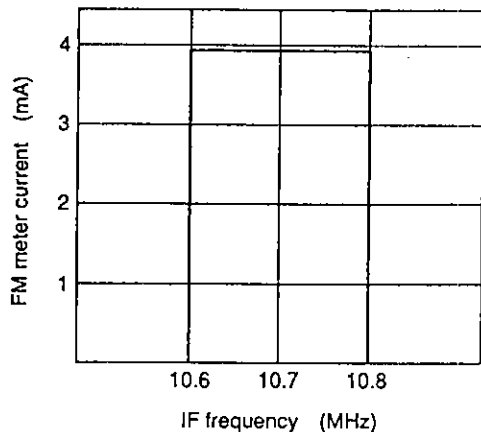

FM Band signal output characteristic (Normal)

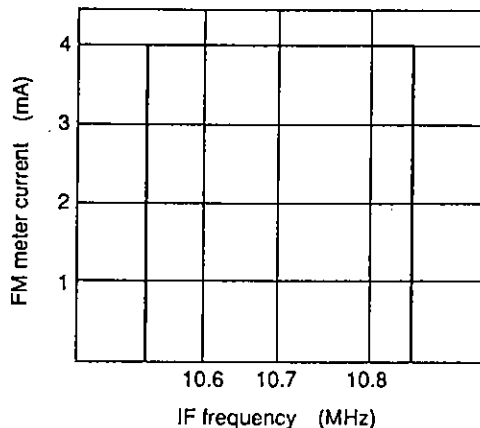

Regulator output vs. Supply voltage characteristics

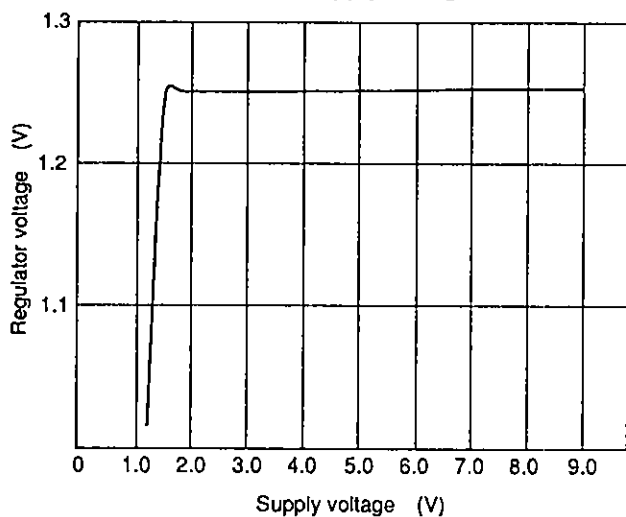

Temperature characteristics of circuit current

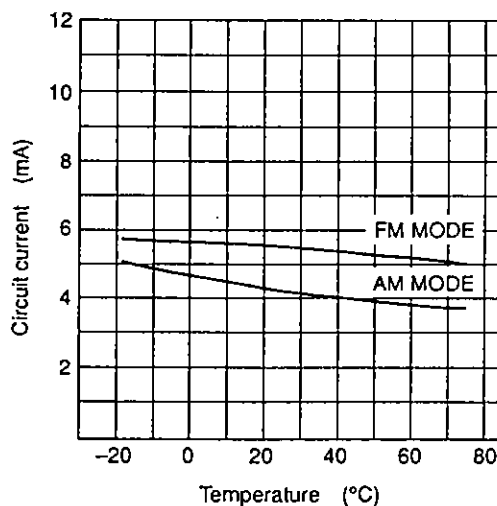

Temperature characteristics of regulator

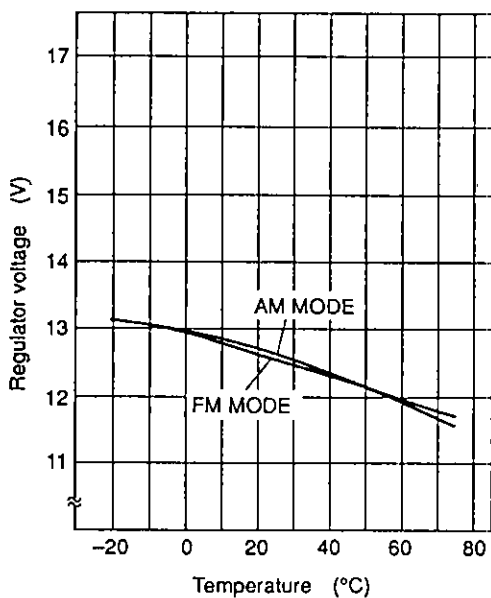

Temperature characteristics of detector output

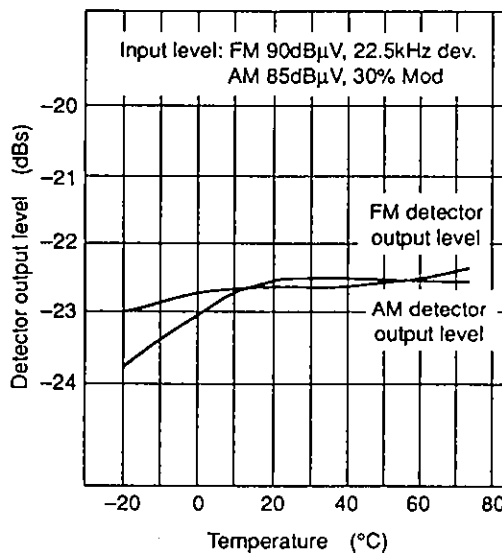

AM IF pin output vs. Input (Overall)

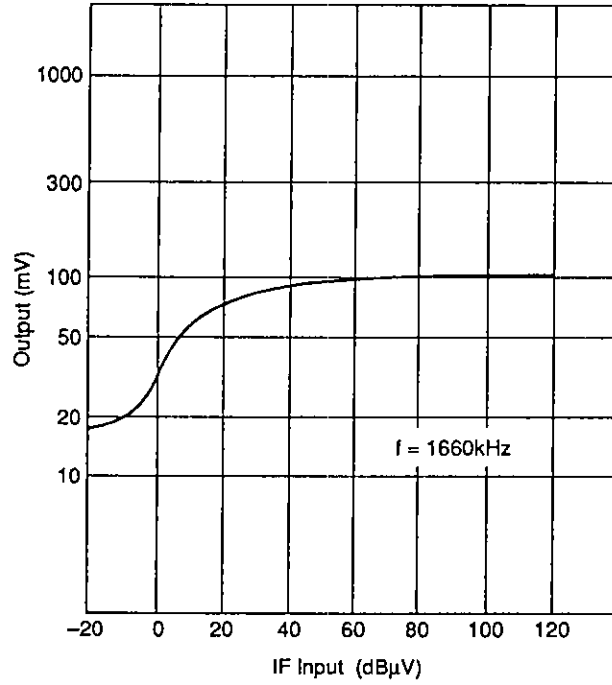

AM IF pin output vs. Input

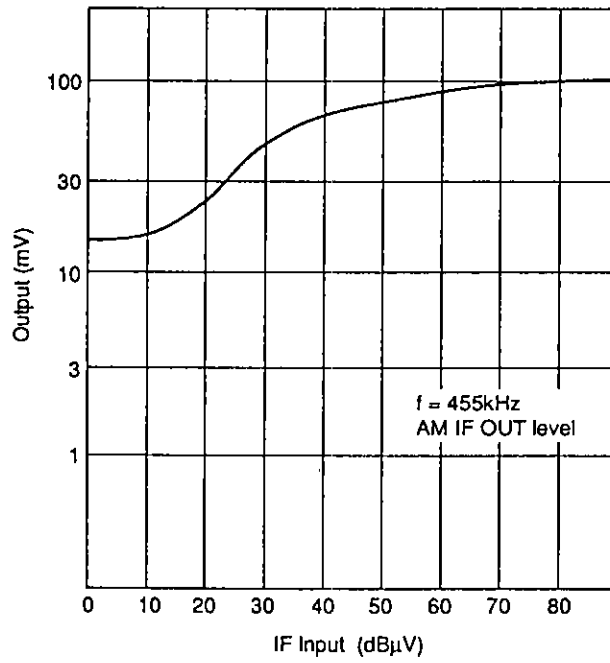

Coil data

AM OSC

WIRE ϕ 0.06mm 2UEW

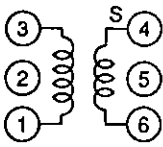

f (kHz)	L (μ H)	Qo	t	
			1 to 3	4 to 6
796	270	125	107	29

Equivalent to L-5K7 H5 R12-1684X.
Mitsumi Electric Co., Ltd. or
7TRS-8441 TOKO Co., Ltd.

AM Bar ANT

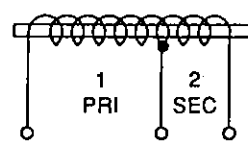

f (kHz)	L (μ H)	1	2
796	650	91t	20t

BPF PFWE8 SOSHIN (88 to 108MHz)

VC PVC2LXT-16L MITUMI }
CF1 CDA10.7MG1 } MURATA } or
CF2 SFU-455B } CF1 BFCFL-455
CF3 SFE10.7MA5 } TOKO

AM IFT

WIRE ϕ 0.07mm UEW

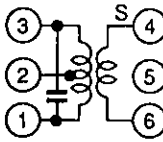

Co (pF)	Qo	t		
		1 to 2	2 to 3	4 to 6
180	90	111	35	7

Equivalent to 21K7 H5 R12-8558A.
Mitsumi Electric Co., Ltd. or
7MC-7789N TOKO Co., Ltd.

FM RF

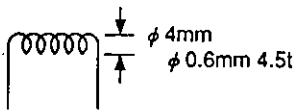

FM OSC

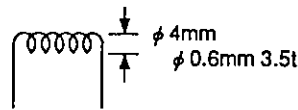

Evaluation Board

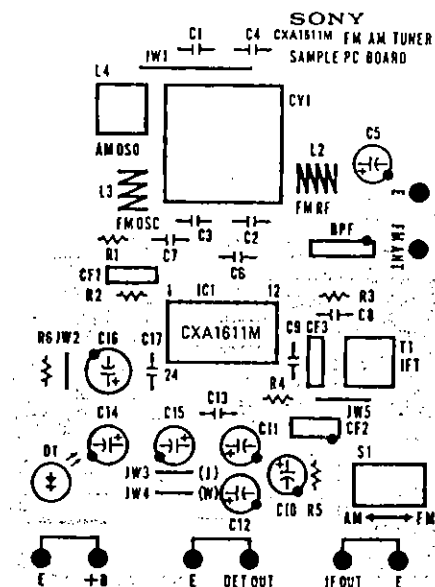
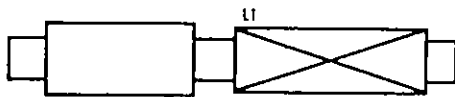

Parts Layout (mounting side)



Pattern

Package Outline Unit : mm

CXA1611M

24PIN SOP (PLASTIC)

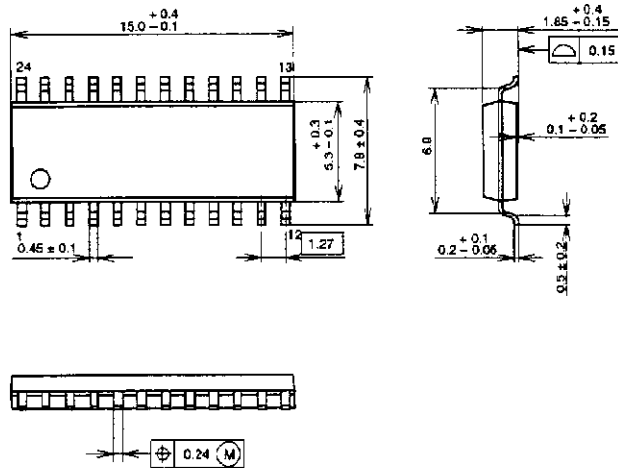

PACKAGE STRUCTURE

SONY CODE	SOP-24P-L01
EIAJ CODE	SOP024-P-0300
JEDEC CODE	

MOLDING COMPOUND	EPOXY RESIN
LEAD TREATMENT	SOLDER PLATING
LEAD MATERIAL	42/COPPER ALLOY
PACKAGE MASS	0.3g

CXA1611N

24PIN SSOP(PLASTIC)

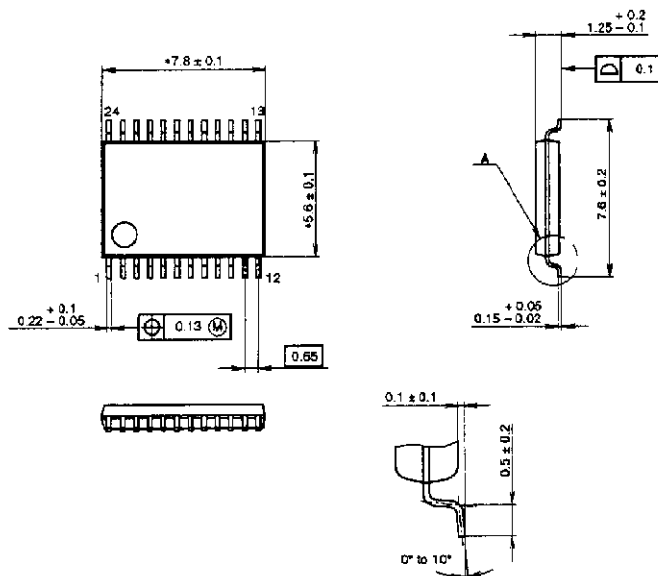

NOTE: Dimensions "*" does not include mold protrusion.

DETAIL A

PACKAGE STRUCTURE

SONY CODE	SSOP-24P-L01
EIAJ CODE	SSOP024-P-0058
JEDEC CODE	

PACKAGE MATERIAL	EPOXY RESIN
LEAD TREATMENT	SOLDER/PALLADIUM PLATING
LEAD MATERIAL	42/COPPER ALLOY
PACKAGE MASS	0.1g

NOTE : PALLADIUM PLATING

This product uses S-PdPPF (Sony Spec.-Palladium Pre-Plated Lead Frame).

CXA1611P

24PIN DIP(PLASTIC)

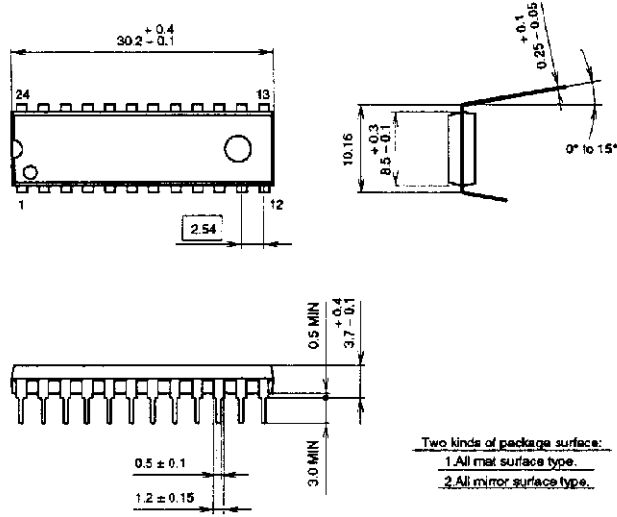

Two kinds of package surface:
 1. All mat surface type.
 2. All mirror surface type.

PACKAGE STRUCTURE

SONY CODE	DIP-24P-01
EIAJ CODE	DIP024-P-0400
JEDEC CODE	_____

PACKAGE MATERIAL	EPOXY RESIN
LEAD TREATMENT	SOLDER PLATING
LEAD MATERIAL	42/COPPER ALLOY
PACKAGE MASS	2.6g