



# TDA7345

## DIGITALLY CONTROLLED AUDIO PROCESSOR WITH SURROUND SOUND MATRIX

- 1 STEREO INPUT
- VOLUME CONTROL IN 1.25dB STEP
- TREBLE AND BASS CONTROL
- THREE SURROUND MODES ARE AVAILABLE:
  - MOVIE, MUSIC AND SIMULATED
- FOUR SPEAKER ATTENUATORS:
  - 4 INDEPENDENT SPEAKERS CONTROL IN 1.25dB STEPS FOR BALANCE FACILITY
  - INDEPENDENT MUTE FUNCTION
- ALL FUNCTIONS PROGRAMMABLE VIA SERIAL BUS

### DESCRIPTION

The TDA7345 is a volume tone (bass and treble) balance (Left/Right) processor for quality audio applications in car radio and Hi-Fi systems. It reproduces surround sound by using phase shifters and a signal matrix. Control of all the functions is accomplished by serial bus. The AC signal setting is obtained by resistor net-



works and switches combined with operational amplifiers.

Thanks to the used BIPOLAR/CMOS Technology, Low Distortion, Low Noise and DC stepping are obtained.

### PIN CONNECTION

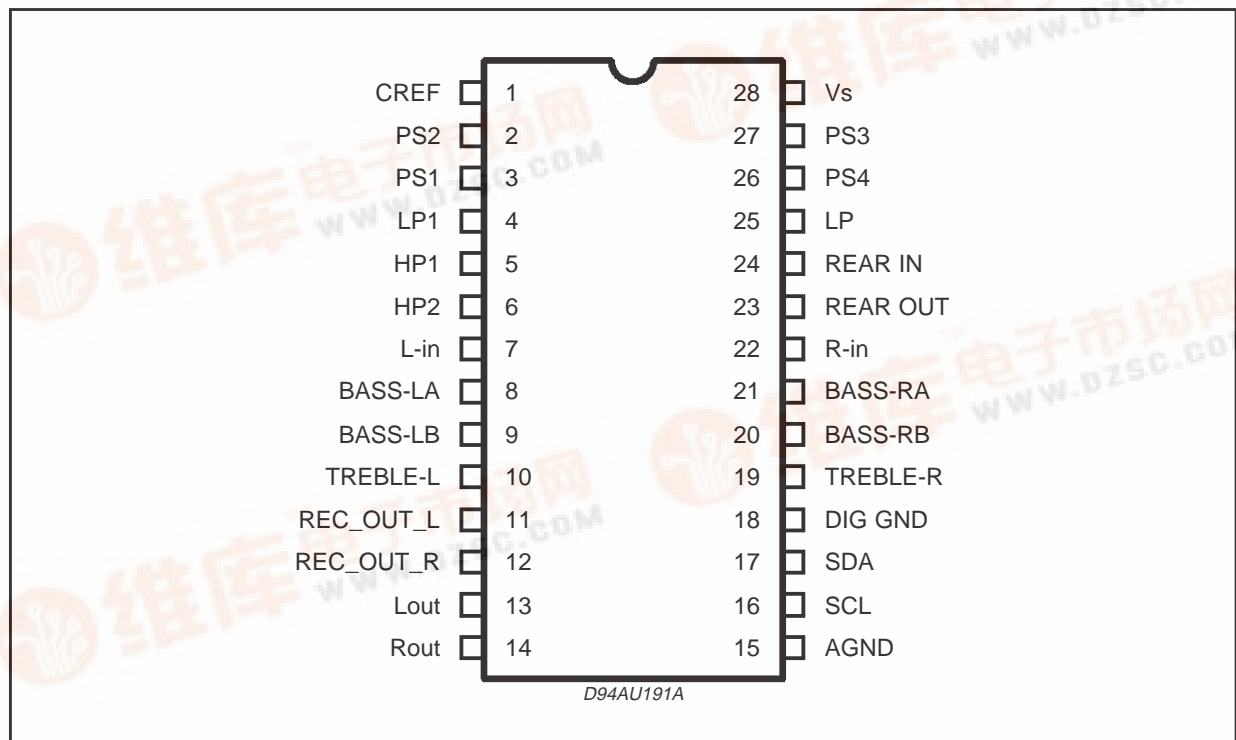

BLOCK DIAGRAM

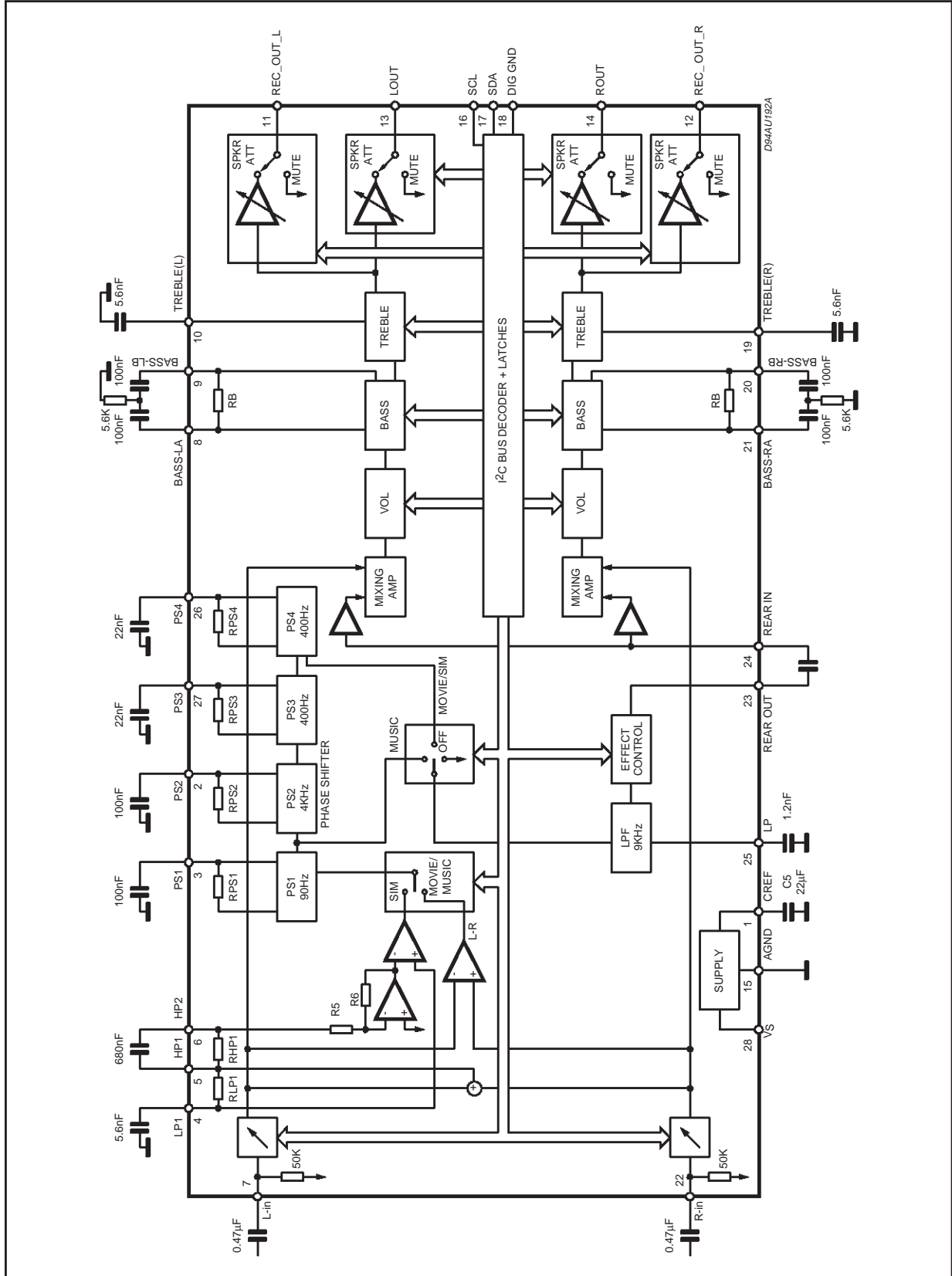

TEST CIRCUIT

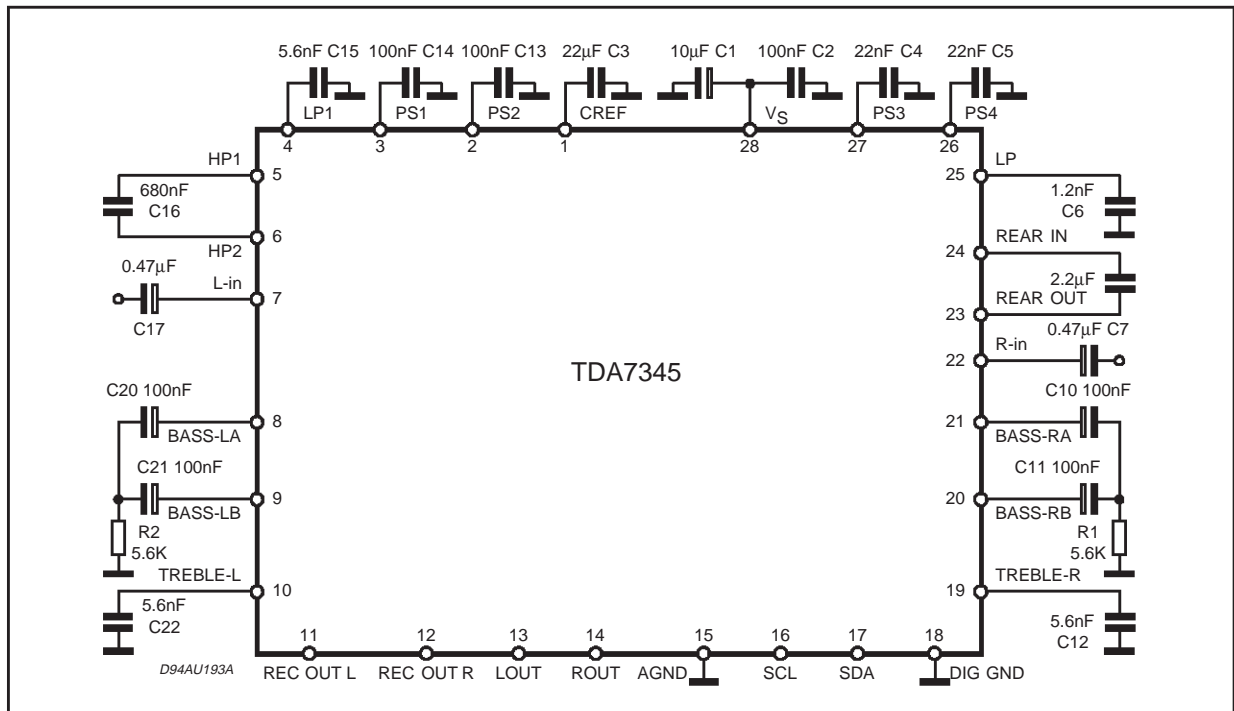

THERMAL DATA

Symbol	Description	Value	Unit
R <sub>thj-pins</sub>	Thermal Resistance Junction-pins	Max.	85 °C/W

ABSOLUTE MAXIMUM RATINGS

Symbol	Parameter	Value	Unit
V <sub>S</sub>	Operating Supply Voltage	11	V
T <sub>amb</sub>	Operating Ambient Temperature	-10 to 85	°C
T <sub>stg</sub>	Storage Temperature Range	-55 to +150	°C

QUICK REFERENCE DATA

Symbol	Parameter	Min.	Typ.	Max.	Unit
V <sub>S</sub>	Supply Voltage	7	9	10.5	V
V <sub>CL</sub>	Max. input signal handling	2			V <sub>rms</sub>
THD	Total Harmonic Distortion V = 1V <sub>rms</sub> f = 1KHz		0.02	0.1	%
S/N	Signal to Noise Ratio V <sub>out</sub> = 1V <sub>rms</sub> (made = OFF)		106		dB
S <sub>C</sub>	Channel Separation f = 1KHz		70		dB
	Volume Control 1.25dB step	-78.75		0	dB
	Treble Control (2db step)	-14		+14	dB
	Bass Control (2db step)	-14		+14	dB
	Balance Control 1.25dB step REC-OUT L & R	-38.75		0	dB
	Balance Control 1.25dB step (LOUT, ROUT)	-78.75		0	dB
	Mute Attenuation		90		dB

## TDA7345

**ELECTRICAL CHARACTERISTICS** (refer to the test circuit  $T_{amb} = 25^{\circ}\text{C}$ ,  $V_S = 9\text{V}$ ,  $R_L = 10\text{K}\Omega$ ,  $R_G = 600\Omega$ , all controls flat ( $G = 0$ ), Effect Ctrl = -6dB, MODE = OFF;  $f = 1\text{KHz}$  unless otherwise specified)

Symbol	Parameter	Test Condition	Min.	Typ.	Max.	Unit
--------	-----------	----------------	------	------	------	------

### SUPPLY

$V_S$	Supply Voltage		7	9	10.5	V
$I_S$	Supply Current		20	25	35	mA
SVR	Ripple Rejection	LCH / RCH out, Mode = OFF	60	80		dB

### INPUT STAGE

$R_{II}$	Input Resistance		35	50	65	$\text{K}\Omega$
$V_{CL}$	Clipping Level	THD = 0.3%; Lin or Rin	2	2.5		Vrms
		THD = 0.3%; Rin + Lin (2)		3.0		Vrms
$C_{RANGE}$	Control Range			19.68		dB
$A_{VMIN}$	Min. Attenuation		-1	0	1	dB
$A_{VMAX}$	Max. Attenuation		18.68	19.68	20.68	dB
$A_{STEP}$	Step Resolution		0.11	0.31	0.51	dB
$V_{DC}$	DC Steps	adjacent att. step	-3	0	3	mV

### VOLUME CONTROL

$C_{RANGE}$	Control Range		70	75		dB
$A_{VMIN}$	Min. Attenuation		-1	0	1	dB
$A_{VMAX}$	Max. Attenuation		70	75		dB
$A_{STEP}$	Step Resolution	$A_v = 0$ to -40dB	0.5	1.25	1.75	dB
$E_A$	Attenuation Set Error	$A_v = 0$ to -20dB	-1.5	0	1.5	dB
		$A_v = -20$ to -60dB	-3		2	dB
$E_T$	Tracking Error				2	dB
$V_{DC}$	DC Steps	adjacent attenuation steps	-3	0	3	mV

### BASS CONTROL (1)

$G_b$	Control Range	Max. Boost/cut	$\pm 11.5$	$\pm 14.0$	$\pm 16.0$	dB
$B_{STEP}$	Step Resolution		1	2	3	dB
$R_B$	Internal Feedback Resistance		32	44	56	$\text{K}\Omega$

### TREBLE CONTROL (1)

$G_t$	Control Range	Max. Boost/cut	$\pm 13$	$\pm 14$	$\pm 15$	dB
$T_{STEP}$	Step Resolution		1	2	3	dB

### EFFECT CONTROL

$C_{RANGE}$	Control Range		-21		-6	dB
$S_{STEP}$	Step Resolution		0.5	1	1.5	dB

**ELECTRICAL CHARACTERISTICS** (continued)  
**SURROUND SOUND MATRIX**

Symbol	Parameter	Test Condition	Min.	Typ.	Max.	Unit
G <sub>OFF</sub>	In-phase Gain (OFF)	Mode OFF, Input signal of 1kHz, 1.4 V <sub>p-p</sub> , R <sub>in</sub> → R <sub>out</sub> L <sub>in</sub> → L <sub>out</sub>	-1.5	0	1.5	dB
D <sub>G<sub>OFF</sub></sub>	LR In-phase Gain Difference (OFF)	Mode OFF, Input signal of 1kHz, 1.4 V <sub>p-p</sub> (R <sub>in</sub> → R <sub>out</sub> ), (L <sub>in</sub> → L <sub>out</sub> )	-1.5	0	1.5	dB
G <sub>MOV1</sub>	In-phase Gain (Movie 1)	Movie mode, Effect Ctrl = -6dB Input signal of 1kHz, 1.4 V <sub>p-p</sub> R <sub>in</sub> → R <sub>out</sub> , L <sub>in</sub> → L <sub>out</sub>		7		dB
G <sub>MOV2</sub>	In-phase Gain (Movie 2)	Movie mode, Effect Ctrl = -6dB Input signal of 1kHz, 1.4 V <sub>p-p</sub> R <sub>in</sub> → R <sub>out</sub> , L <sub>in</sub> → L <sub>out</sub>		8		dB
D <sub>G<sub>MOV</sub></sub>	LR In-phase Gain Difference (Movie)	Movie mode, Effect Ctrl = -6dB Input signal of 1kHz, 1.4 V <sub>p-p</sub> (R <sub>in</sub> → R <sub>out</sub> ) - (L <sub>in</sub> → L <sub>out</sub> )		0		dB
G <sub>MUS1</sub>	In-phase Gain (Music 1)	Music mode, Effect Ctrl = -6dB Input signal of 1kHz, 1.4 V <sub>p-p</sub> (R <sub>in</sub> → R <sub>out</sub> ) - (L <sub>in</sub> → L <sub>out</sub> )		6		dB
G <sub>MUS2</sub>	In-phase Gain (Music 2)	Music mode, Effect Ctrl = -6dB Input signal of 1kHz, 1.4 V <sub>p-p</sub> R <sub>in</sub> → R <sub>out</sub> , L <sub>in</sub> → L <sub>out</sub>		7.5		dB
D <sub>G<sub>MUS</sub></sub>	LR In-phase Gain Difference (Music)	Music mode, Effect Ctrl = -6dB Input signal of 1kHz, 1.4 V <sub>p-p</sub> (R <sub>in</sub> → R <sub>out</sub> ) - (L <sub>in</sub> → L <sub>out</sub> )		0		dB
L <sub>MON1</sub>	Simulated L Output 1	Simulated Mode, Effect Ctrl = -6dB Input signal of 250Hz, 1.4 V <sub>p-p</sub> , R <sub>in</sub> and L <sub>in</sub> → L <sub>out</sub>		4.5		dB
L <sub>MON2</sub>	Simulated L Output 2	Simulated Mode, Effect Ctrl = -6dB Input signal of 1kHz, 1.4 V <sub>p-p</sub> , R <sub>in</sub> and L <sub>in</sub> → L <sub>out</sub>		- 4.0		dB
L <sub>MON3</sub>	Simulated L Output 3	Simulated Mode, Effect Ctrl = -6dB Input signal of 3.6kHz, 1.4 V <sub>p-p</sub> , R <sub>in</sub> and L <sub>in</sub> → L <sub>out</sub>		7.0		dB
R <sub>MON1</sub>	Simulated R Output 1	Simulated Mode, Effect Ctrl = -6dB Input signal of 250Hz, 1.4 V <sub>p-p</sub> , R <sub>in</sub> and L <sub>in</sub> → R <sub>out</sub>		- 4.5		dB
R <sub>MON2</sub>	Simulated R Output 2	Simulated Mode, Effect Ctrl = -6dB Input signal of 1kHz, 1.4 V <sub>p-p</sub> , R <sub>in</sub> and L <sub>in</sub> → R <sub>out</sub>		3.8		dB
R <sub>MON3</sub>	Simulated R Output 3	Simulated Mode, Effect Ctrl = -6dB Input signal of 3.6kHz, 1.4 V <sub>p-p</sub> , R <sub>in</sub> and L <sub>in</sub> → R <sub>out</sub>		- 20		dB
R <sub>LP1</sub>	Low Pass Filter Resistance		7.5	10	12.5	KΩ
R <sub>PS1</sub>	Phase Shifter 1 Resistance		13.5	17.95	22.5	kΩ
R <sub>PS2</sub>	Phase Shifter 2 Resistance		0.30	0.40	0.50	KΩ
R <sub>PS3</sub>	Phase Shifter 3 Resistance		13.6	18.08	22.6	KΩ
R <sub>PS2</sub>	Phase Shifter 4 Resistance		13.6	18.08	22.6	KΩ
R <sub>HPI</sub>	High Pass Filter Resistance		45	60	75	KΩ
R <sub>LPF</sub>	LP Pin Impedance		7.5	10	12.5	KΩ

## TDA7345

### ELECTRICAL CHARACTERISTICS (continued)

Symbol	Parameter	Test Condition	Min.	Typ.	Max.	Unit
<b>SPEAKER ATTENUATORS (REC_OUT_L, REC_OUT_R)</b>						
C <sub>range</sub>	Control Range		35	37.5	40	dB
S <sub>STEP</sub>	Step Resolution		0.5	1.25	1.75	dB
E <sub>A</sub>	Attenuation set error		-1.5		1.5	dB
A <sub>MUTE</sub>	Output Mute Attenuation		80	90		dB
V <sub>DC</sub>	DC Steps	adjacent att. steps	-3	0	3	mV

### SPEAKER ATTENUATORS (LOUT, ROUT)

Symbol	Parameter	Test Condition	Min.	Typ.	Max.	Unit
C <sub>range</sub>	Control Range		70	75		dB
S <sub>STEP</sub>	Step Resolution	Av = 0 to -40dB	0.5	1.25	1.75	dB
E <sub>A</sub>	Attenuation set error	Av = 0 to 20dB	-1.5	0	1.5	dB
		Av = -20 to -60dB	-3	0	2	dB
V <sub>DC</sub>	DC Steps	adjacent att. steps	-3	0	3	mV
A <sub>MUTE</sub>	Output Mute Attenuation		80	90		dB

### AUDIO OUTPUTS (LOUT, ROUT, REC\_OUT\_L, REC\_OUT\_R)

Symbol	Parameter	Test Condition	Min.	Typ.	Max.	Unit
V <sub>OCL</sub>	Clipping Level	d = 0.3%	2	2.5		V <sub>rms</sub>
R <sub>OUT</sub>	Output resistance		100	200	300	Ω
V <sub>OUT</sub>	DC Voltage Level		4.2	4.5	4.8	V

### GENERAL

Symbol	Parameter	Test Condition	Min.	Typ.	Max.	Unit
N <sub>O(OFF)</sub>	Output Noise (OFF)	B <sub>W</sub> = 20Hz to 20KHz Output LOUT, ROUT, Output: REC-OUT-L, REC-OUT-R		8 8	15 15	μV <sub>rms</sub> μV <sub>rms</sub>
N <sub>O(MOV)</sub>	Output Noise (Movie)	Mode = Movie, B <sub>W</sub> = 20Hz to 20KHz R <sub>out</sub> and L <sub>out</sub> measurement		30		μV <sub>rms</sub>
N <sub>O(MUS)</sub>	Output Noise (Music)	Mode = Music, B <sub>W</sub> = 20Hz to 20KHz, R <sub>out</sub> and L <sub>out</sub> measurement		30		μV <sub>rms</sub>
N <sub>O(MON)</sub>	Output Noise (Simulated)	Mode = Simulated, B <sub>W</sub> = 20Hz to 20KHz R <sub>out</sub> and L <sub>out</sub> measurement		30		μV <sub>rms</sub>
d	Distorsion	Av = 0 ; V <sub>in</sub> = 1V <sub>rms</sub>		0.02	0.1	%
S <sub>C</sub>	Channel Separation		60	70		dB

### BUS INPUTS

Symbol	Parameter	Test Condition	Min.	Typ.	Max.	Unit
V <sub>IL</sub>	Input Low Voltage				1	V
V <sub>IH</sub>	Input High Voltage		3			V
I <sub>IN</sub>	Input Current		-5		+5	μA
V <sub>O</sub>	Output Voltage SDA Acknowledge	I <sub>O</sub> = 1.6mA		0.4	0.8	V

Note:

(1) Bass and Treble response: The center frequency and the resonance quality can be chosen by the external circuitry. A standard first order bass response can be realized by a standard feedback network.

(2) The peak voltage of the two input signals must be less than  $\frac{V_S}{2}$ :

$$(I_{in} + R_{in})_{peak} \cdot A_{Vin} < \frac{V_S}{2}$$

### I<sup>2</sup>C BUS INTERFACE

Data transmission from microprocessor to the TDA7345 and viceversa takes place through the 2 wires I<sup>2</sup>C BUS interface, consisting of the two lines SDA and SCL (pull-up resistors to positive supply voltage must be connected).

#### Data Validity

As shown in fig. 3, the data on the SDA line must be stable during the high period of the clock. The HIGH and LOW state of the data line can only change when the clock signal on the SCL line is LOW.

#### Start and Stop Conditions

As shown in fig.4 a start condition is a HIGH to LOW transition of the SDA line while SCL is HIGH. The stop condition is a LOW to HIGH transition of the SDA line while SCL is HIGH.

#### Byte Format

Every byte transferred on the SDA line must contain 8 bits. Each byte must be followed by an ac-

knowledge bit. The MSB is transferred first.

#### Acknowledge

The master ( $\mu$ P) puts a resistive HIGH level on the SDA line during the acknowledge clock pulse (see fig. 5). The peripheral (audioprocessor) that acknowledges has to pull-down (LOW) the SDA line during the acknowledge clock pulse, so that the SDA line is stable LOW during this clock pulse.

The audioprocessor which has been addressed has to generate an acknowledge after the reception of each byte, otherwise the SDA line remains at the HIGH level during the ninth clock pulse time. In this case the master transmitter can generate the STOP information in order to abort the transfer.

#### Transmission without Acknowledge

Avoiding to detect the acknowledge of the audioprocessor, the  $\mu$ P can use a simpler transmission: simply it waits one clock without checking the slave acknowledging, and sends the new data.

This approach of course is less protected from misworking and decreases the noise immunity.

Figure 3: Data Validity on the I<sup>2</sup>CBUS

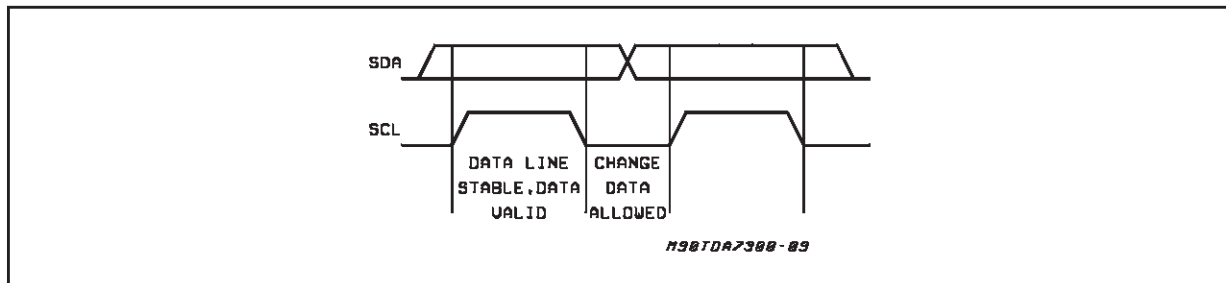

Figure 4: Timing Diagram of I<sup>2</sup>CBUS

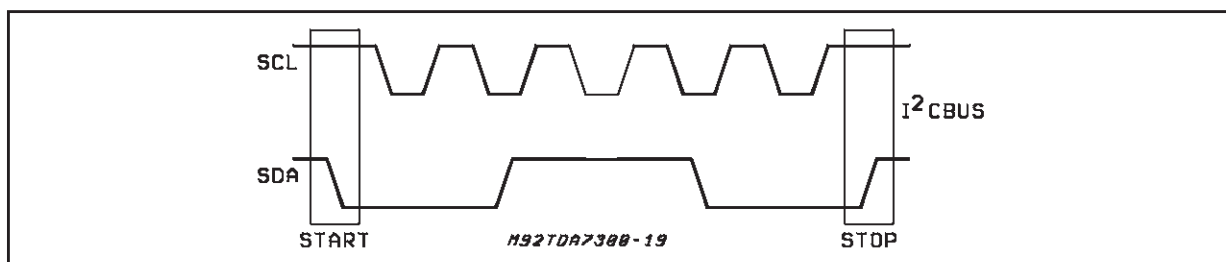
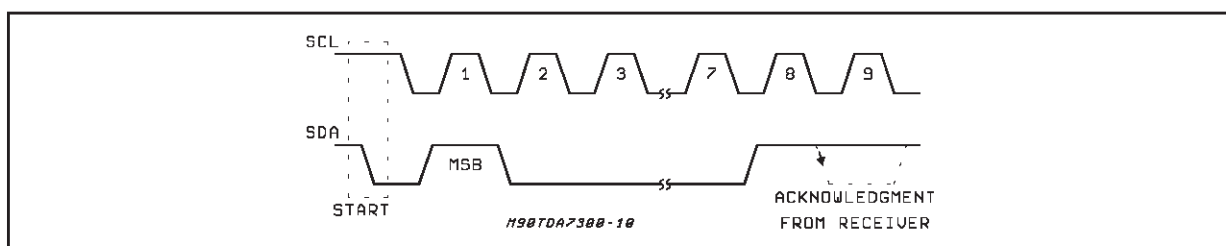

Figure 5: Acknowledge on the I<sup>2</sup>CBUS



# TDA7345

## SOFTWARE SPECIFICATION

### Interface Protocol

The interface protocol comprises:

- A start condition (s)
- A chip address byte, containing the TDA7345 address (the 8th bit of the byte must be 0).  
The TDA7345 must always acknowledge at

the end of each transmitted byte.

- A subaddress (function) bytes (identified by the MSB = 0)
- A sequence of dates and subaddresses (N bytes + acknowledge. The dates are identified by MSB = 1, subaddresses by MSB = 0)
- A stop condition (P)

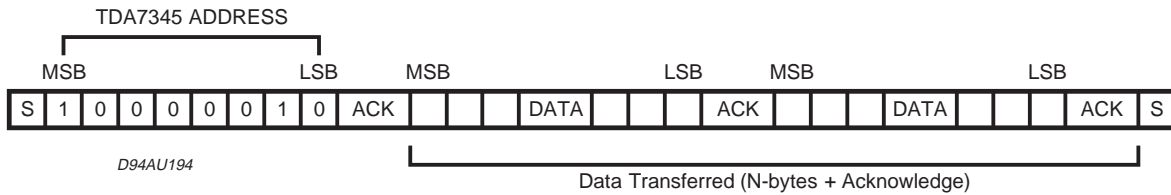

ACK = Acknowledge  
S = Start  
P = Stop

## INTERFACE FEATURES

- Due to the fact that the MSB is used to select if the byte transmitted is a subaddress (function) or a data (value), between a start and stop condition, is possible to receive, how many subaddresses and datas as wanted.
- The subaddress (function) is fixed until a new subaddress is transmitted, so the TDA7345 can receive how many data as wanted for the selected subaddress (without the need for a new start condition)
- If TDA7345 receives a subaddress with the LSB = 1 the incremental bus is selected, so it enters in a loop condition that means that every acknowledge will increase automatically the subaddress (function) and it receives the data related to the new subaddress.

chip address, a subaddress with the LSB = 0 (no incremental bus), N-datas (all these datas concern the subaddress selected), a new subaddress, N-data, a stop condition. So it can receive in a single transmission how many subaddress are necessary, and for each subaddress how many data are necessary.

### 2) INCREMENTAL BUS

TDA7345 receives a start condition, the correct chip address a subaddress with the LSB = 1 (incremental bus): now it is in a loop condition with an autoincrease of the subaddress. The first data that it receives doesn't concern the subaddress sended but the next one, the second one concerns the subaddress sended plus two in the loop etc, and at the end it receives the stop condition.

In the pictures there are some examples:

S = start  
ACK = acknowledge  
B = 1 incremental bus, B = 0 no incremental bus  
P = stop

## EXAMPLES

### 1) NO INCREMENTAL BUS

TDA7345 receives a start condition, the correct

- 1) one subaddress, with n data concerning that subaddress (no incremental bus)

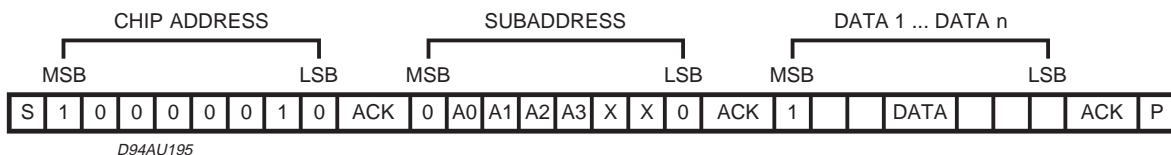

- 2) one subaddress, (with incremental bus) , with n data (data1 that concerns subaddress+1, data 2 that concerns subaddress+ 2 etc.)

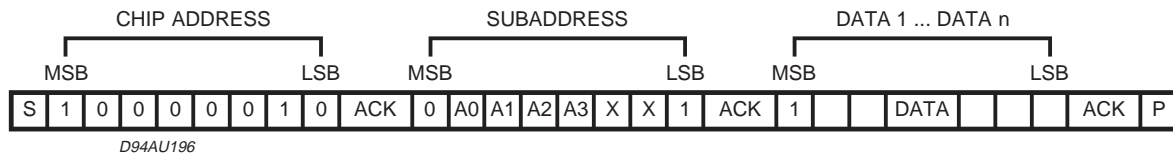

- 3) more subaddress with more data

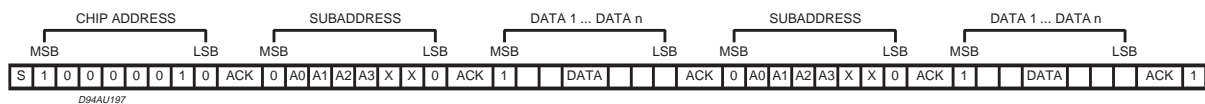

### DATA BYTES

FUNCTION SELECTION  
FIRST BYTE (subaddress)

The first byte select the function, it is identified by the MSB = 0

MSB	A0	A1	A2	A3			LSB	SUBADDRESS
0	0	0	0	X	X	X	B	VOLUME ATTENUATION & LOUDNESS
0	1	0	0	X	X	X	B	SURROUND & OUT & EFFECT CONTROL
0	0	1	0	X	X	X	B	BASS
0	1	1	0	X	X	X	B	TREBLE
0	0	0	1	X	X	X	B	REC-OUT-R
0	1	0	1	X	X	X	B	REC-OUT-L
0	0	1	1	X	X	X	B	Rout
0	1	1	1	0	X	X	B	Lout
0	1	1	1	1	X	X	B	INPUT STAGE CONTROL

B = 1 yes incremental bus;  
B = 0 no incremental bus;  
X = indifferent 0,1

## TDA7345

### VALUE SELECTION

The second byte select the value, it is identified by the MSB = 1

VOLUME ATTENUATION								
MSB							LSB	1.25 dB STEPS
1					0	0	0	0
1					0	0	1	-1.25
1					0	1	0	-2.50
1					0	1	1	-3.75
1					1	0	0	-5.00
1					1	0	1	-6.25
1					1	1	0	-7.50
1					1	1	1	-8.75
								<b>10 dB STEPS</b>
1		0	0	0				0
1		0	0	1				-10
1		0	1	0				-20
1		0	1	1				-30
1		1	0	0				-40
1		1	0	1				-50
1		1	1	0				-60
1		1	1	1				-70

ATT SPEAKER L AND R								
MSB							LSB	1.25 dB STEPS
1					0	0	0	0
1					0	0	1	-1.25
1					0	1	0	-2.50
1					0	1	1	-3.75
1					1	0	0	-5.00
1					1	0	1	-6.25
1					1	1	0	-7.50
1					1	1	1	-8.75
								<b>10 dB STEPS</b>
1		0	0	0				0
1		0	0	1				-10
1		0	1	0				-20
1		0	1	1				-30
1		1	0	0				-40
1		1	0	1				-50
1		1	1	0				-60
1		1	1	1				-70
								<b>MUTE</b>
1	0							OFF
1	1							ON

ATT REC-OUT L AND R								
MSB							LSB	1.25 dB STEPS
1	X	X			0	0	0	0
1	X	X			0	0	1	-1.25
1	X	X			0	1	0	-2.50
1	X	X			0	1	1	-3.75
1	X	X			1	0	0	-5.00
1	X	X			1	0	1	-6.25
1	X	X			1	1	0	-7.50
1	X	X			1	1	1	-8.75
								10 dB STEPS
1	X	X	0	0				0
1	X	X	0	1				-10
1	X	X	1	0				-20
1	X	X	1	1				-30
1	X	X	1	1	1	1	1	MUTE

TREBLE/ BASS								
MSB							LSB	2 dB STEPS
1	X	X	X	0	1	1	1	14
1	X	X	X	0	1	1	0	12
1	X	X	X	0	1	0	1	10
1	X	X	X	0	1	0	0	8
1	X	X	X	0	0	1	1	6
1	X	X	X	0	0	1	0	4
1	X	X	X	0	0	0	1	2
1	X	X	X	0	0	0	0	0
1	X	X	X	1	0	0	0	0
1	X	X	X	1	0	0	1	-2
1	X	X	X	1	0	1	0	-4
1	X	X	X	1	0	1	1	-6
1	X	X	X	1	1	0	0	-8
1	X	X	X	1	1	0	1	-10
1	X	X	X	1	1	1	0	-12
1	X	X	X	1	1	1	1	-14

**TDA7345**

SURROUND & OUT & EFFECT CONTROL									
MSB							LSB	SELECTION	
SELECTION								SURROUND	
1							0	0	SIMULATED
1							0	1	MUSIC
1							1	0	MOVIE
1							1	1	OFF
SELECTION								EFFECT CONTROL	
1	0	0	0	0					-6
1	0	0	0	1					-7
1	0	0	1	0					-8
1	0	0	1	1					-9
1	0	1	0	0					-10
1	0	1	0	1					-11
1	0	1	1	0					-12
1	0	1	1	1					-13
1	1	0	0	0					-14
1	1	0	0	1					-15
1	1	0	1	0					-16
1	1	0	1	1					-17
1	1	1	0	0					-18
1	1	1	0	1					-19
1	1	1	1	0					-20
1	1	1	1	1					-21

For example to select the music mode, out fix, effect control =-9dB:

1 0 0 1 1 1 0 1

INPUT CONTROL RANGE (0 TO -19.68dB)								
MSB						LSB	0.3125 dB STEPS	
1	X				0	0	0	0
1	Xx				0	0	1	-0.3125
1	X				0	1	0	-0.625
1	X				0	1	1	-0.9375
1	X				1	0	0	-1.25
1	X				1	0	1	-1.5625
1	X				1	1	0	-1.875
1	X				1	1	1	-2.1875
							2.5 dB STEPS	
1	X	0	0	0				0
1	X	0	0	1				-2.5
1	X	0	1	0				-5.0
1	X	0	1	1				-7.5
1	X	1	0	0				-10
1	X	1	0	1				-12.5
1	X	1	1	0				-15
1	X	1	1	1				-17.5

POWER ON RESET	
VOLUME ATTENUATION	MAX ATTENUATION,
TREBLE	-14dB
BASS	-14dB
SURROUND + EFFECT CONTROL	OFF + MAX ATTENUATION
ATT SPEAKER R	MUTE
ATT SPEAKER L	MUTE
ATT REC-OUT L	MUTE
ATT REC-OUT R	MUTE

# TDA7345

**PIN: HP1**

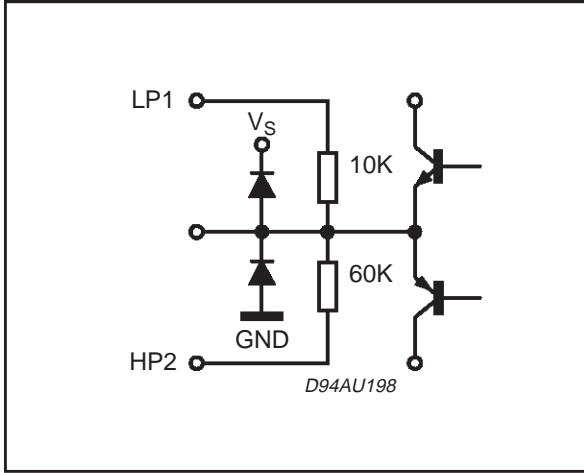

**PIN: HP2**

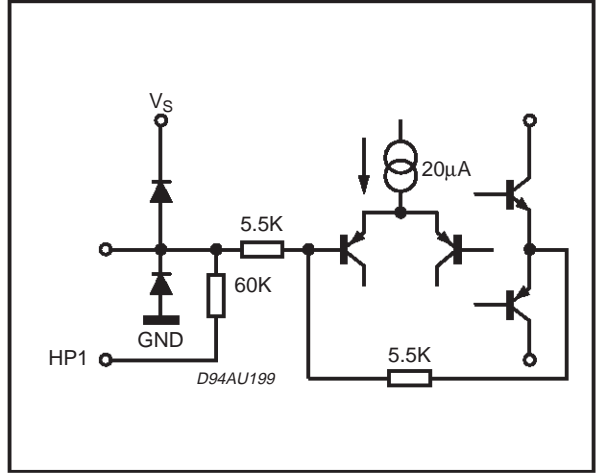

**PIN: Lin, Rin**

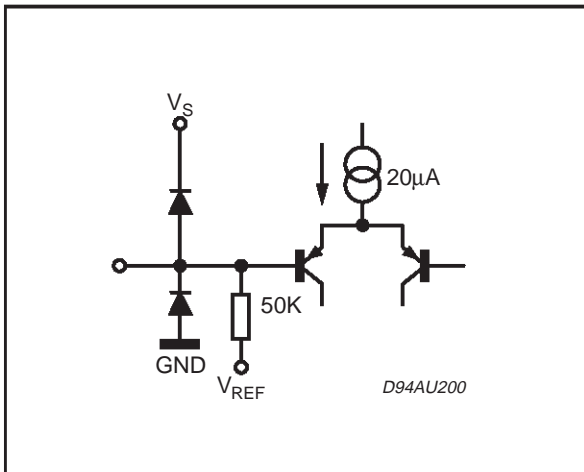

**PIN: BASS - LA, BASS - RA**

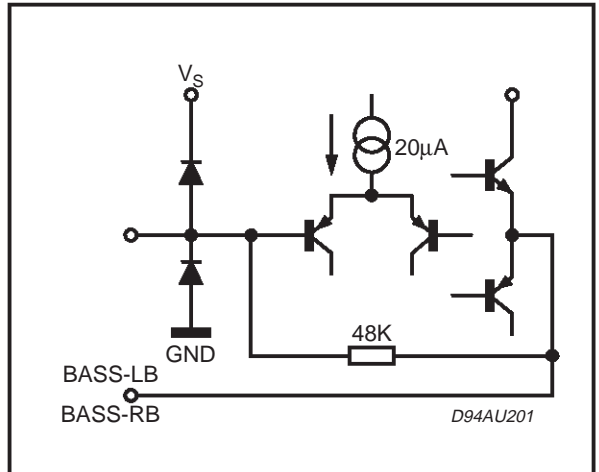

**PIN: BASS - LB, BASS - RB**

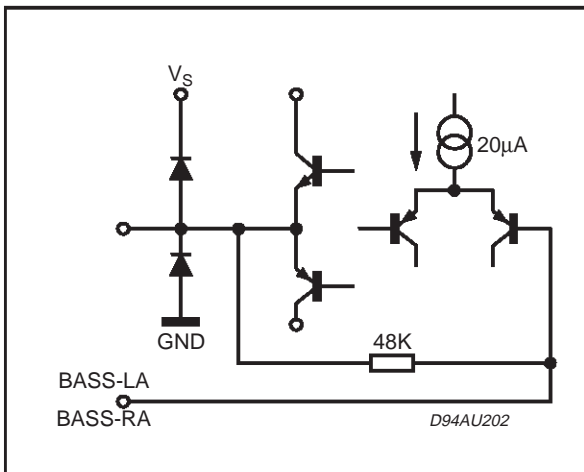

**PIN: TREBLE - L, TREBLE - R**

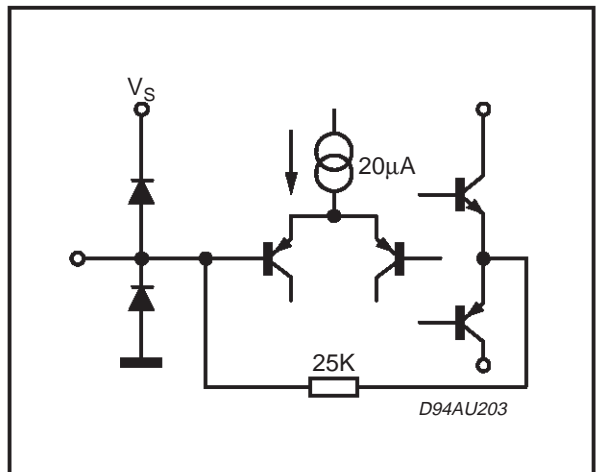

**PIN:** L<sub>OUT</sub>, R<sub>OUT</sub>, REC-OUT-1 REC-OUT-R

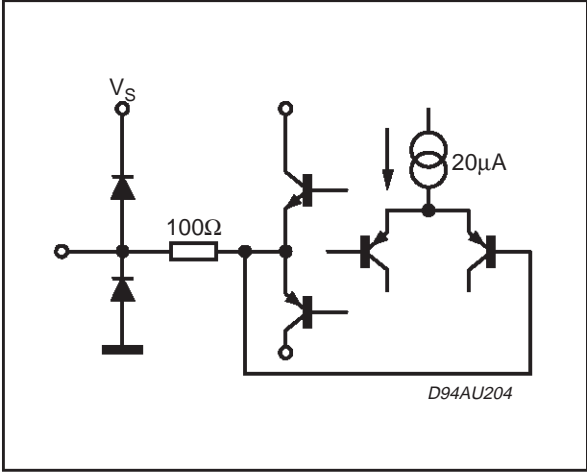

**PIN:** SCL, SDA

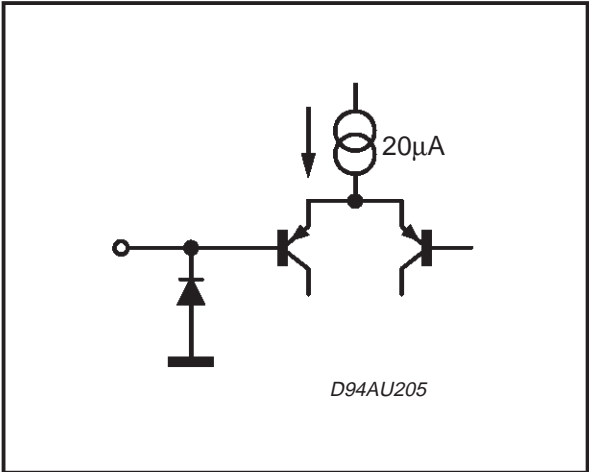

**PIN:** LP

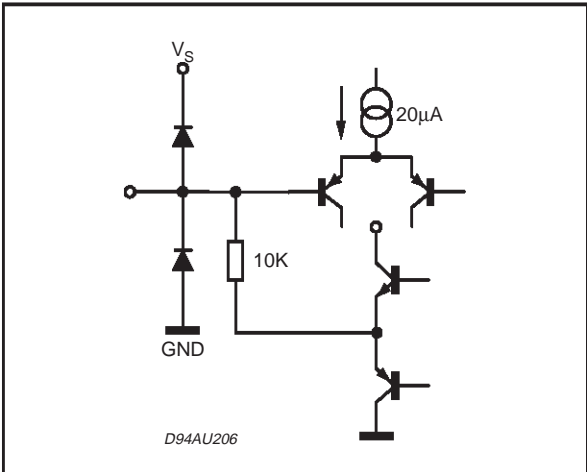

**PIN:** PS3, PS2

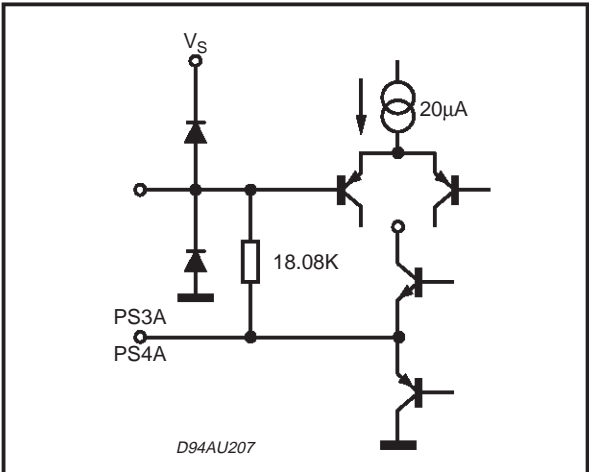

**PIN:** C<sub>REF</sub>

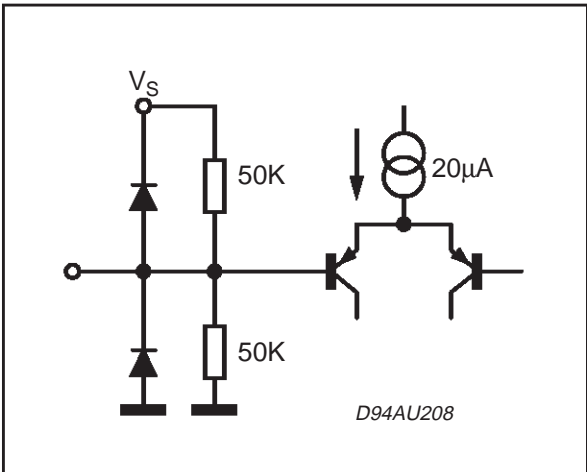

**PIN:** PS2

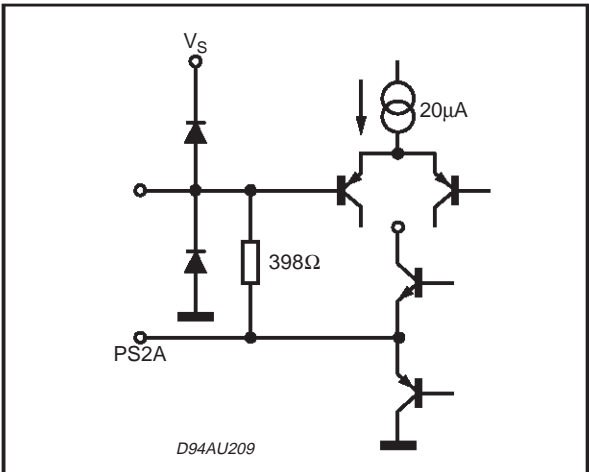

# TDA7345

**PIN: PS1**

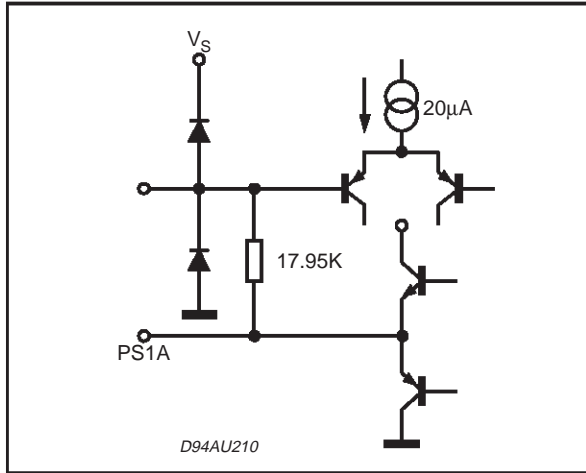

**PIN: LP1**

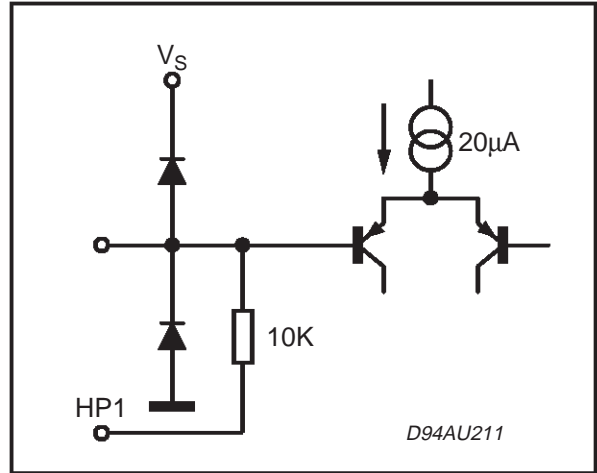

**PIN: REAR OUT**

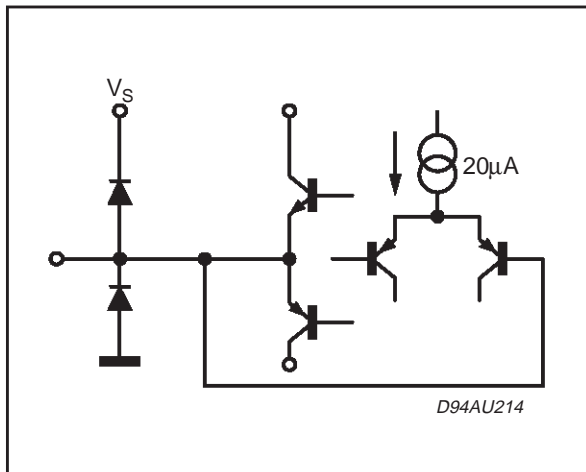

**PIN: REAR IN**

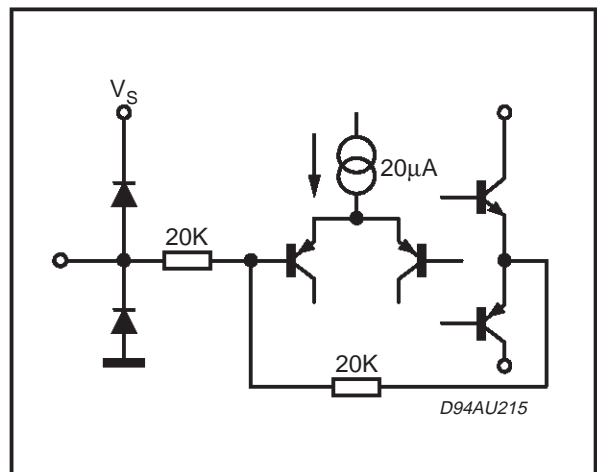

DIM.	mm			inch		
	MIN.	TYP.	MAX.	MIN.	TYP.	MAX.
A			2.65			0.104
a1	0.1		0.3	0.004		0.012
b	0.35		0.49	0.014		0.019
b1	0.23		0.32	0.009		0.013
C		0.5			0.020	
c1	45° (typ.)					
D	17.7		18.1	0.697		0.713
E	10		10.65	0.394		0.419
e		1.27			0.050	
e3		16.51			0.65	
F	7.4		7.6	0.291		0.299
L	0.4		1.27	0.016		0.050
S	8° (max.)					

**OUTLINE AND MECHANICAL DATA**

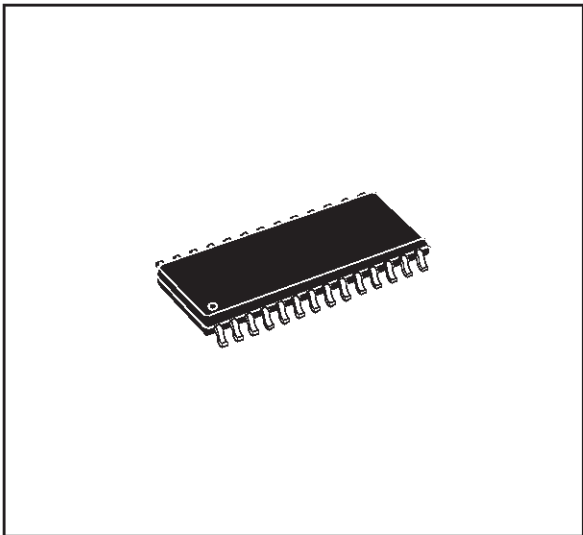

**SO28**

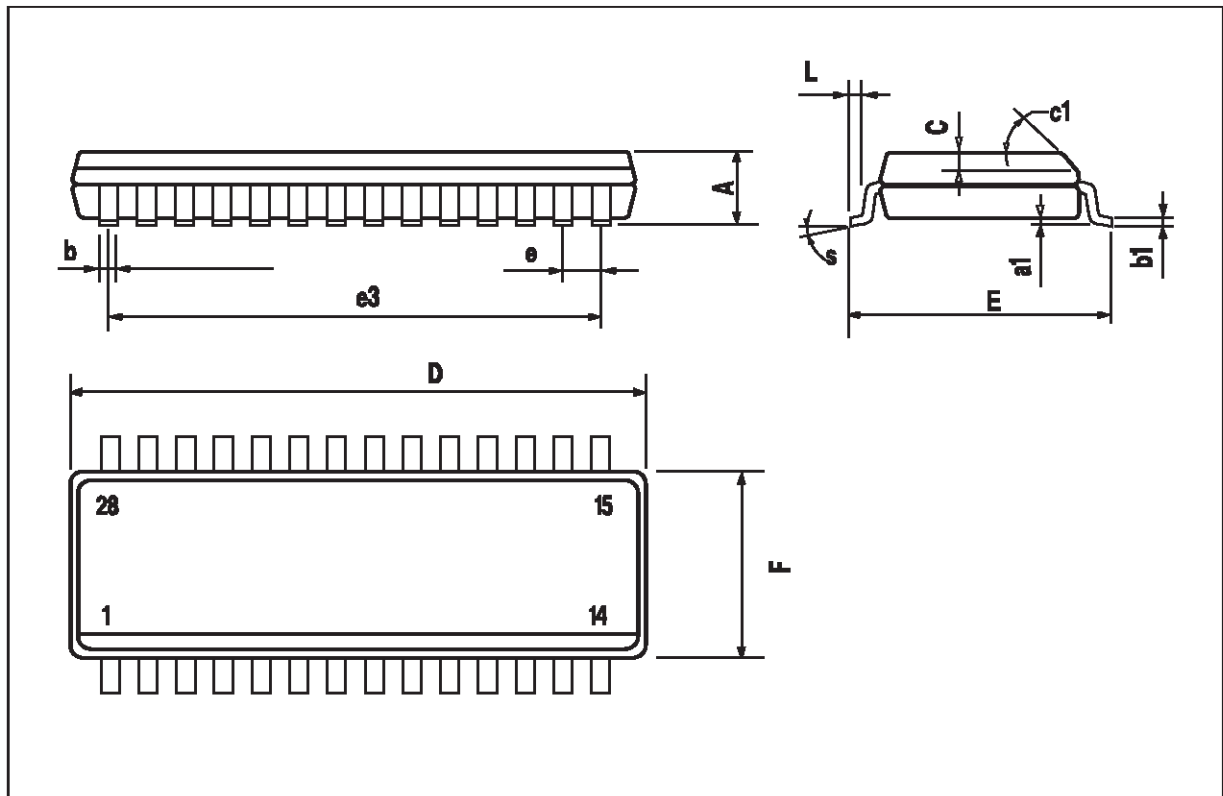

Information furnished is believed to be accurate and reliable. However, STMicroelectronics assumes no responsibility for the consequences of use of such information nor for any infringement of patents or other rights of third parties which may result from its use. No license is granted by implication or otherwise under any patent or patent rights of STMicroelectronics. Specification mentioned in this publication are subject to change without notice. This publication supersedes and replaces all information previously supplied. STMicroelectronics products are not authorized for use as critical components in life support devices or systems without express written approval of STMicroelectronics.

The ST logo is a registered trademark of STMicroelectronics

© 1999 STMicroelectronics – Printed in Italy – All Rights Reserved

STMicroelectronics GROUP OF COMPANIES

Australia - Brazil - China - Finland - France - Germany - Hong Kong - India - Italy - Japan - Malaysia - Malta - Morocco -  
Singapore - Spain - Sweden - Switzerland - United Kingdom - U.S.A.

<http://www.st.com>