

DBL 5022

[查询DBL 5022供应商](#)

[捷多邦, 专业PCB打样工厂](#)

[, 24小时加急出货](#)

UNIVERSAL SPEECH NETWORK

The DBL 5022 can fulfill the standards of other countries by changing the external component.

Dynamic or piezoelectric type can be used with receiver. Each gain is controlled with AGC in accordance with the line current. The DBL 5022 can be operated down to DC line 1.6V

FEATURES

- Independent adjustment of DC resistance and AC impedance.
- Voltage regulator with adjustable static resistance
- Symmetrical high-impedance inputs for dynamic magnetic or piezo-electric microphones
- Receiving amplifier for dynamic, magnetic or piezo-electric earpieces
- DTMF signal interface
- Low DC line voltage : operateds down to 1.6V
- Mute function
- DC line voltage adjustment facility

16DIP

Unit : mm

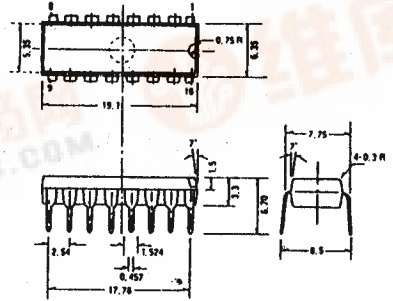

16SOP

DBL 5022-V

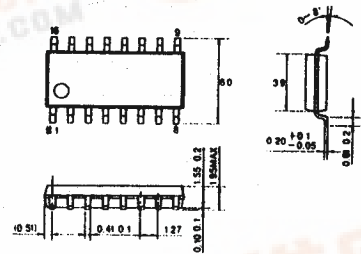

MAXIMUM RATINGS

Characteristic	Symbol	Rating	Unit
Line Voltage	V_L	12	V
Line Current	I_L	140	mA
Power Dissipation	P_D	666	mW
Operating Temperature	T_{OP}	-25 ~ +70	°C
Storage Temperature	T_{STG}	-40 ~ +125	°C

DBL 5022

□ BLOCK DIAGRAM

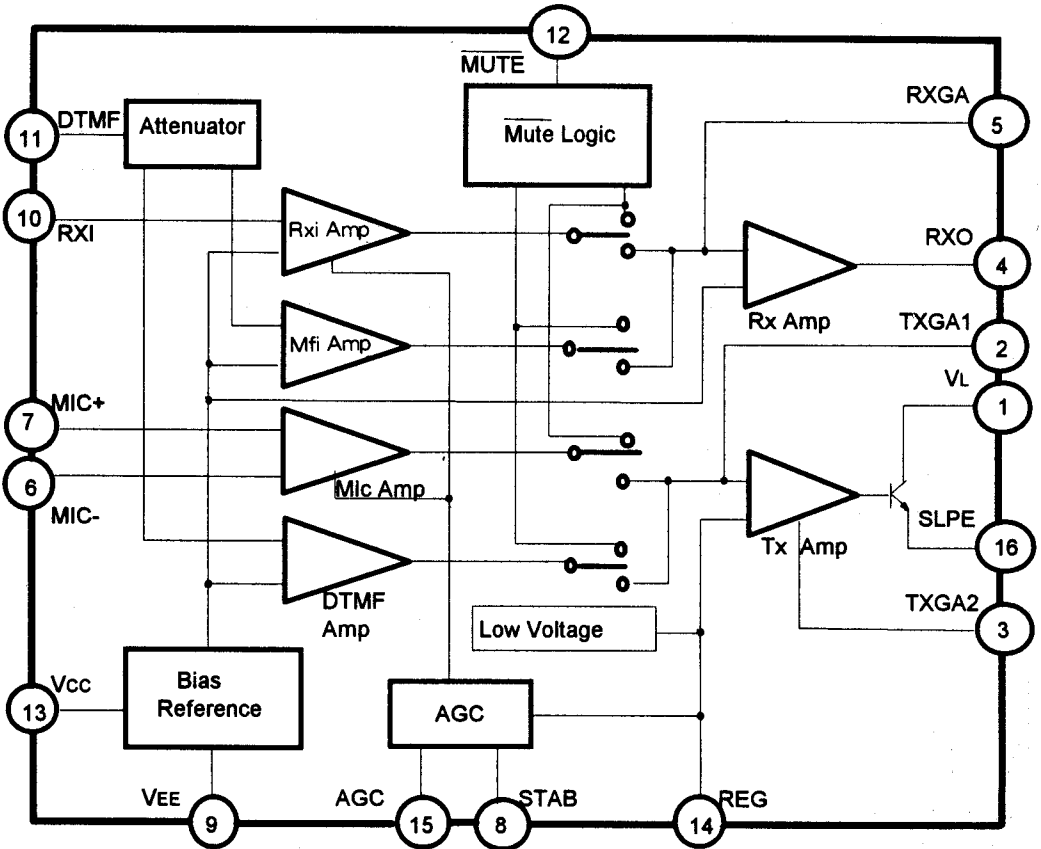

□ PIN DESCRIPTION

Pin No	Symbol	Description
1	VL	Positive power line and TX Amp output
2	TXGA1	TX gain adjustment
3	TXGA2	TX gain adjustment
4	RXO	RX output
5	RXGA	RX gain adjustment
6	MIC ⁻	Mic(-) Input
7	MIC ⁺	Mic(+) Input

DBL 5022

□ PIN DESCRIPTION

Pin No	Symbol	Description
8	SRAB	Current stabilizer
9	V_{EE}	Ground
10	RXI	Rx input
11	DTMF	DTMF signal input
12	\overline{MUTE}	'H' Mute input
13	V_{CC}	Internal power supply pin
14	REG	Voltage regulator decoupling
15	AGC	Automation gain control input
16	SLPE	Slope(DC resistance) adjustment

□ ELECTRICAL CHARACTERISTICS

Characteristic	Symbol	Test Condition	Min.	Typ.	Max.	Unit	
Line Voltage	V_L	I _{Line} = 1mA	—	1.6	—	V	
		I _{Line} = 4mA	—	1.9	—		
		I _{Line} = 15mA	3.55	4	4.25		
		I _{Line} = 100mA	4.9	5.7	6.5		
		I _{Line} = 140mA	—	—	7.5		
Variation with temperature	$\Delta V_L / \Delta T$	I _{Line} = 15mA	—	-0.3	—	mV/k	
Voltage drop over circuit between V_L & V_{EE} with external resistor R_{AV}	R_{VA}	I _{Line} = 15mA $R_{VA}(R_{EG} \text{ to } S_{LPE}) = 39K$	—	4.5	—	V	
		I _{Line} = 15mA $R_{VA}(V_L \text{ to } R_{EG}) = 68K$	—	3.5	—	V	
Supply Voltage	V_{CC}	$\overline{Mute} = \text{High}$	I _p = 1.2mA	2.2	2.7	—	V
			I _p = 0mA	—	3.4	—	
MIC input impedance	$Z_i(\text{mic})$	Between MIC- & MIC+	—	64	—	K Ω	
		MIC- or MIC+ to V-	—	32	—		
Common mode rejection ratio	CMRR(T _x)	—	—	82	—	dB	
TX Gain	$G_v(T_x)$	R7 = 68K, V _{in} = 3mV _{rms}	50.5	52	53.5	dB	
TX Gain frequency response	ΔG_{TXF}	f = 300 ~ 3400Hz	—	±0.2	—	dB	
DTMF input impedance	$Z_i(\overline{MF})$	—	—	20.7	—	K Ω	

DBL 5022

□ ELECTRICAL CHARACTERISTICS

Characteristic	Symbol	Test Condition	Min.	Typ.	Max.	Unit	
DTMF Gain	$G_{V(MF)}$	R7=68K, DTMF mode	24	25.5	27	dB	
DTMF Gain response	ΔG_{MF}	R7=68K, f=300~3400Hz	—	± 0.2	± 0.5	dB	
TX Gain adjustment	$\Delta G_{V,adj}(T_x)$	R7=68K→25K	- 12	- 8	- 7	dB	
TX Dynamic output voltage	$T_o(T_x)$	THD= 10%	IL= 4mA	—	0.8	—	Vrms
			IL= 15mA	1.7	2.3	—	
TX noise output voltage	$V_{no}(T_x)$	R7=68K Between pin6 & pin7=200 Ω	—	- 69	—	dBmp	
RX input impedance	$Z_i(R_x)$	—	—	21	—	K Ω	
RX output impedance	$Z_o(R_x)$	—	—	4	—	K Ω	
RX Gain	$G_V(R_x)$	R4= 100K, RL= 300 Ω	29.5	31	32.5	dB	
RX Gain frequency response	ΔG_{TXF}	f=300~3400Hz	—	± 0.2	—	dB	
RX Dynamic output voltage	$V_o(R_x)$	THD= 2% R4= 100K	RL= 150 Ω	0.22	0.33	—	V
			RL= 450 Ω	0.3	0.48	—	
RX noise output voltage	$V_{no}(R_x)$	RL= 300 Ω R4= 100K I _L = 15mA, Rx _i = open	—	50	—	μ V	
RX Gain adjustment	$\Delta G_{V,adj}(R_x)$	R4= 100K→28K	- 13	- 11	- 9	dB	
Mute input voltage	$V_H(\text{Mute})$	—	1.5	—	V_{CC}	V	
	$V_L(\text{Mute})$	—	—	—	0.3		
Mute input current	I_{MUTE}	—	—	8	15	μ A	
Mute attenuation	Matt(TX)	MIC+ or MIC- to V _L (CCIT weighted)	—	70	—	dB	
DTMF Gain	$G_V(\text{DTMF})$	voltage gain from DTMF to Rxo	—	- 19	—	dB	
TX Gain variation range by AGC	ΔG_{TXA}	R6= 110K IL= 15mA~70mA	—	- 5.8	—	dB	
RX Gain variation range by AGC	ΔG_{RXA}	R6= 110K IL= 15mA~70mA	—	- 5.8	—	dB	
Highest line current for maximum gain	$I_{HL(AGC)}$	R6= 110K	17	23	26	mA	
Lowest line current for minimum gain	$I_{LL(AGC)}$	R6= 110K	54	61	73	mA	

DBL 5022

TYPICAL PERFORMANCE CHARACTERISTICS

