



STTH5L06D/B/FP

TURBO 2 ULTRAFast HIGH VOLTAGE RECTIFIER

MAIN PRODUCT CHARACTERISTICS

$I_{F(AV)}$	5 A
V_{RRM}	600 V
$I_R(max)$	125 μ A
$T_j(max)$	175 °C
$V_F(max)$	1.05 V
$t_{rr}(max)$	95 ns

FEATURES AND BENEFITS

- Ultrafast switching
- Low reverse recovery current
- Reduces switching & conduction losses
- Low thermal resistance

DESCRIPTION

The STTH5L06D/B/FP, which is using ST Turbo 2 600V technology, is specially suited as boost diode in discontinuous or critical mode power factor corrections.

The device, available in TO-220AC, TO-220FPAC and DPAK, is also intended for use as a free wheeling diode in power supplies and other power switching applications.

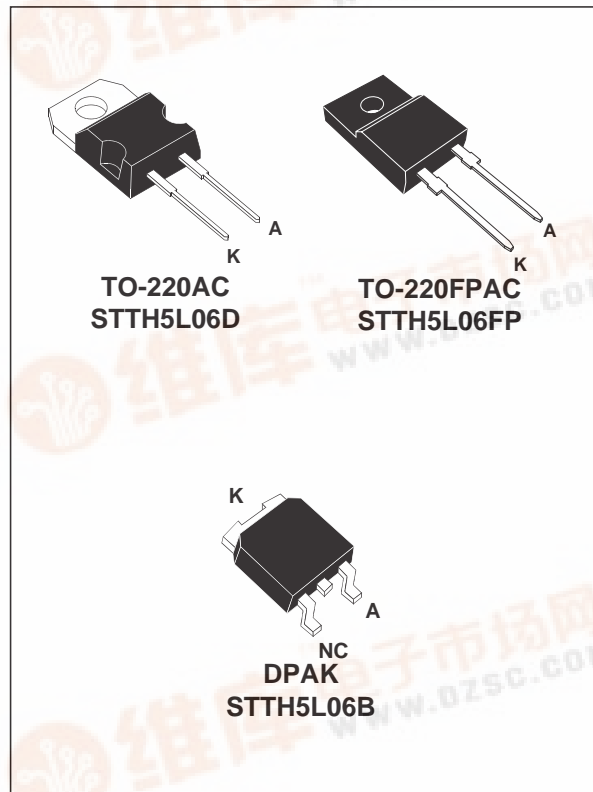

ABSOLUTE RATINGS (limiting values)

Symbol	Parameter		Value	Unit	
V_{RRM}	Repetitive peak reverse voltage		600	V	
$I_{F(RMS)}$	RMS forward current		TO-220AC/TO-220FPAC DPAK	20 10	A
$I_{F(AV)}$	Average forward current	TO-220AC / DPAK	$T_c = 150^\circ\text{C} \quad \delta = 0.5$	5	A
		TO-220FPAC	$T_c = 135^\circ\text{C} \quad \delta = 0.5$		
I_{FSM}	Surge non repetitive forward current	$t_p = 10$ ms Sinusoidal	TO-220AC/TO-220FPAC DPAK	90	A
		$t_p = 10$ ms Sinusoidal		60	
T_{stg}	Storage temperature range		- 65 + 175	°C	
T_j	Maximum operating junction temperature		+ 175	°C	

STTH5L06D/B/FP

THERMAL PARAMETERS

Symbol	Parameter		Maximum	Unit
R _{th(j-c)}	Junction to case	TO-220AC / DPAK	3.5	°C/W
		TO-220FPAC	6.0	

STATIC ELECTRICAL CHARACTERISTICS

Symbol	Parameter	Tests conditions		Min.	Typ.	Max.	Unit
I _R	Reverse leakage current	V _R = 600V	T _j = 25°C			5	μA
			T _j = 150°C		10	125	
V _F	Forward voltage drop	I _F = 5 A	T _j = 25°C			1.3	V
			T _j = 150°C		0.85	1.05	

To evaluate the maximum conduction losses use the following equation :
 $P = 0.89 \times I_{F(AV)} + 0.033 I_{F(RMS)}^2$

DYNAMIC ELECTRICAL CHARACTERISTICS

Symbol	Parameter	Tests conditions		Min.	Typ.	Max.	Unit
t _{rr}	Reverse recovery time	I _F = 1 A dI _F /dt = - 50 A/μs V _R = 30V	T _j = 25°C		65	95	ns
t _{fr}	Forward recovery time	I _F = 5 A dI _F /dt = 100 A/μs V _{FR} = 1.1 x V _{Fmax}	T _j = 25°C			150	ns
V _{FP}	Forward recovery time	I _F = 5 A dI _F /dt = 100 A/μs	T _j = 25°C			7	V

Fig. 1: Conduction losses versus average current.

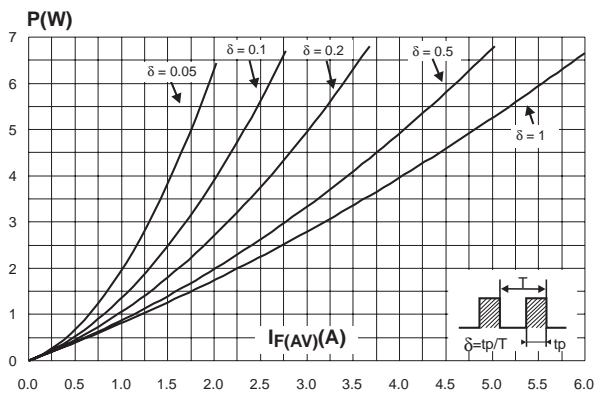

Fig. 2: Forward voltage drop versus forward current.

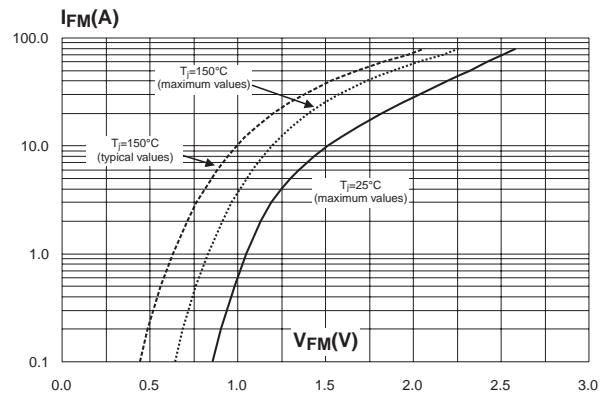

Fig. 3-1: Relative variation of thermal impedance junction to case versus pulse duration (TO-220AC, DPAK).

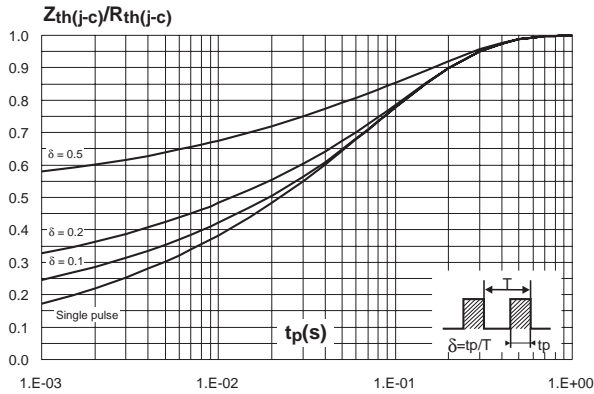

Fig. 3-2: Relative variation of thermal impedance junction to case versus pulse duration (TO-220FPAC).

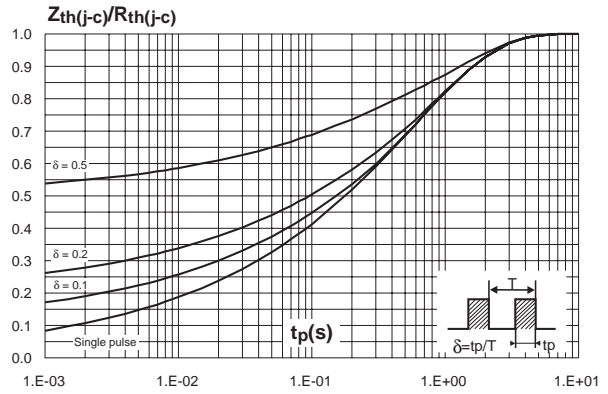

Fig. 4: Peak reverse recovery current versus di_F/dt (90% confidence).

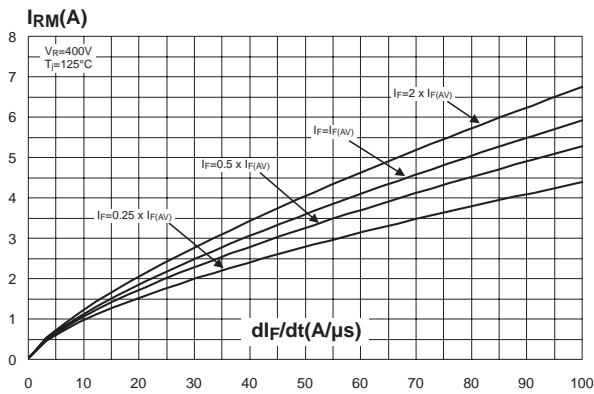

Fig. 5: Reverse recovery time versus di_F/dt (90% confidence).

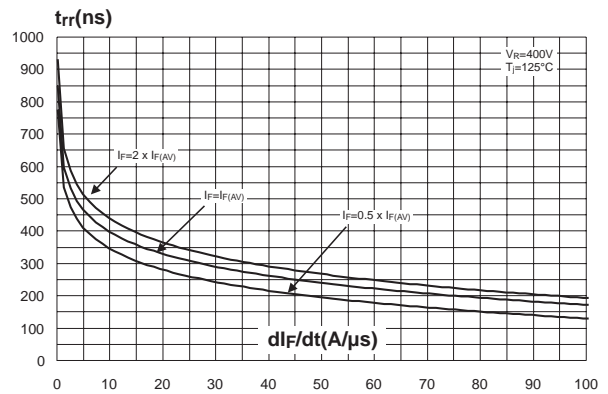

Fig. 6: Reverse recovery charges versus di_F/dt (90% confidence).

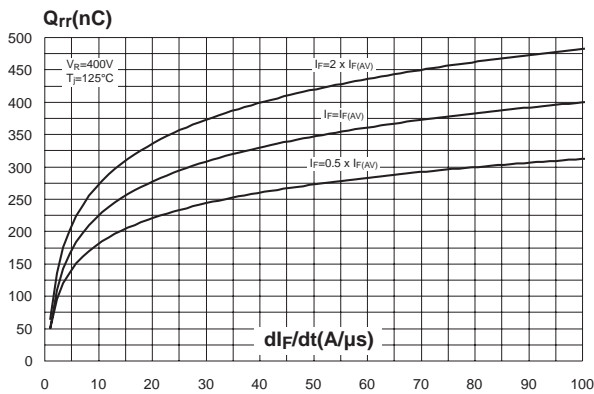
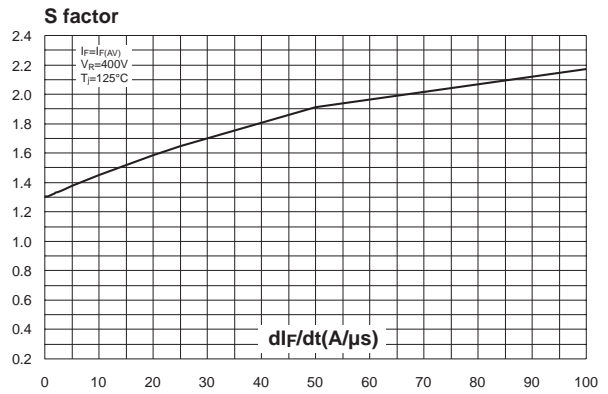

Fig. 7: Softness factor versus di_F/dt (typical values).



STTH5L06D/B/FP

Fig. 8: Relative variations of dynamic parameters versus junction temperature.

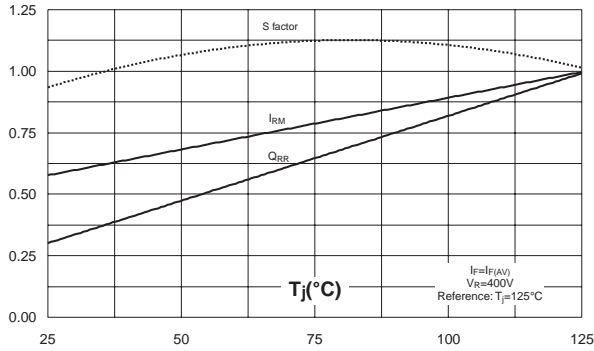

Fig. 9: Transient peak forward voltage versus di_F/dt (90% confidence).

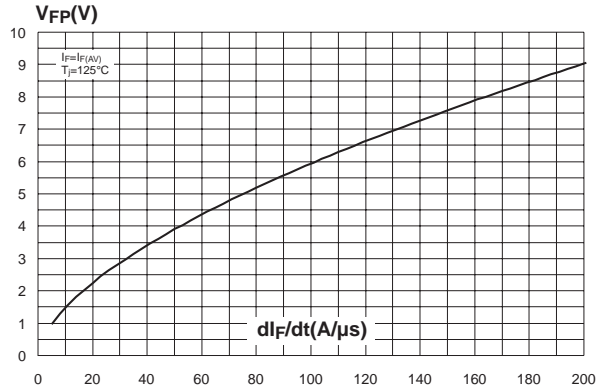

Fig. 10: Forward recovery time versus di_F/dt (90% confidence).

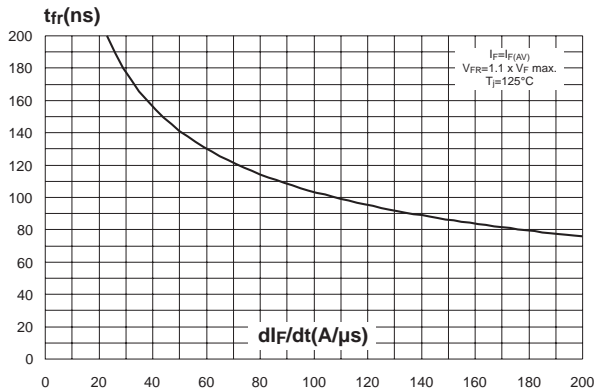

Fig. 11: Junction capacitance versus reverse voltage applied (typical values).

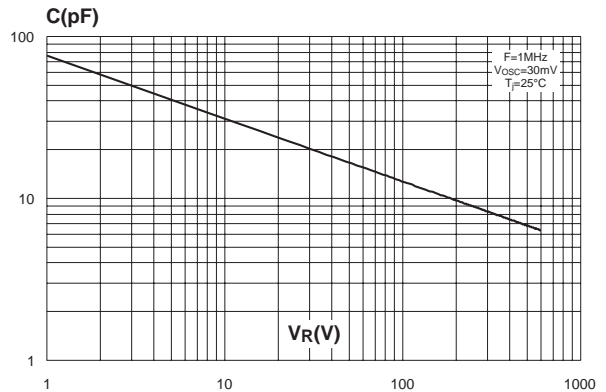
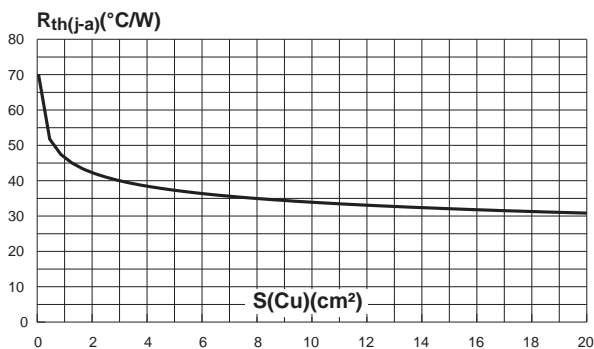
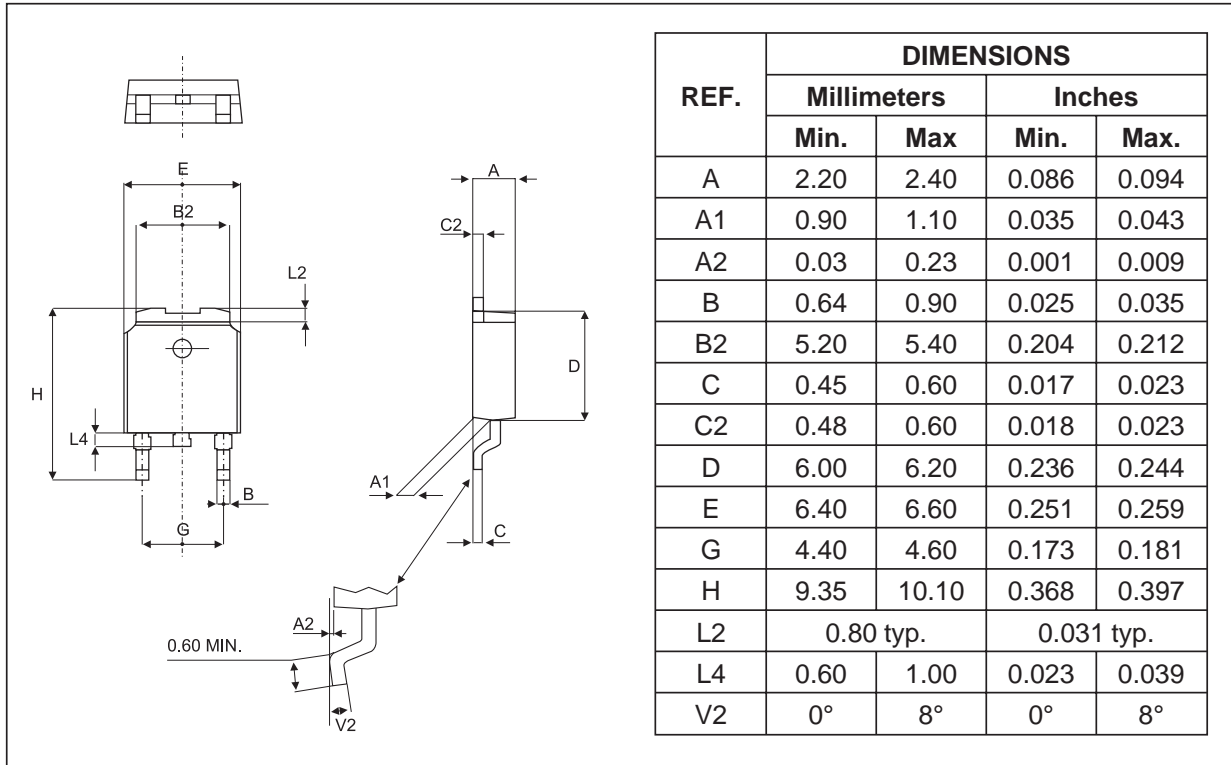

Fig. 12: Thermal resistance junction to ambient versus copper surface under tab (epoxy printed circuit board FR4, copper thickness: 35μm) (DPAK).



PACKAGE MECHANICAL DATA
DPAK



FOOTPRINT

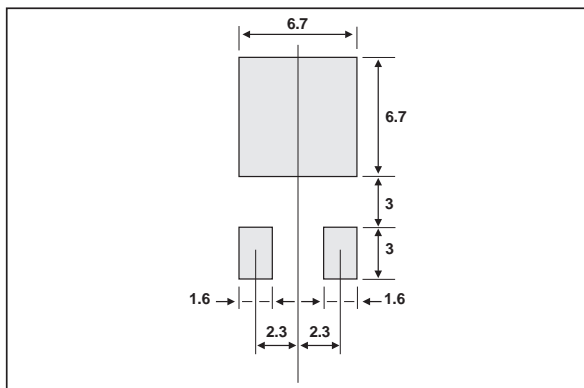

STTH5L06D/B/FP

PACKAGE MECHANICAL DATA TO-220FPAC

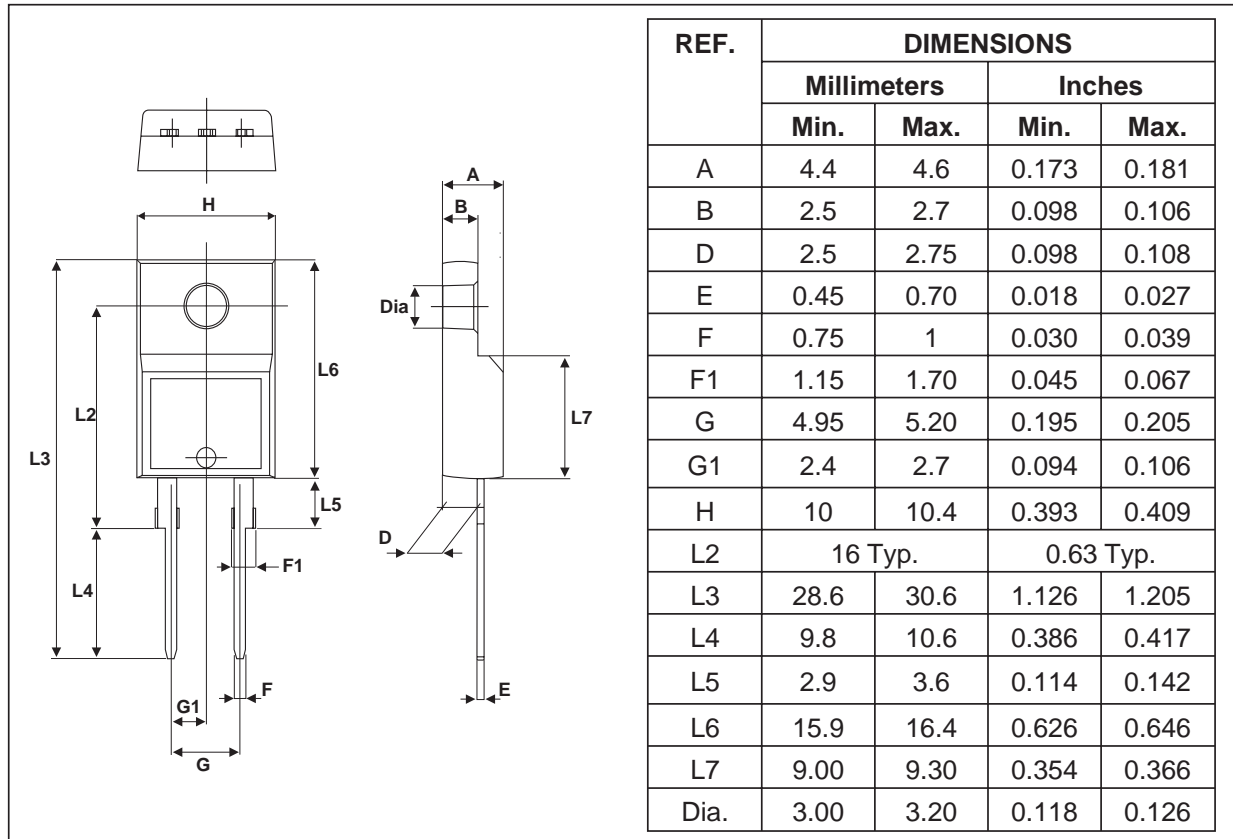

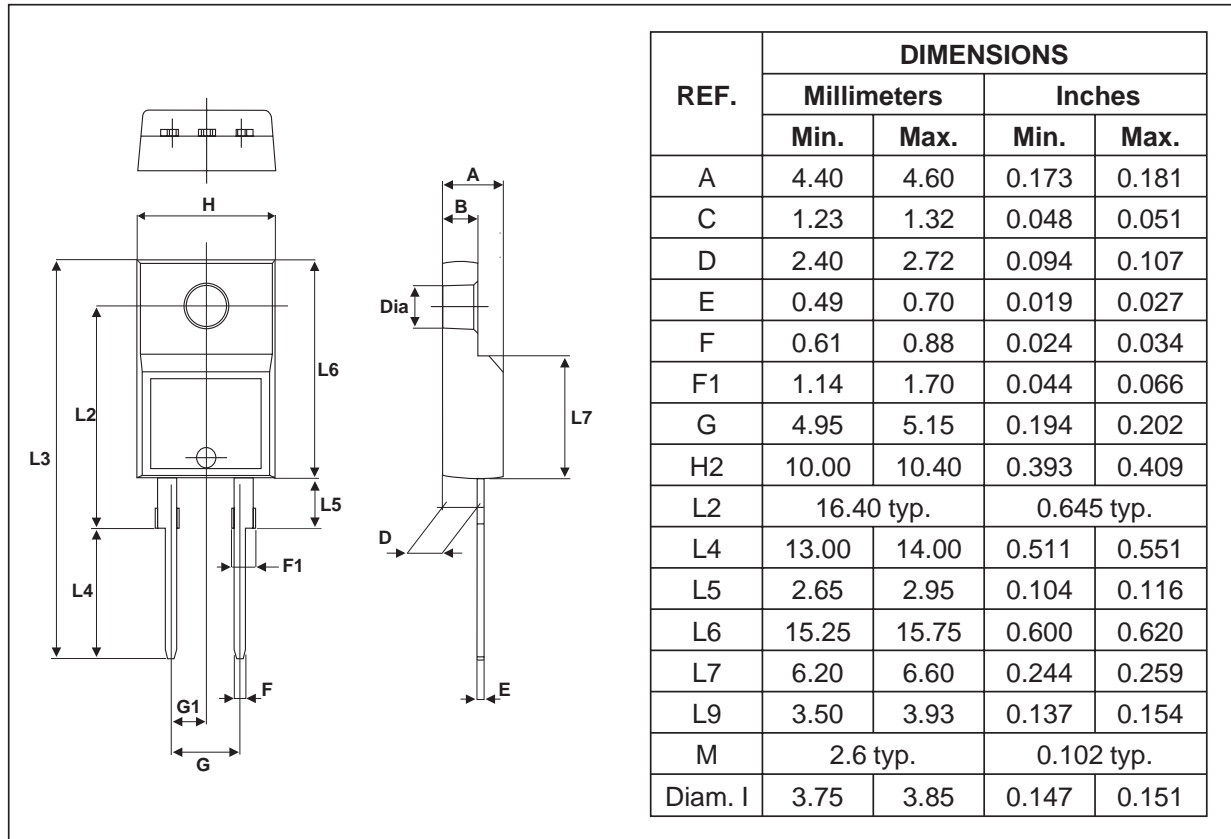
PACKAGE MECHANICAL DATA
 TO-220AC

Ordering code	Marking	Package	Weight	Base qty	Delivery mode
STTH5L06D	STTH5L06D	TO-220AC	1.9 g	50	Tube
STTH5L06B	STTH5L06B	DPAK	0.3 g	75	Tube
STTH5L06B-TR	STTH5L06B	DPAK	0.3 g	2500	Tape & reel
STTH5L06FP	STTH5L06FP	TO-220PFAC	1.7 g	50	Tube

- Epoxy meets UL 94,V0
- Recommended torque value (TO-220AC): 0.55 Nm
- Maximum torque value (TO-220AC / TO-220FPAC): 0.7 Nm

Information furnished is believed to be accurate and reliable. However, STMicroelectronics assumes no responsibility for the consequences of use of such information nor for any infringement of patents or other rights of third parties which may result from its use. No license is granted by implication or otherwise under any patent or patent rights of STMicroelectronics. Specifications mentioned in this publication are subject to change without notice. This publication supersedes and replaces all information previously supplied. STMicroelectronics products are not authorized for use as critical components in life support devices or systems without express written approval of STMicroelectronics.

The ST logo is a registered trademark of STMicroelectronics
 © 2002 STMicroelectronics - Printed in Italy - All rights reserved.
 STMicroelectronics GROUP OF COMPANIES
 Australia - Brazil - Canada - China - Finland - France - Germany
 Hong Kong - India - Israel - Italy - Japan - Malaysia - Malta - Morocco - Singapore
 Spain - Sweden - Switzerland - United Kingdom - United States.

<http://www.st.com>