

# HN462716, HN462716G

## 2048-word × 8-bit UV Erasable and Electrically Programmable Only Memory

The HN462716 is a 2048 word by 8 bit erasable and electrically programmable ROMs. This device is packaged in a 24-pin, dual-in-line package with transparent lid. The transparent lid allows the user to expose the chip to ultraviolet light to erase the bit pattern, whereby a new pattern can then be written into the device.

- Single Power Supply . . . . . +5V ±5%;
- Simple Programming . . . . . Program Voltage: +25V DC  
Programs with One 50ms Pulse
- Static . . . . . No Clocks Required
- Inputs and Outputs TTL Compatible During Both Read and Program Modes
- Fully Decoded-on Chip Address Decode
- Access Time . . . . . 450ns Max.
- Low Power Dissipation . . . . . 555mW Max. Active Power  
213mW Max. Standby Power
- Three State Output . . . . . OR- Tie Capability
- Interchangeable with Intel 2716

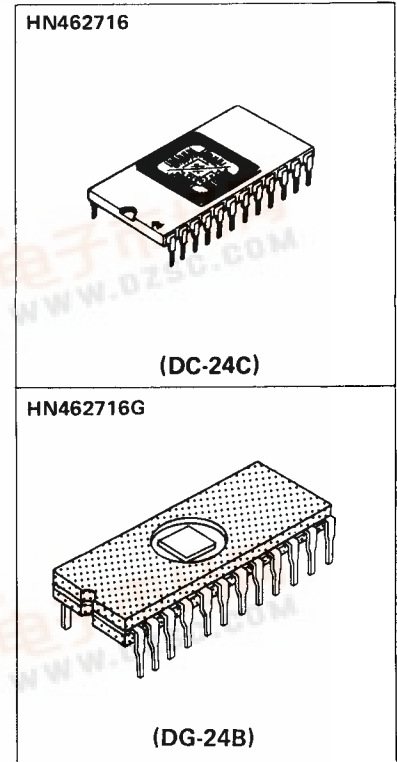

### ■ BLOCK DIAGRAM

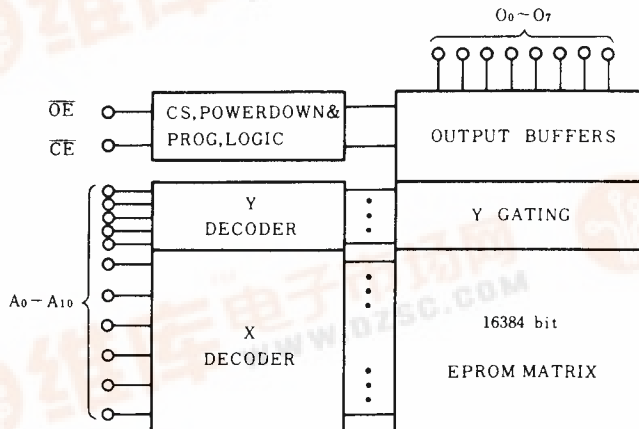

### ■ PIN ARRANGEMENT

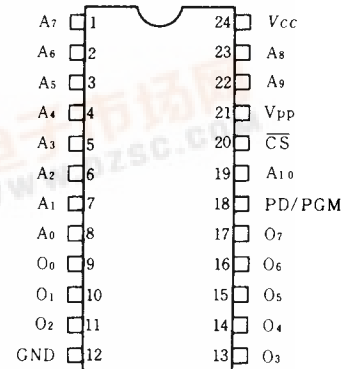

(Top View)

### ■ PROGRAMMING OPERATION

Mode	Pins	$\overline{CE}$ (18)	$\overline{OE}$ (20)	$V_{PP}$ (21)	$V_{CC}$ (24)	Outputs (9~11, 13~17)
Read		$V_{IL}$	$V_{IL}$	+5	+5	Dout
Deselect		Don't Care	$V_{IH}$	+5	+5	High Z
Power Down		$V_{IL}$	Don't Care	+5	+5	High Z
Program		Pulsed $V_{IL}$ to $V_{IH}$	$V_{IH}$	+25	+5	Din
Program Verify		$V_{IL}$	$V_{IL}$	+25	+5	Dout



# HN462716, HN462716G

## ■ ABSOLUTE MAXIMUM RATINGS

Item	Symbol	Value	Unit
Operating Temperature Range	$T_{opr}$	0 to +70	°C
Storage Temperature Range	$T_{stg}$	-65 to +125	°C
All Input and Output Voltages*	$V_{IN}, V_{OUT}$	-0.3 to +7	V
$V_{PP}$ Supply Voltage*	$V_{PP}$	-0.3 to +28	V

\* with respect to Ground

## ■ READ OPERATION

### ● DC AND OPERATING CHARACTERISTICS ( $T_a=0$ to +70°C, $V_{CC}=5V \pm 5\%$ , $V_{PP}=V_{CC} \pm 0.6V$ )

Item	Symbol	Test Condition	min.	typ.	max.	Unit.
Input Leakage Current	$I_{LI}$	$V_{IN} = 5.25V$	—	—	10	$\mu A$
Output Leakage Current	$I_{LO}$	$V_{OUT} = 5.25V/0.4V$	—	—	10	$\mu A$
$V_{PP}$ Current	$I_{PP1}$	$V_{PP} = 5.85V$	—	—	5	mA
$V_{CC}$ Current (Standby)	$I_{CC1}$	$\overline{CE} = V_{IH}, \overline{OE} = V_{IL}$	—	21	35	mA
$V_{CC}$ Current (Active)	$I_{CC2}$	$\overline{OE} = \overline{CE} = V_{IL}$	—	62	100	mA
Input Low Voltage	$V_{IL}$		-0.1	—	0.8	V
Input High Voltage	$V_{IH}$		2.0	—	$V_{CC} + 1$	V
Output Low Voltage	$V_{OL}$	$I_{OL} = 2.1mA$	—	—	0.4	V
Output High Voltage	$V_{OH}$	$I_{OH} = -400\mu A$	2.4	—	—	V

Note:  $V_{CC}$  must be applied simultaneously or before  $V_{PP}$  and removed simultaneously or after  $V_{PP}$ .

### ● AC CHARACTERISTICS ( $T_a=0$ to +70°C, $V_{CC}=5V \pm 5\%$ , $V_{PP}=V_{CC} \pm 0.6V$ )

Parameter	Symbol	Test Conditions	min.	typ.	max.	Unit
Address to Output Delay	$t_{ACC}$	$\overline{OE} = \overline{CE} = V_{IL}$	—	—	450	ns
$\overline{CE}$ to Output Delay	$t_{CE}$	$\overline{OE} = V_{IL}$	—	—	450	ns
$\overline{OE}$ to Output Delay	$t_{OE}$	$\overline{CE} = V_{IL}$	—	—	120	ns
$\overline{OE}$ High to Output Float	$t_{DF}$	$\overline{CE} = V_{IL}$	0	—	100	ns
Address to Output Hold	$t_{OH}$	$\overline{OE} = \overline{CE} = V_{IL}$	0	—	—	ns

### ● CAPACITANCE ( $T_a=25^\circ C$ , $f=1MHz$ )

Item	Symbol	Test Condition	typ.	max.	Unit
Input Capacitance	$C_{in}$	$V_{IN} = 0V$	—	6	pF
Output Capacitance	$C_{out}$	$V_{OUT} = 0V$	—	12	pF

● SWITCHING CHARACTERISTICS

Test Conditions

Input Pulse Levels: 0.8V to 2.2V  
 Input Rise and Fall Times:  $\leq 20$  ns  
 Output Load: 1TTL Gate + 100 pF  
 Reference Level for Measuring Timing:  
 Inputs 1V and 2V  
 Outputs 0.8V and 2V

READ MODE ( $\overline{OE} = V_{IL}$ )

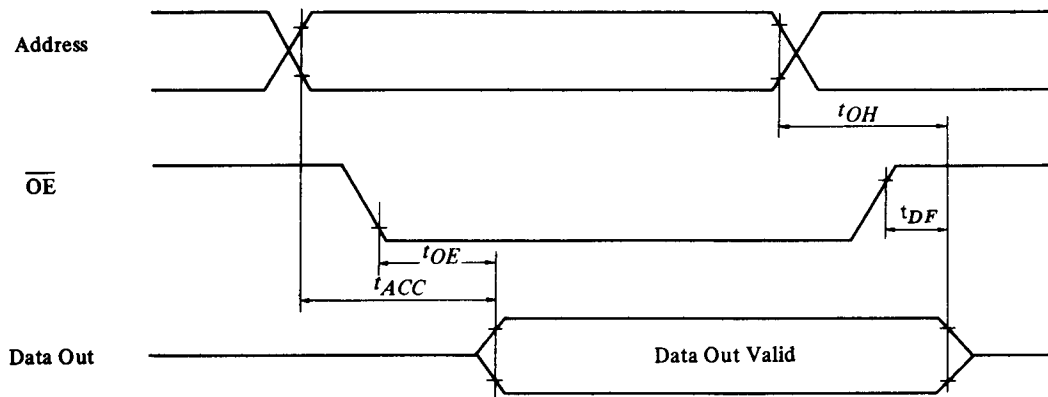

STANDBY MODE ( $\overline{OE} = V_{IL}$ )

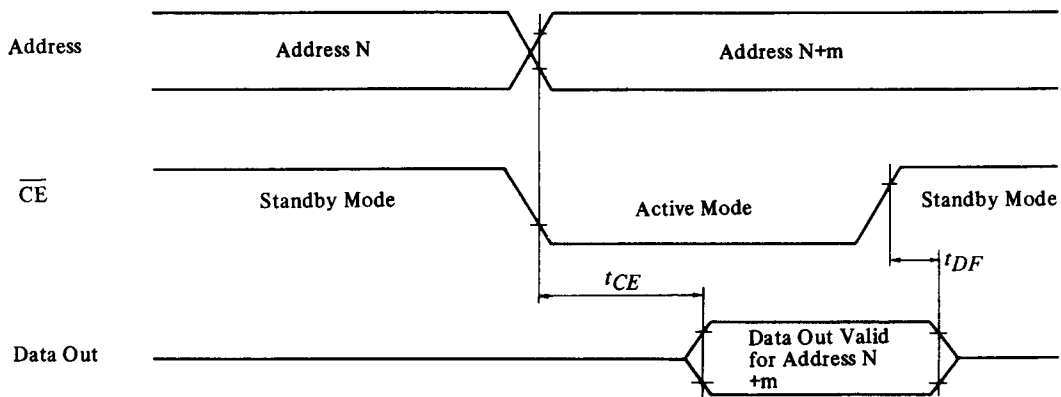

● TYPICAL CHARACTERISTICS

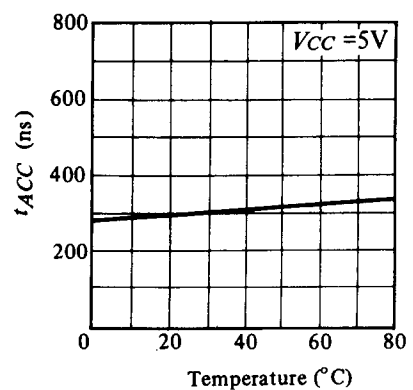
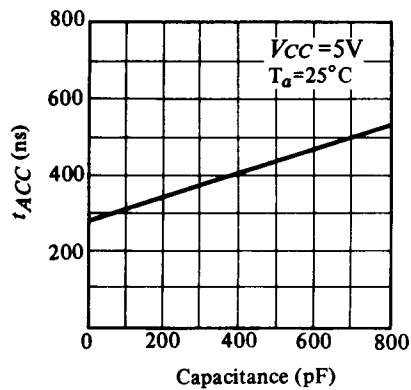
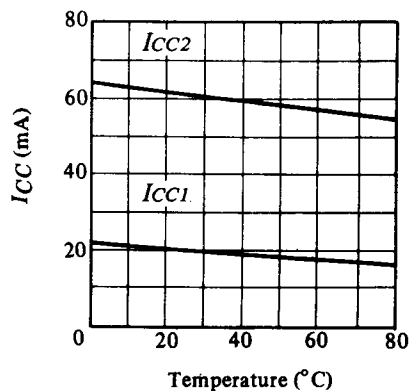

# HN462716, HN462716G

## • D.C. PROGRAMMING CHARACTERISTICS ( $T_a=25^\circ\text{C} \pm 5^\circ\text{C}$ , $V_{CC}=5\text{V} \pm 5\%$ , $V_{PP}=25\text{V} \pm 1\text{V}$ )

Parameter	Symbol	Test Conditions	min.	typ.	max.	Unit
Input Leakage Current	$I_{LI}$	$V_{CC}=5.25\text{V}/0.4\text{V}$	—	—	10	$\mu\text{A}$
$V_{PP}$ Supply Current	$I_{PP1}$	$\overline{\text{CE}}=V_{IL}$	—	—	6	mA
$V_{PP}$ Supply Current During Programming	$I_{PP2}$	$\overline{\text{CE}}=V_{IH}$	—	—	30	mA
$V_{CC}$ Supply Current	$I_{CC}$		—	—	100	mA
Input Low Level	$V_{IL}$		-0.1	—	0.8	V
Input High Level	$V_{IH}$		2.0	—	$V_{CC}+1$	V

## • A.C. PROGRAMMING CHARACTERISTICS ( $T_a=25^\circ\text{C} \pm 5^\circ\text{C}$ , $V_{CC}=5\text{V} \pm 5\%$ , $V_{PP}=25\text{V} \pm 1\text{V}$ )

Parameter	Symbol	Test Conditions	min.	typ.	max.	Unit
Address Setup Time	$t_{AS}$		2	—	—	$\mu\text{s}$
$\overline{\text{OE}}$ Setup Time	$t_{OES}$		2	—	—	$\mu\text{s}$
Data Setup Time	$t_{DS}$		2	—	—	$\mu\text{s}$
Address Hold Time	$t_{AH}$		2	—	—	$\mu\text{s}$
$\overline{\text{OE}}$ Hold Time	$t_{OEH}$		5	—	—	$\mu\text{s}$
Data Hold Time	$t_{DH}$		2	—	—	$\mu\text{s}$
$\overline{\text{OE}}$ to Output Float Delay	$t_{DF}$	$\overline{\text{CE}}=V_{IL}$	0	—	120	ns
$\overline{\text{OE}}$ to Output Delay	$t_{OE}$	$\overline{\text{CE}}=V_{IL}$	—	—	120	ns
Program Pulse Width	$t_{PW}$		45	50	55	ms
Program Pulse Rise Time	$t_{PRT}$		5	—	—	ns
Program Pulse Fall Time	$t_{PFT}$		5	—	—	ns

Note:  $V_{CC}$  must be applied simultaneously or before  $V_{PP}$  and removed simultaneously or after  $V_{PP}$ .

## • SWITCHING CHARACTERISTICS

Test Conditions

Input Pulse Level: 0.8V to 2.2V

Input Rise and Fall Times:  $\leq 20$  ns

Output Load: 1 TTL Gate + 100 pF

Reference Level for Measuring Timing:

Inputs; 1V and 2V, Outputs; 0.8V and 2V

## • PROGRAMMING WAVEFORMS

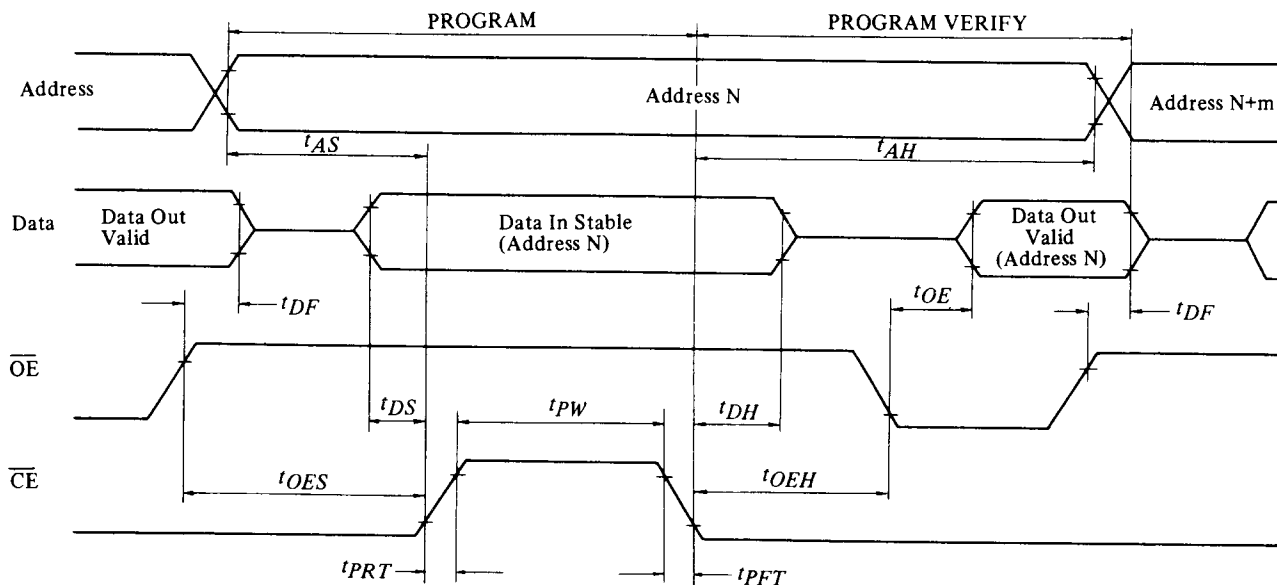

**● ERASE**

Erasure of HN462716 is performed by exposure to ultraviolet light with a wavelength of 2537Å, and all the output data are changed to "1" after this erasure procedure.

The minimum integrated dose (i.e., UV intensity x exposure time) for erasure is  $15W \cdot \text{sec}/\text{cm}^2$ .

**■ DEVICE OPERATION****● READ MODE**

Dataout is available 450 ns ( $t_{ACC}$ ) from addresses with  $\overline{OE}$  low or 120 ns ( $t_{OE}$ ) from  $\overline{OE}$  with addresses stable.

**● DESELECT MODE**

The outputs may be OR-tied together with the other HN462716s. When HN462716s are deselected, the  $\overline{OE}$  inputs must be at high TTL level.

**● POWER DOWN MODE**

Power down is achieved with  $\overline{CE}$  high TTL level. In this mode the outputs are in a high impedance state.

**● PROGRAMMING**

Initially, and after each erasure, all bits of the HN462716 are in the "high" state (Output High). Data is introduced by selectively programming "low" into the desired bit locations. In the programming mode,  $V_{pp}$  power supply is at 25V and  $\overline{OE}$  input is at high TTL level. Data to be programmed are presented 8-bits in parallel, to the data output lines (O1 to O8).

The addresses and inputs are at TTL levels.

After the address and data setup, a 50 ms, active high program pulse is applied to the  $\overline{CE}$  input. The  $\overline{CE}$  is at TTL level.

The HN462716 must not be programmed with a DC signal applied to the  $\overline{CE}$  input.

**● PROGRAM VERIFY**

The HN462716 has a program verify mode. A verify should be performed on the programmed bits to determine that they were correctly programmed. In this mode  $V_{pp}$  is at 25V.

**● PROGRAM INHIBIT**

Programming of multiple HN462716s in parallel with different data is easily accomplished by using this mode. Except for  $\overline{CE}$ , all like inputs of the parallel HN462716s may be common.

A TTL program pulse applied to 0 HN462716's  $\overline{CE}$  input will program that HN462716. A low level  $\overline{CE}$  inhibits the other HN462716s from being programmed.