

Monolithic Linear IC

LA6523

SANYO

3-Output Power Operational Amplifier

Overview

The LA6523 is a 3-output power operational amplifier IC developed for widespread use in consumer and industrial applications.

Package Dimensions

unit : mm

3022A-DIP12F

Features and Functions

- High output current ($I_o \text{ max} = 0.5 \text{ A}$)
- High gain
- Current limiter
- Wide operating supply voltage (± 2 to $\pm 18 \text{ V}$)
- Single supply operation possible (4 to 36 V)
- Mute circuit (active low)
- Thermal shutdown circuit built-in

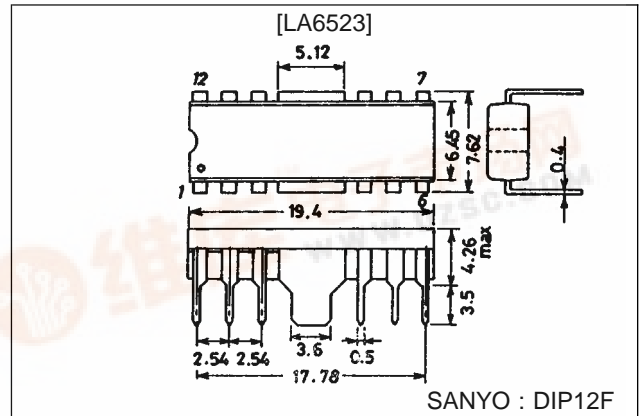

Specifications

Maximum Ratings at $T_a = 25^\circ\text{C}$

Parameter	Symbol	Conditions	Ratings	Unit
Maximum supply voltage	V_{CC}/V_{EE}		± 18	V
Differential input voltage	V_{ID}		30	V
Input common-mode voltage	V_{IN}		± 15	V
Allowable power dissipation	$P_d \text{ max}$		1.9	W
Operating temperature	T_{opr}		-20 to $+75$	$^\circ\text{C}$
Storage temperature	T_{stg}		-55 to $+150$	$^\circ\text{C}$

Operating Condition at $T_a = 25^\circ\text{C}$

Parameter	Symbol	Conditions	Ratings	Unit
Recommended operating supply voltage	V_{CC}/V_{EE}		± 2 to ± 16	V

LA6523

Electrical Characteristics at $T_a = 25^\circ\text{C}$, $V_{CC}/V_{EE} = \pm 15\text{ V}$

Parameter	Symbol	Conditions	min	typ	max	Unit
No-load current drain 1	I_{CC1}		8	20	32	mA
No-load current drain 2	I_{CC2}	Mute On		6.5	16.5	mA
Input offset voltage	V_{IO}	$R_s \leq 10\text{ k}\Omega$		2	7	mV
Input offset current	I_{IO}			10	100	nA
Input bias current	I_B			50	300	nA
Input common-mode voltage range	V_{ICM}		-15		+13	V
Common-mode signal rejection ratio	CMR		65	80		dB
Maximum output voltage	V_O	$R_L = 32\ \Omega$	± 11	± 12		V
Voltage gain	V_{G_O}			85		dB
Slew rate	SR	$G_V = 0$, $R_L = 32\ \Omega$, $R = 10\ \Omega$, $C = 0.1\ \mu\text{F}$		0.15		V/ μs
Supply voltage rejection ratio	SVR			30	300	$\mu\text{V/V}$
Limiter current (built-in type)	I_{SC}			0.5		A
Mute ON voltage	V_{MON}		0.3	1.0		V
Mute pin output current	I_{Mute}	$V_{Mref} = V_{Mute} = 0\text{ V}$		10	50	μA

Pin Assignment

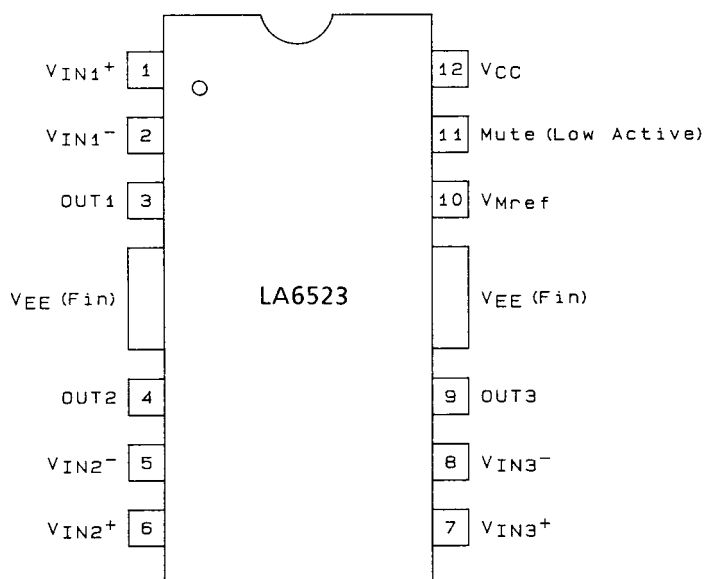

DIP-12F

Top view

A02944

LA6523

Test Circuit

(1) V_{I0} , SVRR

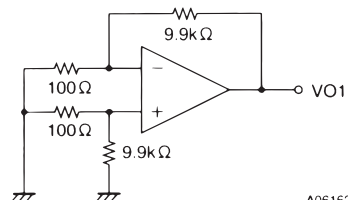

$$V_{I0} = V_{CC} / V_{EE} = \pm 15V$$

$$V_{I0} = V_{O1} / 100$$

$$SVRR \left[\begin{array}{l} V_{CC} = 15V, 5V \\ V_{EE} = -5V, -15V \end{array} \right. \left. \begin{array}{l} SVR(+) \\ SVR(-) \end{array} \right] = \left| \frac{\Delta V_{O1}}{100 \times 10V} \right|$$

(2) V_O

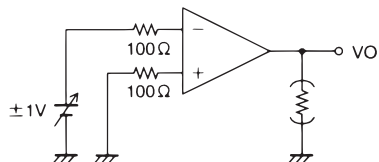

(3) CMRR, V_{ICM}

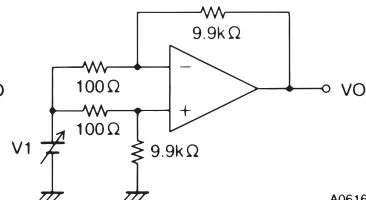

$$CMRR \quad V1 = \pm 7.5V$$

$$CMR = 20 \log \frac{15 \times 100}{|\Delta V_O|}$$

(4) $I_B (-)$

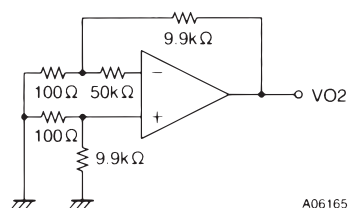

$$I_B(-) = \frac{|V_{O2} - V_{O1}|}{50k\Omega \times 100}$$

(5) $I_B (+)$

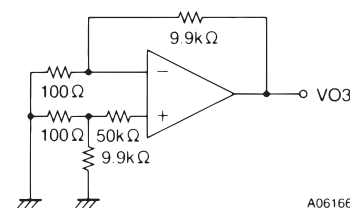

$$I_B(+) = \frac{|V_{O3} - V_{O1}|}{50k\Omega \times 100}$$

(6) I_{I0}

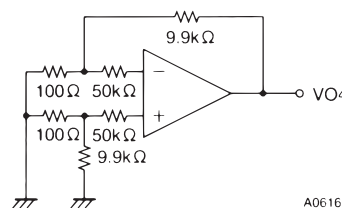

$$I_{I0} = \frac{|V_{O4} - V_{O1}|}{50k\Omega \times 100}$$

(7) I_{CC}

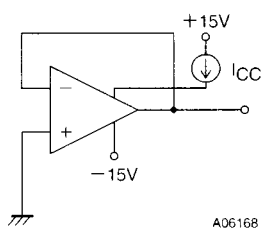

(8) SR

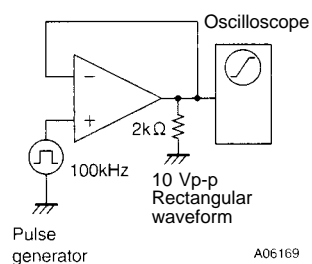

(9) V_{G0}

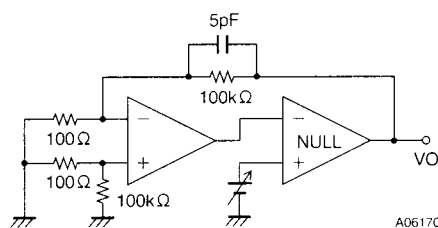

$$V_{G0} = 20 \log \frac{1000 \times 20}{\Delta V_O}$$

LA6523

(10) V_{MON}

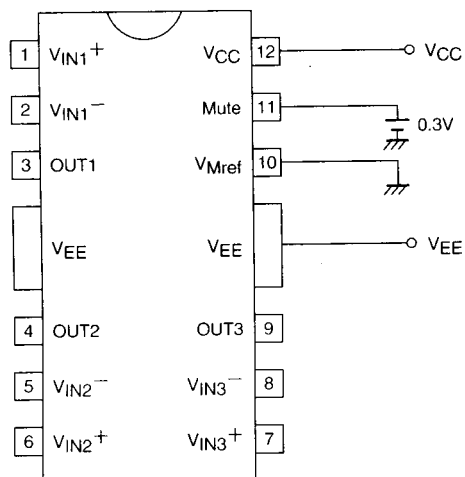

When $V_{Mref} = 0$ [V], $V_{Mute} = 0.3$ [V], output is not turned on.

A06171

(11) I_{Mute}

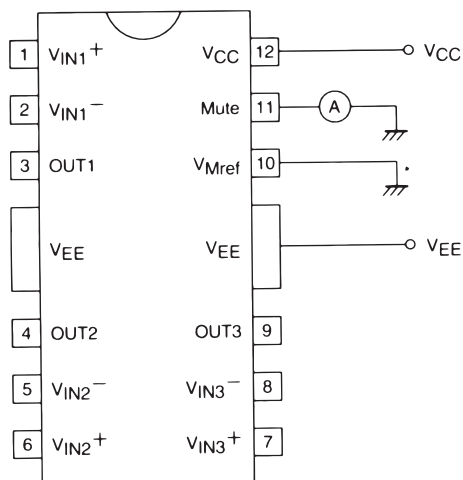

Out-flow current when $V_{Mref} = V_{Mute} = 0$ [V]

A06172

- No products described or contained herein are intended for use in surgical implants, life-support systems, aerospace equipment, nuclear power control systems, vehicles, disaster/crime-prevention equipment and the like, the failure of which may directly or indirectly cause injury, death or property loss.
- Anyone purchasing any products described or contained herein for an above-mentioned use shall:
 - ① Accept full responsibility and indemnify and defend SANYO ELECTRIC CO., LTD., its affiliates, subsidiaries and distributors and all their officers and employees, jointly and severally, against any and all claims and litigation and all damages, cost and expenses associated with such use:
 - ② Not impose any responsibility for any fault or negligence which may be cited in any such claim or litigation on SANYO ELECTRIC CO., LTD., its affiliates, subsidiaries and distributors or any of their officers and employees jointly or severally.
- Information (including circuit diagrams and circuit parameters) herein is for example only; it is not guaranteed for volume production. SANYO believes information herein is accurate and reliable, but no guarantees are made or implied regarding its use or any infringements of intellectual property rights or other rights of third parties.