

TOSHIBA

INTEGRATED GTR MODULE

MIG20J901H

Unit in mm

High Power Switching Applications

Motor Control Applications

- Integrates Inverter, Converter and Brake Power Circuits in One Package.
- Output (Inverter Stage)
 - : 3 ϕ 20A/600V High Speed Type IGBT
 - $V_{CE(sat)}$ = 4.00V (Max.)
 - t_f = 0.30 μ s (Max.)
 - t_{rr} = 0.15 μ s (Max.)
- Input (Converter Stage)
 - : 3 ϕ 20A/800V Silicon Rectifier
 - V_F = 1.20V (Max.)
- Brake Stage
 - : 15A/600V IGBT & 15A/600V FRD
- The Electrodes are Isolated from Case.

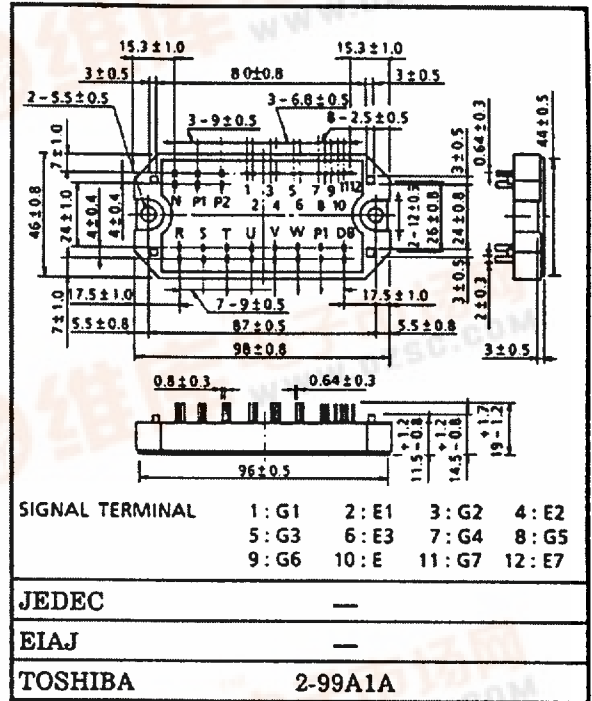

Equivalent Circuit

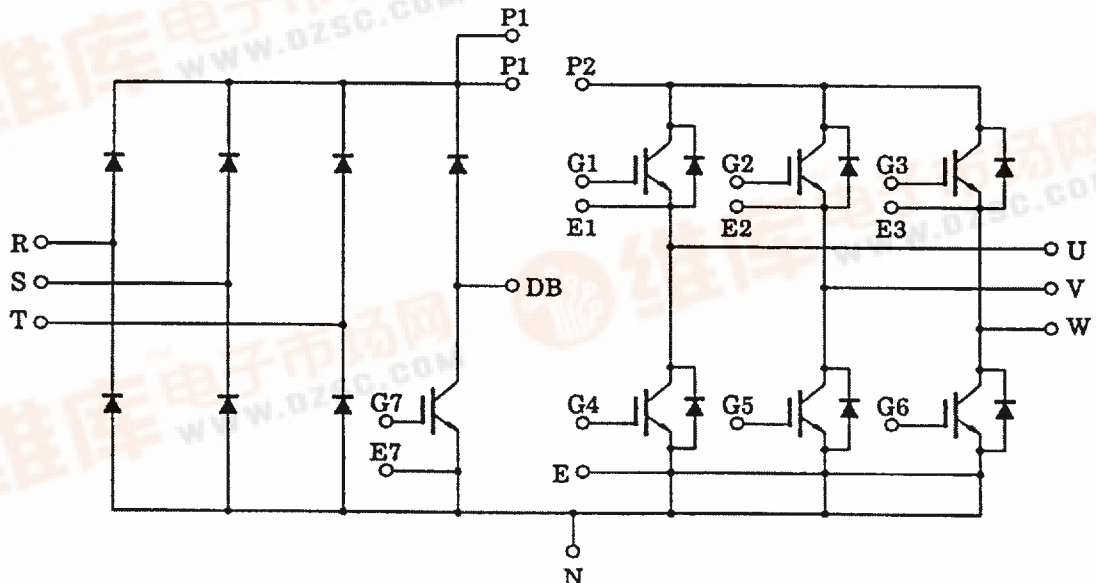

MIG20J901H

Maximum Ratings (Ta = 25°C)

STAGE		CHARACTERISTIC		SYMBOL	RATINGS	UNIT
Inverter		Collector-Emitter Voltage		V_{CES}	600	V
		Gate-Emitter Voltage		V_{GES}	±20	V
		Collector Current	DC	I_C	20	A
			1ms	I_{CP}	40	
		Forward Current	DC	I_F	20	A
			1ms	I_{FM}	40	
Collector Power Dissipation (Tc = 25°C)		P_C	80	W		
Converter		Repetitive Peak Reverse Voltage		V_{RRM}	800	V
		Average Output Rectified Current		I_O	20	A
		Peak One Cycle Surge Forward Current (50Hz, Non-Repetitive)		I_{FSM}	250	A
Brake	IGBT	Collector-Emitter Voltage		V_{CES}	600	V
		Gate-Emitter Voltage		V_{GES}	±20	V
		Collector Current	DC	I_C	15	A
			1ms	I_{CP}	30	
	Collector Power Dissipation (Tc = 25°C)		P_C	65	W	
	FRD	Repetitive Peak Reverse Voltage		V_{RRM}	600	V
		Forward Current	DC	I_F	15	A
			1ms	I_{FM}	30	
Junction Temperature		T_j	150	°C		
Storage Temperature Range		T_{stg}	-40 ~ 125	°C		
Isolation Voltage		V_{isol}	2500 (AC 1 minute)	V		
Screw Torque		—	3	N•m		

Electrical Characteristics (Ta = 25°C)

a. Inverter Stage

CHARACTERISTIC		SYMBOL	TEST CONDITION	MIN.	TYP.	MX.	UNIT
Gate Leakage Current		I_{GES}	$V_{GE} = \pm 20V, V_{CE} = 0$	-	-	± 20	μA
Collector Cut-off Current		I_{CES}	$V_{CE} = 600V, V_{GE} = 0$	-	-	1.0	mA
Gate-Emitter Cut-off Voltage		$V_{GE (off)}$	$V_{CE} = 5V, I_C = 20mA$	3.0	-	6.0	V
Collector-Emitter Saturation Voltage		$V_{CE (sat)}$	$I_C = 20A, V_{GE} = 15V$	-	3.0	4.0	V
Input Capacitance		C_{ies}	$V_{CE} = 10V, V_{GE} = 0$ $f = 1MHz$	-	1300	-	pF
Switching Time	Turn-on Delay Time	$t_{d(on)}$	Inductive Load $V_{CC} = 300V$ $I_C = 20A$ $V_{GE} = \pm 15V$ $R_G = 120\Omega$ (Note 1)	-	0.08	0.16	μs
	Rise Time	t_r		-	0.12	0.24	
	Turn-on Time	t_{on}		-	0.40	0.80	
	Turn-off Delay Time	$t_{d(off)}$		-	0.30	0.60	
	Fall Time	t_f		-	0.15	0.30	
	Turn-off Time	t_{off}		-	0.60	1.00	
Forward Voltage		V_F	$I_F = 20A, V_{GE} = 0$	-	1.7	2.5	V
Reverse Recovery Time		t_{rr}	$I_F = 20A, V_{GE} = -10V$ $di/dt = 50A/\mu s$	-	0.08	0.15	μs
Thermal Resistance		$R_{th(j-c)}$	Transistor	-	-	1.56	$^{\circ}C/W$
			Diode	-	-	2.80	

b. Converter Stage

CHARACTERISTIC	SYMBOL	TEST CONDITION	MIN.	TYP.	MX.	UNIT
Repetitive Peak Reverse Current	I_{RRM}	$V_{RRM} = 800V$	-	-	50	μA
Peak Forward Voltage	V_{FM}	$I_{FM} = 20A$	-	1.05	1.20	V
Peak One Cycle Surge Forward Current	I_{FSM}	50Hz Sine-half-wave	250	-	-	A
Thermal Resistance	$R_{th(j-c)}$	-	-	-	2.50	$^{\circ}C/W$

MIG20J901H

c. Brake Stage

CHARACTERISTIC		SYMBOL	TEST CONDITION	MIN.	TYP.	MX.	UNIT
Gate Leakage Current		I_{GES}	$V_{GE} = \pm 20V, V_{CE} = 0$	-	-	± 20	μA
Collector Cut-off Current		I_{CES}	$V_{CE} = 600V, V_{GE} = 0$	-	-	1.0	mA
Repetitive Peak Reverse Current		I_{RRM}	$V_{RRM} = 600V$	-	-	1.0	mA
Gate-Emitter Cut-off Voltage		$V_{GE(off)}$	$V_{CE} = 5V, I_C = 15mA$	3.0	-	6.0	V
Collector-Emitter Saturation Voltage		$V_{CE(sat)}$	$I_C = 15A, V_{GE} = 15V$	-	3.0	4.0	V
Input Capacitance		C_{ies}	$V_{CE} = 10V, V_{GE} = 0$ $f = 1MHz$	-	1000	-	pF
Switching Time	Turn-on Delay Time	$t_{d(on)}$	Inductive Load	-	0.08	0.16	μs
	Rise Time	t_r	$V_{CC} = 300V$	-	0.12	0.24	
	Turn-on Time	t_{on}	$I_C = 15A$	-	0.40	0.80	
	Turn-off Delay Time	$t_{d(off)}$	$V_{GE} = \pm 15V$	-	0.30	0.60	
	Fall Time	t_f	$R_G = 150\Omega$	-	0.30	0.55	
	Turn-off Time	t_{off}	(Note 1)	-	0.65	1.00	
Forward Voltage		V_F	$I_F = 15A, V_{GE} = 0$	-	1.7	2.5	V
Thermal Resistance		$R_{th(j-c)}$	Transistor	-	-	1.92	$^{\circ}C/W$
			Diode	-	-	2.80	

Note. 1 Switching Time Test Circuit & Timing Chart

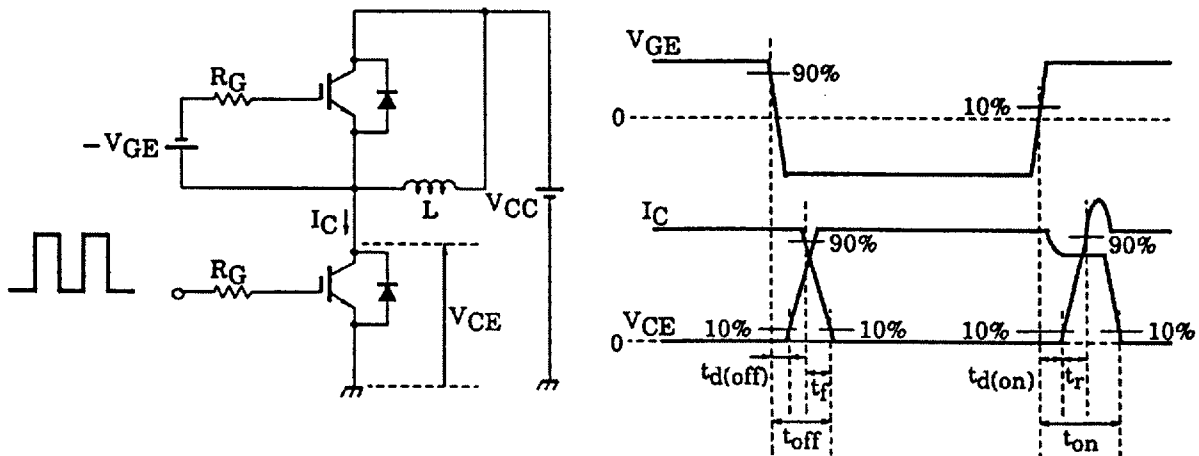

a. Inverter Stage

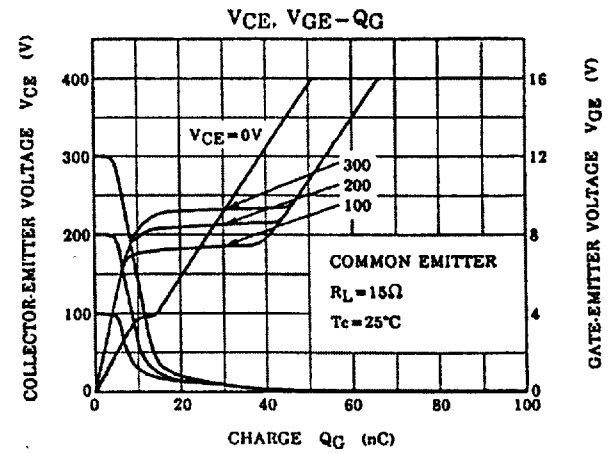
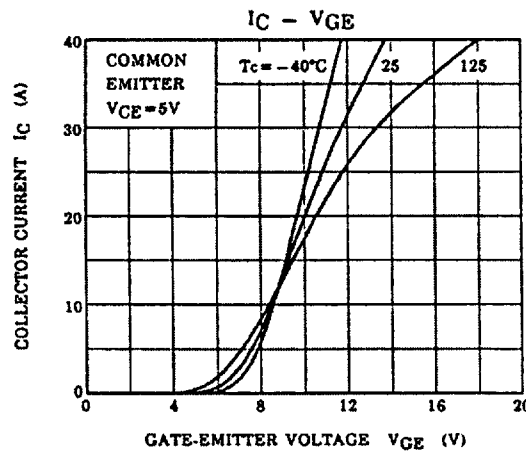
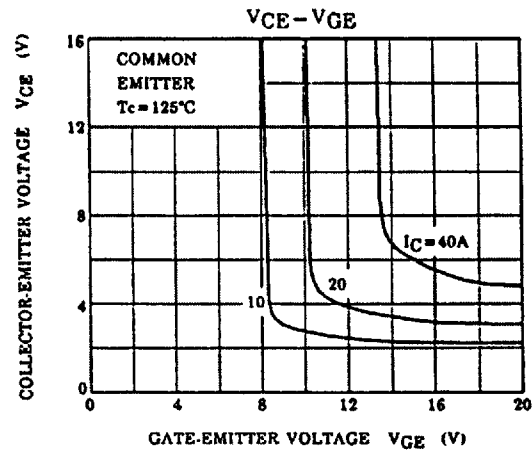
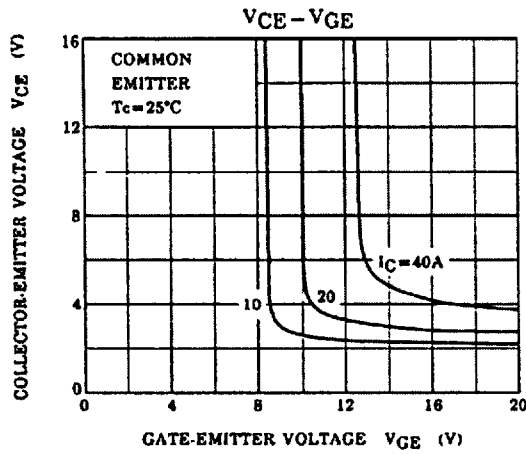
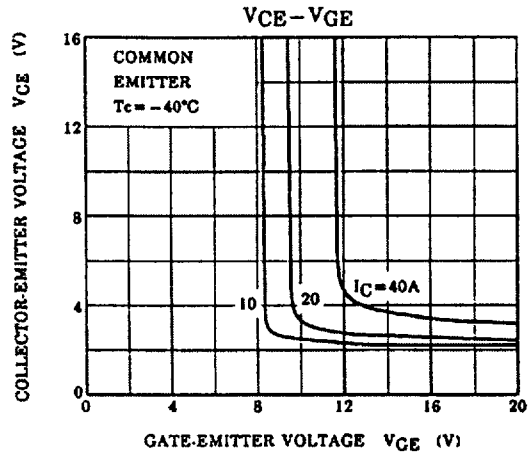
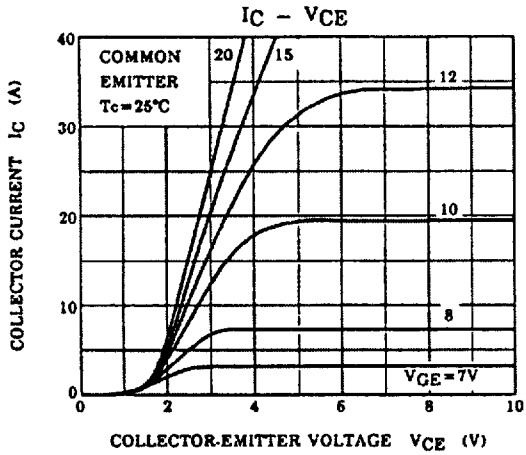

MIG20J901H

a. Inverter Stage

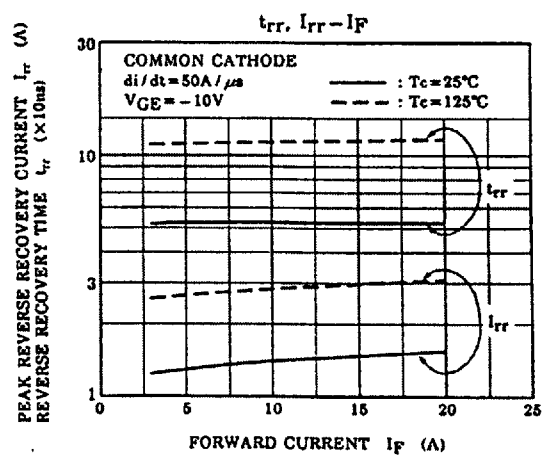
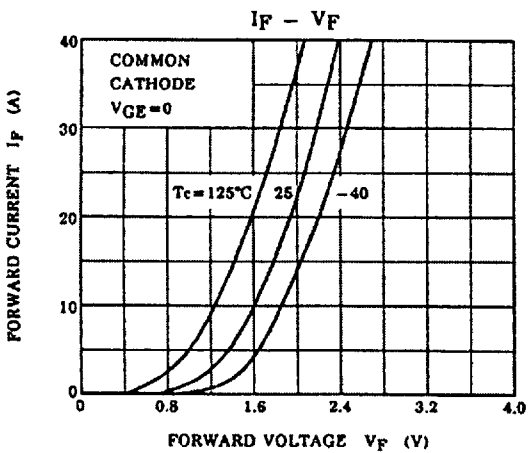
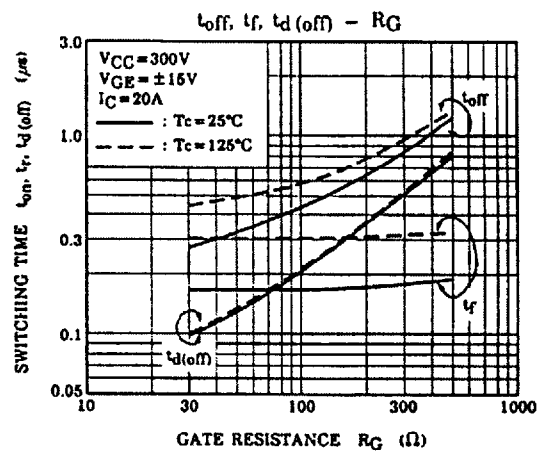
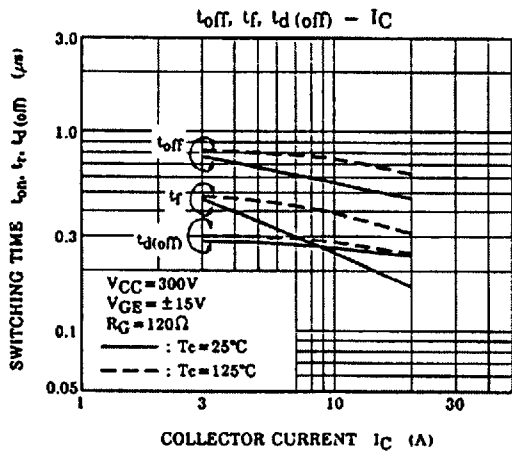
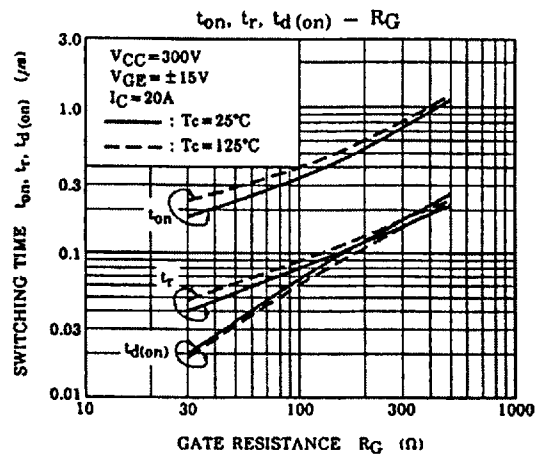
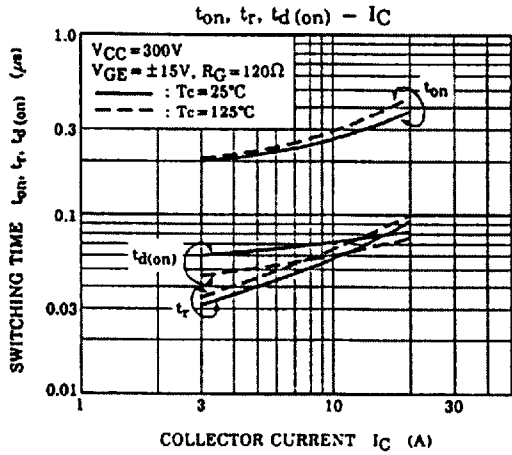

a. Inverter Stage

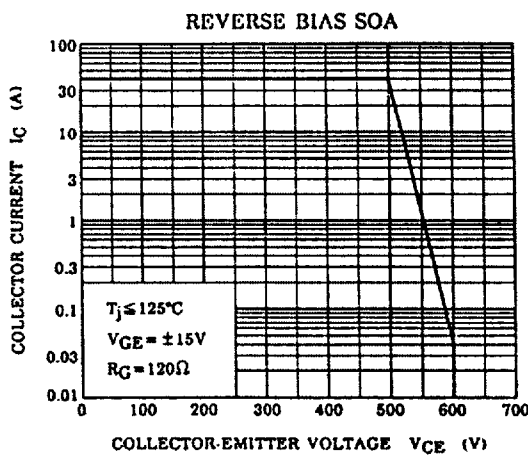
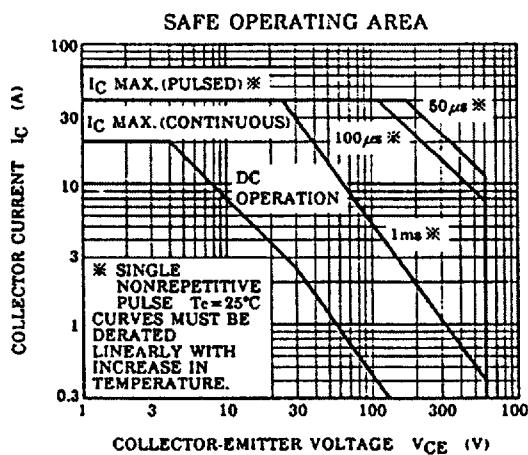
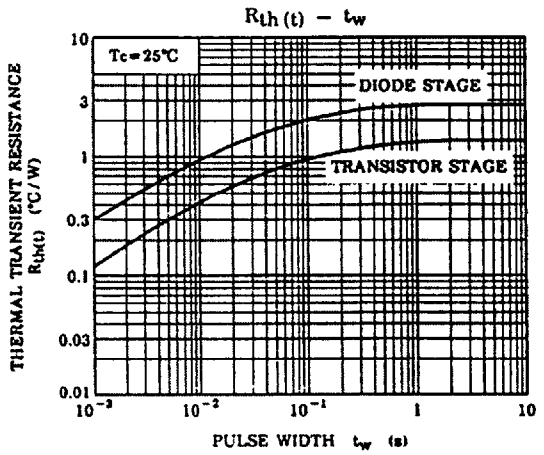
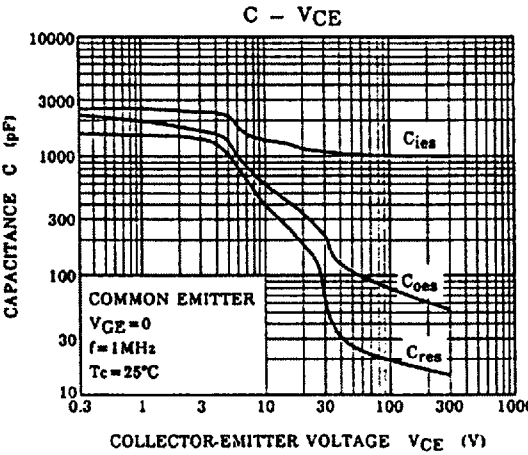

MIG20J901H

b. Converter Stage

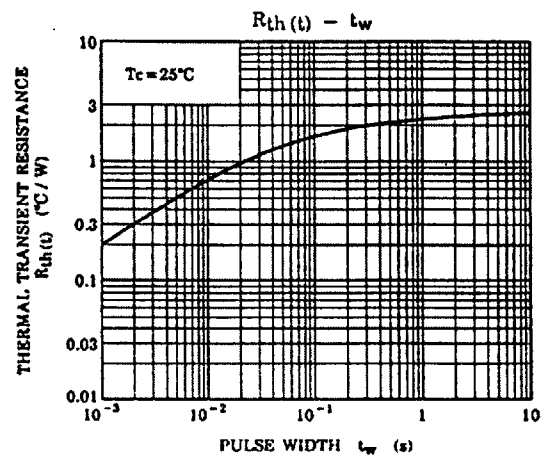
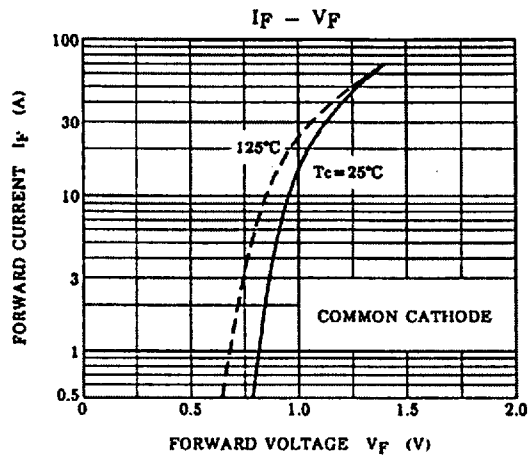

c. Brake Stage

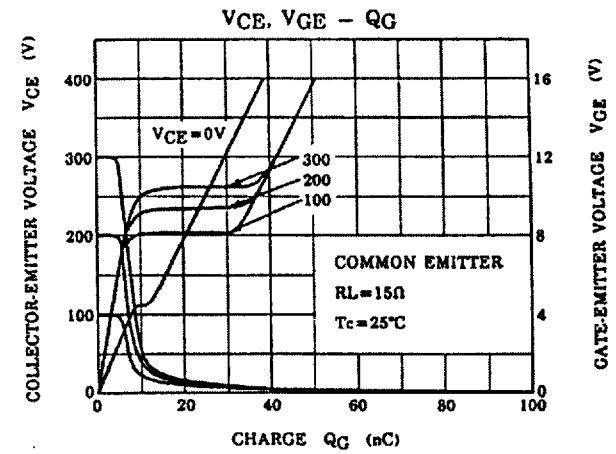
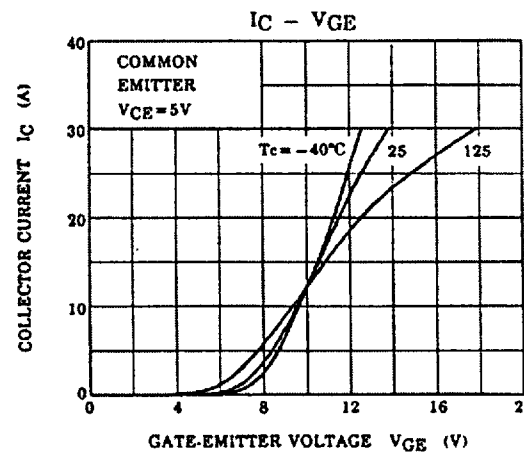
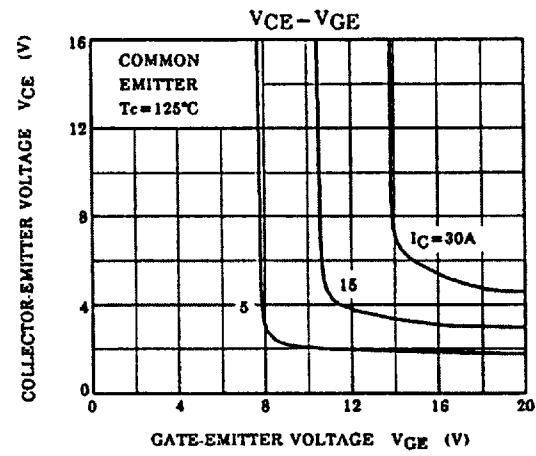
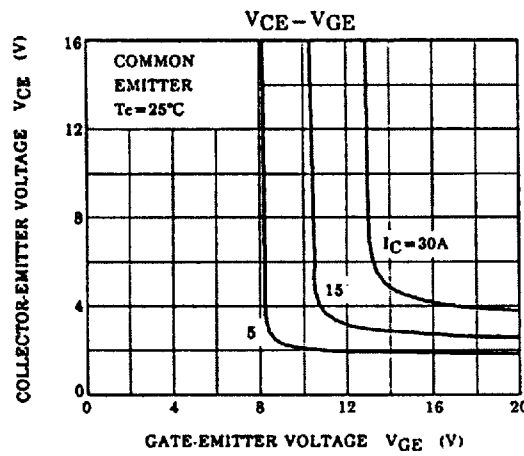
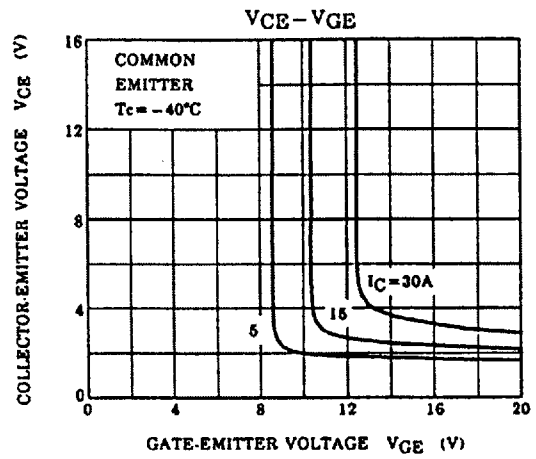
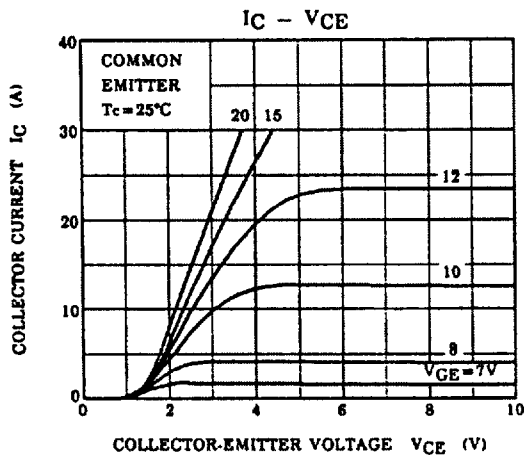

MIG20J901H

c. Brake Stage

(MIG20J901H)

c. Brake Stage

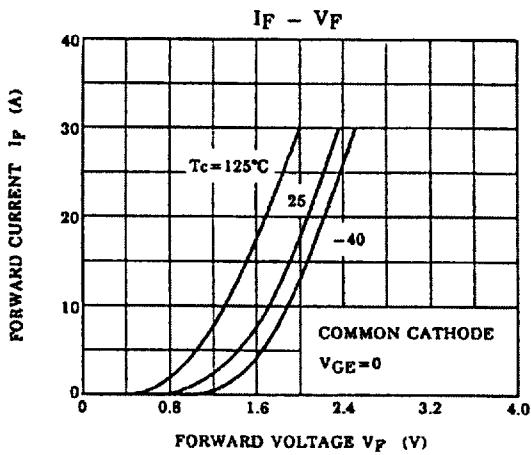
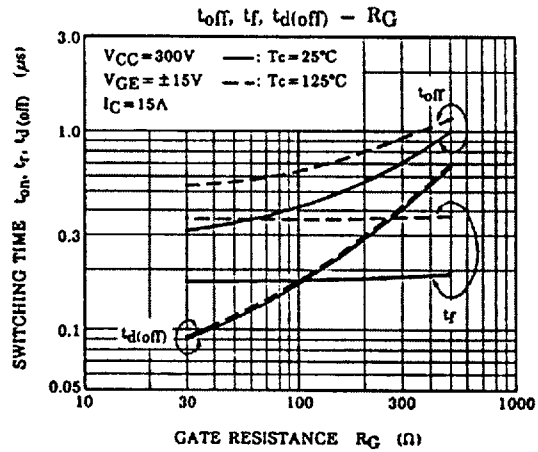
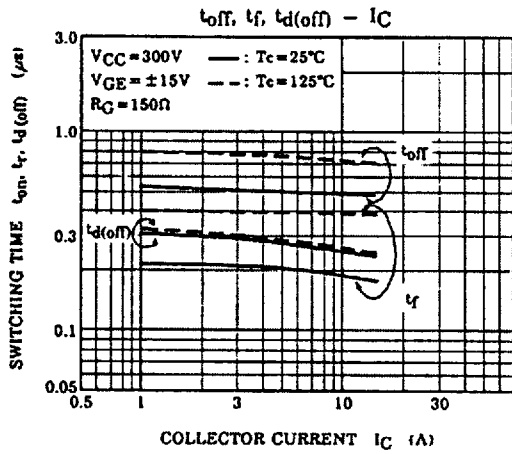
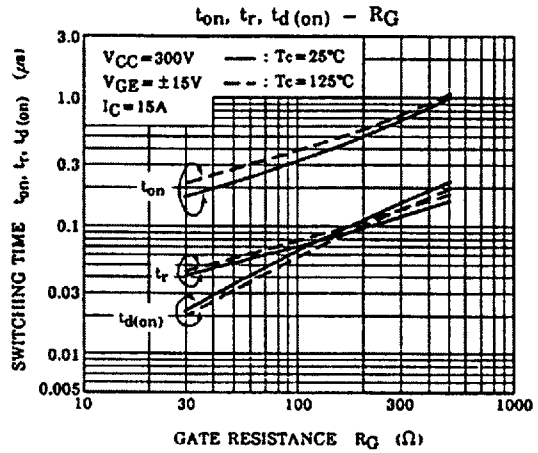
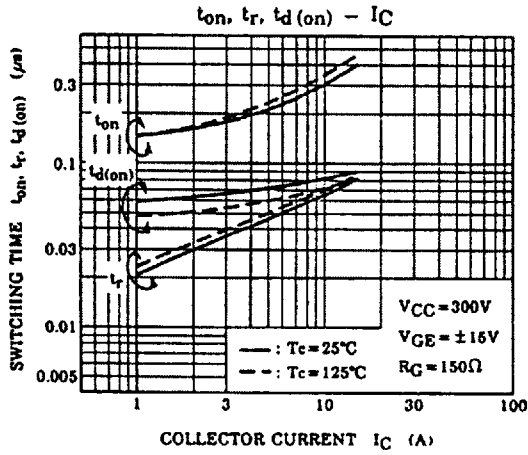

c. Brake Stage

