

FAIRCHILD
SEMICONDUCTOR®

P1086

P-Channel Switch

- This device is designed for low level analog switching sample and hold circuits and chopper stabilized amplifiers.
- Sourced from process 88.

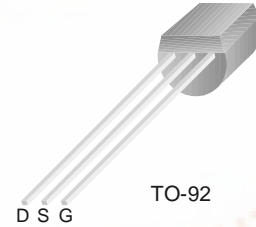

Absolute Maximum Ratings $T_C=25^\circ\text{C}$ unless otherwise noted

| Symbol | Parameter | Value | Units |
|----------------|--|------------|------------------|
| V_{DG} | Drain-Gate Voltage | - 30 | V |
| V_{GS} | Gate-Source Voltage | 30 | V |
| I_{GF} | Forward Gate Current | 50 | mA |
| T_J, T_{STG} | Operating and Storage Junction Temperature Range | -55 ~ +150 | $^\circ\text{C}$ |

* These ratings are limiting values above which the serviceability of any semiconductor device may be impaired.

NOTES:

1. These ratings are based on a maximum junction temperature of 150 degrees C.
2. These are steady state limits. The factory should be consulted on applications involving pulsed or low duty cycle operations.

Electrical Characteristics $T_C=25^\circ\text{C}$ unless otherwise noted

| Symbol | Parameter | Test Condition | Min. | Typ. | Max. | Units |
|---------------|---------------------------------|---|------|------|------|----------|
| BV_{GSS} | Gate-Source Breakdown Voltage | $V_{DS} = 0V, I_G = 1\mu A$ | 30 | | | V |
| I_{GSS} | Gate Reverse Current | $V_{GS} = 15V$ | | | 2 | nA |
| $I_{D(off)}$ | Drain Cutoff Leakage Current | $V_{DS} = 15V$ $V_{GS} = 12V$ $T = +85^\circ\text{C}$ | | | 10 | nA |
| I_{DGO} | Drain-Gate Leakage Current | $V_{DG} = 15V$ $I_S = 0$ $T = +85^\circ\text{C}$ | | | 0.5 | μA |
| I_{DSS} | Zero-Gate Voltage Drain Current | $V_{DS} = 20V, V_{GS} = 0V$ | 10 | | | mA |
| $V_{GS(off)}$ | Gate-Source Cutoff Voltage | $V_{DS} = 15V, I_D = 1\mu A$ | | | 10 | V |
| $V_{DS(on)}$ | Drain-Source On Voltage | $V_{GS} = 0V, I_D = 6mA$ | | | 0.5 | V |
| $r_{DS(on)}$ | Drain-Source On Resistance | $V_{GS} = 0V, I_D = 1mA$ | | | 75 | Ω |
| $r_{ds(on)}$ | Drain-Source On Resistance | $V_{GS} = 0V, I_D = 0, f = 1kHz$ | | | 75 | Ω |
| C_{iss} | Input Capacitance | $V_{DS} = 15V, V_{GS} = 0V, f = 1MHz$ | | | 45 | pF |
| C_{riss} | Reverse Transfer Capacitance | $V_{DS} = 0V, V_{GS} = 12V, f = 1MHz$ | | | 10 | pF |
| $t_d(on)$ | Trun On Time | $V_{DD} = -6V$ | | | 15 | ns |
| t_r | Rise Time | $V_{GS(off)} = +12V$ $R_L = 910\Omega$ | | | 20 | ns |
| $t_d(off)$ | Trun Off Time | $I_D(on) = 6mA$ | | | 15 | ns |
| t_f | Fall Time | | | | 50 | ns |

Thermal Characteristics $T_A=25^\circ\text{C}$ unless otherwise noted

| Symbol | Parameter | Max. | Units |
|-----------------|---|------------|----------------------------|
| P_D | Total Device Dissipation Derate above 25°C | 350 2.8 | mW mW/ $^\circ\text{C}$ |
| $R_{\theta JC}$ | Thermal Resistance, Junction to Case | 125 | $^\circ\text{C/W}$ |
| $R_{\theta JA}$ | Thermal Resistance, Junction to Ambient | 357 | $^\circ\text{C/W}$ |



Package Dimensions

P1086

TO-92

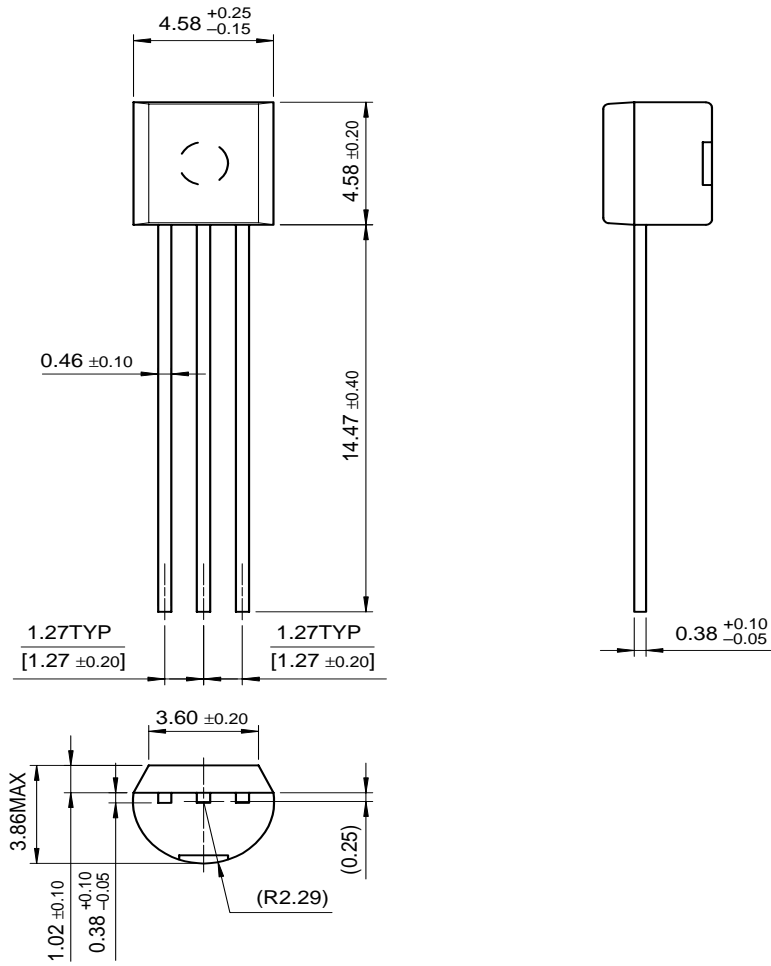

Dimensions in Millimeters

TRADEMARKS

The following are registered and unregistered trademarks Fairchild Semiconductor owns or is authorized to use and is not intended to be an exhaustive list of all such trademarks.

| | | | | |
|--------------------------------------|---------------------|--------------------|---------------------|-----------------|
| ACEx™ | FACT™ | ImpliedDisconnect™ | PACMAN™ | SPM™ |
| ActiveArray™ | FACT Quiet series™ | ISOPLANAR™ | POP™ | Stealth™ |
| Bottomless™ | FAST® | LittleFET™ | Power247™ | SuperSOT™-3 |
| CoolFET™ | FASTr™ | MicroFET™ | PowerTrench® | SuperSOT™-6 |
| CROSSVOLT™ | FRFET™ | MicroPak™ | QFET™ | SuperSOT™-8 |
| DOMET™ | GlobalOptoisolator™ | MICROWIRE™ | QS™ | SyncFET™ |
| EcoSPARK™ | GTO™ | MSX™ | QT Optoelectronics™ | TinyLogic™ |
| E ² CMOS™ | HiSeC™ | MSXPro™ | Quiet Series™ | TruTranslation™ |
| EnSigna™ | I ² C™ | OCX™ | RapidConfigure™ | UHC™ |
| Across the board. Around the world.™ | | OCXPro™ | RapidConnect™ | UltraFET® |
| The Power Franchise™ | | OPTOLOGIC® | SILENT SWITCHER® | VCX™ |
| Programmable Active Droop™ | | OPTOPLANAR™ | SMART START™ | |

DISCLAIMER

FAIRCHILD SEMICONDUCTOR RESERVES THE RIGHT TO MAKE CHANGES WITHOUT FURTHER NOTICE TO ANY PRODUCTS HEREIN TO IMPROVE RELIABILITY, FUNCTION OR DESIGN. FAIRCHILD DOES NOT ASSUME ANY LIABILITY ARISING OUT OF THE APPLICATION OR USE OF ANY PRODUCT OR CIRCUIT DESCRIBED HEREIN; NEITHER DOES IT CONVEY ANY LICENSE UNDER ITS PATENT RIGHTS, NOR THE RIGHTS OF OTHERS.

LIFE SUPPORT POLICY

FAIRCHILD'S PRODUCTS ARE NOT AUTHORIZED FOR USE AS CRITICAL COMPONENTS IN LIFE SUPPORT DEVICES OR SYSTEMS WITHOUT THE EXPRESS WRITTEN APPROVAL OF FAIRCHILD SEMICONDUCTOR CORPORATION.

As used herein:

1. Life support devices or systems are devices or systems which, (a) are intended for surgical implant into the body, or (b) support or sustain life, or (c) whose failure to perform when properly used in accordance with instructions for use provided in the labeling, can be reasonably expected to result in significant injury to the user.
2. A critical component is any component of a life support device or system whose failure to perform can be reasonably expected to cause the failure of the life support device or system, or to affect its safety or effectiveness.

PRODUCT STATUS DEFINITIONS

Definition of Terms

| Datasheet Identification | Product Status | Definition |
|--------------------------|------------------------|---|
| Advance Information | Formative or In Design | This datasheet contains the design specifications for product development. Specifications may change in any manner without notice. |
| Preliminary | First Production | This datasheet contains preliminary data, and supplementary data will be published at a later date. Fairchild Semiconductor reserves the right to make changes at any time without notice in order to improve design. |
| No Identification Needed | Full Production | This datasheet contains final specifications. Fairchild Semiconductor reserves the right to make changes at any time without notice in order to improve design. |
| Obsolete | Not In Production | This datasheet contains specifications on a product that has been discontinued by Fairchild semiconductor. The datasheet is printed for reference information only. |