



Vector Modulator, 1.94 to 2.24 GHz

V 4.00

SA90-0001

Features

- Operates 1.94 to 2.24 GHz
- Chip Scale Package.
- Low Amplitude Ripple
- Linear Phase
- 50 Ohm nominal impedance
- Continuously Variable Across a Full 360 degree range
- Test Boards to be Available

Description

M/A-COM's SA90-0001 is a Vector Modulator that significantly reduces the required board space compared to hybrid solutions. The monolithic passive elements will lead to greater repeatability lot-to-lot. Low amplitude ripple will provide superior performance. High intercept and compression points will contribute to more linear system performance. SA90-0001 is ideally suited for wireless infrastructure applications.

M/A-COM's MADRCC0002 Dual Linearizer is designed to simplify the control of Vector Modulators. See Figure 1 and App Note AN3001.

CSP-6

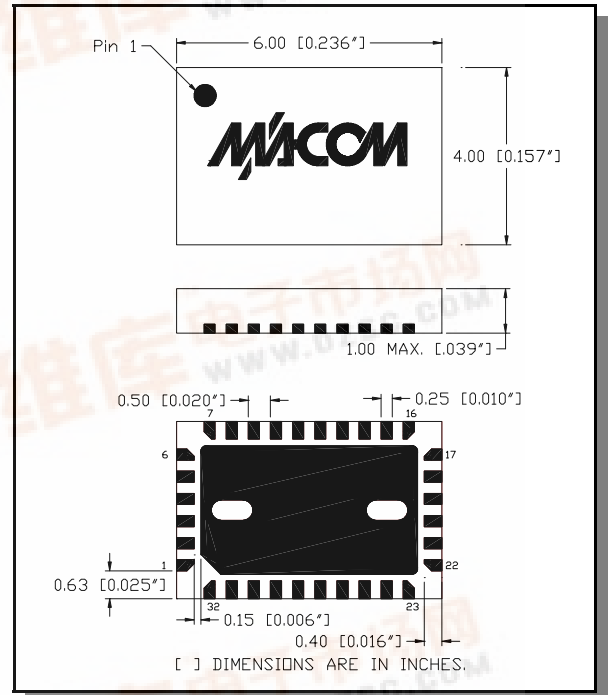

Electrical Specifications $T_A = +25^\circ$

Parameter	Test Conditions	Frequency	Units	Min	Typical	Max
Impedance	—	—	O	—	50	—
Reference Loss	Z = 50O	1.94—2.34 GHz	dB	-13.5	—	-10.0
Attenuation Range	Z = 50O Above Reference Loss	1.94—2.34 GHz	dB	10	—	—
Phase Shift Range	Z = 50O, Over minimum Attenuation Range	1.94—2.34 GHz	deg	0	—	360
Amplitude Ripple	Z = 50O, Ref Loss	2.08—2.20 GHz	dB	—	—	±0.2
	Z = 50O, 5 dB above Ref Loss	2.08—2.20 GHz	dB	—	—	±0.25
	Z = 50O, 10 dB above Ref Loss	2.08—2.20 GHz	dB	—	—	±0.3
	Z = 50O, Ref Loss	2.04—2.24 GHz	dB	—	—	±0.35
	Z = 50O, 5 dB above Ref Loss	2.04—2.24 GHz	dB	—	—	±0.4
	Z = 50O, 10 dB above Ref Loss	2.04—2.24 GHz	dB	—	—	±0.5
Deviation from Linear Phase	Z = 50O, Ref Loss	2.08—2.20 GHz	deg	—	—	±0.5
	Z = 50O, 5 dB above Ref Loss	2.08—2.20 GHz	deg	—	—	±1.0
	Z = 50O, 10 dB above Ref Loss	2.08—2.20 GHz	deg	—	—	±1.5
	Z = 50O, Ref Loss	2.04—2.24 GHz	deg	—	—	±1.0
	Z = 50O, 5 dB above Ref Loss	2.04—2.24 GHz	deg	—	—	±1.5
	Z = 50O, 10 dB above Ref Loss	2.04—2.24 GHz	deg	—	—	±2.0
Return Loss	Over 10 dB Attenuation Range	2.04—2.24 GHz	dB	15	—	—
Input IP_3	Over 10 dB Attenuation Range	2.04—2.24 GHz	dBm	—	+41	—
Input P_{1dB}	Over 10 dB Attenuation Range	2.04—2.24 GHz	dBm	—	+29	—
Noise Figure	Over 10 dB Attenuation Range	2.04—2.24 GHz	dB	—	—	Note 1
Switching Speed	50% Control to 10%/90% RF	—	ns	—	500	—
I Supply	—	—	mA	—	—	100



Absolute Maximum Ratings ²

Parameter	Absolute Maximum
Max. Input Power 1.5 to 2.0 GHz Other Frequencies	+34 dBm +24 dBm
DC Voltages ³ Vbias1 or Vbias2	+1.0V
DC Current	50 mA Max per Bias
Operating Temperature	-40°C to +85°C
Storage Temperature	-65°C to +125°C

2. Operation of this device above any one of these parameters may cause permanent damage.
3. Note that external dropping resistors are required to limit the current and voltage on the PIN diodes.

Schematic

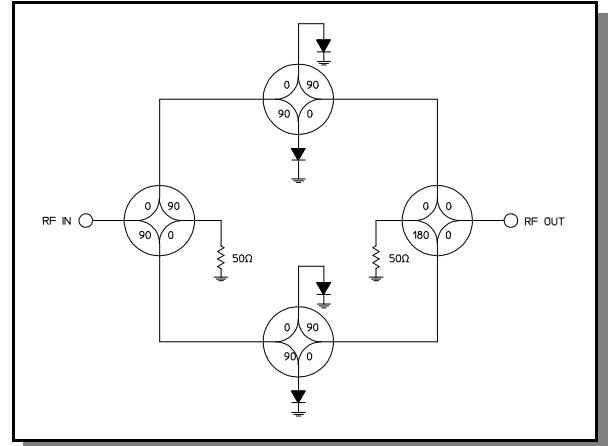

Pad Configuration

Pin #	Function	Pin #	Function
1	NC	17	NC
2	NC	18	NC
3	NC	19	NC
4	NC	20	NC
5	NC	21	NC
6	NC	22	NC
7	NC	23	NC
8	NC	24	Bias 2B
9	Bias 1A	25	NC
10	NC	26	GND
11	GND	27	RF OUT
12	RF IN	28	GND
13	GND	29	NC
14	NC	30	Bias 1B
15	Bias 2A	31	NC
16	NC	32	NC

Recommended PCB Layout

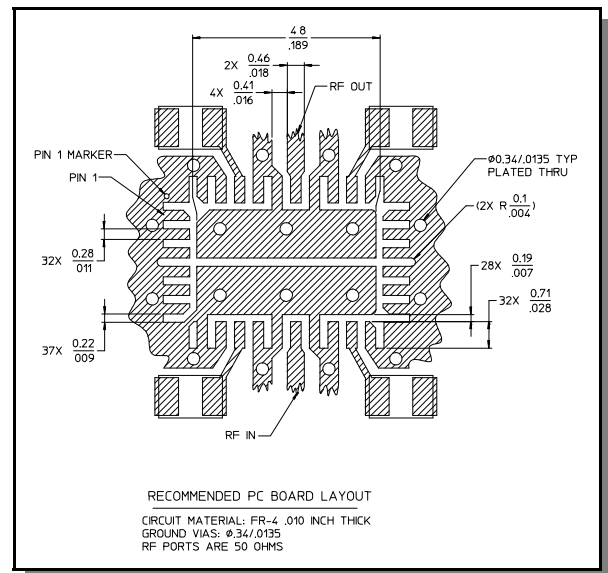

Specifications subject to change without notice.

- North America: Tel. (800) 366-2266
- Asia/Pacific: Tel.+81-44-844-8296, Fax +81-44-844-8298
- Europe: Tel. +44 (1344) 869 595, Fax+44 (1344) 300 020

Figure 1A - Phase and Attenuation of SA90-0001, Vector Modulator Linearized with MADRCC0002 Dual Linearizer

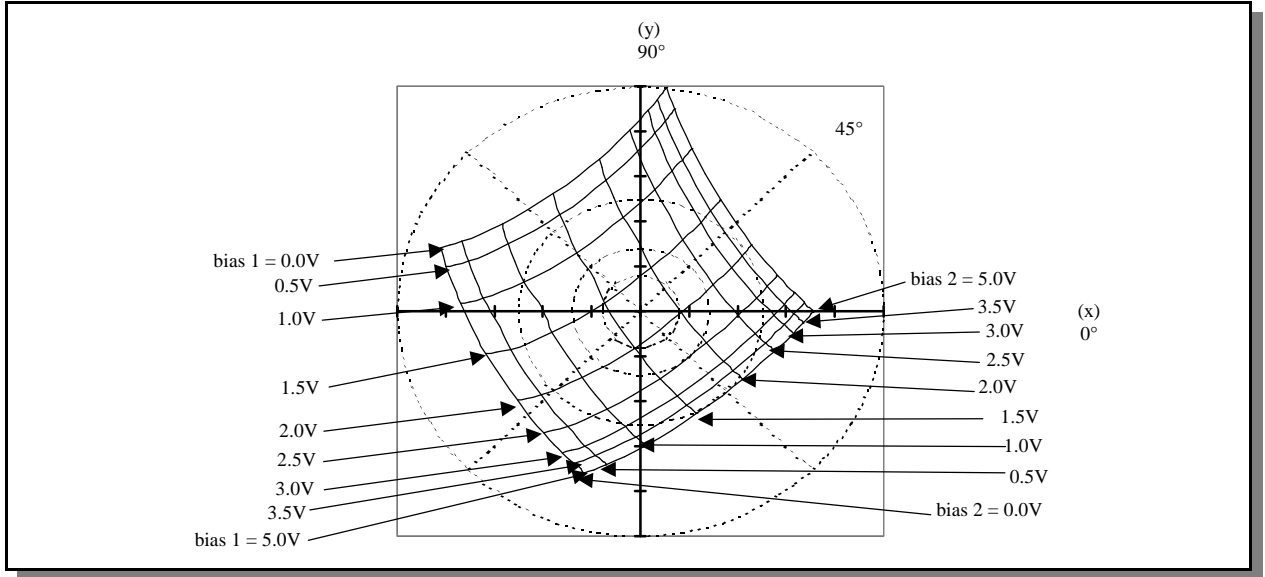
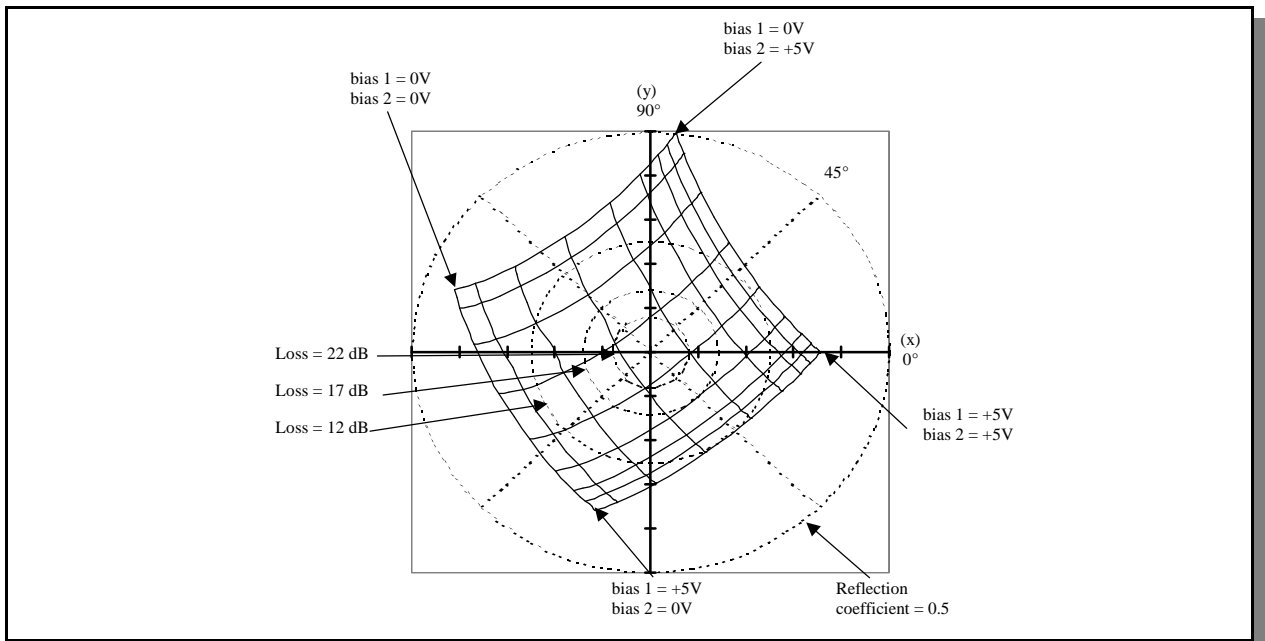

Figure 1B



4. Tic marks on x,y axes refer to reflection coefficient in increments of 0.1V. Reflection coefficients vary from -0.5 to +0.5 on both the x and y axes.
5. Data is for vector modulators driven by linearizers per attached schematic.
6. Inputs to the linearizers vary from 0 to 5V.
7. The phase with the inputs to both linearizers set to +5V is arbitrarily called zero degrees.

Specifications subject to change without notice.

Figure 2A - Phase and Attenuation of SA90-0001 vs. Bias Current

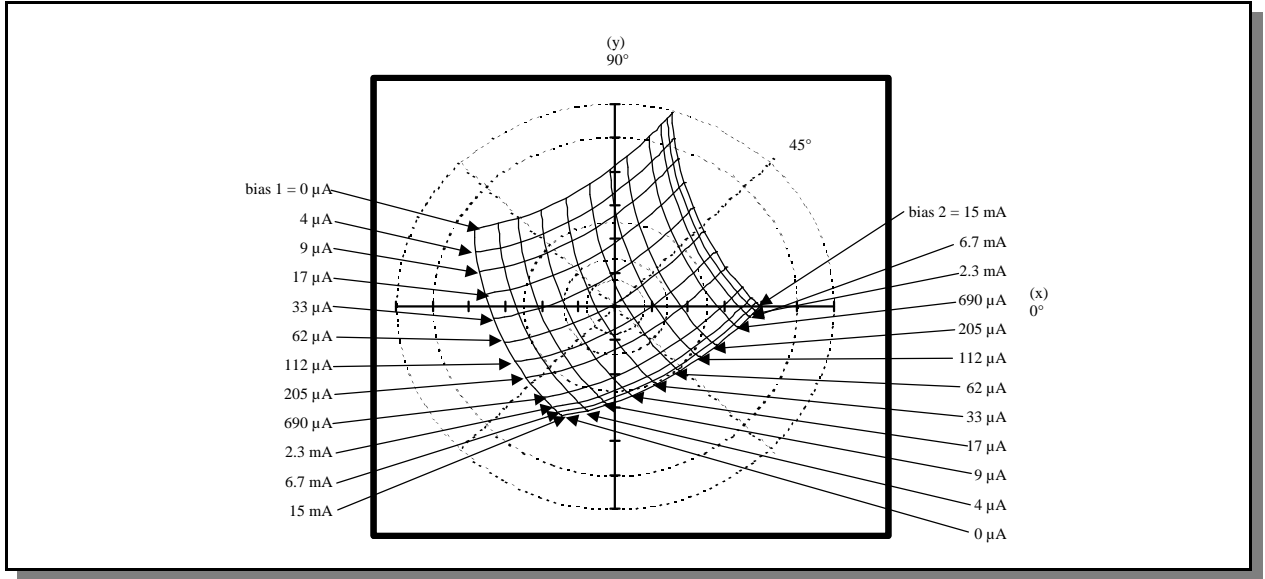
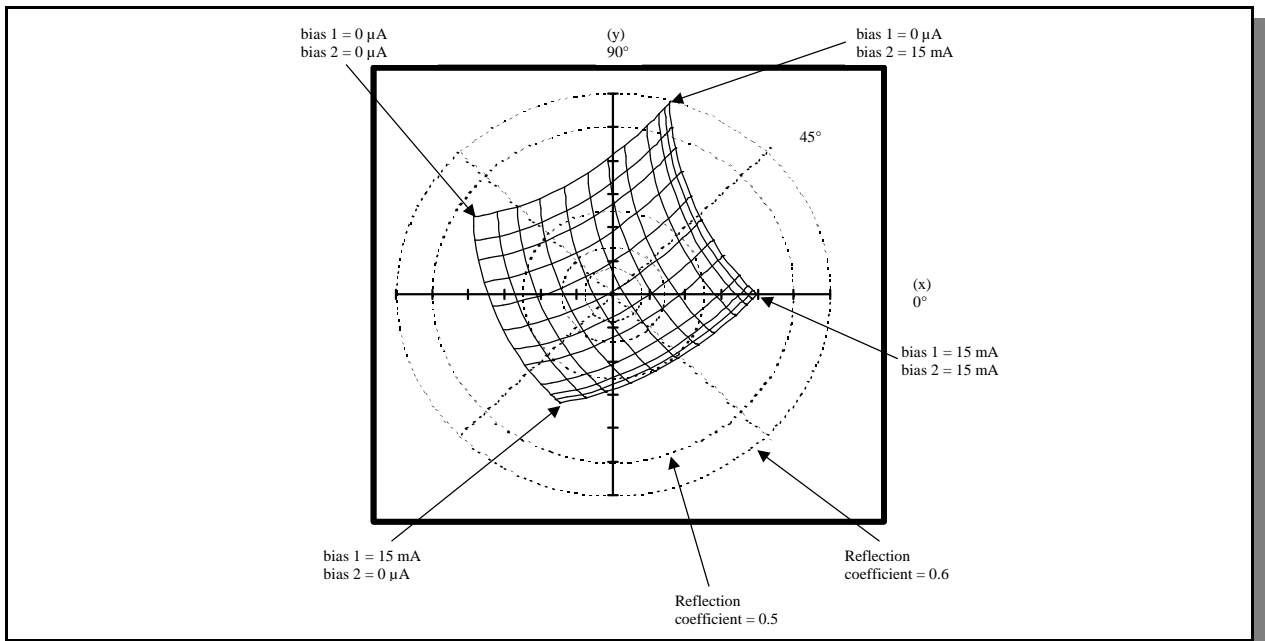

Figure 2B



8. Tic marks on x,y axes refer to reflection coefficient in increments of 0.1. Reflection coefficients vary from -0.6 to +0.6 on both the x and y axes.
9. The phase with the inputs to both linearizers set to +15mA is arbitrarily called zero degrees.

Specifications subject to change without notice.

- North America: Tel. (800) 366-2266
- Asia/Pacific: Tel.+81-44-844-8296, Fax +81-44-844-8298
- Europe: Tel. +44 (1344) 869 595, Fax+44 (1344) 300 020

Ordering Information

Part Number	Package
SA90-0001	Bulk Packaging
SA90-0001TR	Tape and Reel
SA90-0001-DC000	Units Mounted on Test Board with Driver

Functional Block Diagram

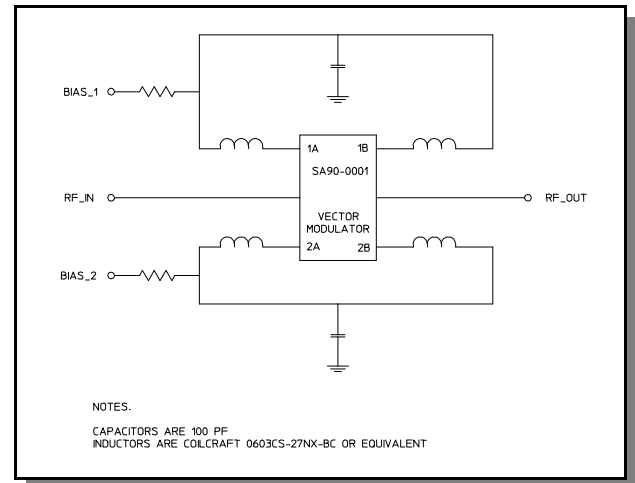

Specifications subject to change without notice.

- North America: Tel. (800) 366-2266
- Asia/Pacific: Tel.+81-44-844-8296, Fax +81-44-844-8298
- Europe: Tel. +44 (1344) 869 595, Fax+44 (1344) 300 020