

High-Speed Analog N-Channel/Enhancement-Mode DMOS FETS



SD400 / SD402

FEATURES

- Fast switching $t_{on} < 1ns$
- Low capacitance $C_{rss} 0.3 pF (typ)$
- Low threshold $< 1.5V max$
- CMOS and TTL Compatible Input

APPLICATIONS

- Switch Drivers
- Video Switches
- Active Pullups
- VHF/UHF Amplifiers

DESCRIPTION

The SD400 and SD402 are N-Channel Enhancement Mode devices processed utilizing Calogic's proprietary high speed, low capacitance lateral DMOS technology. These devices are excellent switch drivers where low threshold offers the designer the advantage of CMOS and TTL compatibility with ultra high switching speeds.

ORDERING INFORMATION

Part	Package	Temperature Range
SD400BD	Plastic TO-92	-55°C to +125°C
SD402BD	Plastic TO-92	-55°C to +125°C
XSD400	Sorted Chips in Carriers	-55°C to +125°C
XSD402	Sorted Chips in Carriers	-55°C to +125°C

PIN CONFIGURATION



CD1-1

SCHEMATIC DIAGRAM

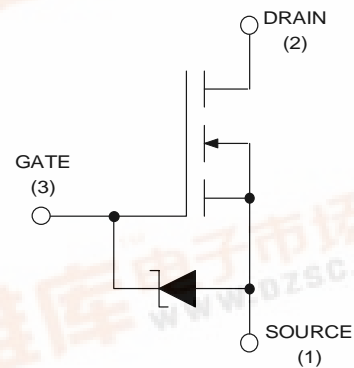



ABSOLUTE MAXIMUM RATINGS (T_C = +25°C unless otherwise noted)

V _{DS}	Drain-Source Voltage		V _{SD}	Source-Drain Voltage	-0.3 V
	SD400	+30V	I _D	Continuous Drain Current	50 mA
	SD402	+15V		Power Dissipation (at or below T _C = +25°C)	300mW
V _{GS}	Gate-Source Voltage	-0.3 V		Linear Derating Factor	3.0 mW/°C
		+20 V		Operating Storage and	
V _{DG}	Gate-Drain Voltage	-0.3 V		Junction Temperature Range	-55°C to +125°C
		+20 V			

ELECTRICAL CHARACTERISTICS (T_A = +25°C unless otherwise noted)

SYMBOL	CHARACTERISTICS	SD400			SD402			UNIT	TEST CONDITIONS
		MIN	TYP	MAX	MIN	TYP	MAX		
STATIC									
BV _{DSS}	Drain-Source Breakdown Voltage	30	35		15	25		V	I _D = 1.0μA, V _{GS} = 0
I _{D(OFF)}	Drain-Source OFF Leakage Current			1.0			1.0	μA	V _{DS} = 15 V, V _{GS} = 0
I _{GSS}	Gate-Source Leakage Current			1.0			1.0	μA	V _{GS} = 20 V, V _{DS} = 0
I _{D(ON)}	Drain-Source ON Current	50	100		50	100		mA	V _{DS} = 10 V, V _{GS} = 10 V Pulse Test
V _{GS(th)}	Gate-Source Threshold Voltage	0.7		1.5	0.7		1.5	V	I _D = 1.0 μA, V _{DS} = V _{GS}
V _{DS(ON)}	Drain-Source ON Voltage		150	250		150	250	mV	I _D = 1 mA, V _{GS} = 2.4 V
r _{DS(ON)}	Drain-Source ON Resistance		150	250		150	250	ohms	
V _{DS(ON)}	Drain-Source ON Voltage		60	80		60	80	mV	I _D = 1 mA, V _{GS} = 4.5 V
r _{DS(ON)}	Drain-Source ON Resistance		60	80		60	80	ohms	
DYNAMIC									
g _{fs}	Common-Source Forward Transconductance	8.0	12		8.0	12		mS	I _D = 20 mA, V _{DS} = 10 V f = 1 KHz Pulse Test
C _{iss}	Common-Source Input Capacitance		4.0	5.0		4.0	5.0	pF	V _{DS} = 10 V, V _{GS} = 0 f = 1 MHz
C _{oss}	Common-Source Output Capacitance		1.8	2.5		1.8	2.5		
C _{rss}	Common-Source Reverse Transfer Capacitance		0.3	0.5		0.3	0.5		
t _{d(ON)}	Turn ON Delay Time		0.7	1.0		0.7	1.0	ns	V _{DD} = 10 V, R _L = 680 V _{G(ON)} = 10 V, R _G = 51 C _L = 1.5 pF
t _r	Rise Time		0.8	1.0		0.8	1.0		
t _(OFF)	Turn OFF Time		12			12			