

# 三合微科股份有限公司

SAMHOP Microelectronics Corp.

# SM7153

## ELECTRONIC VOLUME CONTROLLER

### FEATURES

- \* 0dB to -66dB attenuation controlled by 2dB/step
- \* 2 channels built in
- \* High voltage CMOS technology operating voltage range: VCC=6 ~ 12V

### APPLICATION

Audio Equipment Volume Control.

### PIN ASSIGNMENT

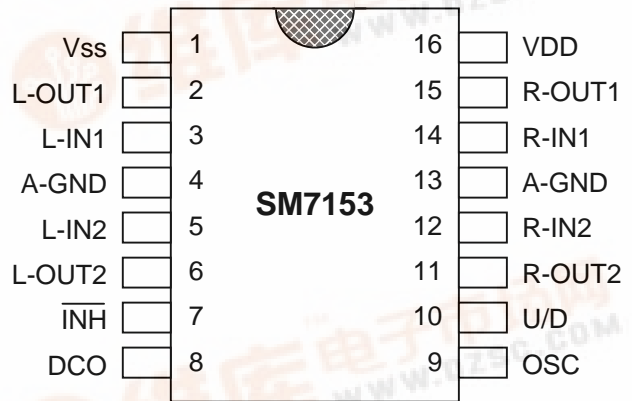

### BLOCK DIAGRAM

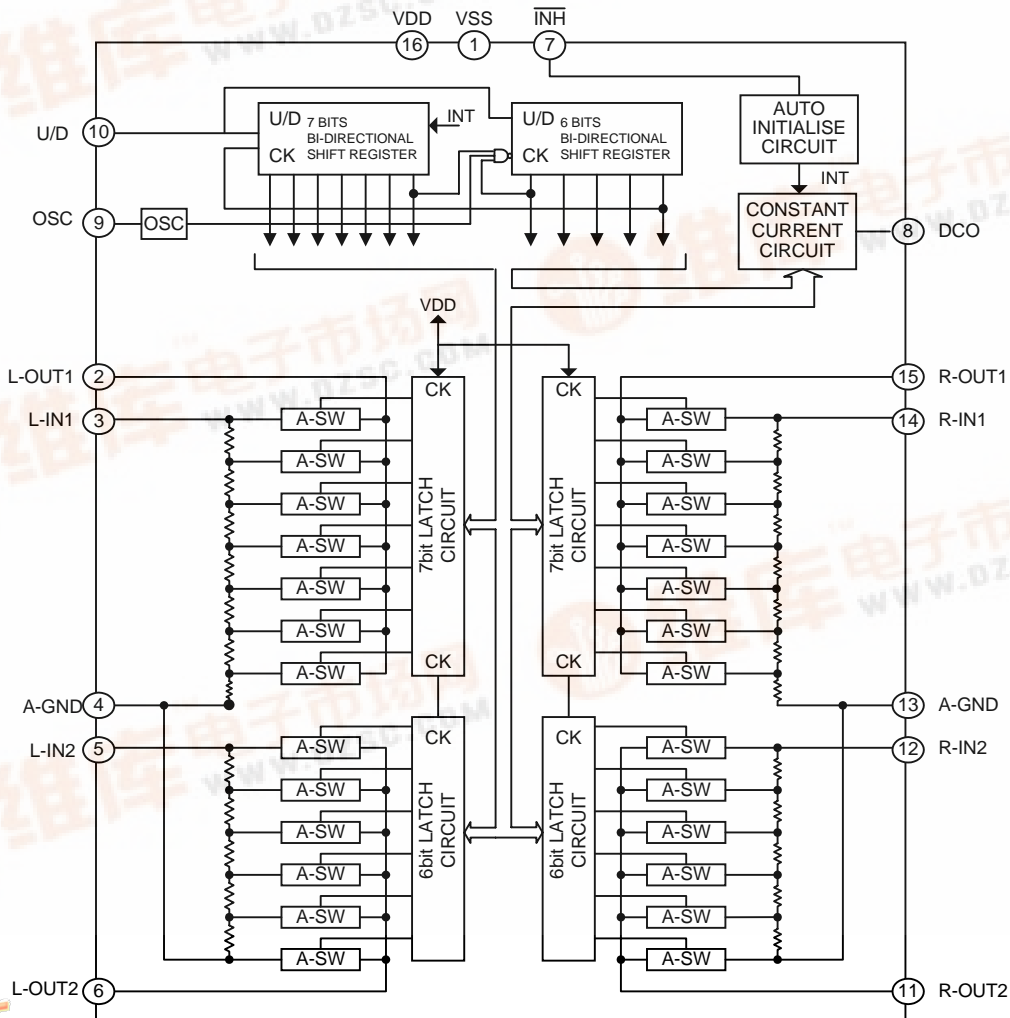



**PIN DESCRIPTION**

Pin	Symbol	Description
2	L-OUT1	10dB/step attenuator outputs.
15	R-OUT1	A signal applied to IN is attenuated in 7 steps from 0dB to 60dB at 10dB/step.
3 14	L-IN1 R-IN1	10dB/step attenuator inputs
4 13	A-GND	Analog ground terminal
5 12	L-IN2 R-IN2	2 dB/step attenuator inputs
6	L-OUT2	2 dB/step attenuator inputs
11	R-OUT2	A signal applied to IN is attenuated in 5 steps from 0dB to 8dB at 2 dB/step.
7	$\overline{\text{INH}}$	Inhibit terminal. When this terminal is at ' L ' level, all input/output cut off and the SM7153 is placed in the inhibit state. When at ' H ' level, the SM7153 operates normally.
8	DCO	DC current output for displaying attenuation.
9	OSC	C, R connecting terminal for the oscillator. up/down speed of attenuation is decided by the attenuation up/down control oscillator according to this time constant.
10	U/D	Attenuation up/down control input terminal. When this terminal is at ' H ' level, sound volume is increased synchronising with rise of the oscillator. Conversely, when this pin is at ' L ' level, sound volume is decreased.
1	VSS	Negative Power Supply
16	VDD	Positive Power Supply (Substrate)

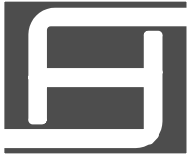

FUNCTION DESCRIPTION

(1) Setting Of Attenuation

After power on, attenuation is automatically set at -40dB.

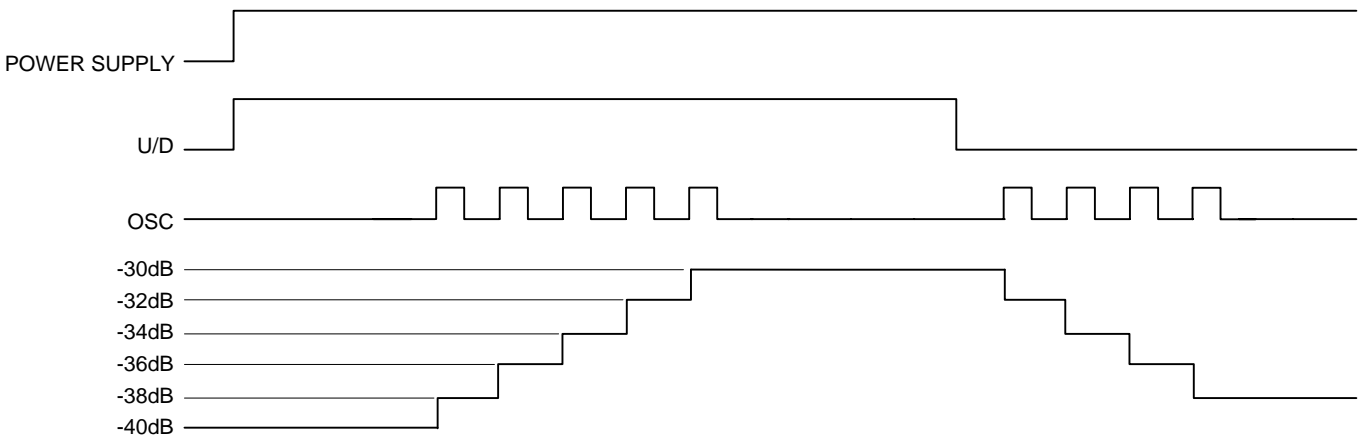

Figure 1

When the UP key is pressed after power ON, the U/D terminal is placed in the up state at ' H ' level, and the oscillator is actuated.

When the DOWN key is pressed, the U/D terminal is placed in the down state and therefore, attenuation is decreased. Oscillation frequency is decided by Cx and Rx.

fosc = 1 / (0.7 \* Cx \* Rx) (Hz) (Rs = 3Rx)

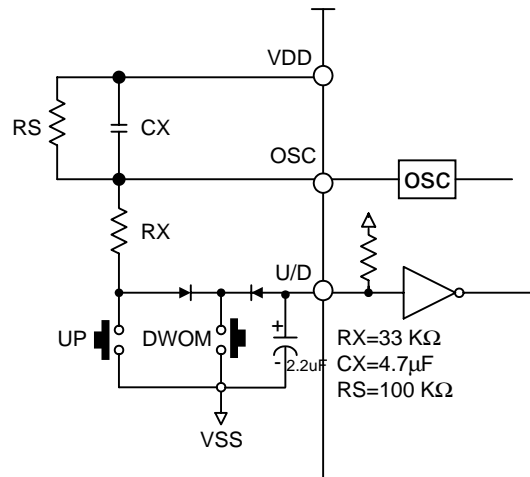
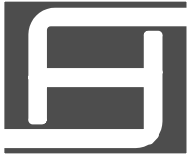

Figure 2



(2) Attenuation Display Output

The SM7153 is provided with the DC current output terminal for displaying attenuation. With 0dB ~ divided into 13 steps, current of approx. 100µA/step is transmitted.

Step	DCO	Attenuation
0	0	-64 dB ~
1	$I = 100 \mu A + 30 \mu A$	-60dB ~ -62dB
2	$2 \times I$	-54dB ~ -58dB
3	$3 \times I$	-50dB ~ -52dB
4	$4 \times I$	-44dB ~ -48dB
5	$5 \times I$	-40dB ~ -42dB
6	$6 \times I$	-34dB ~ -38dB
7	$7 \times I$	-30dB ~ -32dB
8	$8 \times I$	-24dB ~ -28dB
9	$9 \times I$	-20dB ~ -22dB
10	$10 \times I$	-14dB ~ -18dB
11	$11 \times I$	-10dB ~ -12dB
12	$12 \times I$	-4dB ~ -8dB
13	$13 \times I$	0dB ~ -2dB

TABLE 1

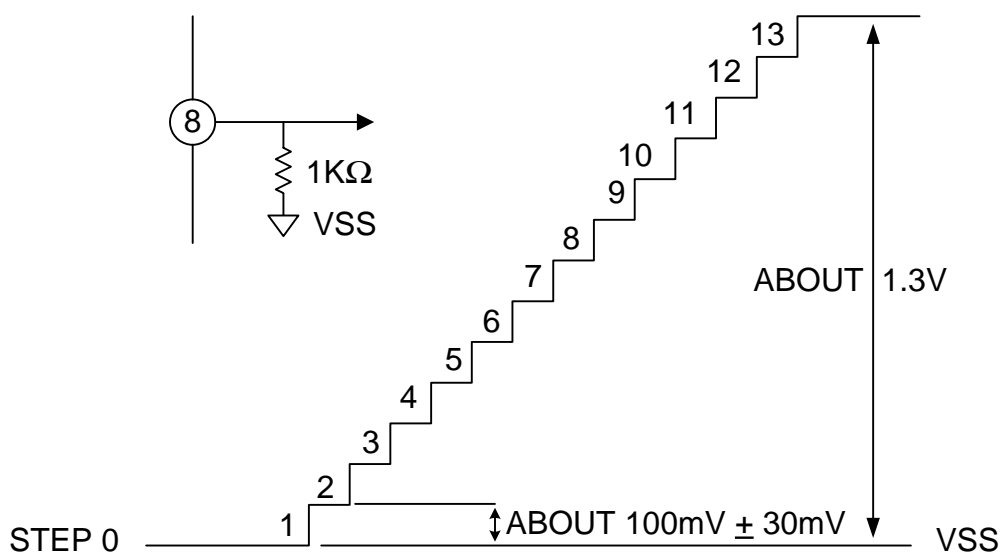
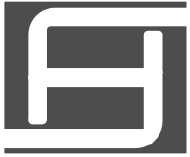

Figure 3

When high precision is required, use a variable resistor as a load resistor.



### (3) Attenuator

The attenuator unit consist of diffused resistors and analog switches. Attenuator 1 attenuates 0~60dB at 10dB/step while Attenuator 2 attenuates 2~8dB at 2dB/step, a total of 0~66dB at 2dB/step.

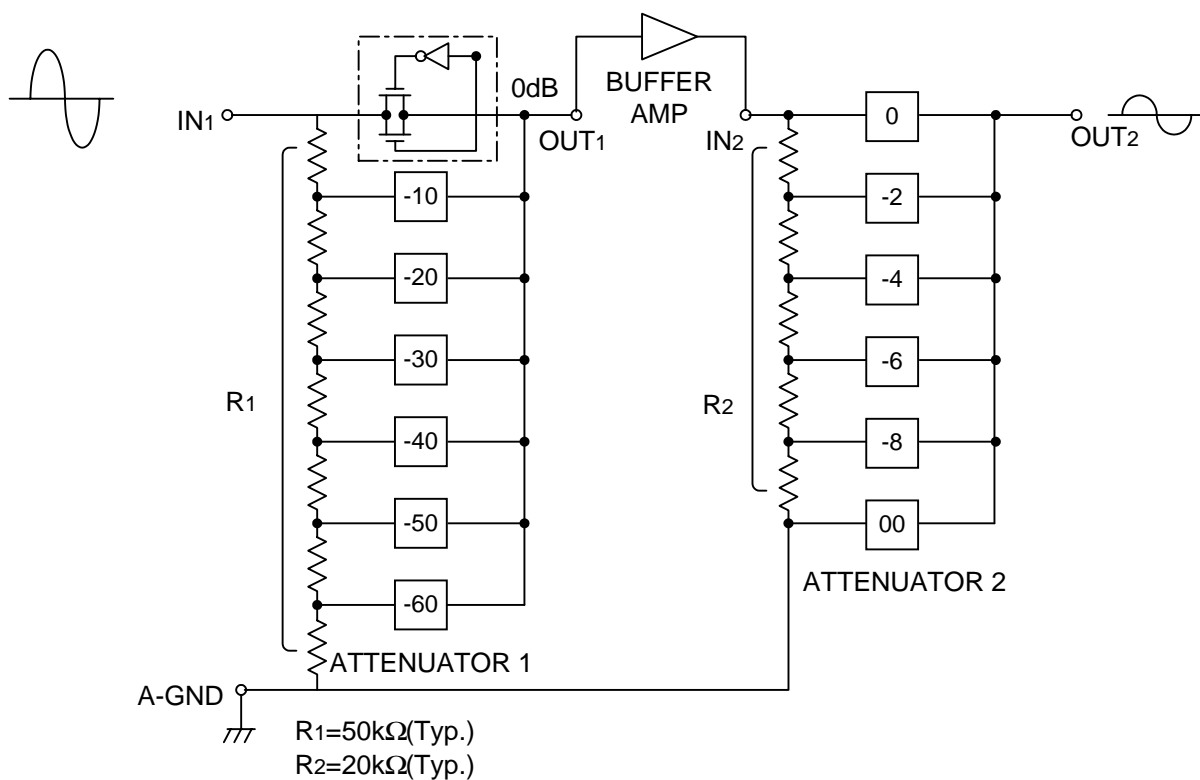

Figure 4

If there is the possibility for excessive voltage being to the attenuator, it is recommended to insert a protective diode as illustrated below.

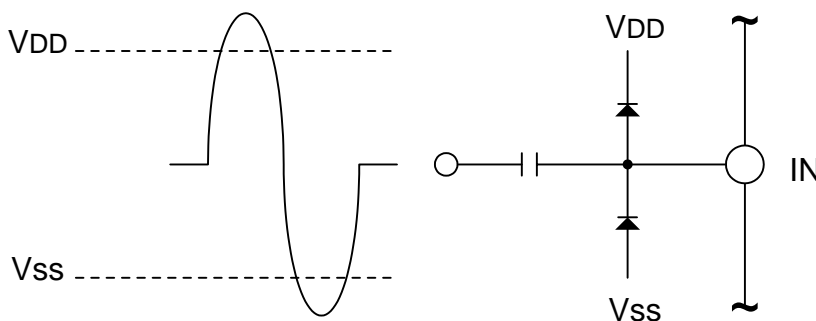

Figure 5



(4) Power Supply

(a) Dual Power Supply

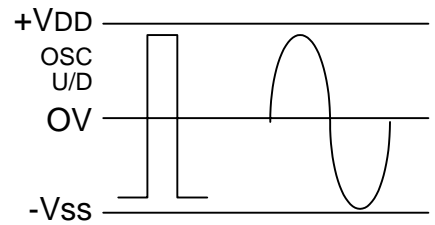
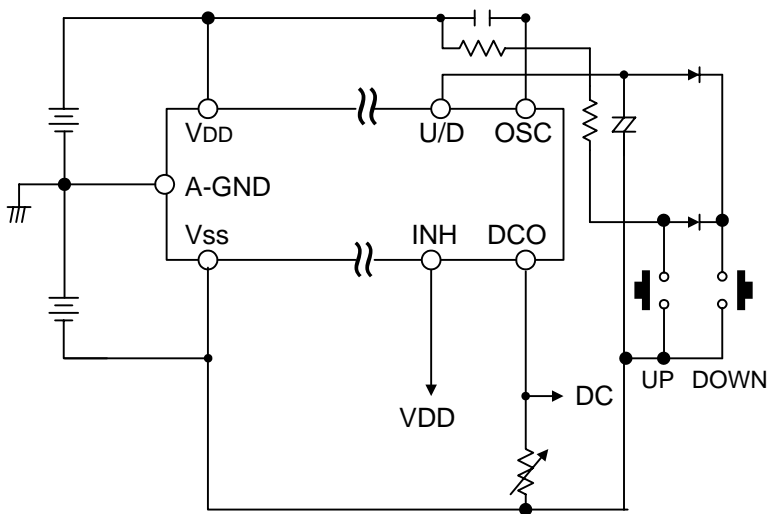

Figure 6

(b) Single Power Supply

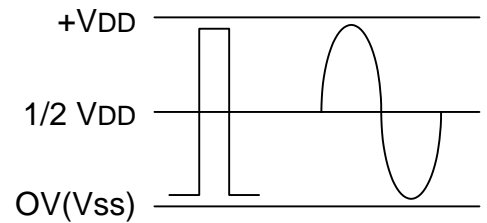
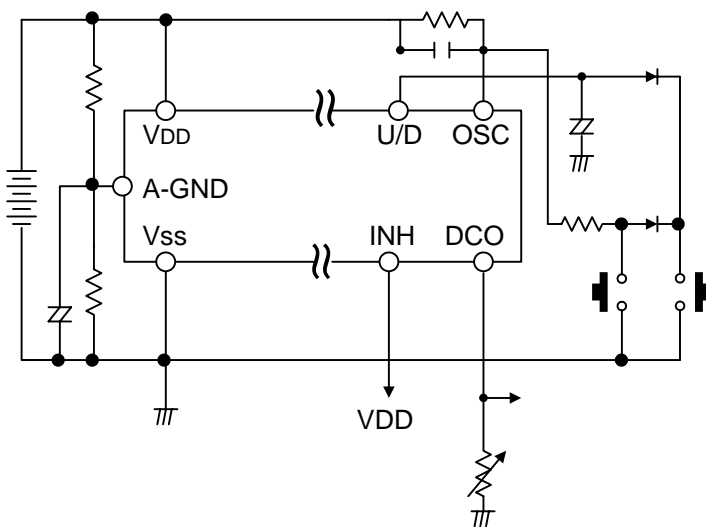

Figure 7



### (5) Backup When Power Off

When the INH terminal is set at ' L ' level, all input/output terminals are shut off and current consumption is reduced to the minimum. The back up by means of a capacitor becomes possible in this condition. An application circuit is shown in Figure 8.

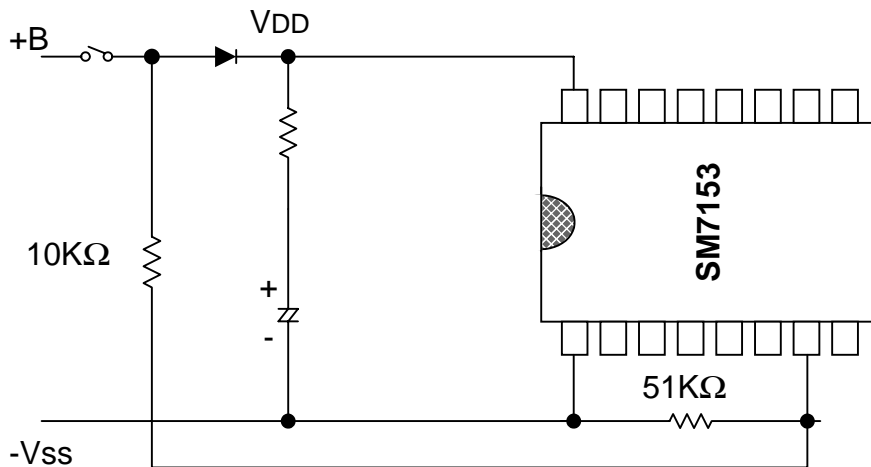

Figure 8

If  $VDD - V_{ss}$  drops below 4V, the backup becomes impossible.

### (6) Initialisation When Power ON

When  $VDD - V_{SS}$  drops below 4V, the auto-initialising function is actuated. The initialising level is -40dB. If rise of power supply is to It is recommended to rise supply voltage and the INH terminal as illustrated below.

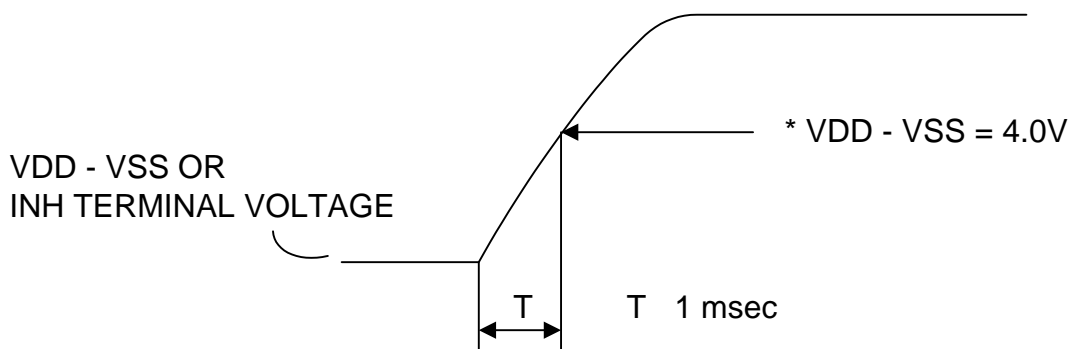

Figure 9



**MAXIMUM RATINGS (TA=25°C)**

Parameter	Symbol	Ratings	Unit
Supply Voltage	VDD	15	V
Input Voltage	VIN	VSS-0.3 ~ VDD+0.3	V
Power Dissipation	PD	150	mW
Operating Temperature	Topr	-20 ~ +75	
Storage Temperature	Tstg	-40 ~ +125	

**ELECTRICAL CHARACTERISTICS**

(Unless otherwise specified, VDD=12V, VSS=0V, Ta=25°C)

Parameter	Symbol	Test Condition	Min.	Typ.	Max.	Unit
Supply Voltage	VDD		6	-	12	V
Supply Current	IDD		-	1	3	mA
Stand-by Current	IB	VDD=4V, INH=L	-	-	300	μA
Input Voltage	'H' LEVEL	VIH INH, U/D Terminal	0.8VDD	-	VDD+0.3	V
	'L' LEVEL					
Attenuator 1 resistor (10dB / step)	RATT-1	R-IN1 -A-GND (L-IN1)	25	50	70	KΩ
Attenuator 2 resistor (2dB / step)	RATT-2	R-IN2 -A-GND (L-IN2)	10	20	28	KΩ
Attenuation Error	-		-	-	2	dB
Max input Amplitude	Vin	Biase 0V	-	-	4.0	Vrms
Max clock Frequency	fck		-	-	100	KHz
Min clock Width	Tck		5	-	-	μS

