



6+2-CH. MULTISTANDARD AUDIO DECODER

PRELIMINARY DATA

1 FEATURES

■ DVD Audio decoder:

- **Meridian Lossless Packing (MLP)**, with up to 6 channels,
- Uncompressed LPCM with 1-8 channels,
- Precision of up to 24 bits and sample rates of between 44.1 kHz and 192 kHz.

■ Dolby Digital (*) decoder:

- Decodes 5.1 *Dolby Digital Surround*.
- Output up to 6 channels. downmix modes: 1, 2, 3 or 4 channels.

■ MPEG -1 2- channel audio decoder, layers I and II.

■ MPEG-2 6-channel audio decoder, layer II.

- 24 bits decoding precision.

■ MP3 (MPEG layer III) decoder.

- Accepts MPEG-2 PES stream format for: MPEG-2, MPEG-1, Dolby Digital and linear PCM.

■ Karaoke System.

■ Prologic decoder.

■ Downmix for Dolby Prologic compatible.

- A separate (2-ch) PCM output available for simultaneous playing and recording.

■ Bitstream input interface: serial, parallel or SPDIF.

■ SPDIF and IEC-61937 input interface.

■ SPDIF and IEC-61937 output interface.

■ PLL for internal PCM clock generation. frequencies supported: 44.1KHz family (22.05, 88.2, 176.4) and 48KHz family (24, 48, 96, 192).

■ PCM: transparent, downsampling 192 to 96 KHz and 96 to 48kHz.

■ PTS handling control on-chip.

■ No external DRAM required

■ I²C or parallel control bus

■ Embedded *Development RAM* for customizable software capability.

■ Configurable internal PLLs for system and audio clocks, from an externally provided clock.

■ 80-PIN TQFP package

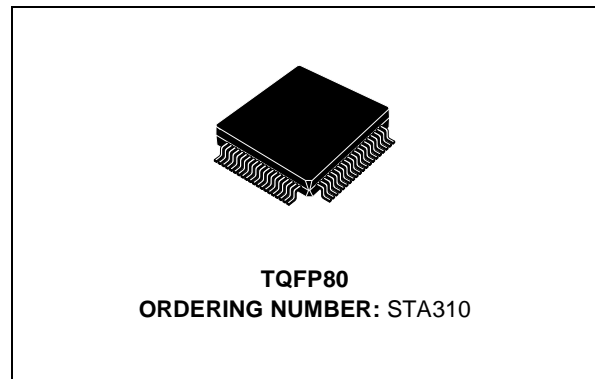

- 2.5V (for core) and 3V (for I/O) power supply.
 - 3V Capable I/O Pads .
- True-SPDIF input receiver supporting AES/EBU, IEC958, S/PDIF.
 - No external chip required.
 - Differential or single ended inputs can be decoded.

APPLICATIONS

- High-end audio equipment.
- DVD consumer players.
- Set top box.
- HDTV .
- Multimedia PC.

(*) “Dolby “, “AC-3” and “ProLogic” are trademarks of **Dolby Laboratories**.

DESCRIPTION

The STA310 is a fully integrated Audio Decoder capable of decoding all the above listed formats.

Encoded input data can be entered either by a serial (I2S or SPDIF) or a parallel interface. A second input data stream (I2S) is available for micro input.

The control interface can be either I²C or a parallel 8-bit interface. No external DRAM is necessary for a total of 35ms surround delays.

STA310

2 STA310 AUDIO DECODER PIN DESCRIPTION

Pin Number	Name	Type	Function
CONTROL INTERFACES			
48	IRQB	O ⁽¹⁾	Interrupt Signal (level), active low
47	SELI2C	I ⁽²⁾	Selects the Control Interface (when high: serial interface; when low: parallel interface)
I²C Control Interface			
43	SDAI2C	I/O ⁽¹⁾	I ² C Serial Data
46	SCLKI2C	I	I ² C Clock
53	MAINI2CADR	I ⁽²⁾	Determines the slave address
Parallel Control Interface			
78 - 79 - 80 - 1 2 - 3 - 6 - 7	D0 - D1 - D2 - D3 D4 - D5 - D6 - D7	I/O	Host Data
12 - 13 - 14 - 15 16 - 18 - 19 - 20	A0 - A1 - A2 - A3 A4 - A5 - A6 - A7	I	Host Address
21	DCSB	I	Chip Select, active low
22	R/W	I	Read/Write Selection: read access when high, write access when low
35	WAITB	O ⁽³⁾	Data Acknowledge, active low
DATA INPUT INTERFACE			
First Serial Data Interface (I²S)			
37	DSTRB	I	Clock Input Data, active low
41	SIN	I	Serial Input Data
40	LRCLKIN	I	Word Clock for the Input
42	REQ	O	Handshake for the Data Transfer, configurable by the SIN_SETUP register
Second Serial Data Interface (I²S)			
62	DSTRB2	I	Clock Input Data, active low
60	SIN2	I	Serial Input Data
61	LRCLKIN2	I	Word Clock for the Input
63	REQ2	O	Handshake for the Data Transfer, active low
DATA OUTPUT INTERFACES			
69	PCMCLK	I/O	Oversampling Clock input for STA310 when generated externally
DAC Interface			
67	SCLK	O	Bit Clock for the DAC

2 STA310 AUDIO DECODER PIN DESCRIPTION (continued)

Pin Number	Name	Type	Function
68	LRCLK	O	Word Clock for the DAC
72	PCM_OUT0	O	Data from a Prologic downmix (VCR_L/VCR_R)
73	PCM_OUT1	O	Data for the first DAC (Left/Right)
76	PCM_OUT2	O	Data for the second DAC (Centre/Sub)
77	PCM_OUT3	O	Data for the third DAC (LeftSur/RightSur)
IEC958 Interface (S/PDIF) - One Output Port., One Input Ports.			
58	I958OUT	O	S/PDIF Signal
25	SPDP	I	First differential input of S/P DIF port
24	SPDN	I	Second differential input of S/P DIF port
26	SPDF	I	External Filter
28	VDDA	I	Analog VDD for S/P DIF Input port
29	GNDA	I	Analog GND for S/P DIF Input port
STATUS INFORMATION			
PCM Related Information			
54	SFREQ	O	Then high, indicates that the sampling freq. is either 44.1Khz or 22.05Khz. When low, indicates that the sampling frequency is either 32 Khz, 48 Khz, 24 Khz or 16Khz.
57	DEEMPH	O	Indicates if de-emphasis is performed.
Audio Video Synchronization			
59	PTSB	O	Indicates that a PTS has been detected, active low.
Other Signals			
31	CLK	I	Master Clock Input Signal.
36	RESET	I(2)	Reset signal input, active low.
52	TESTB	I(2)	Reserved pin: to be connected to VDD
49	SMODE	I	Reserved pin : to be connected to GND
RS232 Interface			
8	RS232RX	I	
9	RS232TX	O	
PLLs INTERFACES			
64	CLKOUT	O	System clock output with programmable division ratio
27	PLLAF	I	External Filter For Audio PLL.

STA310

2 STA310 AUDIO DECODER PIN DESCRIPTION (continued)

Pin Number	Name	Type	Function
30	PLLSF	I	External Filter For System PLL.
Power and Ground			
5 - 11 - 23 - 33 - 39 - 45 - 50 - 56 - 66 - 71 - 75	GND	GND	Ground
4 - 17 - 34 - 38 44 - 55 - 65 - 74	VDD	VDD	2.5V Power Supply
10 - 32 - 51 - 70	VDD3	VDD3	3.3V Power Supply

- Notes (1) Open Drain
 (2) Internal Pull-up
 (3) Tri-State

PIN CONNECTION (Top view)

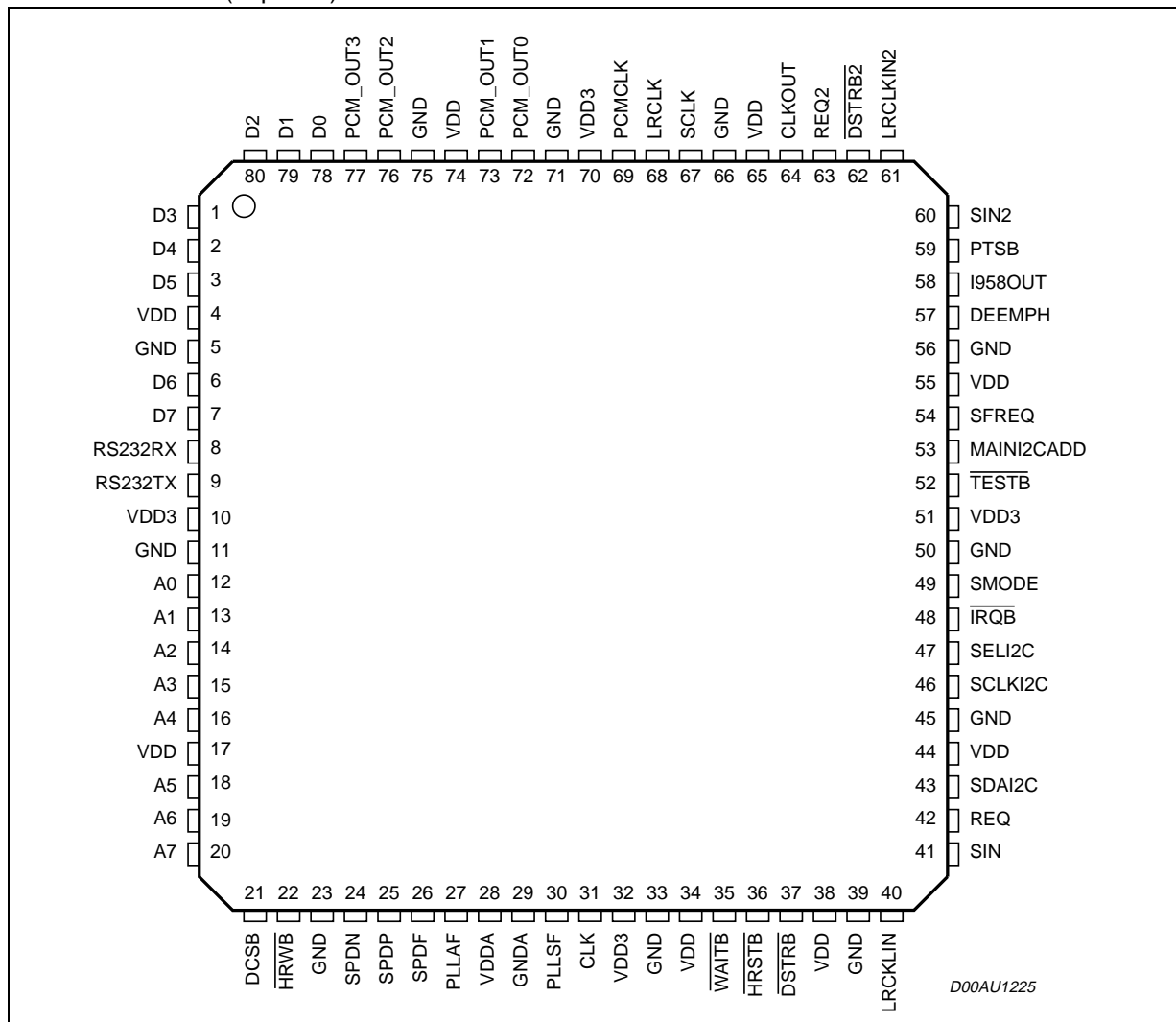

D00AU1225



ABSOLUTE MAXIMUM RATINGS

Symbol	Parameters	Value	Unit
Vdd	2.5V Power Supply Voltage	-0.5 to 3.3	V
	2.5V Input or Output Voltage	-0.5 to (Vdd+0.5)	V
Vdd3	3.3V Power Supply Voltage	-0.5 to 4	V
	3.3V Input or Output Voltage	-0.5 to (Vdd+0.5)	V

ELECTRICAL CHARACTERISTICS ($V_{DD} = 3.3V \pm 0.3V$; $T_{amb} = 0$ to $70^{\circ}C$; $R_g = 50 \Omega$ unless otherwise specified)

DC OPERATING CONDITIONS

Symbol	Parameters	Value	Unit
Vcc	Power Supply Voltage	2.5	V
Tj	Operating Junction Temperature	-20 to 125	$^{\circ}C$

GENERAL INTERFACE

Symbol	Parameters	Conditions	Min	Typ	Max	Unit	Note
I _{il}	Low level input current without pull-up device	V _i = 0V			1	μA	1
I _{ih}	High level input current without pull-down device	V _i = Vdd			1	μA	1
I _{oz}	Tri-state output leakage without pull-up/down device	V _i = 0V or Vdd			1	μA	1
I _{latchup}	I/O Latch-up current	V < 0V, V > Vdd	200			mA	2
Vesd	Electrostatic protection	Leakage < 1 μA	2000			V	3

Note: 1. The leakage currents are generally very small, < 1nA. The value given here, 1 μA , is a maximum that can occur after an Electrostatic Stress on the pin.

2. V > Vdd3 for 3.3V buffers.

3. Human Body Model

LVTTL & LVCMOS DC Input Specification 2.7V <Vdd3 <3.6V

Symbol	Parameters	Conditions	Min	Typ	Max	Unit	Note
V _{il}	Low level input voltage				0.8	V	1
V _{ih}	High level input voltage		2.0			V	1
V _{ilhyst}	Low level threshold input falling		0.8		1.35	V	1
V _{ihhyst}	High level threshold input rising		1.3		2.0	V	1
V _{hyst}	Schmitt trigger hysteresis		0.3		0.8	V	1

Note: 1. Takes into account 200mV voltage drop in both supply lines.

2. X in the source/sink current under worst case conditions and is reflected in the name of the I/O cell according to the drive capability

STA310

ELECTRICAL CHARACTERISTICS (continued)

Symbol	Parameters	Conditions	Min	Typ	Max	Unit	Note
I _{pu}	Pull-up current	V _i = 0V		-66	0.8	μA	1
R _{pu}	Equivalent Pull-up resistance	V _i = 0V		50		KΩ	

Note: 1. **Min condition:** V_{DD} = 2.7V, 125°C Min process **Max condition:** V_{DD} = 3.6V, -20°C Max

POWER DISSIPATION

Symbol	Parameters	Conditions	Min	Typ	Max	Unit	Note
P _D	Power Dissipation @V _{DD} = 2.4V	Sampling frequency ≤ 24KHz		t.b.d.		mW	1
		Sampling frequency ≤ 32KHz		t.b.d.		mW	1
		Sampling frequency ≤ 48KHz		t.b.d.		mW	1

INTRODUCTION

The STA310 is a fully integrated multi-format audio decoder. It accepts as input, audio data streams coded with all the formats listed above.

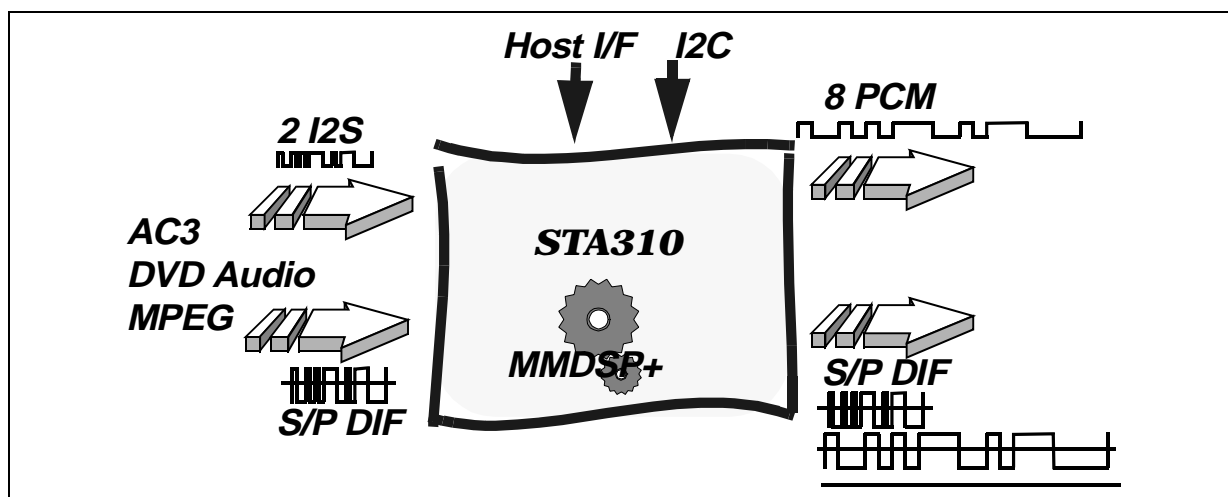

2.1 Inputs and Outputs

2.1.1 Data Inputs

- Through a parallel interface (shared with the control interface)
- Through a serial interface (for all the I²S formats)
- Through a S/P DIF (SPDIF or IEC-61937 standards).

- Through a second, independent, I²S (for application like i.e. Karaoke mixing).

2.1.2 Data outputs

- The PCM audio ooutput interface, which provide:
 - PCM data on 4 outputs:
 - Left/Right,
 - Centre/Subwoofer
 - Left Surround/Right Surround.

- Data From a Prologic downmix (encoder)
"Lrclk" "Sclk" "PcmClk"

- S/P DIF Output

2.1.3 Control I/F

I2C slave or parallel interface:

The device configuration and the command issuing is done via this interface. To facilitate the contact with the MCU, 2 interrupt lines (IRQB and INTLINE) are available.

3 ARCHITECTURE OVERVIEW

3.1 Data flow

The STA310 is based on a programmable MMDSP+ core optimized for audio decoding algorithms.

Dedicated hardware has been added to perform specific operations such as bitstream depacking or IEC data formatting.

The arrows in Figure 3 indicate the data flow within the chip.

The compressed bitstream is input via the data input interface.

Data are transferred on a byte basis to the FIFO. This FIFO allows burst input data at up to 33Mbit/s.

The input processor, which is composed of a packet parser and an audio parser, unpacks the bitstream (Packet parser) and verifies the syntax of the incoming stream (audio parser).

The compressed audio frames with their associated information (PTS) are stored into the circular frame buffer.

While a second frame is stored in the circular frame buffer, the first frame is extracted by the audio core decoder which decodes it to produce audio samples.

The PCM unit converts the samples to the PCM format. The PCM unit controls also the channel delay buffer in order to delay each channel independently.

In parallel, the IEC unit transmits non compressed data or compressed data according to the selected mode. In the compressed mode, the data are extracted directly from the circular buffer and formatted according to the IEC-61937 standard. In non compressed mode, the left and right PCM channels formatted by the PCM unit are output by the IEC unit, according to the SPDIF standard

Figure 1. Architecture and data flows

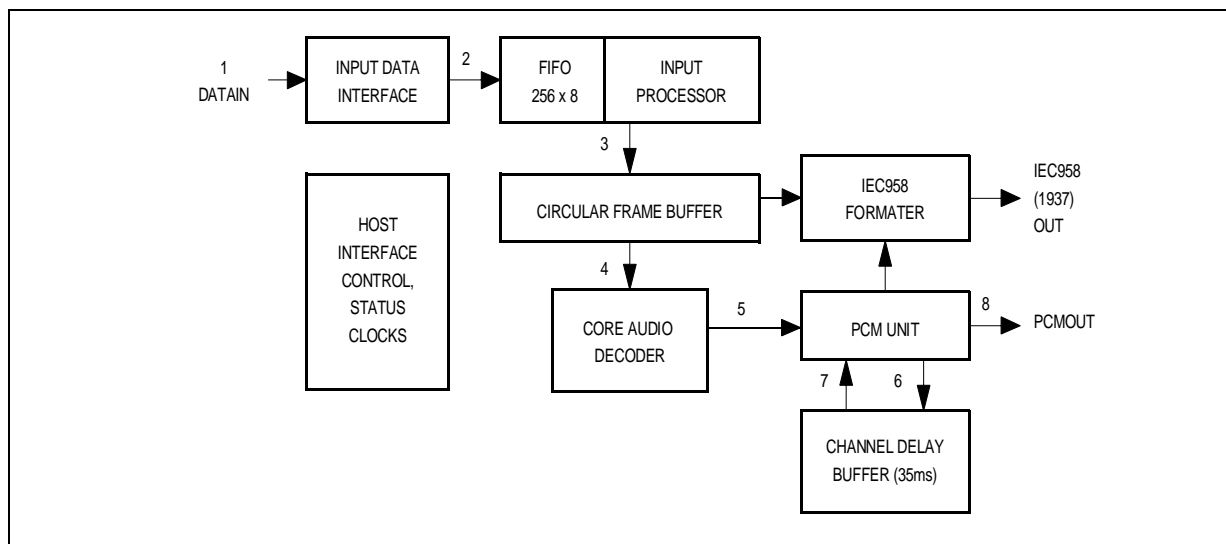

3.2 Functional diagram

Figure 2. Audio decoder top level functional diagram

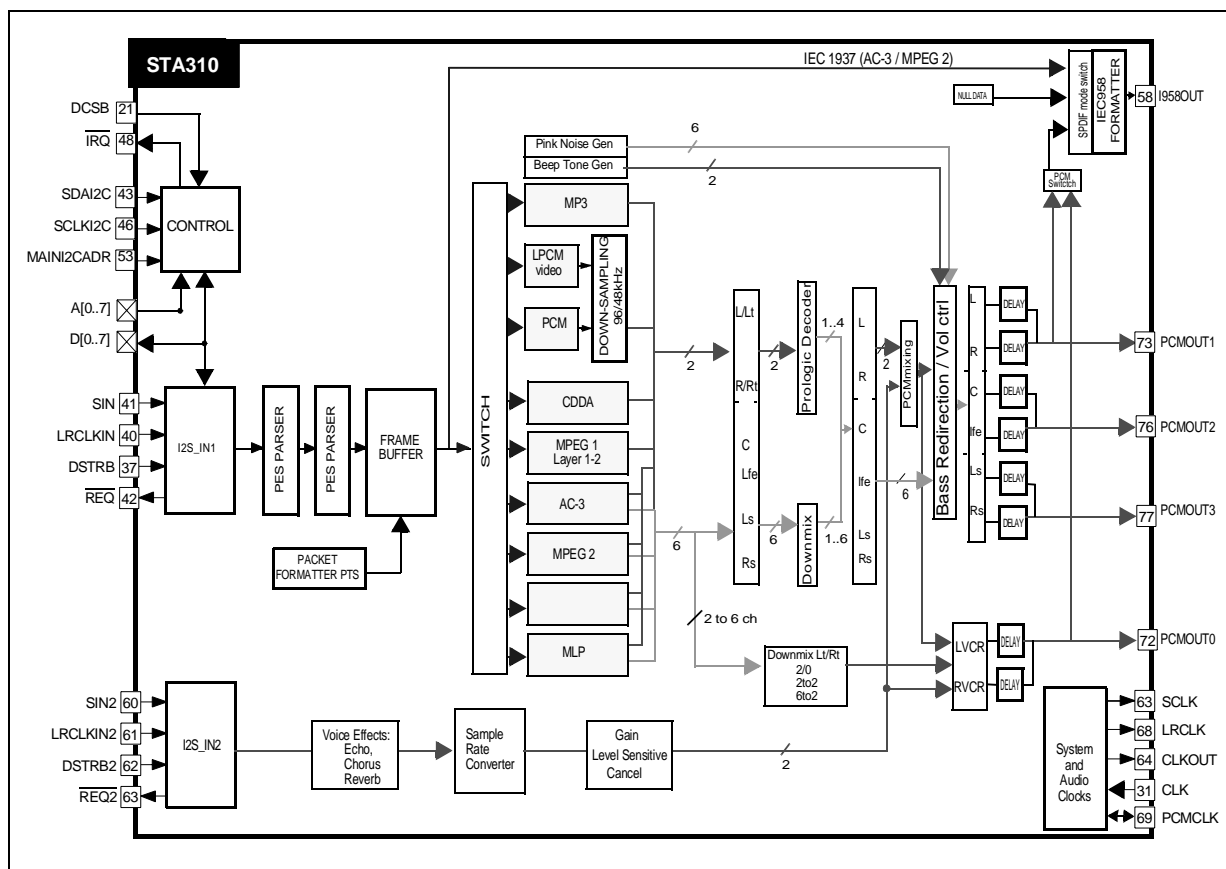

3.3 Control interface description

The IC can be controlled either by a host using an I²C interface, or by a general purpose host interface.

These interfaces provide the same functions and are described in the following sections. The selection is performed by the means of the pin SELI2C: when high, this pin indicates that the I²C interface is used. When low, the parallel interface is used.

3.3.1 Parallel control interface

When the pin SELI2C is low, the control of the chip is performed through the parallel interface. When accessing the device through the parallel interface, the following signals are used:

- The address bus A[7..0]. It is used to select one of the 256 register locations.
- The data bus DATA[7..0]. If a read cycle is requested, the data lines D[7:0] will be driven by the IC. For a write cycle, the STA310 will latch the data placed on the data lines when the WAIT signal is driven high.
- The signal R/W. It defines the type of register access: either read (when high), or write (when low). Some registers can be either written or read, some are read only, some are write only.
- The signal DCSB. A cycle is defined by the assertion of the signal DCSB.

Note: 1. The address bus A[7..0], and read/write signal R/W must be setup before the DCSB line is activated.



- The signal $\overline{\text{WAIT}}$. This signal is always driven low in response to the $\overline{\text{DCSB}}$ assertion.

The timing diagrams for the parallel control interface are given in *Electrical specifications* on page 5.

3.4 I²C control interface

When the pin SELI2C is high, the chip is controlled through the I²C interface. The I²C unit works at up to 400kHz in slave mode with 7-bit addressing.

- The Pin MAINI2CADR selects the device address. When MAINI2CADR is high the slave address is 0x5C, when low the device address is equal to the value on the address bus (A0...A6).
- The pin SDAI2C is the serial data line.
- The pin SCLKI2C is the serial clock.

The I²C Bus standard does not specify sub-addressing. There are thus potentially multiple ways to implement it. Any implementation that respects the standard is of course legal but a particular implementation is used by many companies. The following paragraphs describe this implementation.

3.4.1 Protocol description

For write accesses only, the first data which follows the slave address is always the sub-address.

This is the one and only way to declare the sub-address. It should be noticed that the sub-address is implemented as a standard data on the I²C Bus protocol point of view. It is a sub-address because the slave knows that it must load its address pointer with the first data sent by the master.

See in the Appendix X.x for I²C message format examples.

3.5 Decoding process

The decoding process in the STA310 is done in several stages:

- Parsing,
- Main decoding,
- Post decoding,
- Bass redirection,
- Volume and Balance control.

Each of the stages can be activated or bypassed according to the configuration registers.

Parsing

The bitstream parsing (performed by the input processor) is in charge of discarding all the non audio information in order to transmit to the next stage (the circular frame buffer) only the audio elementary stream (AC3, MPEG1/2, LPCM, PCM, DVD Audio).

The parsing stage operates in two phases: the packet parser unpacks the stream, the audio parser checks the syntax of the bitstream.

Main Decoding

The input of this stage is an elementary stream, the outputs are decoded samples. The number of output channels is defined by the downmix register (1 channel up to 6 channels). For details, please refer to the description of the register.

The decoding formats currently supported are AC3, MPEG1 layers I and II, MPEG2 layer II, LPCM. It is necessary to select the appropriate stream format by configuring the registers STREAMSEL and DECODESEL before running the decoder.

Post Decoding

The post decoding includes specific PCM processing: DC filter, de-emphasis filter, downsampling filter. These filters can be independently enabled or disabled through the register DWSMODE.

It provides also a Pro Logic decoder, which is described in detail in a next section.

Bass Redirection

This stage redirects the low frequency signals to the subwoofer.

The subwoofer is extracted from the other channels (L, R, C, Ls, Rs, LFe). There are six possible configurations to extract the subwoofer channel, which can be selected thanks to the OCFG register.

Volume and Balance Control

The volume is a master volume (no independent control for each channel). It is controlled by the PCMSCALE register, which enables to attenuate the signals by steps of 2dB.

Two balance controls are available: one for Left/Right channels, one for Left Surround/Right Surround channels. They are configurable by means of registers BAL_LR (Left-Right Balance) and BAL_SUR (Left Surround-Right Surround Balance), which provide attenuation of signals by steps of 0.5dB.

4 OPERATION

4.1 Reset

The STA310 can be reset either by a hardware reset or by a software reset:

- The hardware reset is sent when the pin $\overline{\text{RESET}}$ is activated low during at least 60ns. This is equivalent to a power-on reset.
This resets all the configuration registers, i.e. PLL registers (PLLSYS, PLLPCM), Interrupt registers (INTE, INT, ERROR), interface registers (SIN_SETUP, CAN_SETUP) and command registers (SOFTRESET, RUN, PLAY, MUTE, SKIP_FRAME, REPEAT_FRAME).
- The software reset is sent when the register SOFTRESET is written to 1 (the register is automatically reset once the software reset is performed). It resets only the interrupt related registers (INTE, INT, ERROR) and the command registers (SOFTRESET, RUN, PLAY, MUTE, SKIP_FRAME, REPEAT_FRAME). All other decoding configurations are not changed by softreset.

Some information concerning the post-processing are anywayt of date after a soft-reset

Note: 1. The chip must be soft reset before changing any configuration register.

4.2 Clocks

There are two embedded PLLs in the STA310: the system PLL and the PCM PLL.

The following is the block diagram of the system and audio clocks used in the STA310

Figure 3. PLL Block Diagram

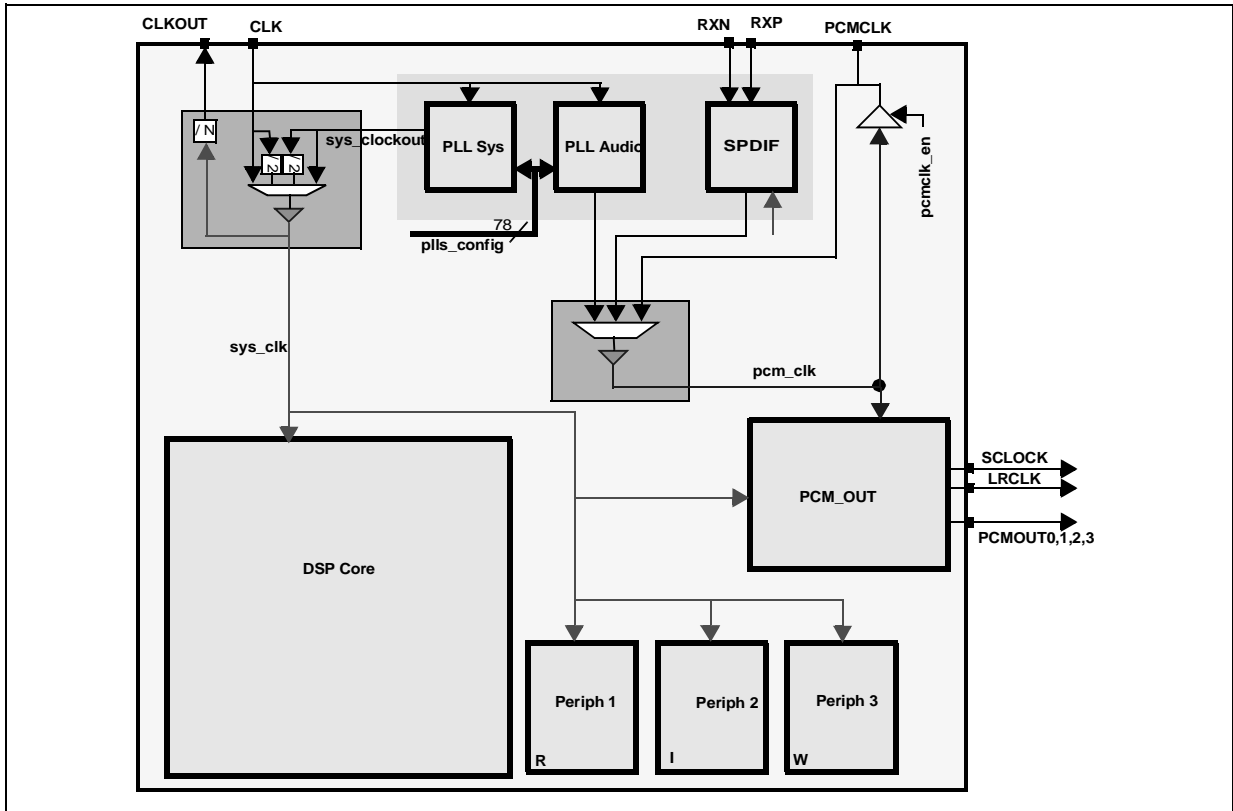
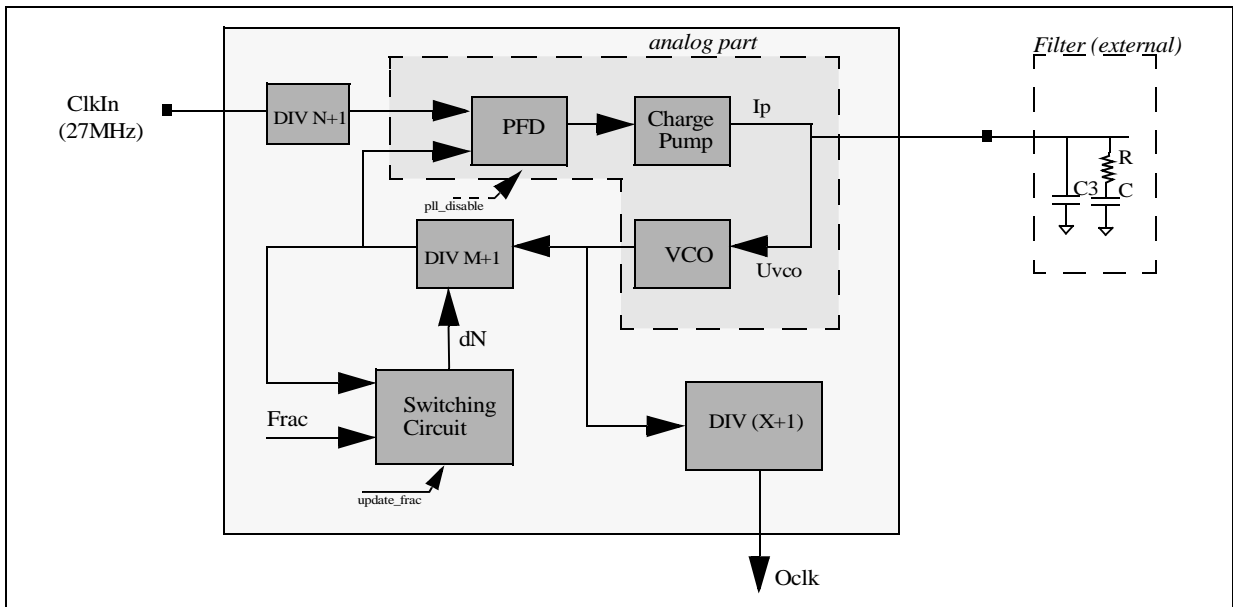

Figure 4. Block Diagram of Functional PLL



4.2.1 System clock

The system clock sent to the DSP core and the peripherals can be derived from 4 sources and the selection is performed through an Host Register; external clock, external clock divided by 2, internal system PLL and internal system PLL divided by 2.

The system PLL is used to create the system clock from the input clock. This PLL is software programmable through the Host Registers mechanism. The system PLL is used to set the any frequency up to the maximum allowed device speed. After hard reset the system clock is running at 47.25MHz. An RC network must be connected to the filter Pin PLLSF.

The system clock is output on the pin CLKOUT after a programmable divider ranging from 1 to 16.

4.2.2 DAC clocks

4.2.2.1 PCM clock

The PCM clock can be either input to the device or generated by the internal PLL or recovered by the embedded SPDIF receiver. The selection is done via the Host Registers.

After a hardware reset, the internal PLL is disabled and the PCMCLK pad is an input. PCMCLK may be equal to the PCM output bit rate, or it may be an integer multiple of this, allowing the use of oversampling D-A converters.

The internal fractional PLL is able to generate PCMCLK at any “FsX Oversampling Factor” frequencies, where Fs is any multiple or sub-multiple of the two 44.1kHz and 48kHz sampling frequencies. An RC network must be connected to the filter pin PLLAF; refer to External circuitry on page 9 for recommended values.

If the PCMCLK is recovered from the embedded SPDIF receiver, the only supported overampling frequency is 128 Fs.

4.2.2.2 Bit clock SCLK

The PCM serial clock SCLK is the bit clock. It provides clocks for each time slot (16 cycles for each channel in 16-bit mode, 32 cycles for each channel in 18-, 20-, 24-bit modes). The frequency of SCLK is therefore fixed to 2 x Nb time slots x Fs, where Fs is the sample frequency.

The clock is derived from the clock PCMCLK. The register PCMDIVIDER must be configured according to the selected output precision and the frequency of PCMCLK, so that the device can construct SCLK:

$$F_{sclk} = F_{pcmclk} / (2 \times (PCMDIVIDER + 1)) \text{ gives}$$

Table 1.

PCM Divider Value	Mode Description
5	PCMCLK = 384 Fs, DAC is 16-bit mode
3	PCMLK = 256 Fs, DAC is 16-bit mode
2	PCMLK = 384 Fs, DAC is 32-bit mode
1	PCMLK = 256 Fs, DAC is 32-bit mode

The value of PCMDIVIDER = 0 is reserved. If this number is loaded, the divider is bypassed and the frequency of SCLK equals the frequency of PCMCLK. The PCMDIVIDER register must be setup before the output of SCLK starts.

This can be done by first disabling PCM outputs, by de-asserting the MUTE and PLAY commands and then writing into the PCMDIVIDER register. Once the register is setup, the MUTE and/or PLAY commands can be asserted. PCMDIVIDER can not be changed “on the fly”.

4.2.2.3 Word clock LRCLK

The frequency of LRCLK is given by:

- $F_{lrclk} = F_{sclk}/32$; for 16 bit PCM output,
- $F_{lrclk} = F_{sclk}/64$; for 18, 20 or 24 bits PCM output.

No special configuration is required. The polarity can be changed in the register PCMCONF, by setting up the field INV as needed.

4.3 Decoding states

There are two different decoder states: Idle state and decode state (see <Blue HT>Figure 3). To change states, register

Figure 5. Decoding States

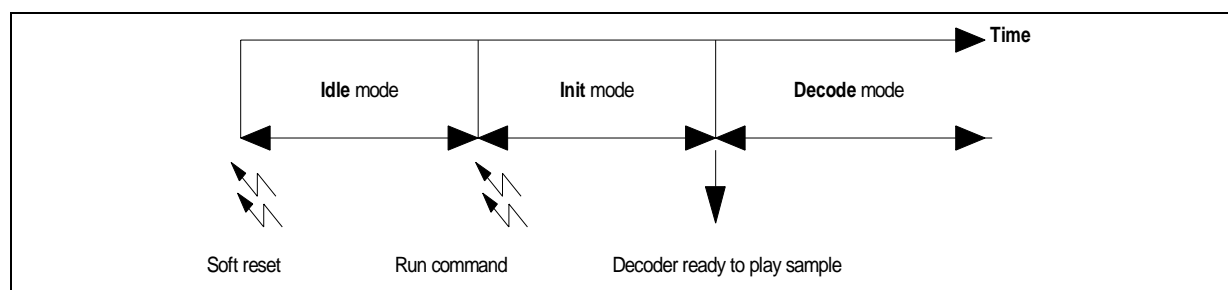

Idle Mode

This is the state entered after a hardware or software reset. In this state, the embedded DSP does not decode, i.e. no data are processed. The chip is waiting for the RUN command, and during this state all configuration registers must be initialized. In this state, even if the chip is not processing data, the DACs clocks can be output, which enables to setup the external DACs. Once the PCMCLK, SCLK and LRCLK clocks are configured, it is possible to output them by setting the MUTE register.

Table 2. Idle mode. play and mute commands effects

Play	Mute	Clock (SCLK, LRCLK) State	PCM Output
X	0	Not running	0
X	1	Running	0

Note: 1. The PLAY command has no effect in this state as the decoder is not running. It can however be sent and it will be taken into account as soon as the decoder enters the decode state.

Decode Mode

This state is entered after the RUN command has been sent (i.e. RUN register = 1). In this mode, the data are processed. The decoder can play sound, or mute the outputs, by using the PLAY and MUTE registers:

- To decode streams, the PLAY register must be set. When decoding, the sound will be sent to outputs if the MUTE register is reset. The outputs are muted if the MUTE register is set.
- To stop decoding, the PLAY register should be reset. Resuming decoding is performed by writing PLAY to 1 again

Two independent inputs are available on the STA310.

The main one allows to enter input data stream through through:

- A serial interface (referred to as Data Serial Interface),
- And a parallel interface (referred to as Data Parallel Interface).

The choice is performed by the register SIN_SETUP.

4.4.1 Data serial interface

When the serial mode is selected, the bitstreams can be entered into the STA310 through either:

- a four-signal data interface or ,
- trough a SPDIF input (no external circuit is required).

The four-signal data interface (see Figure 5) provides:

- An input data line SIN,
- An input clock \overline{DSTR} ,
- A word clock input LRCLKIN
- And a hand-shake output signal \overline{REQ} .

Note: 1. Only 16-bit PCM streams are supported. For 20-bit or 24-bit PCM, the 4 or 8 least significant bits are ignored

The specifications of those signals can be configured by the means of the register CAN_SETUP.

Two modes exist in serial mode, one that uses the LRCLKIN pin and one that does not use the LRCLKIN pin.

4.4.1.1 Modes without the LRCLKIN pin

In this mode the signal LRCLKIN is not used by the STA310. The input data SIN is sampled on the rising edge of DSTR. When the STA310 input buffer is full the REQ signal is asserted. The polarity of REQ signal is programmable through the register SIN_SETUP. The data must be sent most significant bits first.

When the decoder cannot accept further data the \overline{REQ} is de-asserted and the \overline{DSTR} clock must be stopped as soon as possible to avoid data loss. After the \overline{REQ} is de-asserted, the decoder is still able to accept data for a limited number of clock cycles.

The maximum number of data that can be transmitted with respect to the change of \overline{REQ} is given by the following formula: $N_{bits} = 23 - 6 * F_{DSTR}/33MHz$, where: F_{DSTR} is the \overline{DSTR} clock frequency, (max is 33 MHz).

4.4.1.2 Modes using the LRCLKIN pin

When receiving data from an A/D converter or from an S/PDIF receiver, the signal LRCLKIN is used.

The LRCLKIN signal is used to make the distinction between the left and right channels. Any edge of the LRCLKIN signal indicates a word boundary.

The data transfer between the input interface and the FIFO is done on a byte basis. After the edge (rising or falling) of the LRCLKIN, a new byte is transferred to the first stage of the STA310 every 8 \overline{DSTR} clock cycles.

If the number of time slots is not a multiple of 8, the remaining data is lost. The polarity of LRCLKIN and \overline{DSTR} is programmable.

The LRCLKIN can be delayed by one time slot, in order to support PCM delayed mode. All these configurations are programmable through the CAN_SETUP register.

The register CAN_SETUP has 4 significant bits, and each bit has a specific meaning, see *CAN_SETUP* on page 41.

Only the first byte is transferred to the STA310 because the number of time slots is 12 (8 + 4). SIN and LRCLKIN are sampled on the falling edge of DSTR In this case $SIN_SETUP = 3$ and $CAN_SETUP = LeftFirstChannel + FallingStrobe + AllSlot = 2 + 4 + 8 = 14$

Table 4.

	When Set	When Clear	Name
Bit 0	The input data is one slot delayed with respect to LRCLKIN	The input data is not delayed	DelayMode
Bit 1	First channel when LRCLKIN is set	First channel when LRCLKIN is reset	LeftFirstChannel
Bit 2	Data are sampled on falling edge of DSTR	Data are sampled on rising edge of DSTR	FallingStrobe
Bit 3	All the bytes are extracted	Only the first 16 data bits are extracted	AllSlot

Figure 7.

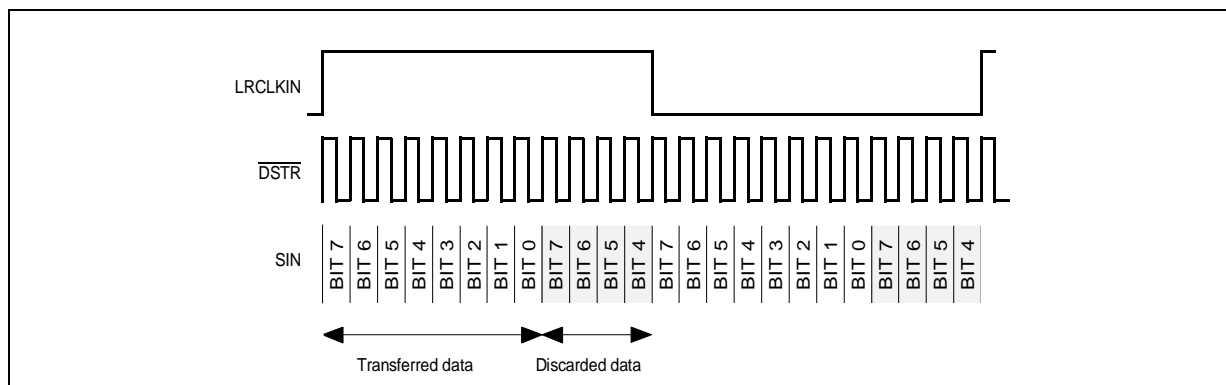

Example 2: Only the first 2 bytes are transferred to the STA310 because the number of slots is 20 (16 + 4). SIN and LRCLKIN are sampled on the falling edge of DSTR. The data is in delayed mode. The register configuration is SIN_SETUP=3 and CAN_SETUP = DelayMode + LeftFirstChannel + FallingStrobe + AllSlot = 1 + 2 + 4 + 8 = 15. This mode is a specific mode where only the first 16 data bits are transferred. The remaining bits are discarded. The register configuration is SIN_SETUP = 3 and CAN_SETUP = DelayMode + FallingStrobe = 1 + 4 = 5.

4.4.1.3 SPDIF Input

A true SPDIF Input **SPDIF** (PCM audio samples) or **IEC-61937** (compressed data) is selectable as a main serial input.

4.4.1.4 Autodetected formats

The STA310 cut 2.0 is able the following audio format changes on the s/pdif input

Table 5. Audio Format detection

BEFORE	AFTER
AC3	PCM
AC3	MPEG
MPEG	AC3
MPEG	PCM
PCM	AC3
PCM	MPEG

4.4.1.5 Second Input

A second independent input allows to input bitstreams in serial mode.

This second input can be used, to input audio stream from a microphone, while we decode a data stream trough the main input.

4.4.2 Data parallel interface

Two ways are available to input data in parallel mode:

- Either through the parallel data bus, shared with the external controller,
- Or through the DATAIN register

4.4.2.1 Using the parallel data bus

In this mode the data must be presented on the 8-bit parallel host data bus D[7..0]. Note that this bus is shared with the external controller. On the rising clock of \overline{DSTR} the data byte is sampled by the STA310. The signal \overline{REQ} is used to signal when the input FIFO is full. When \overline{REQ} is de-asserted the transfer must be stopped to avoid data loss.

After the \overline{REQ} is de-asserted, the decoder is still able to accept data for a limited number of clock cycles.

The maximum number of data that can be transmitted with respect to the change of \overline{REQ} is given by the following formula: $Nbits = 23 - 6 * F_{DSTR}/33MHz$, where: F_{DSTR} is the \overline{DSTR} clock frequency, (max is 33 MHz).

The signals \overline{DSTR} and \overline{DCSB} are used to make the distinction between Stream Data (strobed by \overline{DSTR}) and Control Data (strobed by \overline{DCSB}). To avoid conflicts, the \overline{DSTR} signal and the \overline{DCSB} signal must respect given timing constraints.

4.4.2.2 Using the DATAIN register

The data can be input by using the control parallel interface as if accessing any other register.

The signal \overline{DCSB} is therefore used. When using this register to input data stream, there is no need to byte-align the data.

Figure 8.

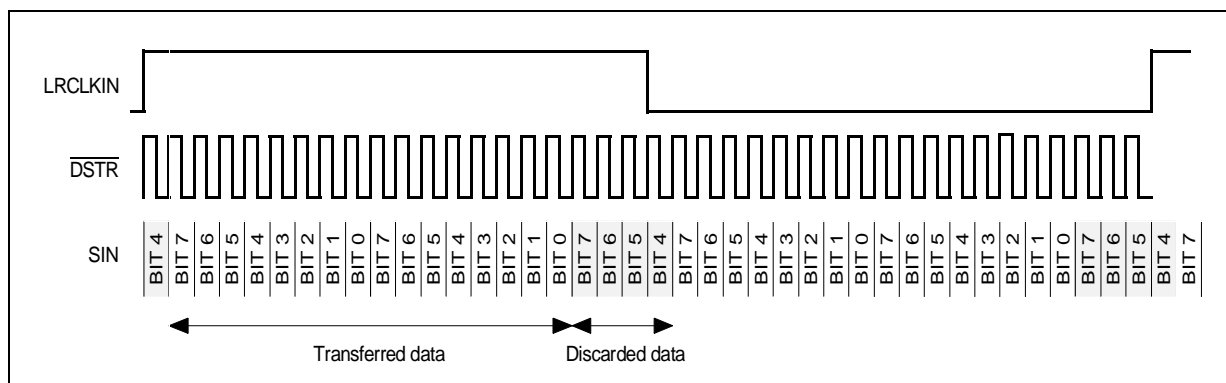
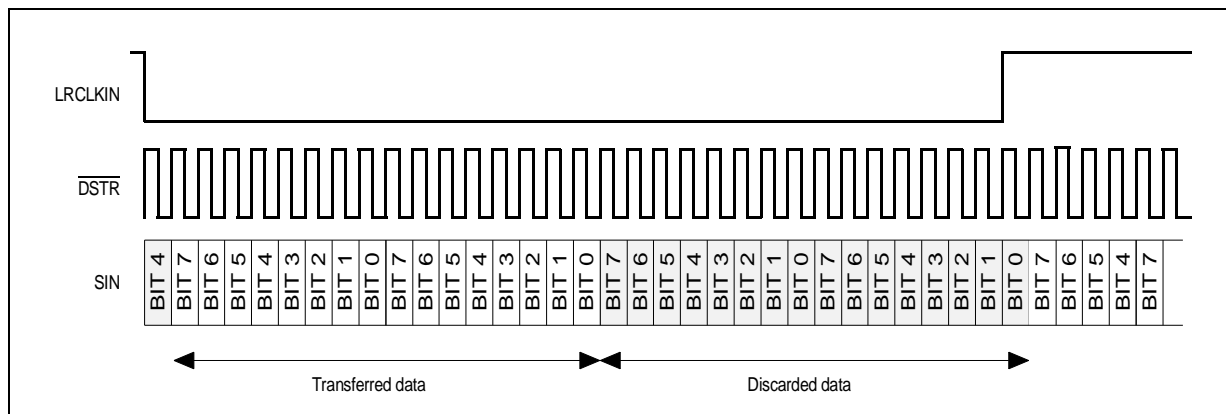

Figure 9.



4.5 Streams parsers

The parsing stage is operated by two parts: the packet parser and the audio parser.

The packet parser unpacks stream, sorts packets and transmit data to the audio parser. The audio parser verifies the stream syntax, extracts non-audio data and sends audio data to the frame buffer.

Packet parser

Before unpacking packets and transmitting data, the packet parser needs to detect the packet start by recognizing the packet synchronization word. It is possible to force the parser to search for two packet synchronization words before starting to unpack and transmit.

This is done by setting the register PACKET_LOCK to 1. Otherwise, the packet parser will start handling the stream once it has detected information matching the packet synchronization word.

The packet parser is also able to perform selective decoding: it can decode audio packets that are matching a specified Id. This Id is specified in AUDIO_ID and AUDIO_ID_EXt registers, and the function is enabled by setting the AUDIO_ID_EN register.

Audio parser

The audio parser needs to detect the audio synchronization word corresponding to the type of stream that must be decoded. It is possible to force the audio parser to detect more than one synchronization word before parsing.

This is done by setting the SYNC_LOCK register to a value between 1 and 3 - number of supplementary sync words to detect before considering to be synchronized.

The status of synchronization of both parsers is provided in the register SYNC_STATUS. Each time the synchronization status of one of the two parsers changes, the interrupt SYN is generated (if enabled) and the status can be read in SYNC_STATUS.

4.6 Decoding modes

4.6.1 AC-3

The STA310 is Dolby Digital certified for class A products. The decoder must be programmed so to specify the stream format as AC-3 encoded: register DECODESEL = 0.

In the sections below are provided the modes specific to the AC-3 decoding.

4.6.1.1 Compression modes

Four compression modes are provided in the STA310:

- Custom A (also named custom 0 in Dolby specifications),
- Custom D (also named custom 1 in Dolby specifications),
- Line mode,
- RF mode.

These modes refer to different implementation of the dialog normalization and dynamic range control features. The mode is selected by programming the register COMP_MOD to the appropriate value.

Line Mode

In Line Mode (COMP_MOD = 2), the dialog normalization is always enabled. It is done by the decoder itself and the dialog is reproduced at a constant level.

The dynamic range control variable encoded in the bitstream is used and can be scaled by the two scaling registers HDR (for high-level cut compression) and LDR (for low-level boost compression). In case of 2/0 downmix, the high-level cut compression is not scalable.

RF Mode

In RF Mode (COMP_MOD=3), the dialog normalization is always performed by the decoder. The dialog is reproduced at a constant level.

The dynamic range control and heavy compression variables encoded in the bitstream are used, but the compression scaling is not allowed. This means that the HDR and LDR registers can not be used in this mode. A +11dB gain shift is applied on the output channels.

Custom A Mode

In Custom A mode (COMP_MOD=0), the dialog normalization is not performed by the decoder and must be done by another circuit externally.

The dynamic range control variable encoded in the bitstream is used and can be scaled by the two scaling registers HDR (for high-level cut compression) and LDR (for low-level boost compression).

Custom D Mode

In Custom D mode (COMP_MOD=1), the dialog normalization is performed by the decoder. The dynamic range control variable encoded in the bitstream is used and can be scaled by the two scaling registers HDR (for high-level cut compression) and LDR (for low-level boost compression).

4.6.1.2 Karaoke mode

The AC-3 decoder is karaoke aware and capable.

A karaoke bitstream can be composed of 5 channels: L for Left, R for Right, M for guide Melody, V1 for vocal track 1 and V2 for Vocal track 2.

- When in karaoke aware mode, the channels L,R and M are reproduced, and the channels V1 and V2 are reproduced at a level fixed by the bitstream.
- When in karaoke capable mode, it is possible to choose to reproduce one, two or none of the two incoming vocal tracks, V1 and V2.

The karaoke decoder is activated by the use of KARAMODE register, which specifies the downmix for the different modes. This register replaces DOWNMIX register. It is however possible to consider the incoming karaoke channels as any other multichannel stream and output it with a downmix specified in DOWNMIX register. For details, refer to the Digital Audio Compression AC-3 ATSC standard, annex C.

4.6.1.3 Dual Mode

The Dual Mode corresponds to a mode where two completely independent mono program channels (e.g. bilingual) are encoded in the bitstream, referenced to as channel 1 and channel 2.

The possible ways to output channels on left/right outputs are:

- Output channel 1 on both L/R outputs,
- Output channel 2 on both L/R outputs,
- Mix channels 1 and 2 to monophonic and output on both L/R,
- Output channel 1 on Left output, and channel 2 on Right output.

This channels downmix is specified in the register DUALMODE.

4.6.2 MPEG

The STA310 is able to decode MPEG-1 layerI and layerII encoded data, as well as MPEG-2 layer I, layer II data without extension (i.e. 2-channel streams).

The MPEG input format should be specified in the DECODESEL register:

- DECODESEL=1 for MPEG1. The MC bit in MC_OFF register should be set.
- DECODESEL=2 for MPEG2. The MC bit in MC_OFF register should be set.

4.6.3 MP3

The STA310 is able to decoder MPEG2 layer III (MP3) data.

The MP3 input format aboved be specified in the DECODESEL register:

- DECODESEL=9 for MP3.

4.6.3.1 Dual Mode

The Dual Mode corresponds to a mode where two completely independent mono program channels (e.g. bilingual) are encoded in the 2-channel incoming bitstream, referenced to as channel 1 and channel 2.

The audio decoder allows to:

- Output channel 1 on both L/R outputs,
- Output channel 2 on both L/R outputs,
- Mix channels 1 and 2 to monophonic and output on both L/R,
- Output channel 1 on Left output, and channel 2 on Right output.

The output configuration is chosen by special downmix for dual mode through register MPEG_DUAL.

4.6.3.2 Decoding flow

Figure 10. AC-3 Decoding Flow

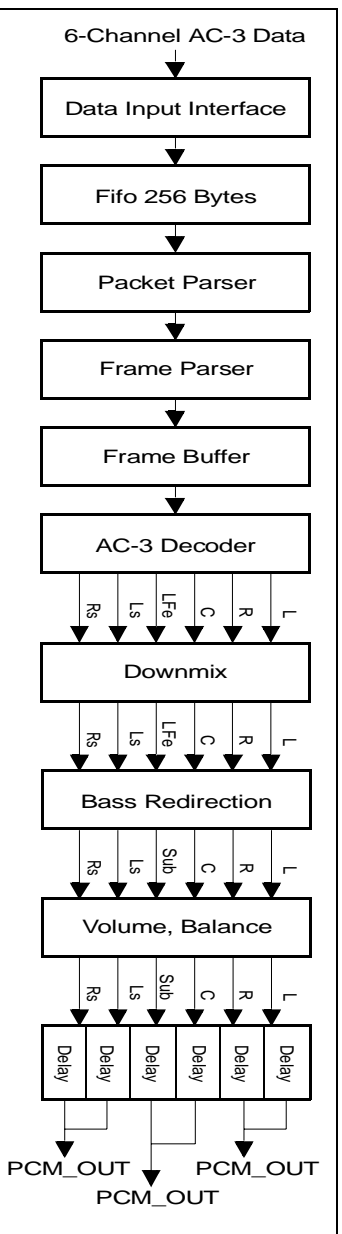
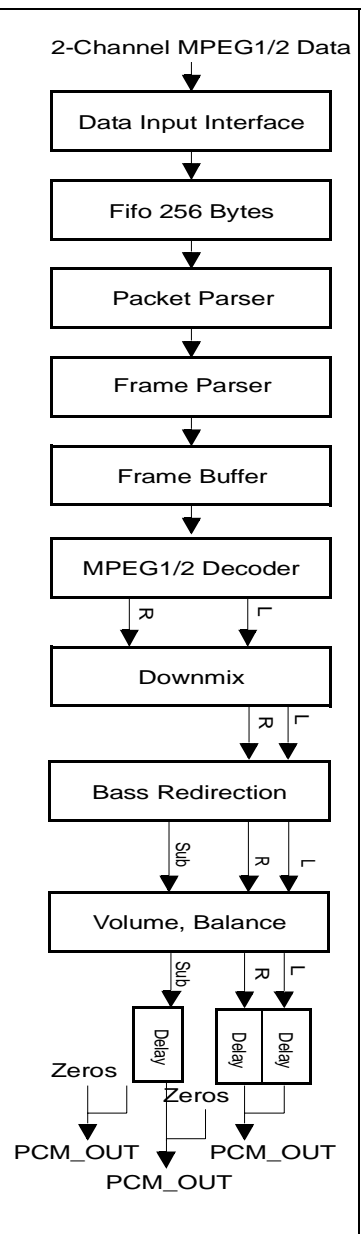

Figure 11. MPEG Decoding Flow



4.6.4 PCM/LPCM

The decoder supports PCM (2-channels) and LPCM Video (8-channels) and Audio (6-channels) streams. This is selected by DECODESEL=3.

4.6.4.1 Downsampling filter

When decoding PCM/LPCM streams encoded at 96kHz, it is possible to use a filter that downsamples the stream from 96kHz to 48kHz. The chip can not output streams at 96kHz. The register DWSMODE is used to configure the use of this filter.

Figure 12. PCM/LPCM Decoding flow

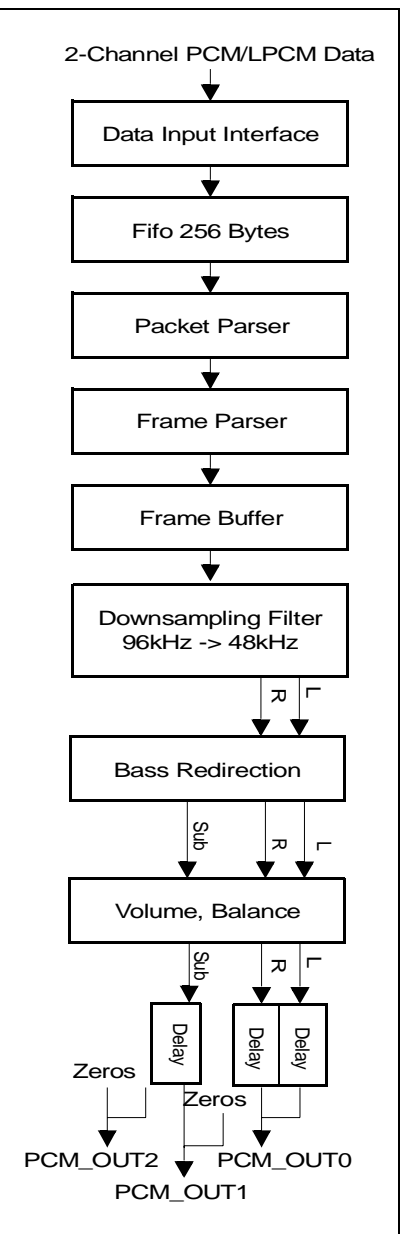

4.6.5 MLP

MLP is a lossless coding system for use on digital audio data originally represented as linear PCM. MLP is mandatory in DVD Audio. It allows transmission and storage of up to 6 channels. each up to 24 bits precision and with sample rates between 44.1 KHz and 192KHz.

- DECODESEL = 8

4.6.6 CDDA

- DECODESEL = 5

4.6.7 Beep Tone

- DECODESEL = 7

4.6.8 Pink noise generator

The pink noise generator can be used to position the speakers in the listening room so to benefit of the best listening conditions.

The decoder must be programmed so to generate pink noise by writing 4 in the DECODESEL register. The DOWNMIX register is used to select independently the channels on which the pink noise will be output.

When generating pink noise, the output configuration should be: OCFG=0 and PCM_SCALE=0.

Figure 13. Pink Noise Generator Flow

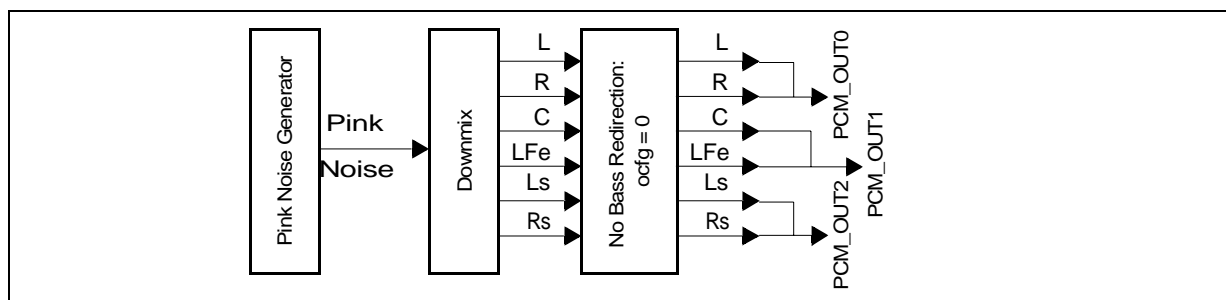

4.7 Post Processing

The following post processing algorithms are available

4.7.1 Prologic

Pro Logic Compatible Downmix

The STA310 can decode an AC-3 multichannel bitstream and encode it to provide a 2-channel Pro Logic compatible output (Lt, Rt). These 2 channels are the result of a specific downmix referred to as Pro Logic compatible. This downmix is selected by the register DOWNMIX. The 2 channels can be used as the input of a Pro Logic decoder and player (e.g. home theatre).

Pro Logic Decoding

The STA310 can decode a 2-channel Pro Logic bitstream. The 2 channels could come from a CD player, an AC-3 2-channel bitstream or an MPEG1 bitstream. The 2-channel bitstream can be converted into a 4-channel output (L, R, C, S). The surround (S) is simultaneously sent on Ls and Rs channels. A Pro Logic downmix en-

ables to configure which channels to output on PCM data. This is done through the register PL_DWN.

An auto-balance feature is available and activated through PL_AB register. The delay on surround channel is configurable thanks to the LSDLY register (while resetting the RSDLY register).

The bass redirection is performed after the Pro Logic decode. The same bass redirection configuration than those available in non-Pro Logic modes can be used except that the surround channels will not be added to the bass redirection. In the case of AC-3 or MPEG the STA310 is therefore capable of first decoding the AC-3 or MPEG stream then performing the Pro Logic decode.

4.7.2 Others

- Karaoke system
- Bass Management + Volume Control
- Deemphasis
- DC Remove

4.8 How to choose a decoder

To set up the device you have to select two registers.

The first one is DECODESEL for Audio data type,

The second one is STREAMSEL for Transport data type,

The STREAMSEL can be set-up as follows:

- 0= PES
- 1= PES DVD Video
- 2= Packet MPEG1
- 3= Elementary stream or IEC.60958
- 4= reserved
- 5= IEC.61937
- 6= PES DVD Audio

So the possible configurations on listed in the following table:

Table 6. Possible configurations:

STREAMSEL	DECODESEL	MODE
0	0	MPEG2 PES carrying Dolby Digital (ATSC)
0	1	MPEG2 PES carrying MPEG1 frames
0	2	MPEG2 PES carrying MPEG2 frames
1	0	MPEG2 PES carrying Dolby Digital frames for DVD Video
1	2	MPEG2 PES carrying MPEG2 frames for DVD Video
1	3	MPEG2 PES carrying Linear PCM frames for DVD Video
1	1	MPEG1 packet carrying MPEG1 frames
3	0	Dolby Digital frame elementary streams
3	1	MPEG1 frame elementary streams
3	2	MPEG2 frame elementary streams
3	3	Stereo PCM (16bits samples)
3	4	Pink Noise Generator

STREAMSEL	DECODESEL	MODE
3	5	CDDA frames
3	7	Beep Tone Generator
3	9	MP3 frame elementary streams
5	0	IEC61937 Input with Dolby Digital frames
5	1	IEC61937 Input with MPEG1 frames
5	2	IEC61937 Input with MPEG2 frames
6	3	MPEG2 PES carrying Linear PCM for DVD Audio
6	8	MPEG2 PES carrying MPL for DVD Audio

4.9 How to Program a Post Processing

4.9.1 2 registers for the mode:

PDEC (0x62) to define the type of PostProcessing

PDEC	MODE
0x01	Prologic
0x02	MPEG 1/2 Dynamic Range
0x08	Double Stereo
0x10	DC Remove
0x20	Deemphasis filter

4.9.2 1 or 2 registers to control the “PostProcessing”

Prologic decoder (PDEC = 0x01):

PL ABL WS (0x64)	Effect
1	AutoBalance
2	WideSurround
PL DOWNMIX (0x65)	Prologic DownMix
0,1,2	Prologic not applied
3	3/0 (L, R, C)
4	2/1 (L, R, Ls) Phantom
5	3/1 (L, R, Ls)
6	2/2 (L, R, Ls, Rs) Phantom
7	3/2 (L, C, R, Ls, Rs)

Remark: When playing “Dolby Digital Prologic encoded”, if PL_DOWNMIX is correctly set, Prologic decoder’ is automatically applied even if the register “PDEC” different to 1.



4.10 What Can Be Processed at the Same Time
Same Time 1

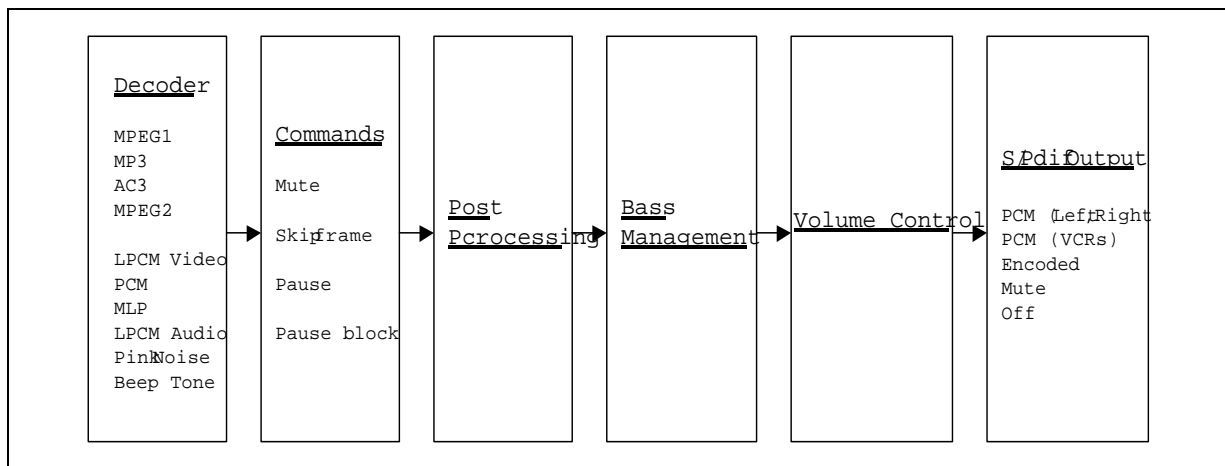

Same Time 2

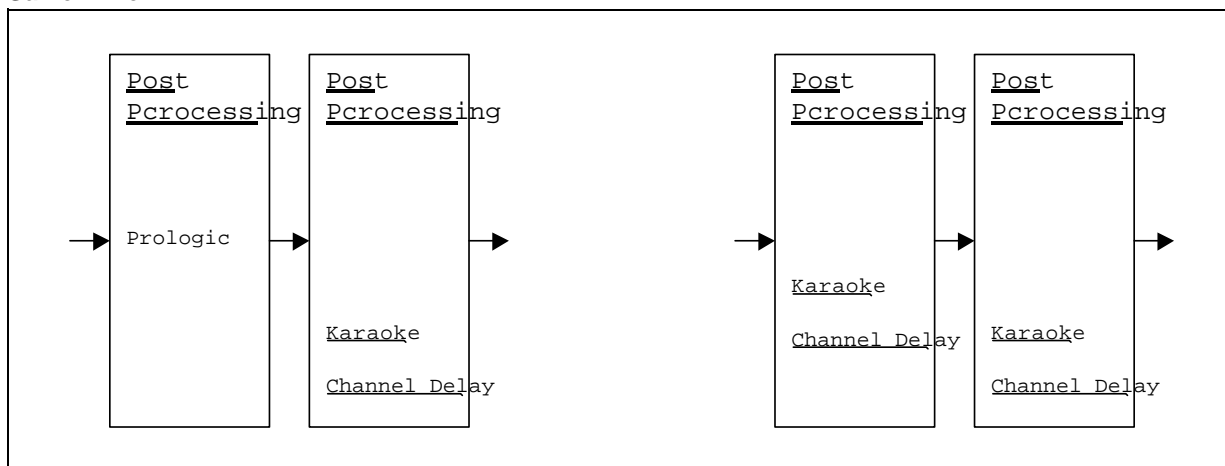

5 PCM OUTPUT CONFIGURATIONS

5.1 Output configurations

The figure below shows the different configurations supported at PCM output stage. They are selected by the OCFG register contents.

- In configuration 1, 3 and 4, the main channels are attenuated by 18.5dB, and the LFE by 8.5dB before summing.
 After digital/analog conversion, the subwoofer preamplifier has to compensate for the different gains of the main channels and subwoofer.
- In configuration 2, the main channels are attenuated by 16dB and the LFE by 6dB before processing.
- In configuration 0, outputs are only scaled and rounded (see next section).

The same configurations will be used in case of a decoded Pro Logic program with the exception that the surround channels will not be added to the bass redirection (the surround channels of a Pro Logic program are band limited and bass is considered as leakage).

Figure 14. PCM Output Configurations

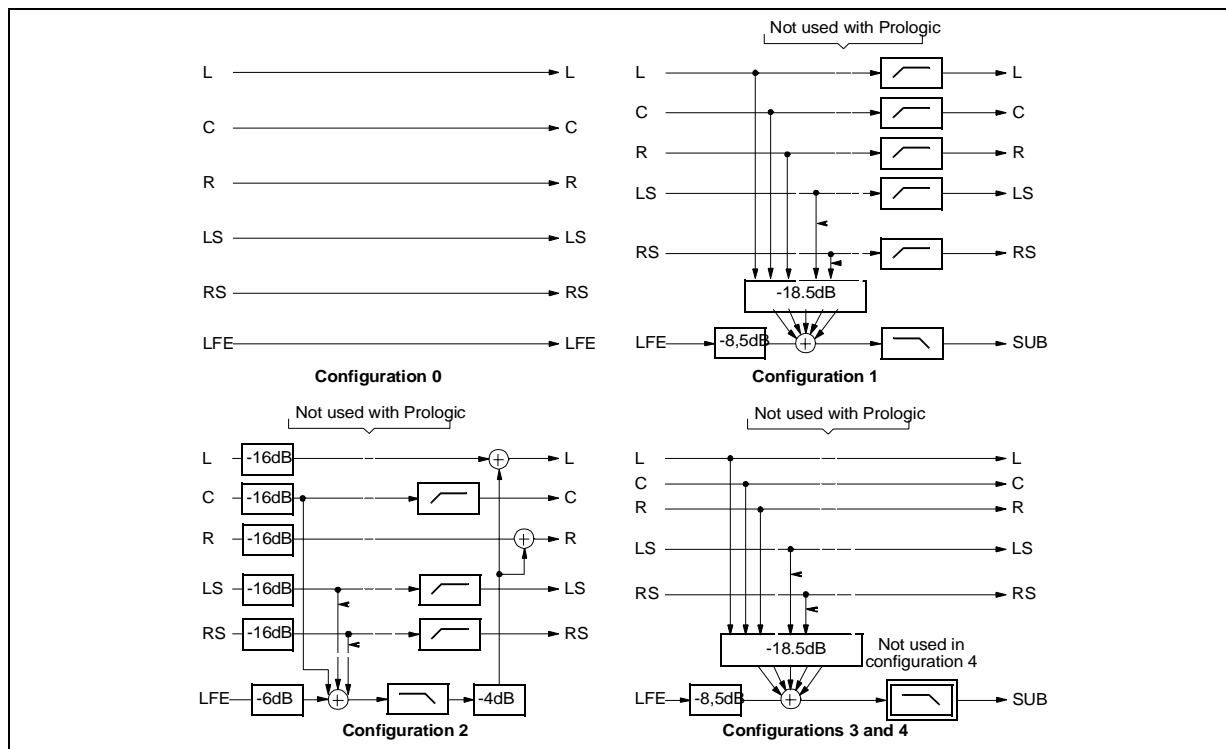

5.2 PCM scaling

PCM scaling is needed for every decoding mode (AC3, Pro Logic, MPEG, PCM). It is applied at the end of the filtering steps before PCM output, allowing maximum effective word width for most of the signal processing before.

Master volume (PCM_SCALE register) and balances (BAL_LR and BAL_SUR registers) are implemented for PCM scaling.

5.3 Output quantization

For optimal results for 16/18/20-bit DACs, a quantization with rounding is applied together with the PCM scaling. The sample value is multiplied by a rounding factor and rounded to 24 bits. The result is then left shifted (4/6/8) for PCM output.

The output precision is selectable from the 16bits/word to 24 bits/word by configuring the field PREC in the register PCMCONF.

5.4 Interface and output formats

The decoded audio data are output in serial PCM format.

The interface consists of the following signals

- PCM_OUT0, 1, 2 PCM data, output,
- SCLK Bit clock (or serial clock), output,
- LRCLK Word clock (or Left/Right channel select clock), output,
- PCMCLK PCM clock, input or output (see <CrossRef><BlueHT>Clocks <BlueHT>on page 11 for details).

5.4.1 Output precision and format selection

Output precision is selectable from 16 bits/word to 24 bits/word by setting the output precision select, in the PCMCONF (16-, 18-, 20- and 24-bit mode) register.

In 16-bit mode, data may be output either with the most significant bit first or least significant bit first. This is configured by the contents of the field ORD in the PCMCONF register.

When PCMCONF.PREC is more than 16 bits, 32 bits are output for each channel. In this configuration, the field FOR of register PCMCONF is used to select Sony or I²S- compatible format. The field DIF of PCMCONF is used to position the 18, 20 or 24 bits either at the beginning or at the end of each 32-bit frame.

Figure 15. Output formats

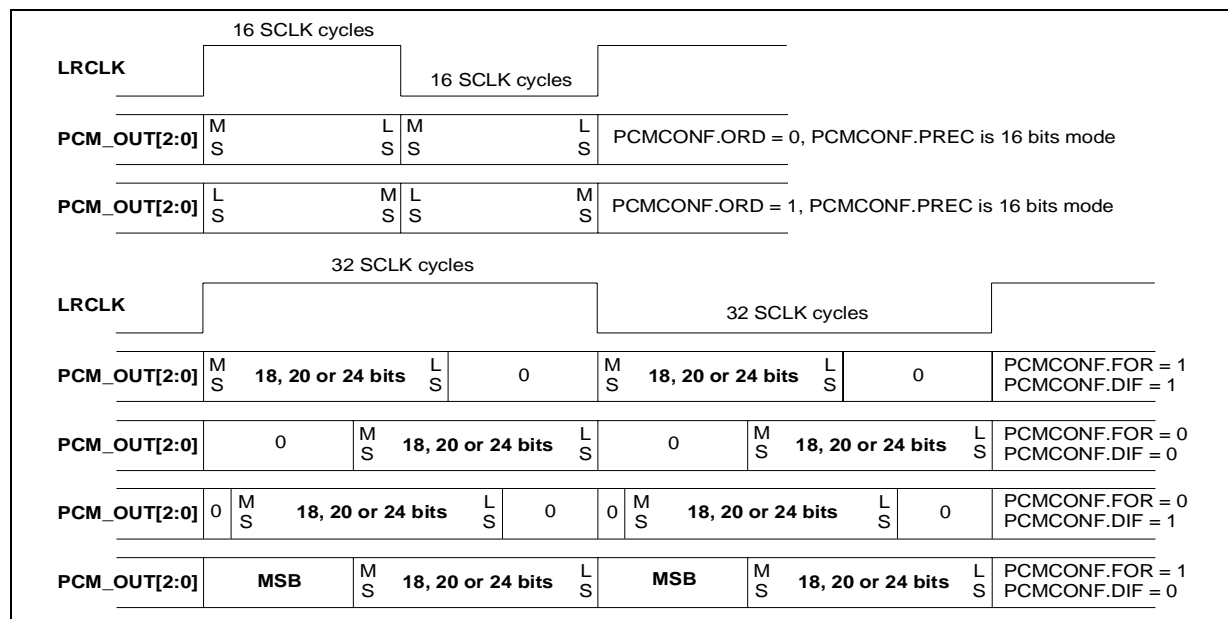

M CONF.PEC	PCM CONF.ORD	PCM CONF.FOR	PCM CONF.DIF	DATA IN SAMPLE MEMORY DATA [23:0]	DATA SENT ON THE PCM SERIAL OUTPUT (LEFT BIT FIRST)
0:16-bit mode	1	NA	NA	{d23-d8}-{8*0}	{d8-d23}: 16 bits
0:16-bit mode	0	NA	NA	{d23-d8}-{8*0}	{d23-d8}: 16 bits
1:18-bit mode	NA	0	0	{d23-d6}-{6*0}	{13*0}{0}{d23-d6}: 32 bits
1:18-bit mode	NA	0	1	{d23-d6}-{6*0}	{0}{d23-d6}{13*0}: 32 bits
1:18-bit mode	NA	1	0	{d23-d6}-{6*0}	{14*d23}{d26*d6}: 32 bits
1:18-bit mode	NA	1	1	{d23-d6}-{6*0}	{d23-d6}{14*0}: 32 bits
2:20-bit mode	NA	0	0	{d23-d4}-{4*0}	{11*0}{0}{d23-d4}: 32 bits
2:20-bit mode	NA	0	1	{d23-d4}-{4*0}	{0}{d23-d4}{11*0}: 32 bits
2:20-bit mode	NA	1	0	{d23-d4}-{4*0}	{12*d23}{d23-d4}: 32 bits
2:20-bit mode	NA	1	1	{d23-d4}-{4*0}	{d23-d4}{12*0}: 32 bits
3:24-bit mode	NA	0	0	{d23-d0}	{6*0}{0}{d23-d0}: 32 bits
3:24-bit mode	NA	0	1	{d23-d0}	{0}{d23-d0}{7*0}: 32 bits
3:24-bit mode	NA	1	0	{d23-d0}	{8*d23}{d23-d0}: 32 bits
3:24-bit mode	NA	1	1	{d23-d0}	{d23-d0}{8*0}: 32 bits

How to read the above table:

The first 4 columns list the possible configurations for output formats on the PCM outputs. The 5th column gives the description of the internal 24-bit decoded, scaled and rounded audio samples as they are stored in memory. These 24 bits are referred to as d23, d22,..., d0, where MSB=d23, LSB=d0. The last column describes the sequence of bits that are output on PCM_OUT according to the selected format.

Example 1: in 16-bit mode, with PCMCONF.ORD=1: In memory, 24 bits are stored, where only the 16 MSB bits (d23, d22,... to d8) are significant and the 8 remaining bits are 0. This is noted: {d23-d8} {8*0}. The data are sent LSB first, i.e. d8 is sent first and d23 is sent last. This is noted {d8-d23}. 16 bits only are transmitted per channel.

Example 2: in 20-bit mode (PCMCONF.ORD field is meaningless in this mode), with PCMCONF.FOR=1 and PCMCONF.DIF=0: In memory, 24 bits are stored, where only the 20 MSB (d23 to d4) are significant and the remaining 4 LSB are 0. This is noted: {d23-d4} {4*0}. 32 bits are transmitted per channel on the PCM outputs: the 12 first transmitted bits are d23, the last bits are d23 to d4, where d23 is transmitted first. This is noted: {12*d23} {d23-d4}.

5.4.2 Clocks polarity selection

The polarity of the PCM serial output clock, SCLK and the polarity of the PCM word clock LRCLK are selected by the field SCL and INV respectively, in the PCMCONF register.

5.4.3 I²S format compatible outputs

To output I²S compatible data, the PCMCONF register must be configured as follows

PCMCONF.DIF	= 1	not right padded,
PCMCONF.FOR	= 0	I ² S format,
PCMCONF.INV	= 0	do not invert LRCLK,
PCMCONF.SCL	= 0	do not invert SCLK.

5.4.4 Sony format compatible outputs

PCMCONF.FOR	= 1	Sony format,
PCMCONF.INV	= 1	Invert LRCLK.

Figure 16. SCLK Polarity

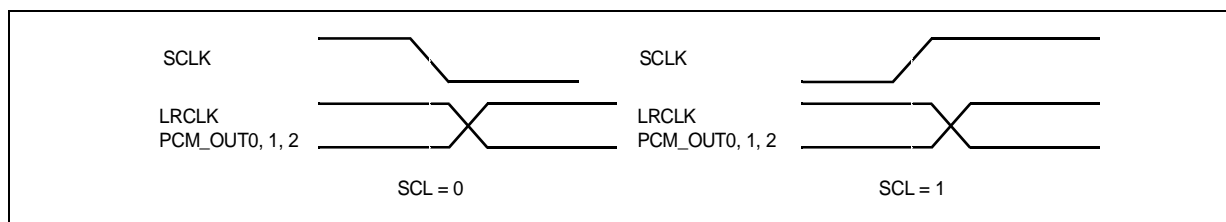
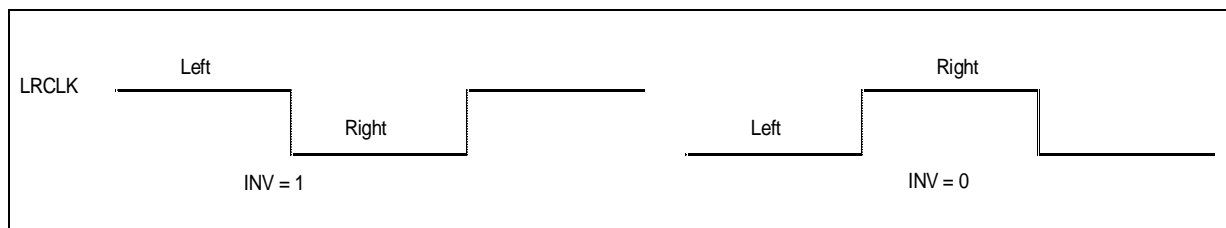

Figure 17. LRCLK Polarity



6 S/PDIF OUTPUT

The S/PDIF output pad is a TTL output pad with slew rate control. The output DC capability is 4 mA. The voltage drop is 3V. This output must be connected to a TTL driver before the transformer.

The S/PDIF output supports SPDIF and IEC-61937 standards. Several registers must be initialized to configure the SPDIF output:

- The category code must be entered in the IEC958_CAT register. It is related to the type of application. The category code is specified in the Digital Output Interface standard.
- The status bits that will be transmitted on the SPDIF output, must be programmed in the IEC958_STATUS register.
- IEC clock setting must be specified in the IEC958_CONF register.
- The data type dependent information can be specified in the IEC958_DTDI register.
- The S/PDIF type is selected through the IEC958_CMD register: the IEC unit can output decoded data (PCM mode), encoded data, or null data.

Note: 1. The SPDIF output handles only 48kHz or 44.1kHz sample rates.

6.1 SPDIF output

When configured in SPDIF mode, the S/PDIF output is used to transmit either the L/R channels (PCMOUT1) or VCR_L/VCR_R (PCMOUT0).

The selection is done by choosing the PCM mode and AUX = 1 in the register SPDIF_CMD and resetting the COM status of SPDIF_STATUS register.

6.2 IEC-61937 output

When configured in IEC-61937 mode, the S/PDIF output is used to transmit encoded data taken directly from the frame buffer.

The selection is done by choosing the encoded mode (ENC mode) in the register IEC958_CMD and setting the bit COM in IEC958_STATUS register.

The decompressed data are output simultaneously on the PCM_OUT outputs.

Latency in software versions 6 and later

For software versions 6 and later, when choosing to output encoded S/PDIF data, a latency is automatically inserted between S/PDIF output and PCM outputs. The PCM outputs are delayed compared to the SPDIF output.

The latency value is defined by standards and applied when the auto-latency mode is selected.

AC3 decoding

$$\begin{aligned} \text{Latency} &= 1/F_s * (1/3 * \text{Framesize} + 256) \\ &= 1/F_s * (32 * \text{Datarate}/F_s + 256) \end{aligned}$$

MPEG decoding

$$\text{Latency} = 1/F_s * (36 * \text{Datarate}/F_s + 96)$$

where F_s is the sampling frequency in kHz, Framesize is expressed in 16-bit words, Datarate is the bit rate in kbits per second.

The latency insertion can not be disabled however it can be programmed to values different from those required in the standard by selecting the user-programmable-latency mode (by setting the bit 7 of IEC858_CONF regis-

ter). In this case, the latency is specified in the IEC958_LATENCY register.

Note that there are minimum and maximum values to respect

Table 7.

AC-3		MPEG	
Min. Latency	Max. Latency	Min. Latency	Max. Latency
256 samples / Fs	1536 samples / Fs	96 samples / Fs	1152 samples / Fs

If those limits are not respected, an error interrupt occurs corresponding to error type: LATENCY_TOO_BIG, which automatically makes the chip switch to auto_latency mode.

For software versions prior to 6, the latency is not implemented.

6.3 PCM null data

When configured in muted mode (in the IEC958_CMD register), the outputs are PCM null data. This can be used to synchronize the external IEC receiver.

7 INTERRUPTS

7.1 Interrupt register

The decoder can signal to the external controller that an interrupt has occurred during the execution. The register INTE enables to select which interrupts will be generated and output on the \overline{IRQ} output pin.

When an interrupt occurs, the signal \overline{IRQ} is activated low and the controller can check which interrupt was detected by reading the register INT.

According to the type of interrupt detected, other information can be obtained by reading associated registers (such as stream header, type of error detected, PTS value).

7.2 \overline{IRQ} Signal

This signal, \overline{IRQ} , is a three-state line. This signal indicates (by going low) when an interrupt occurs. It returns to high level once the corresponding bit in the interrupt register has been cleared.

7.3 Error concealment

Errors are signaled as interrupts by the audio core. The error list is provided in. Most of the errors are automatically handled by the core, some require that software be changed.

AC-3 decoding errors:

Those errors are signaled in the ERROR register but handled directly by the core. Nothing can be done by the software. They signal that something wrong happened during the decoding. The core soft mutes the frame and continues to decode.

MPEG decoding errors:

Those errors are also signaled in the ERROR register but handled directly by the core. Nothing can be done by the software. They signal that something wrong happened during the decoding. The core soft mutes the frame and continues to decode. Only one error in this category indicates a programming error: if triggering the



MPEG_EXT_CRC_ERROR, the bit MC_OFF must be set. This indicates that the decoder tries to decode more than 2 channels whereas the incoming stream contains only 2 channels.

Packet and audio synchronization errors:

Those errors are handled internally, and usually indicate that the incoming bitstream is incorrect or incorrectly input to the chip. In those cases, the decoder resets the corresponding parsing stage (packet or audio parser) then searches for the next correct frame.

Miscellaneous errors:

- LATENCY_TOO_BIG error indicates a problem of latency programming which is superior to the maximum authorized value.

Change the latency value or switch to auto-latency mode to solve the problem. Other miscellaneous errors are internally handled.

8 AUDIO/VIDEO SYNCHRONIZATION

8.1 Presentation time stamp detection

8.1.0.1 $\overline{\text{PTS}}$ Signal

This signal, $\overline{\text{PTS}}$, is used to signal the detection of a Presentation Time Stamp in a stream, for audio/video synchronization. When a PTS is detected, the signal $\overline{\text{PTS}}$ goes low during one LRCLK period. It is generated while the PCM are output, so to enable the use of an external counter to synchronize the STA310 with a video decoder.

The signal is activated, even if PTS interrupt is not enabled.

8.1.1 PTS interrupt

When enabled through the INTE register, the interrupt $\overline{\text{PTS}}$ is generated when a PTS is detected. The interrupt is signalled on the $\overline{\text{IRQ}}$ output, which goes low. The $\overline{\text{IRQ}}$ signal is de-activated once the PTS bit has been cleared in INT register by reading the PTS Most Significant Bit.

8.1.2 PTS interrupt and signal relative timings

The $\overline{\text{IRQ}}$ configured as PTS interrupt is output before the $\overline{\text{PTS}}$ signal. The $\overline{\text{PTS}}$ signal is activated at last one period of LRCLK after the $\overline{\text{IRQ}}$ signal.

8.2 Frames skip capability

When the audio decoder is late compared to the video decoder, the decoder is able to skip frames. Writing 1 in the SKIP_FRAME register makes the decoder ignore the next incoming frame. Once skipping the frame, it continues to decode the stream, and the SKIP_FRAME register is automatically reset.

8.3 Frames repeat capability

When the audio decoder is ahead of the video decoder, the decoder can repeat frames. Writing 1 in the REPEAT_FRAME register makes the decoder repeat the current frame. Once repeating the frame, the chip plays the next incoming frame, and the REPEAT_FRAME register is reset.

9 REGISTER MANUAL

9.1 Introduction

The STA310 device contains 256 registers.

Two types of registers exist:

- From address 0x00 to 0x3F, the registers are real registers that can be initialized after reset.
- From address 0x40 to 0x100, they are memory locations. This means that the registers located at the address 0x40 to 0x100 can have different meanings and usage according to the mode in which the device operates.

Be careful that they can not be hardware reset: they contain undefined values at reset and require to be initialized after each hardware reset.

In this document, only the user registers are described.

The undocumented registers are reserved. These registers must never be accessed (neither in Read nor in Write mode).

The Read only registers must never be written

9.2 Register map by function

Code	Description
(a)	Register modification is ALWAYS taken into account by the audio decoder. Any change to these registers is taken into account immediately.
(b)	Register modification is taken into account AFTER EVERY DECODED DATA BLOCK or JUST AFTER RESET (soft or hard). The decoded block is related to the granularity of the computation in the audio decoder software. A block is 256 samples in Dolby Digital, 96 samples in MPEG, 80 samples in LPCM/PCM.
(f)	Register modification is taken into account AFTER EVERY DATA FRAME. A frame is: 1152 samples in MPEG I/II, 1536 samples in Dolby Digital, 384 samples in MPEG-1 layer 1, 80 samples in LPCM/PCM.
(r)	Register modification is taken into account ONLY WHEN THE DSP IS RUN AFTER RESET (soft or hard).
(1)	The delay registers are updated when bit 0 of the UPDATE register is set to 1.
(2)	The volume is updated when CHAN_IDX is set to the appropriate value.
(3)	The Karaoke mode is updated when KAR_UPDATE is set to '1'.

The following tables list the register map by address and function, then each audio decoder register is described individually

Table 8.

Register function	HEX	DEC	Name
VERSION	0x00	0	VERSION
	0x01	1	IDENT
	0x71	113	SOFT'VER
SETUP + INPUTS	0x0C	12	SIN_SETUP (a)
	0x0D	13	CAN_SETUP (a)
PCM CONFIGURATION	0x54	84	PCMDIVIDER (b)
	0x55	85	PCMCONF (b)
	0x56	86	PCMCROSS (b)
DAC AND PLL CONFIGURATION	0x05	5	SFREQ (f)
	0x12	18	PLLCTRL (f)
	0x18	24	PLLMASK (a)
	0x0E	14	DATA IN
	0x12	18	PLLCTRL (f)
	0x11	17	PLL_DATA (a)
	0x1D	29	PLL_CMD(f)
	0x12	18	PLL_ADD (f)
	0xB5	181	ENA_ALL FRACPLL
	0xB6	182	AU_PLL_FRACL_192
	0xB7	183	AU_PLL_FRACH_192
	0xB8	184	AU_PLL_XDIV_192
	0xB9	185	AU_PLL_MDIV_192
	0xBA	186	AU_PLL_NDIV_192
	0xBB	187	AU_PLL_FRACL_176
	0xBC	188	AU_PLL_FRACH_176
	0xBD	189	AU_PLL_XDIV_176
0xBE	190	AU_PLL_MDIV_176	

Register function	HEX	DEC	Name
CHANNEL DELAY SETUP	0x57	87	LDLY (1)
	0x58	88	RDLY (1)
	0x59	89	CDLY (1)
	0x5A	90	SUBDLY (1)
	0x5B	91	LSDLY (1)
	0x5C	92	RSDLY (1)
	0x5D	93	UPDATE (f)
	0xAF	91	LVDLY (1)
	0xB0	92	RVDLY (1)
SPDIF OUTPUT SETUP	0x5E	94	SPDIF_CMD (r)
	0x5F	95	SPDIF_CAT (f)
	0x60	96	SPDIF_CONF (b)
	0x61	97	SPDIF_STATUS (b)
	0x75	117	SPDIF_REP_TIME (b)
	0x7E	126	SPDIF_LATENCY (f)
	0x7F	127	SPDIF_DTDI (f)
COMMAND	0x10	16	SOFTRESET (a)
	0x13	19	PLAY (a)
	0x14	20	MUTE (a)
	0x72	114	RUN (a)
	0x73	115	SKIP_MUTE_CMD (f)
	0x74	116	SKIP_MUTE_VALUE(f)
INTERRUPT	0x07, 08	7, 8	INTE (a)
	0x09, 0A	9, 10	INT (a)
INTERRUPT STATUS	0x40	64	SYNC_STATUS
	0x41	65	ANCCOUNT
	0x42	66	HEAD4 (f)
	0x43	67	HEAD3 (f)
	0x44, 45	68, 69	HEADLEN (f)
	0x46 - 4A	70	PTS (f)
	0x0F	15	ERROR
DECODING ALGORITHM	0x4C	76	STREAMSEL (r)
	0x4D	77	DECODSEL (r)
SYSTEM SYNCHRONIZATION	0x4F	79	PACKET_LOCK (r)
	0x50	80	ID_EN (a)
	0x51	81	ID (a)
	0x52	82	ID_EXT (a)
	0x53	83	SYNC_LOCK (r)
POST DECODING AND PRO LOGIC	0x62	98	PDEC1 (b)
	0xB1	177	PDEC2
	0x64	100	PL_AB (b)
	0x65	101	PL_DWNX (b)
	0x66	102	OCFG
	0x70	112	DWSMODE (b)

Register function	HEX	DEC	Name
BASS REDIRECTION	0x4E	78	VOLUME0 (2)
	0x63	100	VOLUME1 (2)
	0x66	102	OCFG (b)
	0x67	103	CHAN_IDX (b)
DOLBY DIGITAL CONFIGURATION	0x68	104	AC3_DECODE_LFE (b)
	0x69	105	AC3_COMP_MOD (b)
	0x6A	106	AC3_HDR (b)
	0x6B	107	AC3_LDR (b)
	0x6C	108	AC3_RPC (b)
	0x6D	109	AC3_KARAMODE (b)
	0x6E	110	AC3_DUALMODE (b)
	0x6F	111	AC3_DOWNMIX (b)
	0x76	118	AC3_STATUS0 (f)
	0x77	119	AC3_STATUS1 (f)
	0x78	120	AC3_STATUS2 (f)
	0x79	121	AC3_STATUS3 (f)
	0x7A	122	AC3_STATUS4 (f)
	0x7B	123	AC3_STATUS5 (f)
	0x7C	124	AC3_STATUS6 (f)
	0x7D	125	AC3_STATUS7 (f)
MPEG CONFIGURATION	0x68	104	MP_SKIP_LFE (b)
	0x69	105	MP_PROG_NUMBER (b)
	0x6E	106	MP_DUALMODE (b)
	0x6A	110	MP_DRC (b)
	0x6C	108	MP_CRC_OFF (b)
	0x6D	109	MP_MC_OFF (b)
	0x6F	111	MP_DOWNMIX (b)
	0x76	118	MP_STATUS0 (f)
	0x77	119	MP_STATUS1 (f)
	0x78	120	MP_STATUS2 (f)
	0x79	121	MP_STATUS3 (f)
	0x7A	122	MP_STATUS4 (f)
	0x7B	123	MP_STATUS5 (f)
PINK NOISE GENERATION REGISTERS	0x6F	111	PN_DOWNMIX
PCM BEEP-TONE CONFIGURATION	0x68	104	PCM_BTONE (b)

Register function	HEX	DEC	Name
KARAOKE	0x81	129	KAR_MCh0VOL (3)
	0x82	130	KAR_MCh1VOL (3)
	0x83	131	KAR_KEYCONT (3)
	0x84	132	KAR_KEYVALUE (3)
	0x85	133	KAR_VCANCEL (3)
	0x86	134	KAR_VVALUE (3)
	0x87	135	KAR_MMUTE (3)
	0x88	136	KAR_VCh0VOL (3)
	0x89	137	KAR_VCh1VOL (3)
	0x8A	138	KAR_DUET (3)
	0x8B	139	KAR_DUETTHRESH (3)
	0x8C	140	KAR_VOICE (3)
	0x8D	141	KAR_VDELAY (3)
	0x8E	142	KAR_VBAL (3)
	0x8F	143	KAR_VMUTE (3)
	0x90	144	KAR_PLAY (3)
	0x91	145	KAR_MODE (3)
	0x92	146	KAR_DIN_CTL (3)
0x93	147	KAR_UPDATE	
SECOND SERIAL INPUT	0x94	148	SFREQ2
	0x95	149	CANINPUT_MODE
LINEAR PCM (DVD AUDIO) REGISTERS	0x6F	111	LPCMA_DOWNMIX
	0x70	112	LPCMA_FORCE_DWS
	0x76	118	LPCMA_STATUS0
	0x77	119	LPCMA_STATUS1
	0x78	120	LPCMA_STATUS2
	0x79	121	LPCMA_STATUS3
	0x7A	122	LPCMA_STATUS4
	0x7B	123	LPCMA_STATUS5
	0x97	151	LPCMA_DM_COEFT_0
	0x98	152	LPCMA_DM_COEFT_1
	0x99	153	LPCMA_DM_COEFT_2
	0x9A	154	LPCMA_DM_COEFT_3
	0x9B	155	LPCMA_DM_COEFT_4
	0x9C	156	LPCMA_DM_COEFT_5
	0x9D	157	LPCMA_DM_COEFT_6
	0x9E	158	LPCMA_DM_COEFT_7
	0x9F	159	LPCMA_DM_COEFT_8
	0xA0	160	LPCMA_DM_COEFT_9
0xA1	161	LPCMA_DM_COEFT_10	
0xA2	162	LPCMA_DM_COEFT_11	
0xA3	163	LPCMA_DM_COEFT_12	
0xA4	164	LPCMA_DM_COEFT_13	
LINEAR PCM (DVD VID & PCM) REGISTERS	0x6F	111	LPCMV_DOWNMIX

Register function	HEX	DEC	Name
	0x70	112	LPCMV_FORCE_DWS
	0x76	118	LPCMV_STATUS0
	0x77	119	LPCMV_STATUS1
	0x78	120	LPCMV_STATUS2
	0x97	151	LPCMV_DM_COEFT_0
	0x98	152	LPCMV_DM_COEFT_1
	0x99	153	LPCMV_DM_COEFT_2
	0x9A	154	LPCMV_DM_COEFT_3
	0x9B	155	LPCMV_DM_COEFT_4
	0x9C	156	LPCMV_DM_COEFT_5
	0x9D	157	LPCMV_DM_COEFT_6
	0x9E	158	LPCMV_DM_COEFT_7
	0x9F	159	LPCMV_DM_COEFT_8
	0xA0	160	LPCMV_DM_COEFT_9
	0xA1	161	LPCMV_DM_COEFT_10
	0xA2	162	LPCMV_DM_COEFT_11
	0xA3	163	LPCMV_DM_COEFT_12
	0xA4	164	LPCMV_DM_COEFT_13
	0xA8	168	LPCMV_CH_ASSIGN
	0xA9	169	LPCMV_MULTI_CHS
DE-EMPHASIS REGISTER	0xB5	181	DEEMPH
AUXILLIARY OUTPUTS REGISTERS	0xAE	174	VCR_MIX
	0xAF	175	VCR_LDLY
	0xB0	176	VCR_RDLY
MISCELLANEOUS	0x2B	43	BREAKPOINT
	0x3A	58	CLOCKCMD
	0xFF	255	INIT_RAM
SPDIF AUTODETECTION	0xE0	224	AUTODETECT_ENA
	0xE1	225	AUTODETECT_SENS
	0xE2	226	AUTODETECT_ALIGN

9.3 VERSION REGISTERS**IDENT****Identify**

7	6	5	4	3	2	1	0
1	0	1	0	1	1	0	0

Address: 0x01

Type: RO

Software Reset: 0x31

Hardware Reset: 0x31

Description:

IDENT is a read-only register and is used to identify the IC on an application board. IDENT always has the value "0x31".

SOFTVER**Software version**

7	6	5	4	3	2	1	0

Address: 0x71

Type: R/W

Software Reset: NC

Hardware Reset: UND

Description:

This SOFTVER register is the version of the code which is running on the device. This register is updated by the embedded software just after a soft reset of the device:

- For STA310 cut 1.0 the register contain the value 0x0A
- For STA310 cut 2.0 the register contain the value 0x14

Loading a patch into the STA310 will automatically change the register content.

Please contact ST to have the correct value according to the patch being used.

This register must be readonly after the STA310 has finished booting, in order to get a correct value (when INIT_RAM register hold the value 1)

VERSION**Version**

7	6	5	4	3	2	1	0
0	0	0	1	0	0	0	0

Address: 0x00

Type: RO

Software Reset: NA
 Hardware Reset: NA

Description:

This version register is read only and is used to identify the audio hardware version. The version register holds a number which refers to the cut number. The version numbers are defined as below:

- STA310 cut 1.0, version number is : 0x10
- STA310 cut 2.0, version number is : 0x10

9.4 SETUP & INPUT REGISTERS

The STA310 can get receive an input bitstream either from the I2s input or ffrom the Spdif input, the selection and the configuration is done through 2 registers SIN_SETUP @ 12 and CAN_SETUP @ 13.

SIN SETUP

Input data setup

7	6	5	4	3	2	1	0
				SPDIF	POL	IMODE [1...0]	

Address: 0x0C

Type: R/W

Software Reset: NC

Hardware Reset: 0

Description:

This register is used to configure the input data interface. The register must be setup before sending data to the IC. The mapping of the register is described below. Remember that the data must be sent to the device MSB first.

- **SPDIF** data frpm SPDIF when set to 1, data from main I²S input.
- **POL** Polarity of the REQ signal. When set, the REQ pin is active low: data must be input when REQ is low. When reset, the REQ pin is active high and data must be input when REQ is high.
- **IMODE[1...0]** Input mode. Indicates which data input interface is used.

The configuration of the 3 possible interfaces is

shown below:

IMODE[1:0]	Mode
0	Parallel input (DSTR+Data [7:0] + REQ)
1	Serial input (DSTR + SIN + REQ)
2	Reserved - Not used
3	A/D input (DSTR+LRCLKIN+REQ+SIN; SPDIF input; PCM input)

When the IC is configured in mode 1 or 3, the CAN_SETUP register is used to configure the IC with respect to the data format.

CAN_SETUP

A/D converter setup

7	6	5	4	3	2	1	0
				S16	SAM	FIR	PAD

Address : 0x0D

Type: R/W

Software Reset: NC

Hardware Reset: 0

Description:

CAN_SETUP is used to configure the data serial interface. The register is only taken into account when the register sin_setup [1...0] = 3.

Also see SIN_SETUP register./

- **S16** When set, the slot count is 16. When reset, the slot count is 32 but only the first 16 are extracted.
- **SAM** When set data is sampled on the falling edge of the DSTR. When reset, the data is sampled on the rising edge of DSTR
- **FIR** When set the first channel (Left) is input when Lrclk=1. When reset, the first channel is input when Lrclk=0.
- **PAD** When set, data Lrclk is delayed by one cycle (padding mode).

When the IC is configured with the S/SPDIF input, register CAN_SETUP must be set to 2

DATAIN

Data input

7	6	5	4	3	2	1	0



STA310

Address : 0x0E

Type: WO

Software Reset: NA

Hardware Reset: NA

Description:

Data can be fed into the STa310 by using this register instead of the dedicated interface. there is no need to byte align the bitstream when using this register.

9.5 PCM CONFIGURATION RESISTERS

PCMDIVIDER

Divider for PCM clock

7	6	5	4	3	2	1	0

Address : 0x54

Type: R/W

Software Reset: UND

Hardware Reset: UND

Description:

The PCM divider must be set according to the formula below, where DAC_SCLK is the bit clock for the DAC. When Div is set to 0, DAC_SCLK is equal to DAC_PCMCLK:

$$\text{Div} = (\text{DAC_PCMCLK} / (2 \times \text{DAC_SCLK})) - 1$$

When the internal PLL is used, DAC_PCMCLK=384 x fs or 256 x fs. If DAC_PCMCLK = 384 x fs, the formula becomes:

$$\text{Div} = (192 \times \text{Fs} / \text{DAC_SCLK}) - 1$$

If DAC_SCLK is 32 x Fs (common case with the 16 bit DAC), Div must be set to 5.

PCM divider value	Mode description
5	DAC_PCMCLK = 384Fs, DAC is 16-bit mode
3	DAC_PCMLK = 256 Fs, DAC is 16-bit mode

PCM divider value	Mode description
2	DAC_PCMLK = 384 Fs, DAC is 32-bit mode
1	DAC_PCMLK = 256 Fs, DAC is 32-bit mode

PCMCONF

PCM configuration

7	6	5	4	3	2	1	0
	ODR	DIF	INV	FOR	SCL	PREC[1:0]	

Address: 0x55

Type: R/W

Software Reset: NC

Hardware Reset: UND

Description:

Bitfield	Description
ORD	PCM Order: This bit is significant only when in 16-bit mode. When set, LSB is sent first. When reset, MSB is sent first.
DIF	PCM_DIFF: This bit is not significant in 16-bit. When set, indicates that the bits are not right-padded in the slot. When reset, it is right padded.
INV	INV_LRCLK: When set the polarity of LRCLK is inverted: Left channel is output when LRCLK is high. When reset, the polarity of LRCLK is such that the left channel is output when LRCLK is low.
FOR	FORMAT: This bit selects the data output format: When set, the Sony format is chosen. When reset 0 the format is IS format.
SCL	INV_SCLK: When set, the polarity of SCLK is inverted, the PCM outputs and LRCLK will be stable for the DACs on the falling edge of SCLK. When reset, PCM outputs and LRCLK are stable on the rising edge of SCLK.
PREC[1:0]	PCM Precision 0: 16 bit mode (16 slots) 1: 18 bit mode (32 slots) 2: 20 bit mode (32 slots) 3: 24 bit mode (32 slots)

PCM CROSS

7	6	5	4	3	2	1	0
VCR		CLR[1:0]		CSW[1:0]		LRS[1:0]	

Address: 0x56

Type: R/W

Software Reset: NC

Hardware Reset: UND

Description:

The PCMCROSS register only acts if bit PFC of register SPDIF_DTDI is set.

Bitfield	Description
LRS[1:0]	Cross left and right surround.
CSW[1:0]	Cross centre and subwoofer.
CLR[1:0]	Cross left and right channels. 00 : Left channel is mapped on the left output, Right channel is mapped on the Right output. 01 : Left channel is duplicated on both outputs. 10 : Right channel is duplicated on both outputs. 11 : Right channel and Left channel are toggled.
VCR[1:0]	These 2 bits manage the VCR outputs.

Fs (KHz)	46	44.1	32	-	96	88.2	64	-	24	22.05
Value	0	1	2	3	4	5	6	7	8	9

Fs (KHz)	16	-	12	11.025	8	-	192	176.4	128	-
Value	10	11	12	13	14	15	16	17	18	19

PLLCTRL

PLL Control

7	6	5	4	3	2	1	0
			SYSCLSCK[1..0]		OCLK[2..0]		

Address: 0x12

Type: R/W

Software Reset: NA

Hardware Reset: 0x19

Description:

Bitfield	Value	Description	
OCLK [2:0]		Configure PCMCLK source and direction	PCMCLK pad direction
	-01	Audio master Clock from PCMLCK pad.	Input
	011	Audio master Clock from internal audio PLL	Input
	111	Audio master Clock from internal S/PDIF receiver	Input
	-00	Forbidden	
	010	Audio master Clock from internal audio PLL	Output
SYSCLC K[1:0]	110	Audio master Clock from internal S/PDIF receiver	Output
	0	System Clock from CLK pad Output	
	1	System Clock from CLK pad divided by 2	
	2	System Clock from internal system PLL	
	3	System Clock from internal system PLL divided by 2	

9.6 PDAC and PLL configuration registers

SFREQ

Sampling frequency

7	6	5	4	3	2	1	0

Address: 0x05

Type: R/WS

Software Reset: NC

Hardware Reset: 0

Description:

This status register holds the code of the current sampling frequency. If the audio stream is encoded (Dolby Digital, MPEG) or packetized (DVD_LPCM), the sampling frequency is automatically read in the audio stream and written into this register by the audio DSP. The register is automatically updated by the DSP when it performs a down-sampling (for example, 96kHz to 48kHz).

The DSP resets SFREQ to 0.

For PCM stream or CDDA, this register is written to by the application. The value in SFREQ corresponds to the following frequencies:.

PLL_DATA



PLLDATA

7	6	5	4	3	2	1	0

Address: 0x11

Type: R/W

Software Reset: NA

Hardware Reset: 0

Description:

Data that must be written (has been read) at (from) the address specified by PLL_ADD.

PLL_CMD

PLL Command

7	6	5	4	3	2	1	0
				AUPLLCTL	SYSPLLCTL	RWCTL[1:0]	

Address: 0x1D

Type: R/W

Software Reset: NA

Hardware Reset: 0

Description:

Bitfield	Description
RWCTL [1:0]	Configure PCMCLK source and direction. 00: No action is performed on the configuration registers of the level 1 01: Read action of the configuration registers. During this phase, the content of a selectable (by PLL_ADD) register of the level 1 is copied into the PLL_DATA register. 10: Write action of the configuration registers. During this phase, the content of a selectable (by PLL_ADD) register of the level 1 is copied into the PLL_DATA register. 11: Forbidden
SYSPLLCTL	System PLL coefficients transfert 0: No Transfer 1: Transfer the data between the level 1 and the level 2 for the system PLL
AUPLLCTL	Audio PLL coefficient transfert 0: No Transfer 1: Transfer the data between the level 1 and the level 2 for the audio PLL

PLL_ADD

PLL Address

7	6	5	4	3	2	1	0
ADDRESS							

Address: 0x12

Type: R/W

Software Reset: NA

Hardware Reset: 0

Description:

Value	Address of PLLs configuration registers
Address	2: Disable System PLL 3: System PLL frac Low 4: System PLL frac High 6: System PLL N divider 7: System PLL X divider 8: System PLL M divider 9: System PLL update 10: Disable Audio PLL 11: Audio PLL frac Low 12: Audio PLL frac High 14: Audio PLL N divider 15: Audio PLL X divider 16: Audio PLL M divider 17: Audio PLL update

ENA_AU_FRACPLL

Audio PLL Enable

7	6	5	4	3	2	1	0
							ENA_PLL

Address: 0xB5

Type: R/W

Software Reset: 1

Hardware Reset: 0

Description:

This register is used to enable the audio PLL of the STA310. This register must be always set to "1" after either a soft or hardware reset.

AU_PLL_FRACL_192

Frac Low Coefficient

7	6	5	4	3	2	1	0
FRACL							

Address: 0xB6

Type: R/W

Software Reset: 0x34

Hardware Reset: UND

Description:

This register must contain a FRACL value that enables the audio PLL to generate a frequency of ofact*192KHz for the PCMCK.

Default value at soft reset assume:

- Oversampling factor (ofact) = 384. PCMLCK = 384 x SF (where SF is the sampling frequency)
- External crystal provide a clock running at 27MHz

AU_PLL_FRACH_192

Frac High Coefficient

7	6	5	4	3	2	1	0
FRACH							

Address: 0xB7

Type: R/W

Software Reset: 0xEC

Hardware Reset: UND

Description:

This register must contain a FRACH value that enables the audio PLL to generate a frequency of ofact*192KHz for the PCMCK.

Default value at soft reset assume:

- Oversampling factor (ofact) = 384. PCMLCK = 384 x SF (where SF is the sampling frequency)
- External crystal provide a clock running at 27MHz

AU_PLL_XDIV_192

X Divider Coefficient

7	6	5	4	3	2	1	0
XDIV							

Address: 0xB8

Type: R/W

Software Reset: 0x01

Hardware Reset: UND

Description:

This register must contain a XDIV value that enables the audio PLL to generate a frequency of ofact*192KHz for the PCMCK.

Default value at soft reset assume:

- Oversampling factor (ofact) = 384. PCMLCK = 384 x SF (where SF is the sampling frequency)
- External crystal provide a clock running at 27MHz

AU_PLL_MDIV_192

M Divider Coefficient

7	6	5	4	3	2	1	0
MDIV							

Address: 0xB9

Type: R/W

Software Reset: 0x09

Hardware Reset: UND

Description:

This register must contain a MDIV value that enables the audio PLL to generate a frequency of ofact*192KHz for the PCMCK.

Default value at soft reset assume:

- Oversampling factor (ofact) = 384. PCMLCK = 384 x SF (where SF is the sampling frequency)
- External crystal provide a clock running at 27MHz

AU_PLL_NDIV_192

N Divider Coefficient

7	6	5	4	3	2	1	0
NDIV							

Address: 0xBA

Type: R/W

Software Reset: 0x01

Hardware Reset: UND

Description:

This register must contain a NDIV value that enables the audio PLL to generate a frequency of ofact*192KHz for the PCMCK.

Default value at soft reset assume:

- Oversampling factor (ofact) = 384. PCMLCK =



- 384 x SF (where SF is the sampling frequency)
- External crystal provide a clock running at 27MHz

AU_PLL_FRACL_176

Frac Low Coefficient

7	6	5	4	3	2	1	0
FRACL							

Address: 0xBB
 Type: R/W
 Software Reset: 0x3
 Hardware Reset: UND

Description:
 This register must contain a FRACL value that enables the audio PLL to generate a frequency of ofact*176KHz for the PCMCK.

Default value at soft reset assume:
 – Oversampling factor (ofact) = 384. PCMLCK = 384 x SF (where SF is the sampling frequency)
 – External crystal provide a clock running at 27MHz

AU_PLL_FRACH_176

Frac High Coefficient

7	6	5	4	3	2	1	0
FRACH							

Address: 0xBC
 Type: R/W
 Software Reset: 0x9
 Hardware Reset: UND

Description:
 This register must contain a FRACH value that enables the audio PLL to generate a frequency of ofact*176KHz for the PCMCK.

Default value at soft reset assume:
 – Oversampling factor (ofact) = 384. PCMLCK = 384 x SF (where SF is the sampling frequency)
 – External crystal provide a clock running at 27MHz

AU_PLL_XDIV_176

X Divider Coefficient

7	6	5	4	3	2	1	0
XDIV							

Address: 0xBD
 Type: R/W
 Software Reset: 0x01
 Hardware Reset: UND

Description:
 This register must contain a XDIV value that enables the audio PLL to generate a frequency of ofact*176KHz for the PCMCK.

Default value at soft reset assume:
 – Oversampling factor (ofact) = 384. PCMLCK = 384 x SF (where SF is the sampling frequency)
 – External crystal provide a clock running at 27MHz

AU_PLL_MDIV_176

M Divider Coefficient

7	6	5	4	3	2	1	0
MDIV							

Address: 0xBE
 Type: R/W
 Software Reset: 0x09
 Hardware Reset: UND

Description:
 This register must contain a MDIV value that enables the audio PLL to generate a frequency of ofact*176KHz for the PCMCK.

Default value at soft reset assume:
 – Oversampling factor (ofact) = 384. PCMLCK = 384 x SF (where SF is the sampling frequency)
 – External crystal provide a clock running at 27MHz

AU_PLL_NDIV_176

N Divider Coefficient

7	6	5	4	3	2	1	0
NDIV							



Address: 0xBF
 Type: R/W
 Software Reset: 0x01
 Hardware Reset: UND

Description:
 This register must contain a NDIV value that enables the audio PLL to generate a frequency of ofact*176KHz for the PCMCK.
 Default value at soft reset assume:
 – Oversampling factor (ofact) = 384. PCMLCK = 384 x SF (where SF is the sampling frequency)
 – External crystal provide a clock running at 27MHz

INIT_RAM
STa310 boot Done

7	6	5	4	3	2	1	0
							RAM_INIT

Address: 0xFF
 Type: RO
 Software Reset: 1
 Hardware Reset: 0

Description:
 This register is used to signal when the STA310 has finished to boot. After a soft reset or a hardware reset, the host processor must wait until INIT_RAM hold the value "1".
 The host can then start to configure the STA310 according to its application.

PLLMASK
PCMCLK mask for half sampling frequency

7	6	5	4	3	2	1	0
							HALF_FS

Address: 0x18
 Type: W
 Software Reset: NC

Hardware Reset: 0

Bitfield	Description
HALF_FS	If the incoming bitstream is encoded with half sampling frequency, the device generates a PCM clock (for audio DAC) 1: At 256 x half_fs or 384 x half_fs (half_fs is equal to 24KHz, 22.05KHz, 16KHz). 0: At 256 x fs or 384 x fs (fs is equal to 48KHz, 44.1KHz, 32KHz). This function is mainly use for DAC frequency adaptation.

9.7 Channel delay set-up registers

The six delay setup registers are used to set the relative delays to the (up to) six loud speaker channels in order to give the sound effects of, for example, a large room or to compensate for the listener not being in the centre of the loud speaker system. The sum of the delays on the channels must be less than or equal to 35ms.

The unit for the register delay contents is a group of 16 samples.

Each register value is chosen using the expression: desired channel delay**sampling frequency'/16 samples and taking care to ensure that the sum of the 'desired channel delays' is not more than 35ms.

For example, when the sampling frequency is 48kHz, the sum of the values programmed in the six delay registers must be less than or equal to:

$$35 \text{ ms} * 48 \text{ KHz} / 16 \text{ samples} = 105.$$

When only one surround channel is present (in Pro Logic or other mode), the right surround delay must be cleared, and the left delay channel is used for both surround channels.

LDLY
Left channel delay

7	6	5	4	3	2	1	0

Address: 0x57
 Type: R/W
 Software Reset: NC
 Hardware Reset: UND



Delay on left channel, expressed in number of group of 16 samples. LDLY = delay (ms) * Fs (kHz) / 16

RDLY

Right channel delay

7	6	5	4	3	2	1	0

Address: 0x58

Type: R/W

Software Reset: NC

Hardware Reset:UND

Delay on right channel, expressed in number of group of 16 samples. RDLY = delay (ms)*Fs (kHz)/16

CDLY

Centre channel delay

7	6	5	4	3	2	1	0

Address: 0x59

Type: R/W

Software Reset: NC

Hardware Reset: UND

Description:

Delay on center channel, expressed in number of group of 16 samples. CDLY = delay (ms) * Fs (kHz) / 16

SUBDLY

Subwoofer channel delay

7	6	5	4	3	2	1	0

Address: 0x5A

Type: R/W

Software Reset: NC

Hardware Reset: UND

Description:

Delay on subwoofer channel, expressed in number of group of 16 samples. SUBDLY = delay (ms) * Fs (kHz) / 16

LSDLY

Left surround channel delay

7	6	5	4	3	2	1	0

Address: 0x5B

Type: R/W

Software Reset: NC

Hardware Reset: UND

Delay on left surround channel, expressed in number of group of 16 samples. LSDLY = delay (ms) * Fs (kHz) / 16

RSDLY

Right surround channel delay

7	6	5	4	3	2	1	0

Address: 0x5C

Type: R/W

Software Reset: NC

Hardware Reset: UND

Description:

Delay on right surround channel, expressed in number of group of 16 samples. RSDLY = delay (ms) * Fs (kHz) / 16.

When only one surround channel is used, this register must be reset at initialization.

LVDLY

Left VCR channel delay

7	6	5	4	3	2	1	0

Address: 0xAF

Type: R/W

Software Reset: NC

Hardware Reset: UND

Description:

Delay on left VCR channel, expressed in number of group of 16 samples.

LSDLY = delay (ms) * Fs (kHz) / 16

RVDLY

Right VCR channel delay

7	6	5	4	3	2	1	0

Address: 0xB0

Type: R/W

Software Reset: NC

Hardware Reset: UND

Description:

Delay on right VCR channel, expressed in number of group of 16 samples. $RSDLY = \text{delay (ms)} * F_s \text{ (kHz)} / 16$.

When only one VCR channel is used, this register must be reset at initialization.

Software Reset: 0

Hardware Reset 0

Description:

Bitfield	Description
DLY	This bit must be set to 1 to force the DSP to update its delays values (read from the audio delay registers). 0: Delay values held in the audio delay registers are NOT updated in the DSP (i.e. the DSP will keep the delay values set previously) 1: The delay values held in the audio delay registers are updated in the DSP (i.e. the DSP will use the new values). This bit is automatically reset to zero after it the update has been carried out.
TM	Set to "0"

UPDATE

PCM delay update

7	6	5	4	3	2	1	0
						TM	DLY

Address: 0x5D

Type: R/W

9.8 SPDIF output set-up

SPDIF_CMD

SPDIF control

7	6	5	4	3	2	1	0
AUX	reserved				SPDIF_MODE[1:0]		

Address: 0x5E

Type: R/W

Software Reset: NC

Hardware Reset: UND

This register controls the SPDIF mode:

Description:

Bitfield	Description
SPDIF_MODE[1:0] AUX = '0'	00: OFF, the IEC60958 is not working and the output line is idle, 01: MUTE, the outputs are PCM null data, 10: PCM, the outputs are PCM data and only the Left/Right channels are transmitted, 11: EMC, in this "encoded" mode the compressed bitstream is transmitted in IEC61937 standard.
SPDIF_MODE[1:0] AUX = '1'	10: PCM, the outputs are PCM data and only the "VCR" channels are transmitted. All other values are reserved.

Category code

SPDIF_CAT

7	6	5	4	3	2	1	0
CATCODE							

STA310

Address: 0x5F

Type: R/W

Software Reset: NC

Hardware Reset: UND

Description:

The table below defines the category codes, values not listed are reserved.

Category code	Description
0 0 0 0 0 0 1 0 0 0 0 0 X X X 0 0 0 X X X 1 0 0	General Experimental Reserved Solid State Memory
0 0 0 0 1 0 1 1 0 0 1 0 0 0 0 1 1 0 1 0 0 0 1 0 X X X X 1 0	Broadcast reception of dig. audio Broadcast reception of dig. audio Broadcast reception of dig. audio Broadcast reception of dig. audio Broadcast reception of dig. audio
	Japan United states Europe Electronic Software delivery All other states are reserved
0 0 0 0 0 1 0 0 1 0 0 0 1 0 0 0 1 0 0 1 0 0 0 1 1 0 1 0 X X X X 0 1 0	Digital / Digital converters and signal processing Digital / Digital converters and signal processing Digital / Digital converters and signal processing Digital / Digital converters and signal processing Digital / Digital converters and signal processing
	PCM encoder/decoder Digital sound sampler Digital signal mixe Sample rate converter All other states are reserved
X X 0 0 1 1 0 X X 1 0 1 1 0 X X X 1 1 1 0	A/D converter W/o copyright A/D converter W/ copyright (using copy and L bits) Broadcast reception of dig. audio
0 0 0 0 0 0 1 0 0 0 1 0 0 1 X X X X 0 0 1	Laser optical CD - Compatible with IEC 908 Laser optical CD - Not compatible with IEC 908 (Magneto optical) Laser optical All other states are reserved
0 0 0 0 1 0 1 0 0 0 1 1 0 1 X X X X 1 0 1	Musical instruments, microphones, etc. Musical instruments, microphones, etc. Musical instruments, microphones, etc.
	Synthesizer Microphone All other states are reserved
0 0 0 0 0 1 1 0 0 0 1 0 1 1 X X X X 0 1 1	Magnetic tape or disks Magnetic tape or disks Magnetic tape or disks
	DAT Digital audio sound VCR All other states are reserved
X X X X 1 1 1	Reserved
7 0 1	Only cat. codes XXXX100, XXX1110, XXXX001 -> L bit Original, commercially pre-recorded data No indication of 1st generation or higher
7 0 1	All other categories No indication of 1st generation or higher Original, commercially pre-recorded data

SPDIF_CONF

SPDIF PCMCLK divider

7	6	5	4	3	2	1	0
LAT	SM=0	RND	DIV[4:0]				

Address: 0x60

Type: R/W

Software Reset:NC

Hardware: Reset:UND

Description:

Bitfield	Description
DIV[4:0]	This field is the DAC_PCMCLK divider. It must be set according to the formula: in 16 bit mode: $IECDIV=(1+PCMDIV)/2-1$; in 32 bit mode: $IECDIV=PCMDIV$
RND	This bit is used to have a "16-bit rounding" on the SPDIF (when in PCM mode): 0: no rounding, 1: rounding. This bit has no effect on the precision of analogue data
SM	SYNC MUTE Mode, must be set to zero.
LAT	Configures the latency mode between the SPDIF output (in mode compressed) and the Audio output. 0: Auto-Latency: The latency is the transmission time for 2/3 of the payload, plus the time to decode an audio block. For MPEG Auto-Latency, the latency is the following time depending of the sampling frequency in the incoming bitstream: MPEG 48KHz: 20.90ms, MPEG 44.1KHz: 22.95ms, MPEG 32KHz: 32.53ms. 1: User-programmable latency - the SPDIF_LATENCY register is used.

The table below shows the relationship between the value of the IEC divider and the value of the PCM divider.

PCM Divider Value	Mode Description	IEC Divider Value
5	DAC_PCMCLK = 384Fs, DAC is 16-bit mode	2
3	DAC_PCMCLK = 256 Fs, DAC is 16-bit mode	1
2	DAC_PCMCLK = 384 Fs, DAC is 32-bit mode	2
1	DAC_PCMCLK = 256 Fs, DAC is 32-bit mode	1

SPDIF_STATUS

SPDIF status bit

7	6	5	4	3	2	1	0
SFR					PRE	COP	COM

Address: 0x61

Type: R/W

Software Reset: NC

Hardware: Reset UND

Description:

STA310

This register is used to set the value of the status bit in the IEC958 data stream.

Bitfield	Description
COM	Compress data bit. 1: compressed mode 0: non compressed mode.
COP	1: copy allowed 0: copy not allowed
PRE	1: output has pre-emphasis 0: output does not have pre-emphasis
SFR	0000: if sampling frequency = 44.1KHz 0010: if sampling frequency = 48KHz 0011: if sampling frequency = 32KHz 1010: if sampling frequency = 96KHz

SPDIF_REP_TIME

SPDIF repetition time of a pause frame

7	6	5	4	3	2	1	0

Address: 0x75

Type: R/W

Software Reset: NC

Hardware: Reset: UND

Description:

In compressed mode, a burst of pause frames is sent when there are no more data to transmit (due to an error or a gap in the incoming bitstream, for example).

This register sets the size of a pause frame in IEC frames: Dolby Digital =4, MPEG=32 and DTS=3.

SPDIF_LATENCY

Latency value

7	6	5	4	3	2	1	0
Value							

Address: 0x7E

Type: R/W

Software Reset: NC

Hardware: Reset: UND

Description:

If bit LAT of register SPDIF_CONF is set, a delay can be configured between the output of IEC61937 in compressed mode and the output of the audio decoder. To configure a latency (in unit of seconds) this register has to be set according the following formula:

Value = L x FS/8 where, L=Latency in s and FS=Sampling frequency in Hz

The minimum latency delay is 0; the maximum latency delay is the time to decode a frame:

Bitfield	Description
Value	Dolby Digital: L = 1536 samples / Sampling frequency MPEG: L = 1152 samples / Sampling frequency

SPDIF_DTDI

SPDIF data-type information

7	6	5	4	3	2	1	0
PFC	DTD		INF				

Address: 0x7F

Type: R/W

Software Reset: NC

Hardware: Reset: UND

Description::

Bitfield	Description										
DTDI[4:0]	in Dolby Digital mode: <table border="1" style="display: inline-table; vertical-align: middle;"> <tr> <td>4</td> <td>3</td> <td>2</td> <td>1</td> <td>0</td> </tr> <tr> <td>0</td> <td>0</td> <td colspan="2">BSMOD [2..0]</td> <td></td> </tr> </table>	4	3	2	1	0	0	0	BSMOD [2..0]		
	4	3	2	1	0						
0	0	BSMOD [2..0]									
DTD	in MPEG mode: <table border="1" style="display: inline-table; vertical-align: middle;"> <tr> <td>4</td> <td>3</td> <td>2</td> <td>1</td> <td>0</td> </tr> <tr> <td>0</td> <td>0</td> <td>0</td> <td>DR</td> <td>K</td> </tr> </table>	4	3	2	1	0	0	0	0	DR	K
	4	3	2	1	0						
0	0	0	DR	K							
DTD	1: Data-type dependent information used for the SPDIF in compressed mode, can be set by the user. Refer to IEC958 standard for more information. 0: Transmitted DTDI are extracted from the stream.										
PFC	1: PCMCROSS function enabled										

AUTODETECT_ENA

S/PDIF Autodetection Enable

7	6	5	4	3	2	1	0
							ENA

Address: 0xE0

Type: R/W

Software Reset: 0

Hardware: Reset: UND

Description:

The feature is only available for STA310 cut 2.0. This register is used to enable the autodetection on the S/PDIF. When high, the autodetection is present. When low, autodetection is disable.

The STA310 cut 2.0 is able to detect the following audio format changes on the S?PDIF input.

FROM	TO
AC3	PCM
AC3	MPEG
MPEG	AC3
MPEG	PCM
PCM	AC3
PCM	MPEG

The host must respond to the RST and LCK interrupt in order for the STA310 to take into account the change of the audio format.

AUTODETECT_SENS

S/PDIF Autodetection Sensitivity

7	6	5	4	3	2	1	0
SENS							

Address: 0xE1

Type: R/W

Software Reset: 0

Hardware: Reset: UND

Description:

The feature is only available for STA310 cut 2.0. This register is used to configure the autodetection sensitivity. The lower is SENS, the faster is the autodetection. Typical value is 0.

AUTODETECT_ALIGN

S/PDIF Autodetection Alignment

Address: 0xE2

Type: R/W

Software Reset: 0

Hardware: Reset: UND

Description:



The feature is only available for STA310 cut 2.0. This register is used to configure the Left/Right sample alignment of the S/PDIF. Typical value is 10

9.9 Audio command registers

SOFTRESET

Soft reset

7	6	5	4	3	2	1	0

Address: 0x10

Type: W0

Software Reset: NA

Hardware: Reset: NA

Description:

When bit 0 of this register is set, a soft reset occurs.

The command registers and the interrupt registers listed below are cleared.

The decoder goes into idle mode and the volumes are cleared.

Command registers:
MUTE, RUN, PLAY, SKIP_MUTE_CMD and SKIP_MUTE_VALUE

Interrupt registers:
INTE, INT and ERROR

PLAY

Play

7	6	5	4	3	2	1	0
							PLAY

Address: 0x13

Type: R/W

Software Reset: 0

Hardware: Reset: 0

Description:

The PLAY command is treated according to the state of the decoder:

- When in idle mode, the PLAY value is not taken into account by the decoder.
- When in init mode, the PLAY value is not taken into account by the decoder.
- When in decode mode, PLAY enables the decoding, see table below:

PLAY value	MUTE value	DAC_SCLK, DAC_LRCLK state	DAC_PC MOUT	Decoding
0	0	Not running	0	No
0	1	Running	0	No
1	0	Running	Decoded samples	Yes
1	1	Running	0	Yes

MUTE

Mute

7	6	5	4	3	2	1	0
							MUTE

Address: 0x14

Type: R/W

Software Reset: 0

Hardware: Reset: 0

Description:

The MUTE command is handled differently according to the state of the decoder:

- When in idle mode after hardware reset, setting MUTE to “1” automatically runs the DAC_SCLK and DAC_LRCLK clocks and outputs them to the DACs.
- When playing, setting MUTE to “1” mutes the PCM outputs.
- The MUTE register has no effect on the SPDIF output.

RUN

RUN decoding

7	6	5	4	3	2	1	0
							RUN

Address: 0x72

Type: R/W

Software Reset: 0

Hardware Reset: 0

Description:

This register enables to exit from idle mode. After a soft or hard reset the decoder is in idle mode. It stays in this mode until the RUN is set.

In run mode the decoder takes into account the state of all the configuration registers and begins to decode.

The RUN register can only be reset by the SOFTRESET command.

SKIP_MUTE_CMD

Skip or mute commands

7	6	5	4	3	2	1	0
reserved		MUTE	reserved	PAU	BLK	SKP	SMUT

Address: 0x73

Type: R/W

Software Reset: 0

Hardware Reset: 0

Description:

This register cannot be used in MP3 decoding mode. The register is taken into account at a beginning of decoding a frame.

Value	Description
SMUT, MUTE	If one or both of these bits is '1' then the decoder continues the normal decoding process, but the output samples are soft-muted to zero. When both these bits are '0' muting is disabled and the decoder plays the incoming frame.
SKP	Skip frame. The decoder skips the number of frames programmed in register
BLK	Pause block. The decoder introduces a delay equal to the number of blocks programmed in register
PAU	The decoder is stopped whilst this bit is '1'.
Reserved	Set to '0'.

SKIP_MUTE_VALUE

Skip frames or mutes blocks of frame

7	6	5	4	3	2	1	0

Address + 0x74

Type: R/W

Software Reset: 0

Hardware Reset: 0

Description:

The value in this register gives either the number of frames to skip or the number of blocks during which the decoder will be stopped. This is used in conjunction with register .

9.10 Interrupt register

INTE

Interrupt enable

	7	6	5	4	3	2	1	0
@0x08	INTE[15:8]							
@0x07	INTE[7:0]							

Address: 0x08 - 0x07

Type: R/W

Software Reset: 0

Hardware Reset: 0

Description:

This register is used to enable each interrupt independently. Setting a bit in the register enables the corresponding interrupt.

INT

Interrupt

	7	6	5	4	3	2	1	0
@0x0A	INTE[15:8]							
@0x09	INTE[7:0]							

Address: 0x0A - 0x09

Type: RO

Software Reset: 0

Hardware Reset: 0

Description: These registers indicate which interrupt occurred. Provided an interrupt is enabled through the register INTE, if the corresponding bit of INT is set, the corresponding interrupt has occurred. The signal IRQ is activated whenever one of the bits of INT become set. Depending on the nature of the condition, clearing a bit in INT register is performed by either reading the MSB of INT register, or by reading the MSB of the associated condition registers (see below). This register is reset by software reset. The table below shows the interrupt nature indicated by each bit..

Bit Numer	Name	Condition Signalled
0	SYN	Change in Synchronization Status ⁽¹⁾
1	HDR	Valid Header Registered ⁽¹⁾
2	ERR	Error Detected ⁽¹⁾
3	SFR	Sampling frequency changed ⁽²⁾
4	DEM	De-emphasis Changed ⁽²⁾
5	BOF	First Bit of New Frame at Output Stage ⁽²⁾
6	PTS	First Bit of New Frame with PTS at Output Stage ⁽²⁾
7	ANC	Not implemented
8	PCM	PCM Output Underflow ⁽²⁾
9	FBF	Frame Buffer Full: The frame buffer memory contains 2 frames: one decoded, and one parsed for next decoding
10	FBE	Frame Buffer Empty: The frame buffer memory contains 1 frame which begins to be decoded. The next frame begins to be parsed

Bit Numer	Name	Condition Signalled
11	FIO	FIFO Input has Overflowed ⁽²⁾
12	RST ⁽³⁾	The STA310 has detected a change in the incoming audio format. The soft Reset produce must be applied and the device must be re-initialized according to the new audio format detected. Registers DECODESEL (0x4d) and STREAMSEL (0x4c) contain the new audio format ⁽¹⁾
13	LCK ⁽³⁾	A break has occurred in the S/PDIF stream causing the internal S/PDIF PLL to get unlocked. The soft reset procedure must be applied and the device must be re-initialized according to the current audio format decoding contained in the registers DECODESEL (0x4d) and SRTREAMSEL (0x4c). ⁽¹⁾
14	USD	Reserved
15	TBD	Reserved

Notes: 1. Cleared when a reset occurs or when the MSB of the interrupt register is read
 2. Cleared when a reset occurs or when the MSB of the corresponding register is read. Affected registers are listed in the following table
 3. Only available in STA310 cut 2.0

Address	Name
0x0F	ERROR
0x40	SYNCSTATUS
0x41	ANCCOUNT
0x42	HEAD 4
0x46	PTS [32]

9.11 Interrupt status registers

SYNC_STATUS

Synchronization status

7	6	5	4	3	2	1	0
				PAC		FRA	

Address: 0x40

Type: RO

Software Reset: UND

Hardware Reset: UND



Description:

This register indicates the status of the audio parser for synchronization. It is used in conjunction with PACKET_LOCK and SYNCK_LOCK registers. On read the synchronization status interrupt bit is cleared (INT.SYN is cleared).

Bitfield	Description
FRA	Frame Status 0 0: Research audio synchronization 0 1: Wait for confirmation - a synchro word has been detected but the parser has not yet detected SYNC-LOCK+1 synchro words. 1 0: Synchronized - SYNC_LOCK + 1 synchro words have been detected 1 1: Not used
PAC	Packet Status 0 0: Research packet synchronization word 0 1: Wait for confirmation - a synchro word has been detected but the parser has not yet detected PACKET_LOCK+1 synchro words. 1 0: Synchronized - PACKET_LOCK + 1 synchro words have been detected 1 1: Not used

ANCCOUNT

Ancillary data

7	6	5	4	3	2	1	0

Address: 0x41

Type: RO

Software Reset: UND

Hardware Reset: UND

Description:

This value gives the number of ancillary data in the stream. The ancillary data interrupt bit ANC of the register is cleared by a read.

HEAD4

HEADER 4 register

AC_3

7	6	5	4	3	2	1	0
0	0	0	0	0	BSMOD		

MPEG_2

0	0	0	0	0	0	DR	K
---	---	---	---	---	---	----	---

OTHER

0	0	0	0	0	0	0	0
---	---	---	---	---	---	---	---

Address: 0x42

Type: RO

Software Reset: UND

Hardware Reset: UND

Description:

This register contains header data HEAD[31:24]. The contents depend on the type of the frame. HEAD4[7:3] = 00000, in all cases.

When the host reads this register, the corresponding interrupt bit (HDR) is cleared.

Dolby Digital

Bitfield	Description
HEAD4[2:0]	BSMOD if an Dolby Digital frame

MPEG-2

Bitfield	Description
HEAD4[2]	0
HEAD4[1]	DR=1 Dynamic range exists
HEAD4[0]	K=0 in normal mode, K=1 in Karaoke mode.

OTHER

In all other types of frame HEAD4[2:0] = "000"

HEAD3

HEADER 3 register

7	6	5	4	3	2	1	0
0	0	0	DTYPE				

Address: 0x43

Type: RO

Software Reset: UND

Hardware Reset: UND

Description:



STA310

This register contains header data HEAD[23:16].HEAD3[7:5]="000", in all cases HEAD3[4:0] = DTYPE

DTYPE is the data type and is defined as follows:

Bit	Description
DTYPE	0000: Null data or Linear PCM
	0001: Dolby Digital
	0100: MPEG-1 Layer I
	0101: MPEG-1 Layer II or MPEG-2 word extension
	0110: MPEG-2 Layer II with extension
	1001: MPEG-2 Layer II low sample rate
	(11) 1011: DTS-1 (Frame Size 512)
	(12) 1100: DTS-2 (Frame Size 1024)
	(13) 1101: DTS-3 (Frame Size 2048)

This register can not detect the data-type of data in a stream.

HEADLEN

Frame length

7	6	5	4	3	2	1	0
HEADLEN[15:8]							
HEADLEN[7:0]							

Address: 0x44 - 0x45

Type: RO

Software Reset: UND

Hardware Reset: UND

Description:

The HEADLEN register contains the bit length of the compressed data frame HEAD[15:0]. HEADER registers are all updated as soon as the decoder begins to decode a frame.

PTS

PTS

	7	6	5	4	3	2	1	0
0x46								PTS[32]
0x47	PTS[31:24]							
0x48	PTS[23:16]							
0x49	PTS[15:8]							
0x4A	PTS[7:0]							

Address: 0x46 to 0x4A

Type: R/W

Software Reset: UND

Hardware Reset: UND

Description:

When the PTS interrupt is activated, a new PTS value is stored in this register. Once the PTS[32] value is read bit PTS of the PTS register is cleared.

ERROR

ERROR code

7	6	5	4	3	2	1	0

Address + 0x0F

Type: RO

Software Reset: 0

Hardware Reset: 0

Description:

This is a status register, when read by the ST20, this and the corresponding interrupt register are cleared. This 7-bit register is ANDed with 0x7F to get the correct value. The value in the ERROR register indicates the type of error that has occurred. These errors are defined in the table below.

Error Name	Value (decimal)
Dolby Digital decoding	
No error	0
EXPAND_DELTA_PAST_END_ARRAY	1
XDCALL_TRY_TO_REUSE_REMAT_FLG	2
XDCALL_TRY_TO_REUSE_COUPLING_STRA	3
XDCALL_CANT_COUPLE_IN_DUAL_MODE	4
XDCALL_TRY_TO_REUSE_CPL_LEAK	5
XDCALL_TRY_TO_REUSE_SNR	6
XDCALL_TRY_TO_REUSE_BIT_ALLOC	7
XDCALL_TRY_TO_REUSE_COUPLING_EXPONENT_STRA	8
XDCALL_TRY_TO_REUSE_EXPONENT_STRA	9
XDCALL_TRY_TO_REUSE_LFE_EXPONENT_STRA	10
XDCALL_CHBWCOD_IS_TOO_HIGH	11

Error Name	Value (decimal)
BSI_ERR_REV	12
BSI_ERR_CHANS	13
CRC_NOT_VALID	14
Packet Synchronization	
SYNCHRO_PACKET_NOT_FOUND	16
BAD_MPEGI_RESERVED_WORD	17
BAD_MPEG2_RESERVED_WORD	18
BAD_LPCM_SYNCHRO	19
UNKNOWN_STREAM_ID	20
MARKER_ERROR	21
UNKNOWN_SUB_STREAM_ID	22
IEC958_INPUT_MISMATCH_CONF	23
IEC958_MPEG2_LAYER1_NOT_SUPPORTED	24
IEC958_PAUSE_FRAME_NOT_SUPPORTED	25
IEC958_BAD_DATA_TYPE_DEPENDANT	26
MISMATCH_HOST_SEL_CONFIGURATION	27
Audio Synchronization	
SYNCHRO_AUDIO_NOT_FOUND	32
BAD_CRC_AC3	33
BAD_LPCM_QUANTIZATION_WORDLENGTH	34
BAD_AUDIO_SAMPLING_FREQUENCY	35
BAD_MPEG_LAYER	36
MPEG_BITRATE_FREE_FORMAT	37
NOT_SUPPORTED_AC-3_FRMSIZECOD	38
BAD_CRC_MPEG_EXTENDED	39
BAD_MPEG_EXTENDED_RESERVED_BIT	40
MPEG_EXTENDED_SYNC_NOT_FOUND	41
MPEG_EXTENDED_LENGTH_TOO_SMALL	42
BAD_SAMPLES_PER_CHANNEL	44
BAD_FRAME_BIT_SIZE	45
MPEG Decoding	
MPEG_EXTENSION_ERROR	48
MPEG_MC_MUTE	49
NOT USED	50
NOT USED	51
MPEG_LAYER_ERROR	52
MPEG_CHCONFIG_ERROR	53
MPEG_MC_PREDICTION_ERROR	54
MPEG_CRC_ERROR	55
MPEG_EXT_CRC_ERROR	56
MPEG_TOO_SMALL_FOR_MC_HEADER	57

Error Name	Value (decimal)
MPEG_BITRATE_ERROR	58
MP3 Decoding	
CRC_ERROR	01
DATA_AVAILABLE_ERROR	02
ANC_PARTIAL_READ_ERROR	03
ANC_NOT_READ_ERROR	04
BAD_ID_AND_IDEX_VALUES	33
LAYER_IS_NOR_LAYER3	34
BAD_audio_sampling_freq	35
FREE_FORMAT_NOT_SUPPORTED	36
BIT_RATE_NOT_SUPPORTED	37
BIG_VALUE_ERROR	48
MODE_CHANGE_ERROR	49
FS_CHANGE_ERROR	50
Miscellaneous	
IEC_958_READ_ERROR	64
MPEG_FB_BYPASS_AREA_ERROR	65
SKIPPING_BITS_IN_FB_ERROR	66
LATENCY_TOO_BIG	67
SKIP_MUTE_ERROR	68
UNKNOWN_SFREQ_FOR_LATENCY	69
LATENCY_TOO_SMALL	70
BAD_INPUT_CHAN	71
INVALID_ALPHA_COEFF	72

9.12 Decoding algorithm registers

The table below shows how the STREAMSEL and DECODESEL registers should be programmed for different types of bitstream.

Table 9. STREAMSEL and DECODESEL programming definitions

STREAMSEL (0x4C)	DECODESEL (0x4D)	Mode
0	0	MPEG2 PES carrying Dolby Digital (ATSC)
0	1	MPEG2 PES carrying MPEG1 frames
0	2	MPEG2 PES carrying MPEG2 frames
1	0	MPEG2 PES carrying Dolby Digital frames for DVD video

1	2	MPEG2 PES carrying MPEG2 frames for DVD video
1	3	MPEG2 PES carrying linear PCM for DVD video
2	1	MPEG1 packet carrying MPEG1 audio
3	0	Dolby Digital frames elementary streams
3	1	MPEG1 frame elementary streams
3	2	MPEG2 frame elementary stream
3	3	Stereo PCM (16bits samples) and PCM2 channels
3	4	Pink noise generator
3	5	CDDA (Stereo PCM 16 bits samples)
3	7	Activate PCM beep tone
3	9	MP3 elementary streams
5	0	IEC61937 Input with Dolby Digital frames
5	1	IEC61937 Input with MPEG1 frames
5	2	IEC61937 Input with MPEG2 frames
5	6	IEC61937 Input with DTS frames
6	3	Linear PCM for DVD audio

DECODSEL

Decoding algorithm

7	6	5	4	3	2	1	0
				DEC			

Address: 0x4D
 Type: R/W
 Software Reset: NC
 Hardware Reset: UND

Description:

This register identifies the audio data-type.

Bitfield	Description
DEC[3:0]	0000: Dolby Digital Decoding 0001: MPEG1 0010: MPEG2 0011: PCM/LPCM 0100: PINK NOISE generator 0101: CD_DA 0111: PCM beep tone generator 1001: MP3

STREAMSEL

STREAM selection

7	6	5	4	3	2	1	0
					STRSEL		

Address: 0x4C
 Type: R/W
 Software Reset: NC
 Hardware Reset: UND
 Description:

Bitfield	Description
STRSEL	000: PES 001: PES DVD video 010: Packet MPEG1 011: Elementary Stream/IEC60958 100: Reserved 101: SPDIF IEC61937 110: PES DVD audio

9.13 System synchronization registers

PACKET_LOCK

Packet lock

7	6	5	4	3	2	1	0

Address: 0x4F
 Type: R/W
 Software Reset: NC
 Hardware Reset: UND



Description:

This register specifies the number of supplementary packet synchro words that the packet parser must detect before it is considered as synchronized, and can send data to the audio parser (max=1, min=0). In this way, stream data can not be sent to the audio parser instead of packet sync words.

PACKET_LOCK = 0: the packet parser is synchronized when it has detected one packet synchro word.

PACKET_LOCK = 1: the packet parser is synchronized when it has detected two packet synchro words.

ID_EN

Enable audio ID

7	6	5	4	3	2	1	0

Address: 0x50

Type: R/W

Software Reset: NC

Hardware Reset:UND

Description:

If set to 1, the audio decoder decodes only the stream corresponding to the stream-id or sub-stream-id of the packet layer. This selection is done through AUDIO_ID or AUDIO_ID_EXT registers. If set to 0, the decoder decodes all the audio packets.

ID

Audio ID

7	6	5	4	3	2	1	0

Address : 0x51

Type: R/W

Software Reset: NC

Hardware Reset: UND

Description:

When decoding packets, it is possible to specify an identifier for a selected program. AUDIO_ID must be written with the packet ID. This feature is enabled when the register AUDIO_ID_EN is set, and only packets with matching ID are decoded.

For MPEG1 packets or PES, the 5 LSB bits are significant. For DVD PES (LPCM, Dolby Digital or MPEG), the 3 LSB bits are significant (see audio pack definition in DVD specifications).

These bits correspond to the stream number defined in the STREAM_ID field of the audio packet header, except for DVD, Dolby Digital or LPCM packets, where they correspond to the stream number defined in the SUB_STREAM_ID field.

ID_EXT

Audio extension

7	6	5	4	3	2	1	0

Address + 0x52

Type: R/W

Software Reset: NC

Hardware Reset: UND

Description:

The 3 LSB bits of this register are significant. In case of DVD MPEG2 audio with extension bitstream (see DVD specifications), this register is used to select the stream defined in the STREAM_ID of the packets containing MPEG2 extension bit stream data.

SYNC_LOCK

SYNC lock

7	6	5	4	3	2	1	0

Address: 0x53

Type: R/W

Software Reset: NC

Hardware Reset: UND

Description:

This register specifies the number of supplementary audio synchro words that the audio parser must detect before it is considered as synchronized, and can send data to the decoder.

In this way, stream data can not be sent to the decoder instead of audio sync words. Max value = 3; min value = 0. SYNC_LOCK = 0, the audio parser is synchronized when it has detected one audio synchro word. SYNC_LOCK = n > 0, when the audio parser has detected one synchro word, it waits until it detects n supplementary audio sync words.

When it has detected (SYNC_LOCK+1) sync words, it sends the data to the decoder.

9.14 Post decoding and pro logic registers

PDEC1

Post decoder register

7	6	5	4	3	2	1	0
VMAX		DEM	DCF	DB	PVIRT	MPEG_DR	PL

Address: 0x62

Type: R/W

Software Reset: NC

Hardware Reset: UND

Description:

This register controls the post decoder operations.

Bitfield	Description
PL	When high Pro Logic decoding is forced, when low the ProLogic decoder is automatically enabled when the stream contains the info that it is ProLogic encoded
MPEG_DR	When high enable MPEG dynamic range.
DB	When high the "double stereo" procedure is enabled. Double stereo is a copy of Left/Right channels on to Left/Right surround channels in order to have a pseudo 5 -channel decoder effect.
DCF	When set the DC filter is activated.. When reset, it is disabled.
DEM	When set the de-emphasis filter is activated.. When reset, it is disabled.

PL_AB

Pro Logic auto balance

7	6	5	4	3	2	1	0
						PL_WS	PL_AB

Address : 0x64

Type: R/W

Software Reset: NC

Hardware Reset: UND

Description:

Bitfield	Description
PL_AB	When high, select the auto-balance function (used to track out gin mismatches between Lt and Rt).When low, disable the autobalance function
PL_WS	When high, enable Wide Surround mode. The wide surround option is provided for users who plan to do further post-processing of the Pro Logic outputs, and want to fold the lowpass filtering of the surround channel into their downstream processing Lowpass filtering and B-type shelf filtering are both disabled. When low, disable ide surround mode.

PL_DWNX

Pro Logic Decoder Downmix

7	6	5	4	3	2	1	0
				LFE_BYP	PL_DWNX[2:0]		

Address : 0x65

Type: R/W

Software Reset: NC

Hardware Reset: UND

Description:

Bitfield	Description
PL_DWNX [2:0]	0,1,2: Pro Logic disabled 3: 3/0 (L, R, C) three stereo 4: 2/1 (L, R, Ls) phantom 5: 3/1 (L, C, R, Ls) 6: 2/2 (L, R, Ls, Rs) phantom 7: 3/2 (L, C, R, S, S)
LFE_BYP	0: LFE channel is clear 1: LFE channel is bypassed

Prologic decoder support only 4 sampling frequencies: 48KHz, 44.1KHz, 32KHz, 22.05KHz.

If we active prologic with sampling frequency different from those frequencies, the decoder will be automatically disable the prologic call.

OCFG

Output Configuration

7	6	5	4	3	2	1	0
LFE_BYP	BOOST				OCFG[2:0]		

Address: 0x66



Type: RW
 Software Reset: NC
 Hardware Reset: UND

The description is provided in the output configuration section.

This register is used to indicate the output configuration chosen.

- LP means Low pass filter
- HP means High pass filter

Description:

6 output configurations are provided that redirects bass on subwoofer channel, and applies some filters on channels.

Bitfield	conf	Meaning	Description
OCFG[2:0]			Bass management configuration according to the bass direction scheme from Dolby. For configurations 2,3,4 the subwoofer can be output is bit LFE asset to high. For all other configurations, the LFE bit has no effect.
	0	ALL	All channels are rounded according to the selected output precision, (24b -> 16b, 24 -> 18b.) and scaled (volume control) only.
	1	LSW	Low frequencies are extracted from the six input channels and redirected to the subwoofer. SUB = LP(L+R+Ls+Rs+C+LFE).Low frequencies are removed from all channels L = HP(L), R = HP(R), C = HP(C), Ls = HP(Ls), Rs = HP(Rs).
	2	LLR	Low frequencies are extracted from C, LFE, Ls and Rs channels and redirected to left and right channels: C = HP (C), Rs = HP (Rs), Ls = HP(Ls), L = L + LP (C+LFE+Ls+Rs), R = R + LP(C+LFE+Ls+Rs). If subwoofer is output, SUB = LP (LFE+C+Ls+Rs).
	3 ⁽¹⁾	SLP	Low frequencies are redirected to the left, right and surround channels or can be output on the subwoofer. If sub-woofer is output, SUB = LFE, L = L + LP(C), R = R + LP(C), Ls = Ls, Rs = Rs If sub-woofer is not output, L = L + LP(C) + LFE, R = R + LP(C) + LFE, Ls = Ls + LFE, Rs = Rs + LFE.
	4	SIMP	Simplified configuration. Low frequencies are extracted from C, Ls, Rs and LFE. If subwoofer is output, SUB = LP(C+Ls+Rs) + LFE, L = L, R = R. If sub-woofer is not output, SUB = LFE, L = L + (C+Ls+Rs), R = R + (C+Ls+Rs).
	5	BYP	BYPASS, All channels are directly routed to PCM outputs.
	6		configuration 1 without filters.
BOOST ⁽¹⁾	Channel level, enables boost: if OCFG_num = 2 : 0 : No +12dB boost on left and right channels 1 : +12dB boost on left and right channels When configuration = 3 : If sub-woofer is output : 0 : No +4dB boost on all channels 1 : +4dB boost on all channels If sub-woofer is not output : 0 : No +8dB boost on all channels 1 : +8dB boost on all channels		
LFE_BYOP	0: LFE channel is clear 1: LFE channel is bypassed		

Note: 1. In configuration 3 with subwoofer enabled, the output of the subwoofer is 10dB greater than expected. Therefore when using this mode, the subwoofer output level needs to be attenuated 10dB in order to match the subwoofer output levels of other bass management configurations. In general be careful while using the boost option since it has the potential of causing the woofer output to overload

DWSMODE



Downsampling filter

7	6	5	4	3	2	1	0

Address: 0x70

Type: R/W

Software Reset: NC

Hardware Reset: UND

Description:

This register controls the downsampling filter for the LPCM video, LPCM audio modes. When decoding a 96kHz DVD-LPCM stream, it might be necessary to downsample the stream to 48kHz.

Value	Mode
0	Automatic (according to bitstream)
1	Force Downsampling
2	Suppress Downsampling

9.15 Bass redirection registers

VOLUME0

Volume of first channel

7	6	5	4	3	2	1	0
AVol0							

Address: 0x4E

Type: RWS

Software Reset: 0

Hardware Reset: UND

Description:

This register reads or writes the attenuation that is applied to the channel selected by CHAN_IDX. The volume of the left channel can be set up with a 0.5dB step.

- If CHAN_IDX = 0, then VOLUME0 can be written with the attenuation that will be applied to Left channel.
- If CHAN_IDX = 1, then VOLUME0 can be written with the attenuation that will be applied to Center channel.

- If CHAN_IDX = 2, then VOLUME0 can be written with the attenuation that will be applied to Left Surround channel.
- If CHAN_IDX = 5, then reading VOLUME0 provides the attenuation that is applied to Left channel.
- If CHAN_IDX = 6, then reading VOLUME0 provides the attenuation that is applied to Center channel.
- If CHAN_IDX = 7, then reading VOLUME0 provides the attenuation that is applied to Left Surround channel.
- Other values of CHAN_IDX are reserved.

VOLUME1

Volume of second channel

7	6	5	4	3	2	1	0
AVol1							

Address: 0x63

Type: RWS

Software Reset: 0

Hardware Reset: UND

Description:

This register reads or writes the attenuation that is applied to the channel selected by CHAN_IDX. The volume of the right channel can be set up with a 0.5dB step.

- If CHAN_IDX = 0, then VOLUME1 can be written with the attenuation that will be applied to Right channel.
- If CHAN_IDX = 1, then VOLUME1 can be written with the attenuation that will be applied to Subwoofer channel.
- If CHAN_IDX = 2, then VOLUME1 can be written with the attenuation that will be applied to Right Surround channel.
- If CHAN_IDX = 5, then reading VOLUME1 provides the attenuation that is applied to Right channel.
- If CHAN_IDX = 6, then reading VOLUME1 provides the attenuation that is applied to Subwoofer channel.
- If CHAN_IDX = 7, then reading VOLUME1 provides the attenuation that is applied to Right Surround channel.
- Other values of CHAN_IDX are reserved.

CHAN_IDX

Channel Index

7	6	5	4	3	2	1	0
Reserved					CHAN_IDX		

Address: 0x67

Type: R/W

Software Reset: 4

Hardware Reset: UND

Description:

This register identifies the pair of channels and the type of access:

Bitfield	value	Channel pair	Access	comment
CHAN_IDX	0	Left and Right	write	
	1	Center and Subwoofer	write	
	2	Left surround and right surround	write	
	3	reserved	reserved	
	4	no pair selected	none	Indicates that volume can be read or written
	5	Left and Right	read	
	6	Center and Subwoofer	read	
	7	Left surround and right surround	read	

- To read a volume, the register CHAN_IDX must be set to the appropriate value. The DSP indicates that the attenuation is readable through registers VOLUME0 and VOLUME1 by changing automatically the CHAN_IDX to value 4.
- To write a volume, the attenuation of the pair of channel should be written in VOLUME0 and VOLUME1 registers. Then the CHAN_IDX register is written to the appropriate value. The attenuation is updated on the next audio block

and CHAN_IDX value is automatically changed to 4.

9.16 Dolby Digital configuration registers

AC3_DECODE_LFE

Decode LFE

7	6	5	4	3	2	1	0

Address: 0x68

Type: R/W

Software Reset: NC

Hardware Reset: UND

Description:

When this register is set to 1, the device decodes LFE channel (if present).

AC3_COMP_MOD

Compression mode

7	6	5	4	3	2	1	0

Address + 0x69

Type: R/W

Software Reset: NC

Hardware Reset: UND

Description:

The value of this register defines the compression mode. In custom A mode, the dialog normalization function is not done by the audio decoder, it has to be done by an external analog part. In all other modes the normalization is done by audio decoder.

Value	Meaning
0	Custom A (Analog)
1	Custom D (Digital)
2	Line Out
3	RF Mode

AC3_HDR

High dynamic range

7	6	5	4	3	2	1	0

Address: 0x6A
 Type: R/W
 Software Reset: NC
 Hardware Reset: UND

Description:
 This register corresponds to the Dynamic range scale factor for high level signals, also called cut factor in the Dolby specifications.
 $HDR = 255 * \text{Cut Factor}$ (in decimal), where the cut factor is a fractional number between 0 and 1. It is used to scale the dynamic range control word for high-level signals that would otherwise tend to be reduced.
 When HDR = 0xff (cut factor = 1.0), the high level signals reduction is the one given in the stream.
 A value of zero disables the high-level compression. This word is ignored if the compression mode is set to RF mode.

AC3_LDR

Low dynamic range

7	6	5	4	3	2	1	0

Address : 0x6B
 Type: R/W
 Software Reset: NC
 Hardware Reset: UND

Description:
 This register corresponds to the Dynamic range scale factor for low level signals, also called boost factor in the Dolby specifications.
 $LDR = 255 * \text{BoostFactor}$ (in decimal), where the boost factor is a fractional number between 0 and 1.0. The boost factor scales the dynamic range control-word for low-level signals that would otherwise tend to be amplified.
 When LDR = 0xff (boost factor = 1.0), and the low

level signals amplification is maximum.
 A value of zero disables the low-level amplification. This word is ignored if the compression mode is set to RF mode.

AC3_RPC

Repeat count

7	6	5	4	3	2	1	0

Address + 0x6C
 Type: R/W
 Software Reset: NC
 Hardware Reset: UND

Description:
 When a CRC error is detected, previous blocks can be repeated or muted.
 This register specifies the number of audio blocks to repeat before muting. If this is zero, then blocks are muted until the next frame is decoded

AC3_KARAMODE

Karaoke downmix

7	6	5	4	3	2	1	0

AudioBaseAddress + 0x6D
 Type: R/W
 Software Reset: NC
 Hardware Reset: UND

Description:
 Downmix mode when a karaoke bit stream is received.
 A Karaoke bitstream can be composed of 5 channels, which are: L (left), R (right), M (Music), V1 (Vocal 1), V2 (Vocal 2).
 There are two major modes when receiving a Karaoke bitstream: aware and capable.
 When in 'aware' mode (KARAMODE = 0), a predefined downmix is applied on all incoming channels.
 When in 'capable' mode (KARAMODE = 4, 5, 6, 7), the user can choose to reproduce or not the two in-



coming vocal channels, V1 and V2.

An additional mode is added (AC3_KARAMODE = 3) to allow multi-channel reproduction. In this case, the downmix specified by the AC3_DOWNMIX and AC3_DUALMODE registers is applied.

The following table summaries the different modes:

Value	Mode	Comment
0	Aware	Left = L + clev*M + slev*V1, Right = R + clev*M + slev*V2
1		Not used
2		Not used
3	Multichannel	Consider bitstream as multi-channel: Perform downmix according to DOWNMIX and DUALMODE registers
4	Capable	Do not reproduce V1, V2: Left = L + clev*M, Right = R + clev*M
5		Reproduction V1 only: Left = L + clev*M + 0.707*V1, Right = R + clev*M + 0.707V1
6		Reproduction V2 only: Left = L + clev*M + 0.707*V2, Right = R + clev*M + 0.707V2
7		Reproduction V1, V2: Left = L + clev*M + V1, Right = R + clev*M + V2

Left = Output Channel,
Right = Output Channel, L, R, M, V1, V2 = Input Channels (coded in Dolby Digital karaoke bitstream),
clev = Center Mix Level (value provided in the bitstream),

slev = Surround Mix Level (value provided in the bitstream). For further information ref. to annex C of ATSC standard "Digital Audio Compression (AC-3)".

AC3_DUALMODE

Dual downmix

7	6	5	4	3	2	1	0

Address: 0x6E

Type: R/W

Software Reset: NC

Hardware Reset: UND

Description

This register allows additional downmix to be set

when in 2/0 output mode or when receiving a "Dual mode" incoming bitstream (example: A disk with 2 different languages on channel 1 and channel 2). In the following table, channel 1 and 2 represent the output channels after downmix performed with AC3_DOWNMIX.

This register enables Mono downmix when AC3_DOWNMIX = 2 and AC3_DUALMODE = 3.

Value	Description
0	Output as Stereo
1	Output Channel 1 on both output L/R
2	Output Channel 2 on both output L/R
3	Mix Channel 1 and 2 to monophonic and output on both L/R

AC3_DOWNMIX

Downmix

7	6	5	4	3	2	1	0

Address: 0x6F

Type: R/W

Software Reset: NC

Hardware Reset: UND

Description:

Value	Description
0	2/0 Dolby Surround (LT, RT)
1	1/0 (C)
2	2/0 (L, R)
3	3/0 (L, C, R)
4	(L, R, S)
5	3/1 (L, C, R, S)
6	2/2 (L, R, LS, RS - Dolby Phantom Mode)
7	3/2 (L, C, R, Ls, Rs)

Note: in notation, 3/2 represents 3 front speakers and 2 surround speakers.

AC3_STATUS0



Dolby Digital status register

7	6	5	4	3	2	1	0
Not used		fs_cod		Bitrate code			

AudioBaseAddress + 0x76

Type: RO

Software Reset: NC

Hardware Reset:UND

Description:

This register contains bit stream information extracted from the stream.

Bitfield	Description
Bitrate code	Code identifying the bitrate. Bitrate[4..0] = frmsizecod[5..1]
fs_cod	Code identifying the sampling frequency

Dolby Digital status register 2

7	6	5	4	3	2	1	0
Bsmod				Bsid			

Address + 0x78

Type: RO

Software Reset: NC

Hardware Reset:UND

Description:

This register contains bit stream information extracted from the stream.

Bitfield	Description
Bsid	Bit stream identification, indicates the version of the standard
Bsmod	Bbit stream mode, indicates the type of service

AC3_STATUS1

Dolby Digital status register 1

7	6	5	4	3	2	1	0
Reserved				LFE	Acmod		

Address: 0x77

Type: RO

Software Reset: NC

Hardware Reset:UND

Description:

This register contains bit stream information extracted from the stream.

Bitfield	Description
Acmod	Audio coding mode. Indicates which channels are in use.
LFE	Indicates if LFe channel is present in the stream

AC3_STATUS3

Dolby Digital status register 3

7	6	5	4	3	2	1	0
Reserved				Cmixlevel		SurMixlevel	

Address: 0x79

Type: RO

Software Reset: NC

Hardware Reset: UND

Description:

This register contains bit stream information extracted from the stream.

Bitfield	Description
Cmixlevel	Downmix level of center channel
SurMixlevel	Downmix level of surround channel

AC3_STATUS2

AC3_STATUS4

Dolby Digital status register 4

7	6	5	4	3	2	1	0
Reserved		Dsurmod	Copyright	Origbs	Lancode		

Address: 0x7A

Type: RO

Software Reset: NC

Hardware Reset: UND

Description:

This register contains bit stream information extracted from the stream.

Bitfield	Description
Lancode	When at 1, indicates that a language code is provided in the stream
Origbs	When at 1, indicates that the stream is an original
Copyright	When at 1, indicates that the stream is protected by copyright
Dsurmod	In 2/0 mode, indicates if the stream is Dolby surround encoded

AC3_STATUS5

Dolby Digital status register 5

7	6	5	4	3	2	1	0
Lancode							

Address : 0x7B

Type: RO

Software Reset: NC

Hardware Reset: UND

Description:

This register contains the code of the language of the audio service, extracted from the stream.

AC3_STATUS6

Dolby Digital status register 6

7	6	5	4	3	2	1	0
Reserved			Dialog Normalization (see Dolby specifications)				

Address:0x7C

Type: RO

Software Reset: NC

Hardware Reset: UND

Description:

This register contains the code indicating the dialog normalization level extracted from the stream.

AC3_STATUS7

Dolby Digital status register 7

7	6	5	4	3	2	1	0
Room type		Mix level				Audprodie	

Address: 0x7D

Type: RO

Software Reset: NC

Hardware Reset: UND

Description:

This register contains bit stream information extracted from the stream.

Bitfield	Description
Audprodie	Audprodie: if set, indicates that room type and mix level are provided
Mix level	If audprodie is set, mix level indicates the sound level
Room type	If audprodie is set, mix level indicates the sound level

9.17 MPEG configuration registers

MP_SKIP_LFE

Channel skip

7	6	5	4	3	2	1	0
Reserved							

Address : 0x68

Type: R/W

Software Reset: 0x00

Hardware Reset: UND

Description:

When this register is set to 1, the LFE channel is skipped. When this register is set to 0 the LFE channel is decoded (if present).

MP_PROG_NUMBER

Program number

7	6	5	4	3	2	1	0
Reserved							Prog

Address: 0x69

Type: R/W

Software Reset: 0x00

Hardware Reset: UND

Description:

When the stream is in Second Stereo mode, this register specifies which program is played.

Bitfield	Description
Prog	Select program #0 or #1 where 0: L0,R0 in front channels, 1: L2,R2 in front channels

MP_DUALMODE

MPEG setup dual mode

7	6	5	4	3	2	1	0
Reserved							

Address: 0x6E

Type: R/W

Software Reset: 0x00

Hardware Reset: UND

The MPEG DUAL_MODE is active in downmix mode 1 and 9.

Value	Description
0	Output as Stereo
1	Output Channel 1 on both outputs L/R
2	Output Channel 2 on both outputs L/R
3	Mix Channel 1 and 2 to monophonic, and output on both L/R

MP_DRC

Dynamic range control

7	6	5	4	3	2	1	0
Reserved							DRC

Address: 0x6A

Type: R/W

Software Reset: 0x00

Hardware Reset: UND

Description:

When bit DRC=1, dynamic range control is enabled. The dynamic range is set according to the data transmitted in the DVD MPEG stream.

MP_CRC_OFF

CRC check off

7	6	5	4	3	2	1	0
Reserved							

Address: 0x6C

Type: R/W

Software Reset: NC

Hardware Reset: UND

Description:

When register is set to 1, the CRC in MPEG frame is not checked. When register is set to 0, the CRC in MPEG frame is checked if exists. If a CRC error occurs, the decoder soft mutes the frame (but does not stop).

MP_MC_OFF

Multi-channel

7	6	5	4	3	2	1	0
Reserved			DEN	Reserved			MC

Address: 0x6D

Type: R/W

Software Reset: NC

Hardware Reset: UND

Description:

Bitfield	Description
MC	When MC=1, the multi-channel part of the bitstream is not decoded, only the MPEG-1 compatible bitstream is decoded. Bit MC must be set to 1 for an MPEG-1 bitstream.
DEN	De-normalization: set DEN=0 for MPEG1 signals, and set DEN=1 for MPEG2 multi-channel signals When DEN=1, MPEG2 multi-channel signals L, C, R, LS and RS can be de-normalized. The signals must first be inverse-weighted then multiplied by the de-normalization factor. This undoes the attenuation carried out at the encoder side to avoid overload when calculating the compatible signals (see MPEG 13818-3 specifications).

MP_DOWNMIX
MPEG downmix

7	6	5	4	3	2	1	0

Address: 0x6F

Type: R/W

Software Reset: 0x08

Hardware Reset: UND

Description:

In the table below, L_O, R_O, C_O, L_{S_O}, R_{S_O} represent the output channels after downmix, and L, R, C, L_S, R_S are the audio channels.

The coefficients K_j, K_C, K_r, K_S, depend on the number of input channels. In the above table, the equations are given for a 5 channels input bitstream. If the input bitstream does not contain five channels (L, C, R, L_S, R_S), the coefficient "K_j" corresponding to the channel not present is equal to 0.

If the MPEG bitstream contains only one surround channel (S), replace (K_S x (L_S + R_S)), (K_S x L_S and

(K_S x R_S) by (K_S x S) in the above equations.

Value	Output Mode	Comment
0x00	1/0 (C) = Mono	C _O = K _j x L + C + K _r x R + K _S (L _S + R _S)
0x01	2/0 (L, R) = Stereo	L _O = (L + K _C x C + K _S x L _S) / (1 + K _C + K _S), R _O = (R + K _C x C + K _S x R _S) / (1 + K _C + K _S)
0x02	3/0 (L, C, R)	L _O = L + K _S x L _S , R _O = R + K _S x R _S , C _O = C
0x03	2/1 (L, R, S)	L _O = L + K _C x C, R _O = R + K _C x C, L _{S_O} = R _{S_O} = K _S x (L _S + R _S)
0x04	3/1 (L, C, R, S)	L _O = L, R _O = R, C _O = C, L _{S_O} = R _{S_O} = K _S x (L _S + R _S)
0x05	2/2 (L, R, L _S , R _S)	L _O = L + K _C x C, R _O = R + K _C x C, L _{S_O} = L _S , R _{S_O} = R _S
0x06	3/2 (L, C, R, L _S , R _S)	L _O = L, R _O = R, C _O = C, L _{S_O} = L _S , R _{S_O} = R _S
0x09	2/0 (Dolby surround L _T , R _T)	L _T = (L + 0.707C - 0.707 x 0.5 (L _S + R _S)) / 2.414, R _T = (R + 0.707C + 0.707 x 0.5 (L _S + R _S)) / 2.414
0x0A	2/0 Karaoke capable: V1 ON, V2 ON	L _k = L + 0.707 A1 + 0.707 G, R _k = R + 0.707 A2 + 0.707 G
0x0B	2/0 Karaoke Capable: V1 ON, V2 OFF	L _k = L + 0.707 A1 + 0.707 G, R _k = R + 0.707 G
0x0C	2/0 Karaoke Capable: V1 OFF, V2 ON	L _k = L + 0.707 G, R _k = R + 0.707 A2 + 0.707 G
0x0D	2/0 Karaoke Capable: V1 OFF, V2 OFF	L _k = L + 0.707 G, R _k = R + 0.707 G
0x0E	2/0 Karaoke Capable: V1 ON, V2 OFF (Dolby Digital like)	L _k = L + 0.707 A1 + 0.707 G, R _k = R + 0.707 A1 + 0.707 G
0x0F	2/0 Karaoke Capable: V1 OFF, V2 ON (Dolby Digital like)	L _k = L + 0.707 A2 + 0.707 G, R _k = R + 0.707 A2 + 0.707 G
0x1A	3/0 Karaoke Capable: V1 ON, V2 ON	L _k = L + 0.707 A1, C _k = G, R _k = R + 0.707 A2

0x1B	3/0 Karaoke Capable: V1 ON, V2 OFF	Lk = L + 0.707 A1, Ck = G, Rk = R
0x1C	3/0 Karaoke Capable: V1 OFF, V2 ON	Lk = L, Ck = G, Rk = R + 0.707 A2
0x1D	3/0 Karaoke Capable: V1 OFF, V2 OFF	Lk = L, Ck = G, Rk = R
0x1E	3/0 Karaoke Capable: V1 ON, V2 OFF (Dolby Digital like)	Lk = L, Ck = G + A1, Rk = R
0x1F	3/0 Karaoke Capable: V1 OFF, V2 ON (Dolby Digital like)	Lk = L, Ck = G + A2, Rk = R

MP_STATUS0

MPEG status register 0

7	6	5	4	3	2	1	0
ID	LAY[1:0]	P	BRI[3:0]				

Address : 0x76

Type: RO

Software Reset: UND

Hardware Reset: UND

Description:

Bitfield	Description
BRI[3:0]	Bit rate index
P	Protection Bit
LAY[1:0]	Layer
ID	Identifier

MP_STATUS1

MPEG status register 1

7	6	5	4	3	2	1	0
SFR[1:0]	PAD	PRI	MOD[1:0]	MEX[1:0]			

Address: 0x77

Type: RO

Software Reset: UND

Hardware Reset: UND

Description:

Bitfield	Description
MEX[1:0]	Mode Extension
MOD[1:0]	Mode
PRI	Private Bit
PAD	Padding Bit
SFR[1:0]	Sampling Frequency

MP_STATUS2

MPEG status register 2

7	6	5	4	3	2	1	0
not used				C	OCB	EMP[1:0]	

Address: 0x78

Type: RO

Software Reset: UND

Hardware Reset: UND

Description:

Bitfield	Description
EMP[1:0]	Emphasis rate index
OCB	Original/Copy Bit
C	Copyright

MP_STATUS3

MPEG status register 3

7	6	5	4	3	2	1	0
CEN[1:0]	SUR[1:0]	LFE	AMX	DEM[1:0]			

Address : 0x79

Type: RO

Software Reset: UND

Hardware Reset: UND

Description:

Bitfield	Description
DEM[1:0]	Dematrix procedure
AMX	Audio mix
LFE	LFE
SUR[1:0]	Surround
CEN[1:0]	Centre

MP_STATUS4

MPEG status register 4

7	6	5	4	3	2	1	0
EXT	NML[2:0]		MFS	MLY	CIB	CIS	

Address: 0x7A

Type: RO

Software Reset: UND

Hardware Reset: UND

Description:

Bitfield	Description
CIS	Copyright ID Start
CIB	Copyright ID Bit
MLY	Multi-lingual Layer
MFS	Multi-lingual FS
NML[2:0]	Number of Multi-lingual Channels
EXT	Extension bitstream present

MP_STATUS5

MPEG status register 5

7	6	5	4	3	2	1	0

Address: 0x7B

Type: RO

Software Reset: UND

Hardware Reset: UND

Description:

The number of extended ancillary data bytes is contained in this register

9.18 Pink noise generation registers

PN_DOWNMIX

Pink noise downmix

7	6	5	4	3	2	1	0
		RS	LS	LFE	C	R	L

Address: 0x6F

Type: R/W

Software Reset: NC

Hardware Reset: UND

Description:

Bitfield	Description
L	1: Left channel contains pink noise 0: Left channel is forced to zero
R	1: Right channel contains pink noise 0: Right channel is forced to zero
C	1: Center channel contains pink noise 0: Center channel is forced to zero
LFE	1: LFE channel contains pink noise 0: LFE channel is forced to zero
LS	1: Left surround channel contain pink noise 0: Left surround channel is forced to zero
RS	1: Right surround channel contains pink zero 0: Right surround channel is forced to zero

After this processing, the OCFG stage is applied on these channels. OCFG must be configured to 0 and attenuation on all channels must be set to 10dB attenuation.

The other values must not be used because low frequency extraction must not be done when generating pink noise.

Pink noise selection is made through the STREAMSEL and DECODESEL registers.

9.19 PCM beep-tone registers

PCM_BTONE

PCM beep tone frequency

7	6	5	4	3	2	1	0

Address: 0x68

Type: R/W
 Software Reset: 0
 Hardware Reset: UND

Description:
 The value in this register sets the PCM beep tone frequency according to the formula:
 $Beep_tone_frequency = (Fs/2)/(Register_value+1)$

9.20 Karaoke registers

This section describes the registers which select the karaoke effects, for example: volume, chorus, echo, reverb and mute. Any change to these registers must be signalled to the DSP by writing 1 to the register.

KAR_MCh0VOL

Music channel 0 (L) volume

7	6	5	4	3	2	1	0
value							

Address: 0x81
 Type: R/W
 Reset value: 0xFF

Description;
 This register contains the scaling factor applied to the left channel of the music input. It specifies a fractional multiplication factor whose value varies from 0 to 1.0:
 Music Left channel = original music left channel $scale_factor$.

Bitfield	Description
Value	0x00: Scale factor 0 = left channel mute 0x7F: Scale factor 0.5 = half restitution of left channel 0xFF: Scale factor 1.0 = full restitution of left channel

KAR_MCh1VOL

Music channel 1 (R) volume

7	6	5	4	3	2	1	0
value							

Address: 0x82
 Type: R/W
 Reset value: 0xFF

Description:
 This register has the same function as KAR_MCh0VOL for the right music channel.

KAR_KEYCONT

Key control (Pitch Shift) ON/OFF

7	6	5	4	3	2	1	0
Reserved							PSHIFT

Address: 0x83
 Type: R/W
 Reset value: 0

Description:

Bitfield	Description
PSHIFT	0: pitch shift disabled, 1: pitch shift enabled

KAR_KEYVALUE

Key value

7	6	5	4	3	2	1	0
KEYVALUE							

Address: 0x84
 Type: R/W
 Reset value: 0x00

Description:
 The pitch shift can be changed from -3.5 to 3.5 tones, in steps of 1/4 tone. This register sets the number of tones according to the following table:

Key control (tone)	-1/4	-1/2	-3/4	-1	-1.1	-1.3	-1.5	-1.9	-2.49	-3.5
KEYVALUE (decimal)	0	1	2	3	4	5	6	7	8	9

Key control (tone)	1/4	1/2	3/4	1	1.16	1.34	1.58	1.93	2.49	3.5
KEYVAL UE (decimal)	10	11	12	13	14	15	16	17	18	19

KAR_VCANCEL

Voice cancellation ON/OFF

7	6	5	4	3	2	1	0
Reserved							VCANCEL

Address: 0x85

Type: R/W

Reset value: 0

Description:

Bitfield	Description
VCANCEL	0: voice cancellation off, 1: voice cancellation on

KAR_VVALUE

Degree of voice cancellation

7	6	5	4	3	2	1	0
Reserved					LEVEL[2:0]		

Address: 0x86

Type: R/W

Reset value: 0x0

Description:

When the voice cancellation is enabled by the KAR_VCANCEL register, KAR_VVALUE specifies the extent of the voice cancellation according to the following table:

Bitfield	Description
LEVEL[2:0]	0: cut-band filter with 40dB attenuation at 700Hz 1: cut-band filter with 35dB attenuation at 700Hz 2: cut-band filter with 32dB attenuation at 700Hz 3: cut-band filter with 27dB attenuation at 700Hz 4: cut-band filter with 23dB attenuation at 700Hz

KAR_MMUTE

Music channel mute

7	6	5	4	3	2	1	0
Reserved							MUTE

Address: 0x87

Type: R/W

Reset value: 0

Description:

This register mutes the music channel.

Bitfield	Description
MUTE	0: not muted, 1: muted

KAR_VCh0VOL

Voice channel 0 (L) volume

7	6	5	4	3	2	1	0
Value							

Address: 0x88

Type: R/W

Reset value: 0xFF

Description:

This register has the same function as KAR_MCh0VOL for the left voice channel instead of the left music channel.

KAR_VCh1VOL

Voice channel 1 (R) volume

7	6	5	4	3	2	1	0
Value							

Address: 0x89

Type: R/W

Reset value: 0xFF

Description:

This register has the same function as KAR_MCh0VOL for the right voice channel instead of the left music channel.

KAR_DUET

Duet ON/OFF switch

7	6	5	4	3	2	1	0
Reserved							DUET

Address: 0x8A

Type: R/W

Reset value: 0

Description:

The value in this register sets the duet function on or off. When selected, the duet function is configured by register KAR_DUETTHRESH.

Bitfield	Description
DUET	0: duet off and 1: duet on

KAR_DUETTHRESH

Duet threshold control

7	6	5	4	3	2	1	0
DUETTHRESHOLD[7:0]							

Address + 0x8B

Type: R/W

Reset delay: 0

Description:

When the Duet function is enabled by the KAR_DUET register, this register specifies the amplitude of the voice line below which the voice is cancelled. If the amplitude of the voice line is below this threshold, the recorded voice is played instead. The value of DUETTHRESHOLD ranges from 0 to 255, full scale signal.

KAR_VOICE

Selection of voice effects

7	6	5	4	3	2	1	0
Reserved					MIX	VOICEEFF[1:0]	

Address: 0x8C

Type: R/W

Reset delay: 0x0

Description:

Bitfield	Description
VOICEEFF	Select the voice effects: 0: No effect is applied to the voice input 1: Echo is applied to the voice inputs, tuned by registers KAR_VDELAY and KAR_VBAL 2: Chorus is applied to the voice inputs, tuned by registers KAR_VDELAY and KAR_VBAL 3: Reverb is applied to the voice inputs, tuned by register KAR_VDELAY.
MIX	Voice channel mixing: 0: No mix, voice is output on centre channel 1: Mix music and voice channels into music channel.

KAR_VDELAY

Programmable delay/decay music effects

7	6	5	4	3	2	1	0
Value							

Address: 0x8D

Type: R/W

Reset value: 0x0

Description:

The value in this register specifies the delay used for voice input effects. The delay can be set in the range from 0 to 2048/Fs seconds (where Fs is the sampling frequency in KHz).

$$\text{'desired time delay'} = (2048 / Fs) * (\text{Value} / 256)$$

which gives:

$$\text{KAR_VDELAY value} = (Fs / 8) * \text{'desired time delay'}$$

For reverberation effects, this register gives the decay factor, which can vary within the range 0 to 1.0.

KAR_VBAL

Programmable mix for echo and chorus effects

7	6	5	4	3	2	1	0
BALANCE[7:0]							

Address: 0x8E

Type: R/W

Reset value: 0x3F



Description:

This register sets the balance between the original sound and its delayed version for the echo and chorus effects according to the formula.

echo (or chorus) output = original_sound * (1 - balance) + delayed_sound * balance

where balance = Balance[7:0] / 255

where balance can vary in the range of 0 to 1. A balance limit of 0.5 is recommended. BALANCE[7:0] = balance * 255.

KAR_VMUTE

Voice channel mute

7	6	5	4	3	2	1	0
Reserved							MUTE

Address: 0x8F

Type: R/W

Reset value: 0x00

Description:

This register mutes the voice channel: '0' means not muted and '1' means muted.

KAR_PLAY

Mute of voice and music

7	6	5	4	3	2	1	0
Reserved							PLAY

Address: 0x90

Type: R/W

Reset value: 0x01

Description:

This register mutes the voice and the music channels simultaneously: PLAY = '0' means muted and '1' means playing. The registers and KAR_VMUTE have priority for muting.

KAR_MODE

Operating mode selection

7	6	5	4	3	2	1	0
Reserved						KAR_MODE[1:0]	

Address + 0x91

Type: R/W

Reset value: 0x01

Description:

This register specifies the working mode of the Karaoke module.

Bitfield	Description
KAR_MODE [1:0]	<p>00: Karaoke processor in waiting mode. This is the default mode after a hardware reset, total or partial software reset. This mode is used to programme all the registers at first initialization.</p> <p>01: Karaoke processor running.</p> <p>10: Partial Software reset. This resets the internal DSP program but keep the register configuration as it was before the partial reset. When the partial reset is finished, KAR_MODE[1:0] is automatically set to '01'.</p> <p>11: Total Software reset. The program is reset and the registers values are changed back to their reset default values.</p>

KAR_DIN_CTL

Control of voice channel

7	6	5	4	3	2	1	0
Reserved	JUSTIF	DELAY	WS_P OL	CLK_P OL	WS[1:0]		DINEN

Address: 0x92

Type: R/W

Reset Value: 0x00

Description:

This register specifies the input format for configuring

the handling of the second input.

Bitfield	Description
DINEN	DIN enable: 0: disabled, 1: enabled
WS[1:0]	PCM precision: 00: 16-bit mode, 01: 18-bit mode, 10: 20-bit mode, 11: 24-bit mode
CLK_POL	0: Data and WS change on clockalling edge 1: Data and WS change on clockising edge
WS_POL	0: Left data word = WS low, right data word = WS high 1: Left data word = WS high, right data word = WS low
DELAY	0: First bit of data occurs on transition of WS 1: First bit of data occurs with 1 clock cycle delay (I2S compatible)
JUSTIF	0: Left padded, 1: Right padded

KAR_UPDATE

Change active Karaoke functions

7	6	5	4	3	2	1	0
Reserved							UPDATE

Address: 0x93
Type: R/W
Reset Value: 0

Description:
This register loads the new Karaoke configuration into the internal registers when UPDATE is set to '1'. When the bit is reset to '0' the system continues in the configuration last loaded.

9.21 Second serial input registers

SFREQ2

Sampling frequency of voice channel

7	6	5	4	3	2	1	0
Reserved							Value

Address: 0x94
Type: RO
Reset Value: 0

Description:

This register sets the sampling frequency, Fs, of the incoming PCM stream.

Fs (KHz)	48	44.1	32	-	96	88.2	64	-	24	22.05
Value (decimal)	0	1	2	3	4	5	6	7	8	9

Fs (KHz)	16	-	12	11.025	8	-	192	176.4	128	-
Value (decimal)	10	11	12	13	14	15	16	17	18	19

CANINPUT_MODE

Selection of input data format

7	6	5	4	3	2	1	0
SWAP	MODE[6:0]						

Address: 0x95
Type: R/W
Reset Value: 0x00

Description;
This register specifies the input format for configuring the handling of the second input.

Bitfield	Description
MODE [6:0]	0: 16 slots mode 1: 16 slots mode, LSB first 2: 32 slots mode, left aligned 3: 32 slots mode, right aligned 4: 32 slots mode, I2S mode 5: 32 slots mode, sign extended 6: 32 slots mode, 8-bit data 7: 32 slots mode 16-bit data
SWAP	Channel swap: 0: Left channel first, 1: Right channel firs

9.22 Linear PCM (DVD audio) registers

LPCMA_DOWNMIX

Downmix

7	6	5	4	3	2	1	0
Reserved							Value

Address: 0x6F
Type: R/W
Software Reset: NC



Hardware Reset: UND

Description;:

Value	Description
0	Downmix not applied
1	Force downmix 2/0
2	Downmix 2/0 is applied if the flags down_mix_code_validity AND stereo_playback_mode are both '0' in the bitstream

The notation, 2/0 represents 2 front speakers and no surround speakers.

LPCMA_FORCE_DWS

Downsampling 192 to 96KHz

7	6	5	4	3	2	1	0
Reserved						Value	

Address : 0x70

Type: R/W

Software Reset: NC

Hardware Reset: UND

Description:

This register selects whether downsampling is used for input streams requiring sampling frequencies of 192KHz or 176.4KHz. When 'automatic' is selected, register is automatically updated to correspond to the new output frequency.

Bitfield	Description
Value	00: Automatic (if Fs = 192KHz or 176.4KHz) 01: Automatic (if Fs = 192KHz or 176.4KHz) 10: No downsampling

LPCMA_DM_COEFT_0

Downmix phase coefficients 0

7	6	5	4	3	2	1	0
0	PH_1L	PH_2L	PH_3L	PH_4L	PH_5L	Reserved	

Address : 0x97

Type: R/W

Software Reset: NC

Hardware Reset: UND

Description:

This register sets the phase coefficients for channels mixing to Lmix. The input signal is inverted when PH_xL = '0' and non-inverted when '1'.

LPCMA_DM_COEFT_1

Downmix phase coefficients 1

7	6	5	4	3	2	1	0
PH_0R	0	PH_2R	PH_3R	PH_4R	PH_5R	Reserved	

Address: 0x98

Type: R/W

Software Reset: NC

Hardware Reset: UND

Description:

This register sets the phase coefficients for channels mixing to Rmix. The input signal is inverted when PH_xR = '0' and non-inverted when '1'.

LPCMA_DM_COEFT_2

Downmix gain coefficients 2

7	6	5	4	3	2	1	0
COEF_0L							

Address: 0x99

Type: R/W

Software Reset: NC

Hardware Reset: UND

Description:

This register sets the mixing gain for Lf to Lmix. See the note after register

LPCMA_DM_COEFT_3

Downmix gain coefficients 3

7	6	5	4	3	2	1	0
COEF_0R							

Address : 0x9A

Type: R/W

Software Reset: NC

Hardware Reset: UND

Description:

This register sets the mixing gain for Lf to Rmix. See the note after register

LPCMA_DM_COEFT_4

Downmix gain coefficients 4

7	6	5	4	3	2	1	0
COEF_1L							

Address: 0x9B

Type: R/W

Software Reset: NC

Hardware Reset: UND

Description:

This register sets the mixing gain for Rf to Lmix. See the note after register
<BlueHT>LPCMA_DM_COEFT_13.

LPCMA_DM_COEFT_5

Downmix gain coefficients 5

7	6	5	4	3	2	1	0
COEF_1R							

Address: 0x9C

Type: R/W

Software Reset: NC

Hardware Reset: UND

Description:

This register sets the mixing gain for Rf to Rmix. See the note after register
<BlueHT> LPCMA_DM_COEFT_13.

LPCMA_DM_COEFT_6

Downmix gain coefficients 6

7	6	5	4	3	2	1	0
COEF_2L							

Address: 0x9D

Type: R/W

Software Reset: NC

Hardware Reset: UND

Description:

This register sets the mixing gain for C to Lmix. See the note after register .

LPCMA_DM_COEFT_7

Downmix gain coefficients 7

7	6	5	4	3	2	1	0
COEF_2R							

Address: 0x9E

Type: R/W

Software Reset: NC

Hardware Reset: UND

Description:

This register sets the mixing gain for C to Rmix. See the note after register

LPCMA_DM_COEFT_8

Downmix gain coefficients 8

7	6	5	4	3	2	1	0
COEF_3L							

Address: 0x9F

Type: R/W

Software Reset: NC

Hardware Reset: UND

Description:

This register sets the mixing gain for Ls / S to Lmix. See the note after register

LPCMA_DM_COEFT_9

Downmix gain coefficients 9

7	6	5	4	3	2	1	0
COEF_3R							

Address : 0xA0

Type: R/W

Software Reset: NC

Hardware Reset: UND

Description:

This register sets the mixing gain for Ls / S to Rmix. See the note after register

LPCMA_DM_COEFT_10

Downmix gain coefficients 10

7	6	5	4	3	2	1	0
COEF_4L							

Address : 0xA1

Type: R/W

Software Reset: NC

Hardware Reset: UND

Description:

This register sets the mixing gain for Rs to Lmix. See the note after register .

LPCMA_DM_COEFT_11

Downmix gain coefficients 11

7	6	5	4	3	2	1	0
COEF_4R							

Address: 0xA2

Type: R/W

Software Reset: NC

Hardware Reset: UND

Description:

This register sets the mixing gain for Rs to Rmix. See the note after register
LPCMA_DM_COEFT_12

Downmix gain coefficients 12

7	6	5	4	3	2	1	0
COEF_5L							

Address: 0xA3

Type: R/W

Software Reset: NC

Hardware Reset: UND

This register sets the mixing gain for LFE to Lmix. See the note after register .

LPCMA_DM_COEFT_13

Downmix gain coefficients 13

7	6	5	4	3	2	1	0
COEF_5R							

Address: 0xA4

Type: R/W

Software Reset: NC

Hardware Reset: UND

Description:

This register sets the mixing gain for LFE to Rmix

Note: For DVD audio, the real coefficient value, alpha[x], applied to channel x is calculated with the following formulae:

$$\alpha[x] = 2^{-(COEF_xL/30)} \quad 0 < COEF_xL < 199$$

$$\alpha[x] = 2^{-((COEF_xL - 100)/30)} \quad 200 < COEF_xL < 254$$

$$\alpha[x] = 0 \quad COEF_xL \geq 255$$

LPCMA_STATUS0

Linear PCM (DVD audio) status register

7	6	5	4	3	2	1	0
EMPHASIS	Reserved	STEREO_PB	DWNMX_VALID	DOWN_MIX_CODE [3:0]			

Address: 0x76

Type: RO

Software Reset: NC

Hardware Reset: UND

Description:

This register contains bit stream information extracted from the stream.

Bitfield	Description
DOWN_MIX_CODE	Identifying code
DWNMX_VALID	DOWN_MIX_CODE valid
STEREO_PB	Stereo playback mode
EMPHASIS	Emphasis flag

LPCMA_STATUS1

Linear PCM (DVD audio) status register

7	6	5	4	3	2	1	0
QUANTIZATION_WORD_LENGTH_1[3:0]				QUANTIZATION_WORD_LENGTH_2[3:0]			



STA310

Address: 0x77

Type: RO

Software Reset: NC

Hardware Reset: UND

Description:

This register contains bit stream information extracted from the stream.

Bitfield	Description
QUANTIZATION_WORD_LENGTH_2[3:0]	Quantization word length for group 2
QUANTIZATION_WORD_LENGTH_1[3:0]	Quantization word length for group 1

LPCMA_STATUS2

Linear PCM (DVD audio) status register

7	6	5	4	3	2	1	0
SAMPLING_FREQUENCY_1[3:0]				SAMPLING_FREQUENCY_2[3:0]			

Address: 0x78

Software Reset: NC

Hardware Reset: UND

Description:

This register contains bit stream information extracted from the stream.

Bitfield	Description
SAMPLING_FREQUENCY_2[3:0]	Sampling frequency for group 2
SAMPLING_FREQUENCY_1[3:0]	Sampling frequency for group 1

LPCMA_STATUS3

Linear PCM (DVD audio) status register

7	6	5	4	3	2	1	0
Reserved				MULTI_CHANNEL_TYPE[3:0]			

Address: 0x79

Type: RO

Software Reset: NC

Hardware Reset: UND

Description:

This register contains bit stream information extracted from the stream.

Bitfield	Description
MULTI_CHANNEL_TYPE[3:0]	

LPCMA_STATUS4

Linear PCM (DVD audio) status register

7	6	5	4	3	2	1	0
BIT_SHIFT_OF_CHANNEL_GR2[3:0]				CHANNEL_ASSIGNMENT[3:0]			

Address: 0x7A

Type: RO

Software Reset: NC

Hardware Reset: UND

Description:

This register contains bit stream information extracted from the stream.

Bitfield	Description
CHANNEL_ASSIGNMENT[3:0]	
BIT_SHIFT_OF_CHANNEL_GR2[3:0]	

LPCMA_STATUS5

Linear PCM (DVD audio) status register

7	6	5	4	3	2	1	0
DYNAMIC_RANGE_CONTROL[7:0]							

Address: 0x7B

Type: RO

Software Reset: NC

Hardware Reset: UND

Description:

This register contains information, extracted from the stream, for the dynamic range control.

9.23 Linear PCM (DVD video and PCM) registers

LPCMV_DOWNMIX

Downmix

7	6	5	4	3	2	1	0
Reserved						Value	

Address : 0x6F

Type: R/W

Software Reset: NC

Hardware Reset: UND

Description:

Value	Description
0	Downmix not applied
1	Force downmix 2/0

The notation, 2/0 represents 2 front speakers and no surround speakers.

LPCMV_FORCE_DWS

Downsampling 96 to 48KHz

7	6	5	4	3	2	1	0
Reserved						Value	

Address: 0x70

Type: R/W

Software Reset: NC

Hardware Reset: UND

Description:

This register selects whether downsampling is used for input streams requiring a sampling frequency of 96KHz.

When 'automatic' is selected, register is automatically updated to correspond to the new output frequency.

Bitfield	Description
Value	00: Automatic (if Fs = 96KHz) 01: Automatic (if Fs = 96KHz) 10: No downsampling

LPCMV_DM_COEFT_0

Downmix phase coefficients 0

7	6	5	4	3	2	1	0
PH_0L	PH_1L	PH_2L	PH_3L	PH_4L	PH_5L	Reserved	

Address: 0x97

Type: R/W

Software Reset: NC

Hardware Reset: UND

Description:

This register sets the phase coefficients for channels mixing to Lmix. The input signal is inverted when PH_xL = '0' and non-inverted when '1'.

LPCMV_DM_COEFT_1

Downmix phase coefficients 1

7	6	5	4	3	2	1	0
PH_0R	PH_1R	PH_2R	PH_3R	PH_4R	PH_5R	Reserved	

Address: x98

Type: R/W

Software Reset: NC

Hardware Reset: UND

Description:

This register sets the phase coefficients for channels mixing to Rmix. The input signal is inverted when PH_xR = '0' and non-inverted when '1'.

LPCMV_DM_COEFT_2

Downmix gain coefficients 2

For details see register 0x99

LPCMV_DM_COEFT_3

Downmix gain coefficients 3

For details see register 0x9A

LPCMV_DM_COEFT_4

Downmix gain coefficients 4

For details see register 0x9B

LPCMV_DM_COEFT_5

Downmix gain coefficients 5

For details see register 0x9C

PCMV_DM_COEFT_6

Downmix gain coefficients 6

For details see register 0x9D

LPCMV_DM_COEFT_7

Downmix gain coefficients 7

For details see register 0x9E

LPCMV_DM_COEFT_8

Downmix gain coefficients 8

For details see register 0x9F

LPCMV_DM_COEFT_9

Downmix gain coefficients 9

For details see register 0xA0

PCMV_DM_COEFT_10

Downmix gain coefficients 10

For details see register 0xA1

LPCMV_DM_COEFT_11

Downmix gain coefficients 11

For details see register 0xA2

LPCMV_DM_COEFT_12

Downmix gain coefficients 12

For details see register 0xA3

LPCMV_DM_COEFT_13

Downmix gain coefficients 13

For details see register 0xA4

Note: For DVD video & PCM, the real coefficient value, alpha[x], applied to channel x is calculated with the following formulae:

$$\alpha[x] = 2^{-(x+(y/30))} \quad 0 < Y, 29 \quad 0 < X, 7$$

COEF_xL = register bits [b7,b6,b5,b4,b3,b2,b1,b0]

X = register bits[b7,b6,b5]

Y = register bits[b4,b3,b2,b1,b0]

LPCMV_STATUS0

7	6	5	4	3	2	1	0
EMPH_FLAG	MUTE_FLAG	Reserved	FRAME_NUM				

Address: 0x76

Type: R/W

Reset Value: UND

Description:

Bitfield	Description
FRAME_NUM	frame number of the first access unit in the group of audio frames
Reserved	Set to 0
MUTE_FLAG	0: mute off, 1: mute on
EMPH_FLAG	Emphasis status after the first access unit: 0: emphasis off; 1: emphasis on

LPCMV_STATUS1

7	6	5	4	3	2	1	0
Word_Length		Samp_Freq		Reserved	Channels		

Address :0x77

Type: R/W

Reset Value: UND

Description:

Bitfield	Description
Channels	Number of audio channels:000=1 channel (mono), 001=2 channels (stereo), 010=3 channels, 011=4 channels, 100=5 channels,101=6 channels, 110=7 channels, 111=8 channels
Reserved	Set to 0
Samp_Freq	Sampling frequency: 00=48kHz, 01=96kHz, 10=reserved, 11=reserved
Word_Length	Audio sample length: 00=16 bits, 01=20 bits, 10=24 bits, 11=reserved

PCMV_STATUS2

7	6	5	4	3	2	1	0
Dyn_Range_Control							

Address : 0x78
 Type: RW
 Reset Value: UND

Description:

This register sets the dynamic range compression from the first access unit. For the hexadecimal value 0x80, dynamic range control is not set. For all other values, the dynamic range control is $(24.082 - 6.0206 * X - 0.2007 * Y)$ dB, where $X = \text{dynamic_range_control}[7..5]$ and $Y = \text{dynamic_range_control}[4..0]$.

LPCMV_CH_ASSIGN

Channel assignment

7	6	5	4	3	2	1	0
Reserved				Value			

Address: 0xA8
 Type: R/W
 Software Reset: NC
 Hardware Reset: UND

Description:

Value	Description
Value (decimal)	This register configures the audio channels: See "DVD Specifications for Read-Only Disc", Part 4 AUDIO SPECIFICATIONS, Version 1.0, March 1999, Table C.1-2.

PCMV_MULTI_CHS

Multi channels

7	6	5	4	3	2	1	0
Reserved							Value

Address: 0xA9
 Type: R/W
 Software Reset: NC
 Hardware Reset: UND

Description:

Value	Description
Value (decimal)	This register configures the multi channel structure for the output channels: 0: Stereo 1: Multi channels

9.24 MLP registers

MLP_CRC

CRC check

7	6	5	4	3	2	1	0
reserved				SU_P	MA_S	MS_C	RH_C

Address: 0x6C
 Type: R/W
 Software Reset: NC
 Hardware Reset: UND

Description:

This register controls the four different CRCs in MLP. If the check is false, an error is returned (error numbers 80-83 in register and the outputs of all 6 channels are muted

Bitfield	Description
RH_C	1: Check of 'Restart_Header_CRC' enable
MS_C	1: Check of 'Major_Sync_CRC' enable
MA_C	1: Check of 'Max_Shift' enable
SU_P	1: Check of 'Substream_Parity' enable

MLP_DOWNMIX

Downmix

7	6	5	4	3	2	1	0
DWNMIX[7:0]							

Address: 0x6F
 Type: R/W
 Software Reset: NC
 Hardware Reset: UND



Description:

This register controls the MLP downmix.

Bitfield	Description
DWNMIX [7:0]	0x00: 2/0 (L / R) 0x01: 2/0 ^(a) (Lo / Ro) (according to bitstream0) 0x02: 3/0 (L, R, C) 0x03: 2/1 (L, R, S) 0x04: 3/1 (L, C, R, S) 0x05: 2/2 (L, R, Ls, Rs) 0x06: 3/3 (L, C, R, Ls, Rs) For all other values there is no downmix.

(a) Downmix 1/0 (one channel only) is forbidden in DVD audio

MLP_DRC

Dynamic range control

7	6	5	4	3	2	1	0
DRC[7:0]							

Address : 0x6A

Type: R/W

Software Reset: NC

Hardware Reset:: UND

Description:

When this register = 0x00, the dynamic range control is disabled. When 0x01, the dynamic range control is enabled and the DRC information in the MLP stream is used.

MLP_FORCE_DWS

Downsampling 192 to 96kHz or 176.4 to 88.2kHz

7	6	5	4	3	2	1	0
Reserved						Value	

Address: 0x70

Type: R/W

Software Reset: NC

Hardware Reset: UND

Description:

This register selects whether downsampling is used for input streams requiring sampling frequencies of 192KHz or 176.4KHz. When 'automatic' is selected, register is automatically updated to correspond to the

new output frequency.

Bitfield	Description
Value	00: Automatic (if Fs = 192KHz or 176.4KHz) 01: Automatic (if Fs = 192KHz or 176.4KHz) 10: No downsampling

MLP_LFE

Decode LFE

7	6	5	4	3	2	1	0
LFE[7:0]							

Address: 0x68

Type: R/W

Software Reset: NC

Hardware Reset: UND

Description:

When this register = 0x00, LFE is not decoded and when 0x01, LFE is decoded.

MLP_STATUS0

MLP status 0 register

7	6	5	4	3	2	1	0
Reserved				FS_CODE[4:0]			

Address: 0x76

Type: R/W

Software Reset: NC

Hardware Reset: UND

Type:

This status register contains the sampling frequency codes..

Bitfield	Description
FS_COD E[4:0]	This list gives the codes and the corresponding sampling frequency. 0x09: 44.1KHz 0x0A: 48KHz 0x0D: 88.2KHz 0x0E: 96KHz 0x11: 176.4KHz 0x12: 192KHz 0x1F: Undefined The remaining codes are reserved.



MLP_STATUS1

MLP status 1 register

7	6	5	4	3	2	1	0
Reserved			CH_ASSIGN[4:0]				

Address : 0x77

Type: RO

Software Reset: NC

Hardware Reset: UND

Description:

This status register contains the channel assignment.

Bitfield	Description
CH_ASSIGN[4:0]	This gives the channel assignment: See "DVD Specifications for Read-Only Disc", Part 4 AUDIO SPECIFICATIONS, Version 1.0, March 1999, Table C.1-1.

MLP_STATUS2

MLP status 2 register

7	6	5	4	3	2	1	0
Reserved			NSUBSTR[3:0]				

Address: 0x78

Type: RO

Software Reset: NC

Hardware Reset: UND

Description:

This status register contains the number of sub-streams present in the audio frame.

MLP_STATUS3

MLP status 3 register

7	6	5	4	3	2	1	0
Reserved			SUBSTR_CODE[3:0]				

Address: 0x79

Type: RO

Software Reset: NC

Hardware Reset: UND

Description:

This status register contains the sub-stream information codes..

Bitfield	Description
SUBSTR_CODE [3:0]	2-channel decoder: bit0 = '1': sub-stream 0 is decoded bit1 = '1': a simplified decoder can be used for sub-stream 0 6-channel decoder: bit2 = '1': sub-stream 0 is decoded bit3 = '1': sub-stream 1 is decoded

9.25 De-emphasis register

DEEMPH

De-emphasis

7	6	5	4	3	2	1	0
reserved						D[1:0]	

Address: 0xB5

Type: R/WS

Software Reset: NC

Hardware Reset: UND

Description:

This register is used in MPEG, DVD_LPCM or CDDA modes; it is not supported in Dolby Digital.

In MPEG and DVD_LPCM modes, its register value is extracted from the bitstream. When the emphasis status changes (by setting bit DEM of the register), an interrupt is generated. In CDDA mode, the register value must be updated by the application.

The de-emphasis filter specified here is applied only if bit DEM of the register is set.

Bitfield	Description
D[1:0]	00: none, 01: 50/15µs, 10: reserved, 11: CCITT J.17

9.26 Auxilliary outputs registers

VCR_MIX

VCR outputs

7	6	5	4	3	2	1	0
reserved	STEREO	PRL	reserved	COPY	3D_VCR		

Address: 0xAE
 Type: R/WS??
 Software Reset: NC
 Hardware Reset: 0

Description:

Bitfield	Description
3D_VCR	This bit selects "3-D sound" on the VCR channels using SRS processing (depending on the PDEC registers and): 0: Standard sound (disable "3-D sound"), 1: Enable "3-D sound".
COPY	This bit is used to copy "Left/Right" channels to "VCR" channels: 0: no copy, 1: copy enable.
PRL	This bit enables a "ProLogic downmix" on the "VCR" channels: 0: Disable, 1: Enable.
STEREO	This bit enables a "2/0 downmix" on the "VCR" channels: 0: Disable, 1: Enable.

Note: 1. To have both "3-D sound" on the "VCR" and "Left/Right" channels, the setup is:
 VCR_MIX = 0x02 and PDEC = 0x40 for SRS processing,

VCR_LDLY
VCR left channel delay

7	6	5	4	3	2	1	0
LEFT_VCR_DELAY							

Address: 0xAF
 Type: R/WS??
 Software Reset: NC
 Hardware Reset: 0

Description:

This register contains the VCR left channel delay value. See note after next register description.

VCR_RDLY

VCR right channel delay

7	6	5	4	3	2	1	0
RIGHT_VCR_DELAY							

Address: 0xAF
 Type: R/WS??
 Software Reset: NC
 Hardware Reset: 0

Description:

This register contains the VCR right channel delay value. The values for LEFT_VCR_DELAY and RIGHT_VCR_DELAY are taken into account only when register.bit .DLY = '1'.

**9.27 Miscellaneous
 BREAKPOINT**

To be defined

7	6	5	4	3	2	1	0
Reserved							

Address + 0x2B
 Type: R/W
 Software Reset: NC
 Hardware Reset: 0

Description:

This register must be set to 0x08.

CLOCKCMD

To be defined

7	6	5	4	3	2	1	0
Reserved							

Address: 0x3A
 Type: R/W
 Software Reset: NC
 Hardware Reset: 0

Description:

This register must be set to 0x00.

INIT_RAM

RAM initialization

7	6	5	4	3	2	1	0
Reserved							RAM_INIT

Address : 0xFF

Type: RO

Software Reset: 1

Hardware Reset: 0

Description:

The register is used to signal when the STA310 has finished to boot.

After a soft reset or a hardware reset, or a hardware reset, the host processor must wait until INIT_RAM hold the value "1".

the host can then start to configure the STA310 according to its application

APPENDIX A OVERVIEW OF THE CHIP

This **STA310** is based on a very high performances low power general purpose DSP core, MMDSP+, and a set of dedicated peripherals. Internal audio and system PLL allows to configure the chip for a wide range of audio frequencies and DSP processing power (1 to 100 Mips).

A.1 Architectural Block Diagram

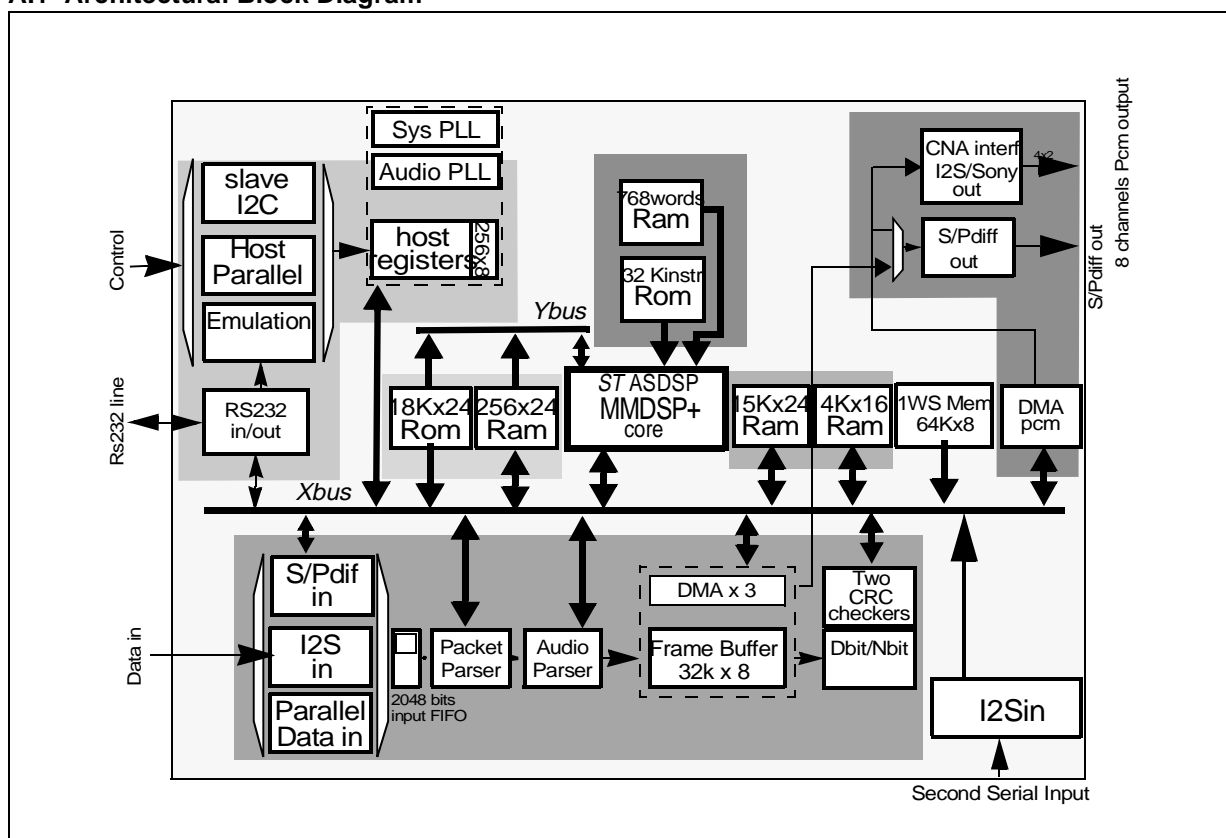

A.2 Description of the architecture

The MMDSP+ DSP core can access 5 banks of RAM/ROM memories:

- the 32K instruction ROM,
- the 768 words instruction development RAM,
- X_memory 19K x 24 RAM,
- Y_memory 18 K x 24 ROM,
- Y_memory 1K x 24 RAM.

The DSP core can also access some dedicated and general purpose peripherals. These peripherals (called MMIO peripherals) are mapped as memory locations of the X memory space of the MMDSP+ DSP core. On top of the front-end dedicated ones, the list of the peripherals is the following:

- Four PCM out *I2S/Sony* (16,18,20,24 bits) serial output interfaces are provided to connect, typically, to external DACs. This interface and the Audio PLL provide the Oversampling clocks and the serial clocks necessary to interface the DACs. This interface provides up to 8 independent audio channels. A "DMA PCM" MMIO block makes the link between the X data memory of the DSP core (which can store the audio samples) and the *I2S/Sony* serial interfaces. This MMIO block is a DMA (Direct Memory Access) and handles automatically the transfer of data by blocks. This peripheral implements also an hardware mechanism to support delayed channels. Each channel can be delayed (resolution 1 sample) by a programmable number of data samples. This function is totally transparent to the user.
- A 256 x 8 address space is shared between the MMDSP+ core (as MMIO peripheral) and the external world of the STA310 through the I2C Slave interface or the Host parallel interface. This area is divided mainly in 2 parts:
 - a 192 x 8 general purpose RAM area,
 - a 64 x (1 to 8 bits) area of specific registers.
- The two PLLs (Audio PLL and System PLL) can be controlled by the DSP itself (thru the MMIO bus) or by the external world of the STA310 (thru the I2C Slave I/F or the Host parallel I/F).

DIM.	mm			inch		
	MIN.	TYP.	MAX.	MIN.	TYP.	MAX.
A			1.60			0.063
A1	0.05		0.15	0.002		0.006
A2	1.35	1.40	1.45	0.053	0.055	0.057
B	0.22	0.32	0.38	0.009	0.013	0.015
C	0.09		0.20	0.003		0.008
D		16.00			0.630	
D1		14.00			0.551	
D3		12.35			0.295	
e		0.65			0.0256	
E		16.00			0.630	
E1		14.00			0.551	
E3		12.35			0.486	
L	0.45	0.60	0.75	0.018	0.024	0.030
L1		1.00			0.0393	
K	3.5°(min.), 7°(max.)					

OUTLINE AND MECHANICAL DATA

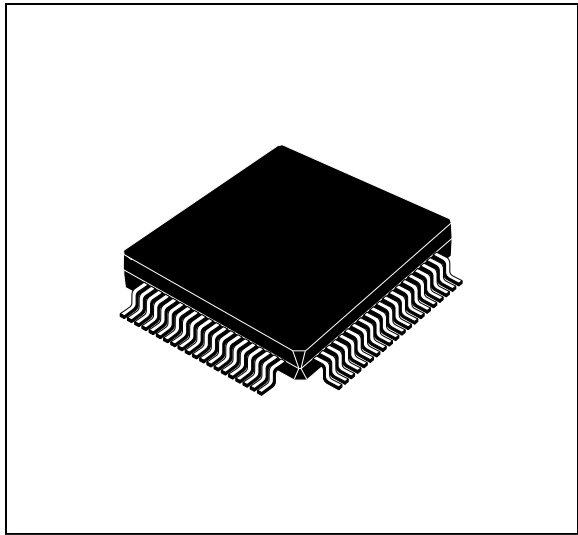

**TQFP80
(14x14x1.40mm)**

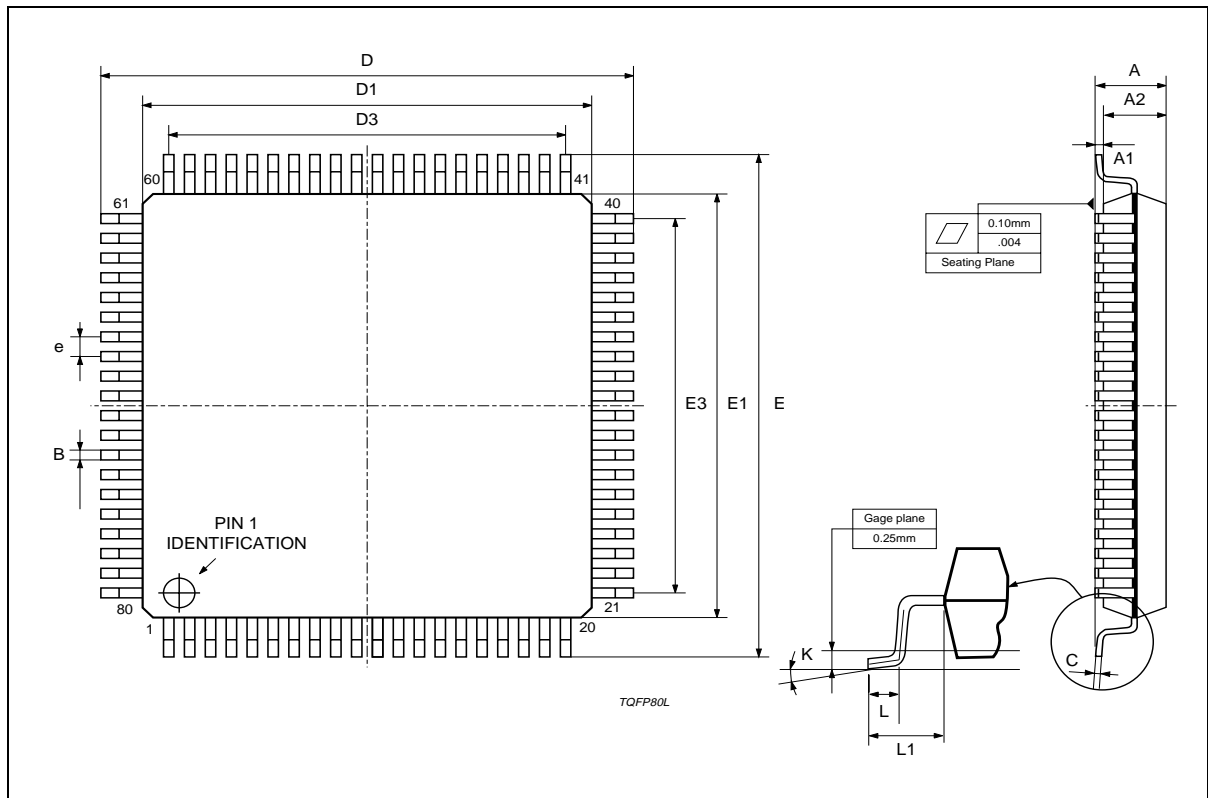

Information furnished is believed to be accurate and reliable. However, STMicroelectronics assumes no responsibility for the consequences of use of such information nor for any infringement of patents or other rights of third parties which may result from its use. No license is granted by implication or otherwise under any patent or patent rights of STMicroelectronics. Specifications mentioned in this publication are subject to change without notice. This publication supersedes and replaces all information previously supplied. STMicroelectronics products are not authorized for use as critical components in life support devices or systems without express written approval of STMicroelectronics.

The ST logo is a registered trademark of STMicroelectronics
© 2003 STMicroelectronics - All Rights Reserved

STMicroelectronics GROUP OF COMPANIES
Australia - Brazil - Canada - China - Finland - France - Germany - Hong Kong - India - Israel - Italy - Japan - Malaysia - Malta - Morocco -
Singapore - Spain - Sweden - Switzerland - United Kingdom - United States.
<http://www.st.com>

Copyright © Each Manufacturing Company.

All Datasheets cannot be modified without permission.

This datasheet has been download from :

www.AllDataSheet.com

100% Free DataSheet Search Site.

Free Download.

No Register.

Fast Search System.

www.AllDataSheet.com