

TOSHIBA BIPOLAR LINEAR INTEGRATED CIRCUIT SILICON MONOLITHIC

# TA7272P

## DUAL POWER OPERATIONAL AMPLIFIER

The TA7272P is a dual power operational amplifier. It is intended for use especially DC MOTOR positioning system applications, such as Arm Driver (for Audiodisk Players), head or voice coil motor drivers (for Floppy and Winchester Disk Drivers) and any other power driver applications.

### FEATURES

- HSIP 10Pin Power Package Capsealed.
- Build-in Over Current Protector.
- Few External Parts Required.
- Output Current Up to 1.2A (PEAK)
- Excellent Crosstalk Characteristics.

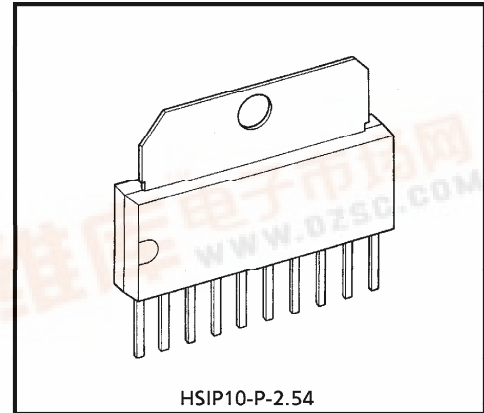

HSIP10-P-2.54

Weight : 2.47g (Typ.)

### BLOCK DIAGRAM

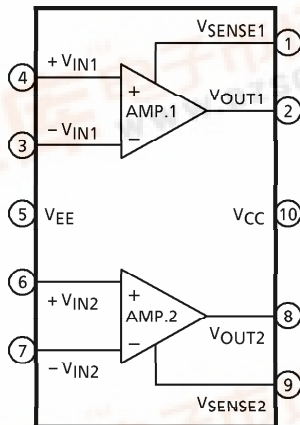

961001EBA2

- TOSHIBA is continually working to improve the quality and the reliability of its products. Nevertheless, semiconductor devices in general can malfunction or fail due to their inherent electrical sensitivity and vulnerability to physical stress. It is the responsibility of the buyer, when utilizing TOSHIBA products, to observe standards of safety, and to avoid situations in which a malfunction or failure of a TOSHIBA product could cause loss of human life, bodily injury or damage to property. In developing your designs, please ensure that TOSHIBA products are used within specified operating ranges as set forth in the most recent products specifications. Also, please keep in mind the precautions and conditions set forth in the TOSHIBA Semiconductor Reliability Handbook.
- The products described in this document are subject to foreign exchange and foreign trade control laws.
- The information contained herein is presented only as a guide for the applications of our products. No responsibility is assumed by TOSHIBA CORPORATION for any infringements of intellectual property or other rights of the third parties which may result from its use. No license is granted by implication or otherwise under any intellectual property or other rights of TOSHIBA CORPORATION or others.
- The information contained herein is subject to change without notice.



**PIN FUNCTION**

PIN No.	SYMBOL	FUNCTIONAL DESCRIPTION
1	V <sub>SENSE1</sub>	Amp.1 output current detection terminal
2	V <sub>OUT1</sub>	Amp.1 output terminal
3	-V <sub>IN1</sub>	Amp.1 input terminal (-)
4	+V <sub>IN1</sub>	Amp.1 input terminal (+)
5	V <sub>EE</sub>	Negative-side power supply terminal
6	+V <sub>IN2</sub>	Amp.2 input terminal (+)
7	-V <sub>IN2</sub>	Amp.2 input terminal (-)
8	V <sub>OUT2</sub>	Amp.2 output terminal
9	V <sub>SENSE2</sub>	Amp.2 output current detection terminal
10	V <sub>CC</sub>	Positive-side power supply terminal

**MAXIMUM RATINGS (Ta = 25°C)**

CHARACTERISTIC	SYMBOL	RATING	UNIT
Supply Voltage	V <sub>CC</sub> , V <sub>EE</sub>	± 18	V
Output Current	I <sub>O</sub> (PEAK)	1.2 (Note)	A
Power Dissipation	P <sub>D</sub>	12.5	W
Operating Temperature	T <sub>opr</sub>	- 30~75	°C
Storage Temperature	T <sub>stg</sub>	- 55~150	°C

(Note) See V<sub>CC</sub>-I<sub>O</sub> (AVE) MAX. Characteristics  
T<sub>c</sub> = 25°C

**ELECTRICAL CHARACTERISTICS (Unless otherwise specified, V<sub>CC</sub> = 15V, V<sub>EE</sub> = - 15V, Ta = 25°C)**

CHARACTERISTIC		SYMBOL	TEST CIR-CUIT	TEST CONDITION	MIN.	TYP.	MAX.	UNIT
Quiescent Current		I <sub>CC</sub>	1	—	—	20	35	mA
Input Off Set Current		I <sub>IO</sub>	2	—	—	2	100	nA
Input Bias Current		I <sub>I</sub>	2	—	—	50	300	nA
Input Off Set Voltage		V <sub>IO</sub>	1	—	—	1.0	7.0	mV
Output Voltage Swing	Upper	V <sub>OH</sub>	3	V <sub>CC</sub> = ± 15V, I <sub>O</sub> = 300mA	11.5	12.1	—	V
	Lower	V <sub>OL</sub>			- 11.5	- 12.3	—	
	Upper	V <sub>OH</sub>	3	V <sub>CC</sub> = ± 6V, I <sub>O</sub> = 1A	2.2	3.3	—	V
	Lower	V <sub>OL</sub>			- 2.2	- 3.7	—	
Open Loop Gain		G <sub>VO</sub>	4	—	—	90	—	dB
Input Common Mode Voltage Range		CMR	5	—	± 13	± 14	—	V
Common Mode Rejection Ratio		CMRR	5	V <sub>IN</sub> = - 10~10V	90	95	—	dB
Supply Voltage Rejection Ratio		SVRR	5	V <sub>CC</sub> = - V <sub>EE</sub> = 6~15V ± 1V	—	45	125	μV/V
Slew Rate		SR	6	—	—	0.4	—	V/μs
Short Circuit Current		I <sub>SC</sub>	7	R <sub>SC</sub> = 0.68Ω	0.8	1.0	—	A
Cross Talk		C <sub>T</sub>	5	V <sub>IN</sub> = - 14~14V	—	60	—	dB

TEST CIRCUIT 1

$I_{CC}, V_{IO}$

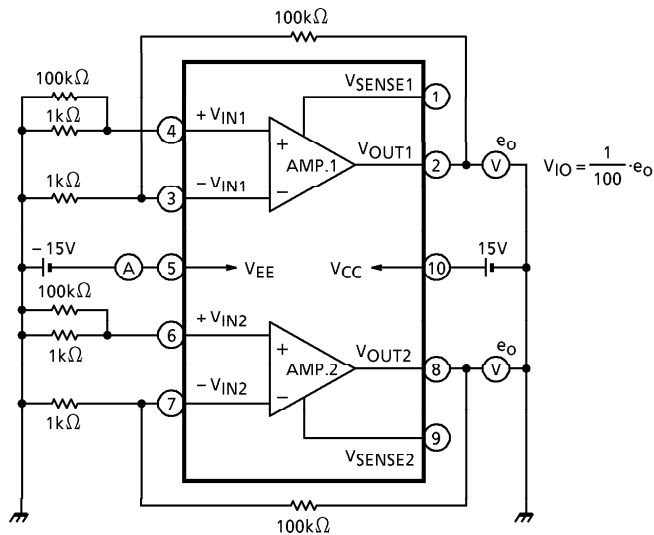

TEST CIRCUIT 2

$I_{I+}, I_{I-}, I_{IO}$

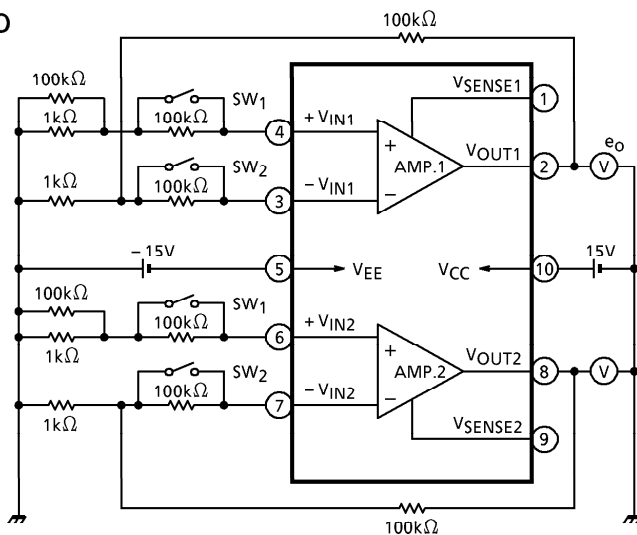

When SW<sub>1</sub> and SW<sub>2</sub> are closed, the measured value is V<sub>M1</sub>.  
 When I<sub>I+</sub> + SW<sub>1</sub> is closed and SW<sub>2</sub> is open, the measured value is V<sub>M2</sub>.  

$$I_{I+} = \frac{V_{M2} - V_{M1}}{100k} \cdot \frac{1}{100}$$
 When I<sub>I-</sub> - SW<sub>1</sub> is open and SW<sub>2</sub> is closed, the measured value is V<sub>M3</sub>.  

$$I_{I-} = \frac{V_{M3} - V_{M1}}{100k} \cdot \frac{1}{100}$$
 When I<sub>IO</sub> SW<sub>1</sub>, SW<sub>2</sub> is open, the measured value is V<sub>M4</sub>.  

$$I_{IO} = \frac{V_{M4} - V_{M1}}{100k} \cdot \frac{1}{100}$$

**TEST CIRCUIT 3**

$V_{OH}, V_{OL}$

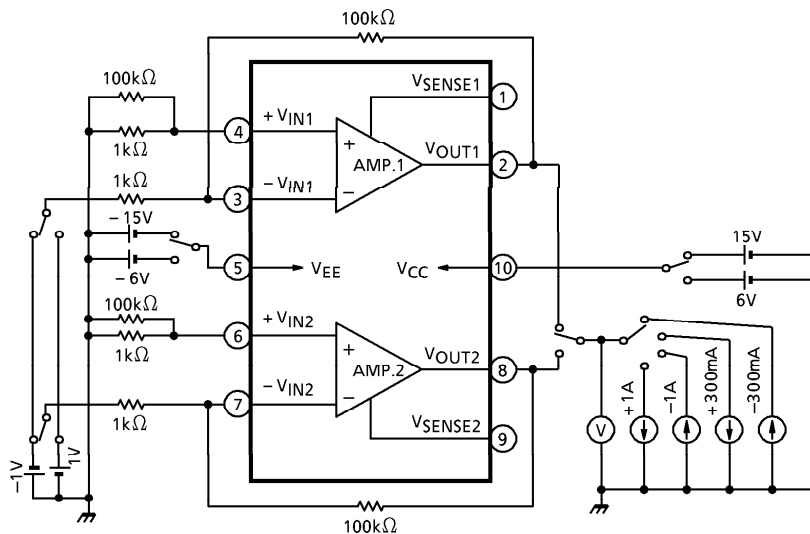

Set  $V_{CC} = -V_{EE} = 15V$ , then  $I_O = 300mA$   
 Set  $V_{CC} = -V_{EE} = 6V$ , then  $I_O = 1A$

**TEST CIRCUIT 4**

$G_{VO}$

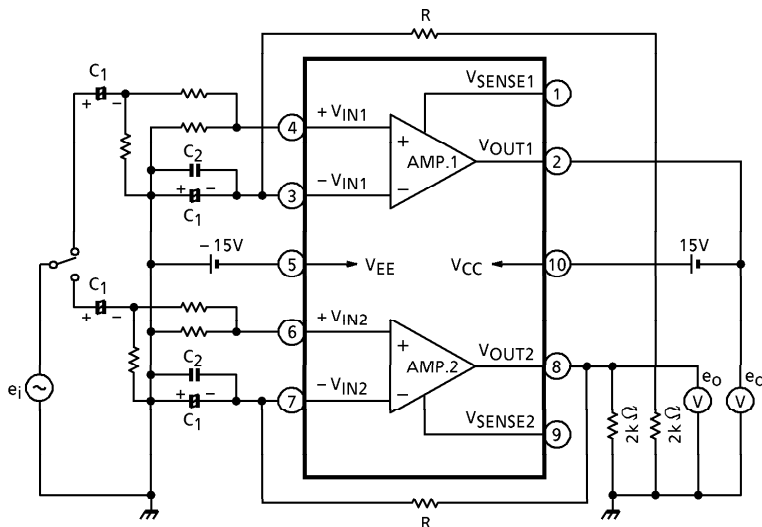

$G_{VO} = 20 \log e_o / e_i$   
 $R \gg 1/WC_1$   
 $C_1$  : obstruction direct current short-circuit  
 $C_2$  : radio frequency short-circuit.  
 Mica or Titanium capacitor use.

**TEST CIRCUIT 5**

CMR, CMRR, SVRR,  $C_T$

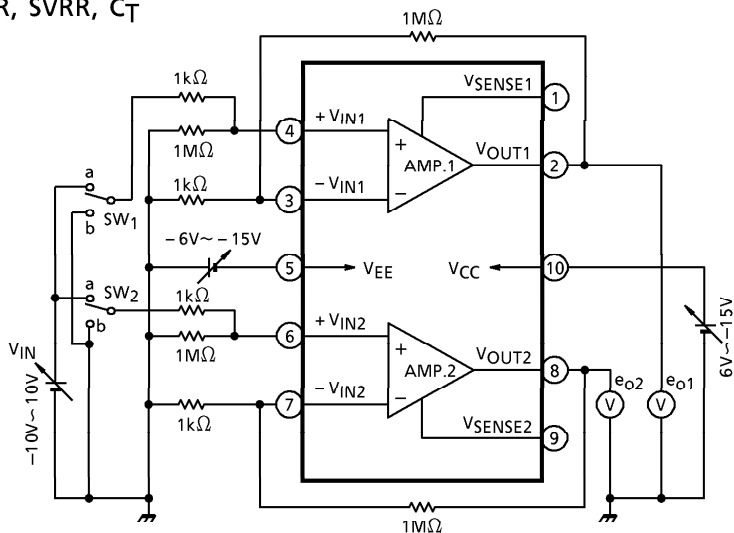

CMR :  $V_{IN}$  value where a change in  $V_{IN}$  does not cause  $e_o$  to operate.

$$CMRR = 20 \log_{10} \frac{\Delta e_o}{\Delta V_{IN}}$$

$$SVRR = 20 \log_{10} \frac{\Delta e_o}{\Delta V_{CC}} \text{ or } = 20 \log_{10} \frac{\Delta e_o}{\Delta V_{EE}} \quad (V_{IN} = 0V)$$

$$C_T = 20 \log_{10} \frac{\Delta e_{o1}}{\Delta V_{IN}} \text{ (SW}_1 : b, \text{ SW}_2 : a) \text{ or } = 20 \log_{10} \frac{\Delta e_{o2}}{\Delta V_{IN}} \text{ (SW}_1 : a, \text{ SW}_2 : b)$$

**TEST CIRCUIT 6**

SR

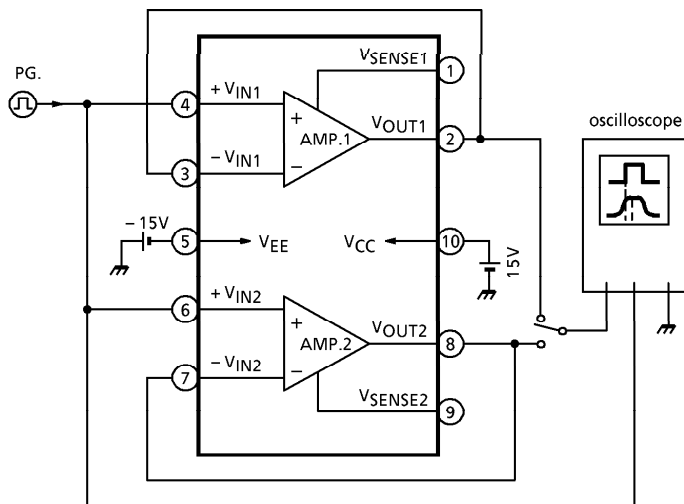

TEST CIRCUIT 7

I<sub>SC</sub>

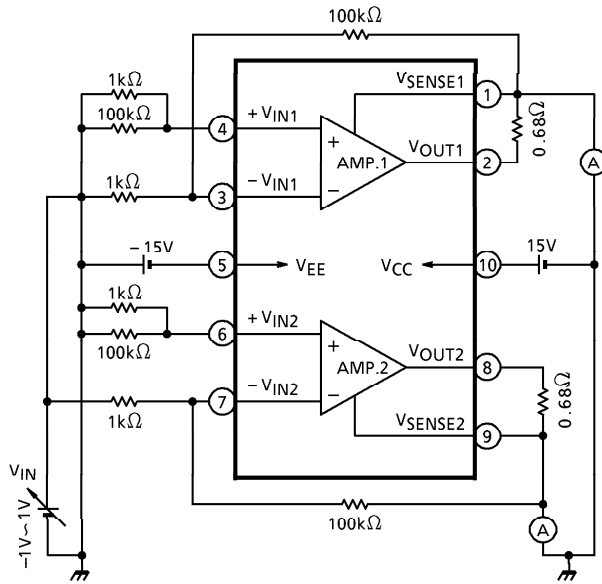

$$I_{SC} = V_M / 0.68\Omega$$

V<sub>M</sub> : V<sub>IN</sub> detection resistance voltage when a change in V<sub>IN</sub> triggers the current delimiter.

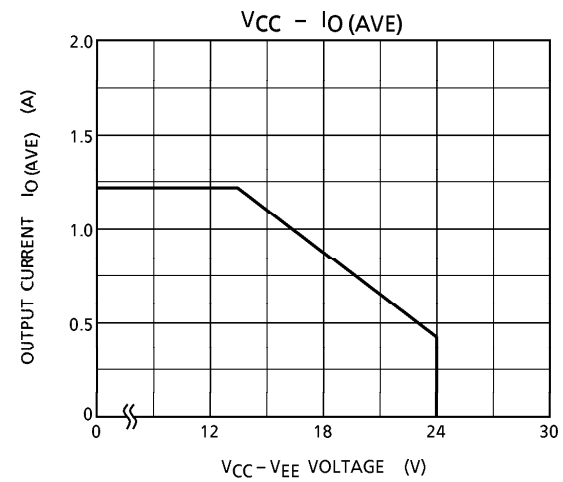
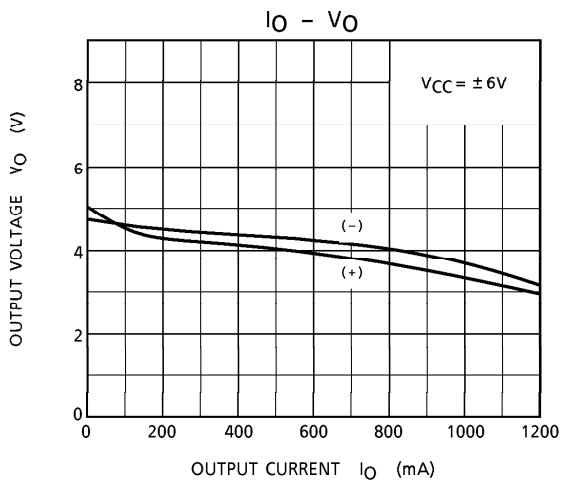
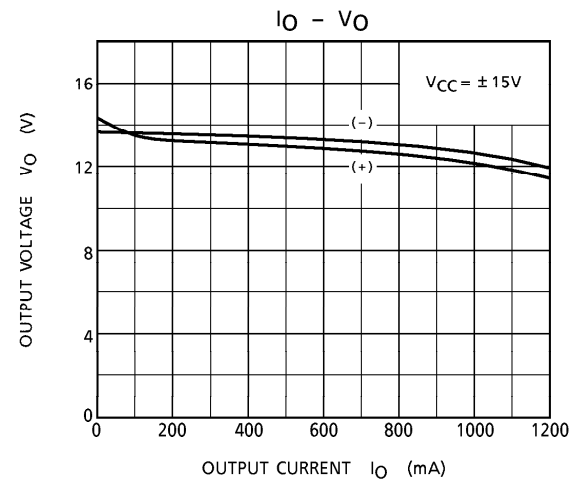
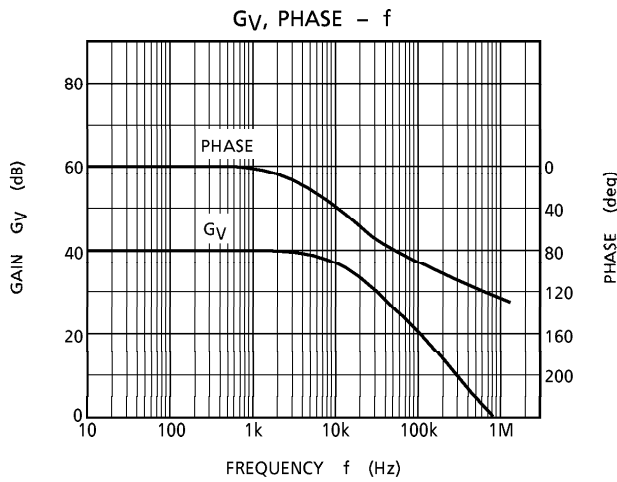
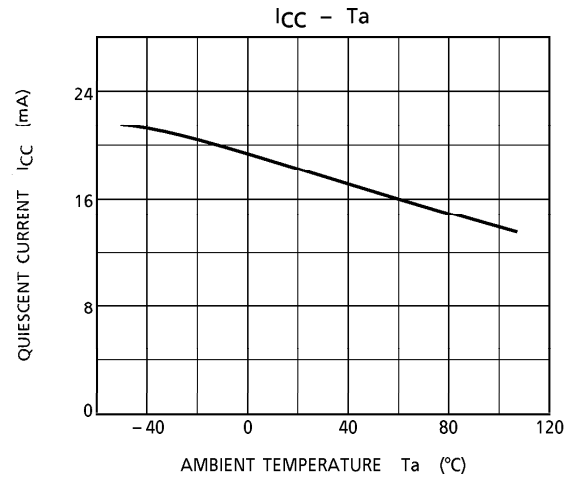
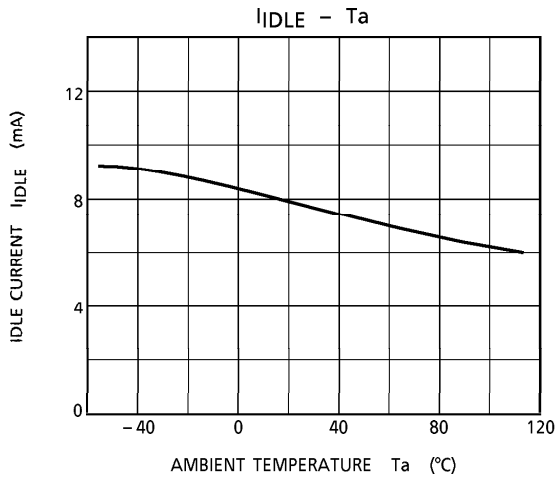

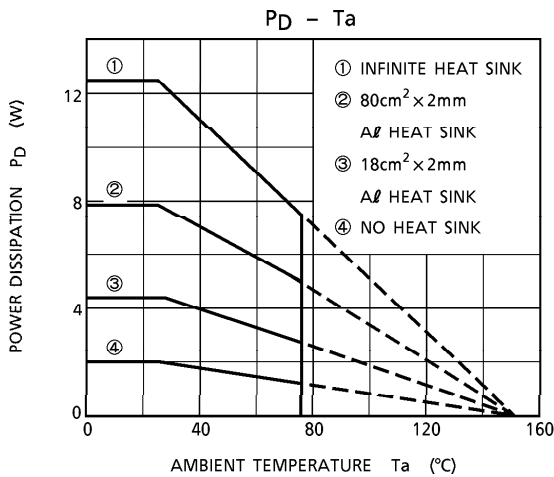

**APPLICATION CIRCUIT 1**

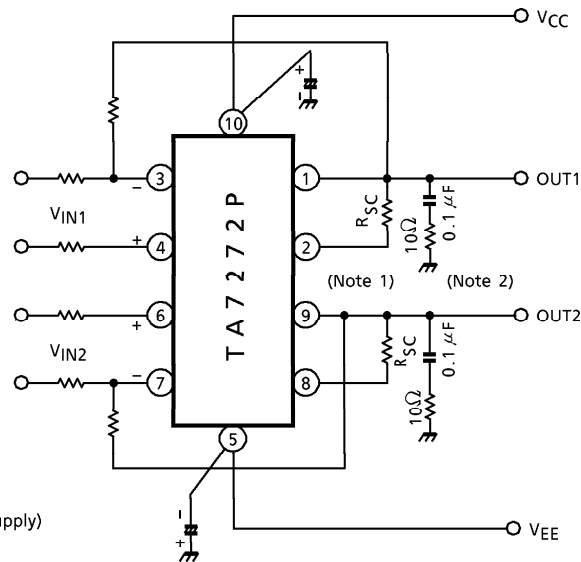

(Note 1)  $I_{SC} \doteq \frac{0.7 (V)}{R_{SC} (\Omega)} (A)$

(Note 2) When crossover distortion becomes, noticeable at frequencies higher than 80kHz, change the value of the capacitor, which functions as a compensating circuit, to about 0.33 $\mu$ F, In this case, resistor is not needed.

**APPLICATION CIRCUIT 2 (Actuator)**

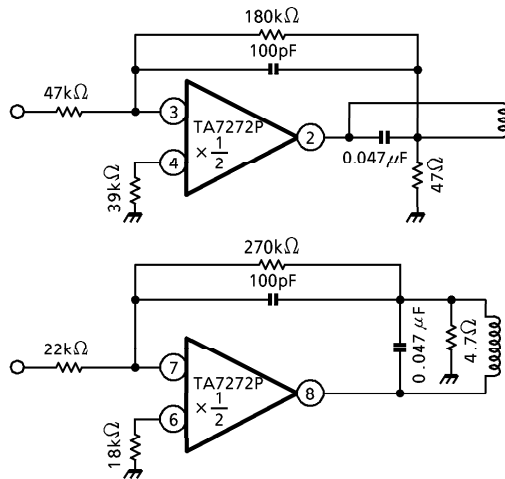

**APPLICATION CIRCUIT 3 (Speed and carriage control)**

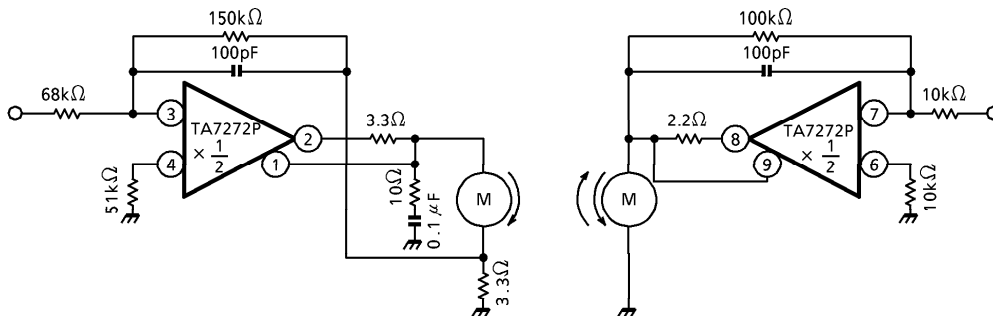

(Note) Utmost care is necessary in the design of the output line, V<sub>CC</sub>, V<sub>EE</sub> and GND line since IC may be destroyed due to short-circuit between outputs, air contamination fault, or fault by improper grounding.

OUTLINE DRAWING  
HSIP10-P-2.54

Unit : mm

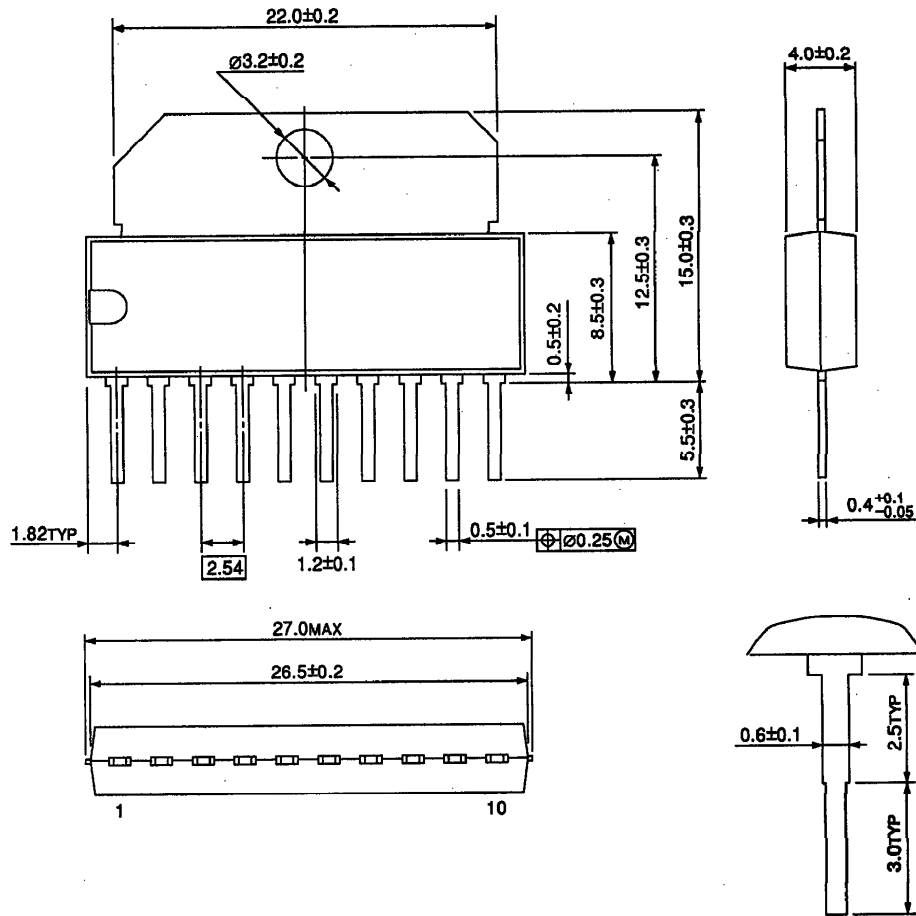

Weight : 2.47g (Typ.)