

INTEGRATED CIRCUITS

DATA SHEET

UAA2077BM

2 GHz image rejecting front-end

Product specification

1995 Dec 13

Supersedes data of July 1995

File under Integrated Circuits, IC03

2 GHz image rejecting front-end

UAA2077BM

FEATURES

- Low-noise, wide dynamic range amplifier
- Very low noise figure
- Dual balanced mixer for over 25 dB on-chip image rejection
- IF I/Q combiner at 188 MHz
- On-chip quadrature network
- Down-conversion mixer for closed-loop transmitters
- Independent TX/RX fast ON/OFF power-down modes
- Very small outline packaging
- Very small application (no image filter).

APPLICATIONS

- 1800 MHz front-end for DCS1800 hand-portable equipment
- Compact digital mobile communication equipment
- TDMA receivers e.g. PCS and RF-LANS.

GENERAL DESCRIPTION

UAA2077BM contains both a receiver front-end and a high frequency transmit mixer intended to be used in mobile telephones. Designed in an advanced BiCMOS process it combines high performance with low power consumption and a high degree of integration, thus reducing external component costs and total front-end size.

The main advantage of the UAA2077BM is its ability to provide over 25 dB of image rejection. Consequently, the image filter between the LNA and the mixer is suppressed.

Image rejection is achieved in the internal architecture by two RF mixers in quadrature and two all-pass filters in I and Q IF channels that phase shift the IF by 45° and 135° respectively. The two phase shifted IFs are recombined and buffered to furnish the IF output signal.

For instance, signals presented at the RF input at the LO + IF frequency are rejected through this signal processing while signals at the LO – IF frequency can form the IF signal. An internal switch enables the upper or lower image frequency to be rejected.

The receiver section consists of a low-noise amplifier that drives a quadrature mixer pair. The IF amplifier has on-chip 45° and 135° phase shifting and a combining network for image rejection. The IF driver has differential open-collector type outputs.

The LO part consists of an internal all-pass type phase shifter to provide quadrature LO signals to the receive mixers. The centre frequency of the phase shifter is adjustable for maximum image rejection in a given band. The all-pass filters outputs are buffered before being fed to the receive mixers.

The transmit section consists of a low-noise amplifier and a down-conversion mixer. In the transmit mode an internal LO buffer is used to drive the transmit IF down-conversion mixer.

All RF and IF inputs or outputs are balanced.

Pins RXON, TXON and SXON enable a selection to be made of whether to reject the upper or lower image frequency and control of the different power-down modes. Special care has been taken for fast power-up switching.

QUICK REFERENCE DATA

SYMBOL	PARAMETER	MIN.	TYP.	MAX.	UNIT
V _{CC}	supply voltage	3.6	4.0	5.3	V
I _{CC(RX)}	receive supply current	21.5	26.5	33.5	mA
I _{CC(TX)}	transmit supply current	10.5	13.5	18	mA
I _{CC(PD)}	supply current in power-down	–	–	50	µA
T _{amb}	operating ambient temperature	–30	+25	+85	°C

ORDERING INFORMATION

TYPE NUMBER	PACKAGE		
	NAME	DESCRIPTION	VERSION
UAA2077BM	SSOP20	plastic shrink small outline package; 20 leads; body width 4.4 mm	SOT266-1

2 GHz image rejecting front-end

UAA2077BM

BLOCK DIAGRAM

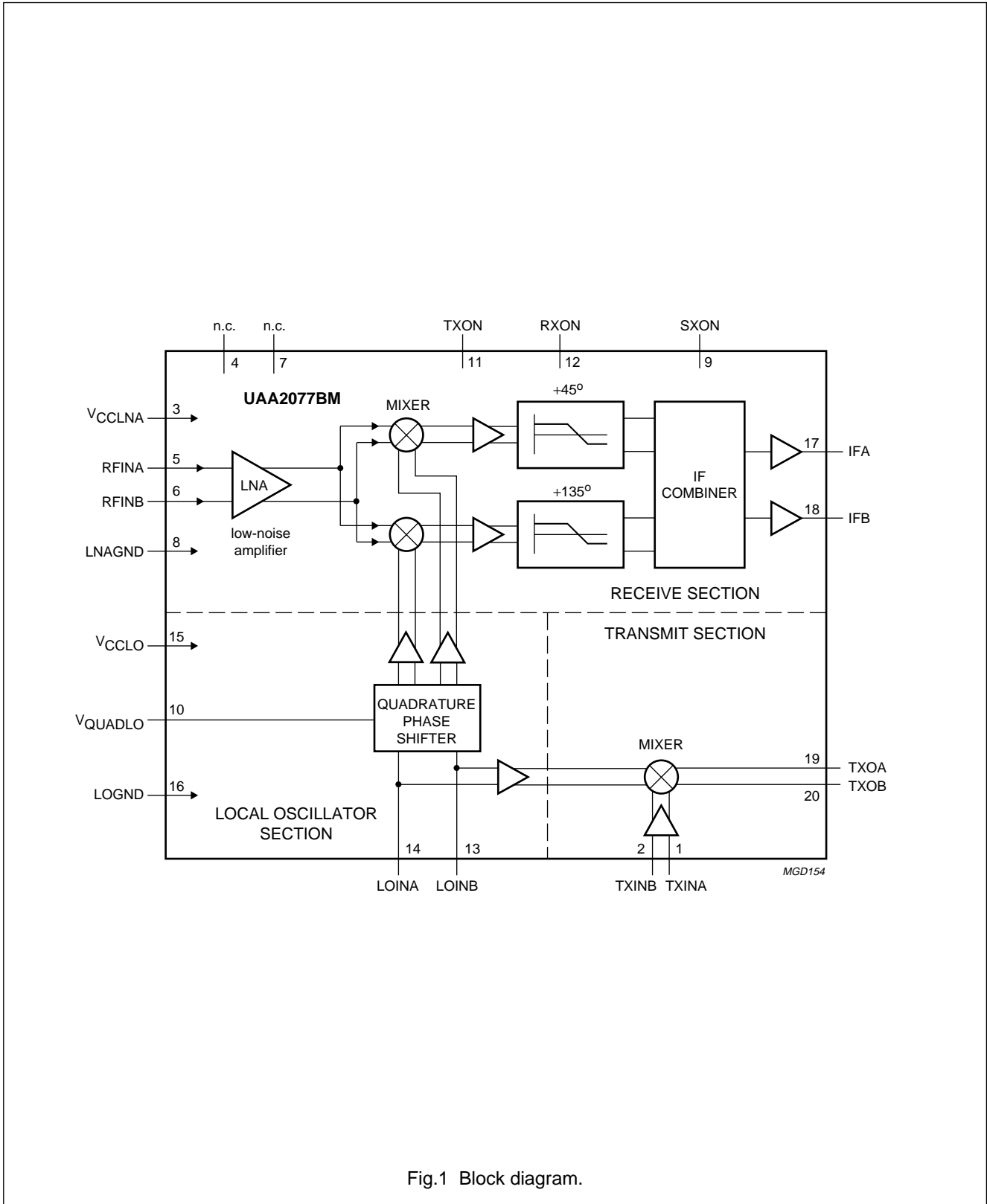

Fig.1 Block diagram.

2 GHz image rejecting front-end

UAA2077BM

PINNING

SYMBOL	PIN	DESCRIPTION
TXINA	1	transmit mixer input A (balanced)
TXINB	2	transmit mixer input B (balanced)
V _{CCLNA}	3	supply voltage for LNA, IF parts and TX mixer
n.c.	4	not connected
RFINA	5	RF input A (balanced)
RFINB	6	RF input B (balanced)
n.c.	7	not connected
LNAGND	8	ground for LNA, IF parts and TX mixer
SXON	9	SX mode enable (see Table 1)
V _{QUADLO}	10	input voltage for LO quadrature trimming
TXON	11	TX mode enable (see Table 1)
RXON	12	RX mode enable (see Table 1)
LOINB	13	LO input B (balanced)
LOINA	14	LO input A (balanced)
V _{CCLO}	15	supply voltage for LO parts
LOGND	16	ground for LO parts
IFA	17	IF output A (balanced)
IFB	18	IF output B (balanced)
TXOA	19	transmit mixer IF output A (balanced)
TXOB	20	transmit mixer IF output B (balanced)

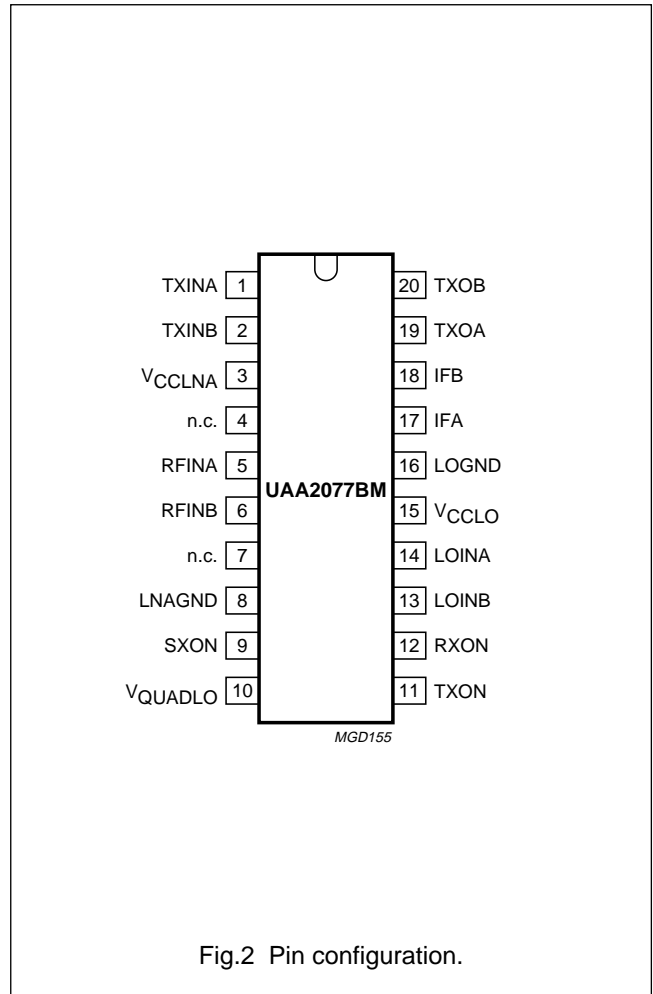

Fig.2 Pin configuration.

2 GHz image rejecting front-end

UAA2077BM

FUNCTIONAL DESCRIPTION

Receive section

The circuit contains a low-noise amplifier followed by two high dynamic range mixers. These mixers are of the Gilbert-cell type, the whole internal architecture is fully differential.

The local oscillator, shifted in phase to 45° and 135°, mixes the amplified RF to create I and Q channels. The two I and Q channels are buffered, phase shifted by 45° and 135° respectively, amplified and recombined internally to realize the image rejection.

Balanced signal interfaces are used for minimizing crosstalk due to package parasitics.

The IF output is differential and of the open-collector type. Typical application will load the output with a differential 1 kΩ load; for example, a 1 kΩ resistor load at each IF output, plus a differential 2 kΩ load consisting of the input impedance of the IF filter or the input impedance of the matching network for the IF filter. The power gain refers to the available power on this 2 kΩ load. The path to V_{CC} for the DC current should be achieved via tuning inductors. The output voltage is limited to V_{CC} + 3V_{be} or 3 diode forward voltage drops.

Fast switching, ON/OFF, of the receive section is controlled by the hardware input RXON.

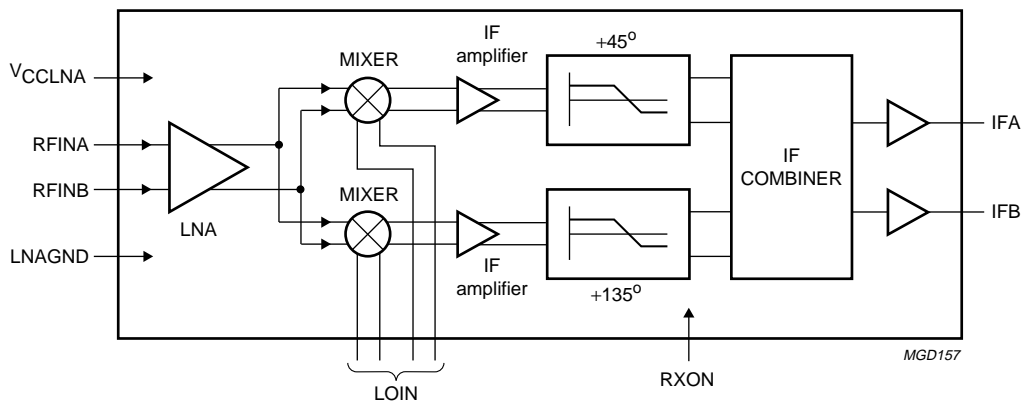

Fig.3 Block diagram, receive section.

2 GHz image rejecting front-end

UAA2077BM

Local oscillator section

The local oscillator (LO) input directly drives the two internal all-pass networks to provide quadrature LO to the receive mixers.

The centre frequency of the receive band is adjustable by the voltage on pin V_{QUADLO} . This should be achieved by connecting a resistor between V_{QUADLO} and V_{CC} . Over 25 dB of image rejection can be obtained by an optimum resistor value.

A synthesizer-ON mode (SX mode) is used to power-up all LO input buffers, thus minimizing the pulling effect on the external VCO when entering the receive or transmit mode. This mode is active when $SXON = 1$.

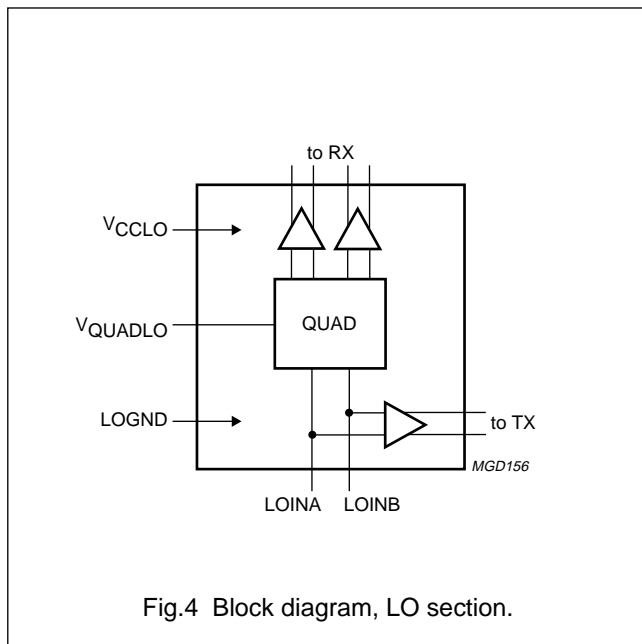

Transmit mixer

This mixer is used for down-conversion to the transmit IF. Its inputs are coupled to the transmit RF which is down-converted to a modulated transmit IF frequency, phase-locked with the baseband modulation.

The IF outputs are high-impedance (open-collector type). Typical application will load the output with a differential 500 Ω load; for example, a 500 Ω resistor load, connected to V_{CC} for DC path, at each TX output, plus a differential 1 kΩ consisting of the input impedance of the matching network for the following TX part. The mixer can also be used for frequency up-conversion.

Fast switching ON/OFF, of the transmit section is controlled by the hardware input TXON.

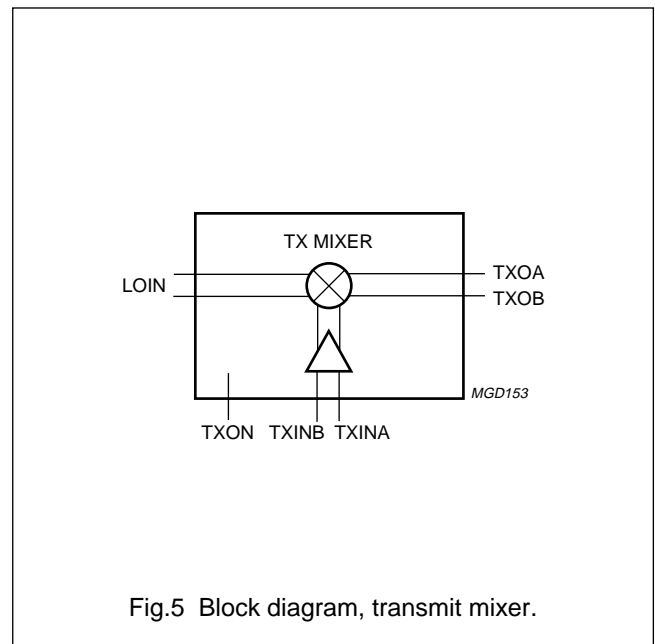

Table 1 Control of power status

EXTERNAL PIN LEVEL			CIRCUIT MODE OF OPERATION
TXON	RXON	SXON	
LOW	LOW	LOW	power-down mode
LOW	HIGH	LOW	RX mode, $f_{LO} < f_{RF}$: receive section and LO buffers to RX on
HIGH	LOW	LOW	TX mode: transmit section and LO buffers to TX on
LOW	LOW	HIGH	SX mode: complete LO section on
LOW	HIGH	HIGH	SRX mode, $f_{LO} < f_{RF}$: receive section on and SX mode active
HIGH	LOW	HIGH	STX mode: transmit section on and SX mode active
HIGH	HIGH	LOW	RX mode, $f_{LO} > f_{RF}$: receive section and LO buffers to RX on
HIGH	HIGH	HIGH	SRX mode, $f_{LO} > f_{RF}$: receive section on and SX mode active

2 GHz image rejecting front-end

UAA2077BM

LIMITING VALUES

In accordance with the Absolute Maximum Rating System (IEC 134).

SYMBOL	PARAMETER	MIN.	MAX.	UNIT
V_{CC}	supply voltage	–	9.0	V
ΔGND	difference in ground supply voltage applied between LOGND and LNAGND	–	0.6	V
$P_{i(max)}$	maximum power input	–	+20	dBm
$T_{j(max)}$	maximum operating junction temperature	–	+150	°C
$P_{dis(max)}$	maximum power dissipation in quiet air	–	250	mW
T_{stg}	storage temperature	–65	+150	°C

THERMAL CHARACTERISTICS

SYMBOL	PARAMETER	VALUE	UNIT
$R_{th\ j-a}$	thermal resistance from junction to ambient in free air	120	K/W

HANDLING

All pins withstand the ESD test in accordance with MIL-STD-883C class 2 (method 3015.5), except pins LOINA and LOINB which withstand 1500 V (class 1).

2 GHz image rejecting front-end

UAA2077BM

DC CHARACTERISTICS

$V_{CC} = 4\text{ V}$; $T_{amb} = 25\text{ }^{\circ}\text{C}$; unless otherwise specified.

SYMBOL	PARAMETER	CONDITIONS	MIN.	TYP.	MAX.	UNIT
Pins: V_{CCLNA} and V_{CCLO}						
V_{CC}	supply voltage	over full temperature range	3.6	4.0	5.3	V
$I_{CC(RX)}$	supply current in RX mode		21.5	26.5	33.5	mA
$I_{CC(TX)}$	supply current in TX mode		10.5	13.5	18	mA
$I_{CC(PD)}$	supply current in power-down mode		–	–	50	μA
$I_{CC(SX)}$	supply current in SX mode		5.5	7.5	10	mA
$I_{CC(SRX)}$	supply current in SRX mode		–	29	–	mA
$I_{CC(STX)}$	supply current in STX mode		–	18	–	mA
Pins: RXON, TXON and SXON						
V_{th}	CMOS threshold voltage	note 1	–	1.25	–	V
V_{IH}	HIGH level input voltage		$0.7V_{CC}$	–	V_{CC}	V
V_{IL}	LOW level input voltage		–0.3	–	0.8	V
I_{IH}	HIGH level static input current	pins at $V_{CC} - 0.4\text{ V}$	–1	–	+1	μA
I_{IL}	LOW level static input current	pins at 0.4 V	–1	–	+1	μA
Pins: RFINA and RFINB						
V_I	DC input voltage level	receive section on	–	2.0	–	V
Pins: IFA and IFB						
I_O	DC output current	receive section on	–	2.5	–	mA
Pins: TXINA and TXINB						
V_I	DC input voltage level	transmit section on	–	2.0	–	V
Pins: TXOA and TXOB						
I_O	DC output current	transmit section on	–	0.9	–	mA
Pins: LOINA and LOINB						
V_{LOIN}	DC input voltage level	RXON, TXON or SXON HIGH	–	3.3	–	V

Note

1. The referenced inputs should be connected to a valid CMOS input level.

2 GHz image rejecting front-end

UAA2077BM

AC CHARACTERISTICS

$V_{CC} = 4\text{ V}$; $T_{amb} = -30\text{ to }+85\text{ }^{\circ}\text{C}$; unless otherwise specified.

SYMBOL	PARAMETER	CONDITIONS	MIN.	TYP.	MAX.	UNIT
Receive section (receive section enabled)						
R_{iRX}	RF input resistance (real part of the parallel input impedance)	balanced; at 1850 MHz	–	60	–	Ω
C_{iRX}	RF input capacitance (imaginary part of the parallel input impedance)	balanced; at 1850 MHz	–	1	–	pF
f_{iRX}	RF input frequency		1800	–	2000	MHz
RL_{iRX}	return loss on matched RF input	balanced; note 1	11	15	–	dB
G_{CPRX}	conversion power gain	differential RF inputs to differential IF outputs loaded to 1 k Ω differential	17	20	23	dB
G_{rip}	gain ripple as a function of RF frequency	between 1805 and 1880 MHz; note 2	–	0.2	–	dB
$\Delta G/T$	gain variation with temperature	$T_{amb} = -30\text{ to }+25\text{ }^{\circ}\text{C}$; note 2	–20	0	+10	mdB/ $^{\circ}\text{C}$
		$T_{amb} = +25\text{ to }+85\text{ }^{\circ}\text{C}$; note 2	–40	–30	–20	mdB/ $^{\circ}\text{C}$
$CP1_{RX}$	1 dB compression point	differential RF inputs to differential IF outputs; note 1	–26	–23	–	dBm
DES3	3 dB desensitisation point	interferer frequency offset: 3 MHz; differential RF inputs to differential IF outputs; note 1	–	–30	–	dBm
		interferer frequency offset: 20 MHz; differential RF inputs to differential IF outputs; note 1	–	–27	–	dBm
$IP2D_{RX}$	2nd-order intercept point	differential RF inputs to differential IF outputs; note 2	+15	+22	–	dBm
$IP3_{RX}$	3rd-order intercept point	differential RF inputs to differential IF outputs; note 2	–23	–17	–	dBm
NF_{RX}	overall noise figure	differential RF inputs to differential IF outputs; notes 2 and 3	–	4.3	5.0	dB
Z_{LRX}	typical application IF output load impedance	balanced	–	1	–	k Ω
RL_{iRX}	return loss on matched IF input	balanced; note 1	11	15	–	dB
f_{oRX}	IF frequency range		170	188	210	MHz
IR_{RX}	rejection of image frequency	V_{QUADLO} tuned	20	–	–	dB
		$f_{LO} < f_{RF}$; $f_{IF} = 188\text{ MHz}$; note 4	25	32	–	dB
Local oscillator section (receive section enabled)						
f_{iLO}	LO input frequency		1600	–	2200	MHz
R_{iLO}	LO input resistance (real part of the parallel input impedance)	balanced	–	45	–	Ω
C_{iLO}	LO input capacitance (imaginary part of the parallel input impedance)	balanced	–	2	–	pF

2 GHz image rejecting front-end

UAA2077BM

SYMBOL	PARAMETER	CONDITIONS	MIN.	TYP.	MAX.	UNIT
RL _{iLO}	return loss on matched input (including standby mode)	note 1	9	12	–	dB
ΔRL _{iLO}	return loss variation between SX, SRX and STX modes	linear S ₁₁ variation; note 1	–	5	–	mU
P _{iLO}	LO input power level		–6	–3	+3	dBm
RI _{LO}	reverse isolation	LOIN to RFIN at LO frequency; note 1	40	–	–	dB
R _{tune}	image rejection tuning resistor	connected between V _{QUADLO} and V _{CC}	0	4.7	–	kΩ
Transmit section (transmit section enabled)						
Z _{LTX}	TX IF typical load impedance	balanced	–	500	–	Ω
RL _{oTX}	return loss on matched TX IF output	note 1	11	15	–	dB
R _{iTX}	TX RF input resistance (real part of the parallel input impedance)	balanced; at 1750 MHz	–	65	–	Ω
C _{iTX}	TX RF input capacitance (imaginary part of the parallel input impedance)	balanced; at 1750 MHz	–	1	–	pF
f _{iTX}	TX input frequency		1600	–	2000	MHz
RL _{iTX}	return loss on matched TX input	note 1	10	15	–	dB
G _{CPTX}	conversion power gain	differential transmitter inputs to differential transmitter IF outputs loaded with 500 Ω differential	6	9	12	dB
f _{oTX}	TX output frequency		50	–	400	MHz
CP1 _{TX}	1 dB input compression point	note 2	–25	–22	–	dBm
IP2 _{TX}	2nd-order intercept point	note 2	–	+22	–	dBm
IP3 _{TX}	3rd-order intercept point	note 2	–20	–16	–	dBm
NF _{TX}	noise figure	double sideband; notes 2 and 3	–	5	9	dB
I _{TX}	isolation	LOIN to TXIN; note 1	40	–	–	dB
RI _{TX}	reverse isolation	TXIN to LOIN; note 1	40	–	–	dB
Timing						
t _{stu}	start-up time of each block		1	5	20	μs

Notes

1. Measured and guaranteed only on UAA2077BM demonstration board at T_{amb} = +25 °C.
2. Measured and guaranteed only on UAA2077BM demonstration board.
3. This value includes printed-circuit board and balun losses.
4. Measured and guaranteed only on UAA2077BM demonstration board at T_{amb} = +25 °C, with a 4.7 kΩ resistor connected between V_{QUADLO} and V_{CC}.

2 GHz image rejecting front-end

UAA2077BM

APPLICATION INFORMATION

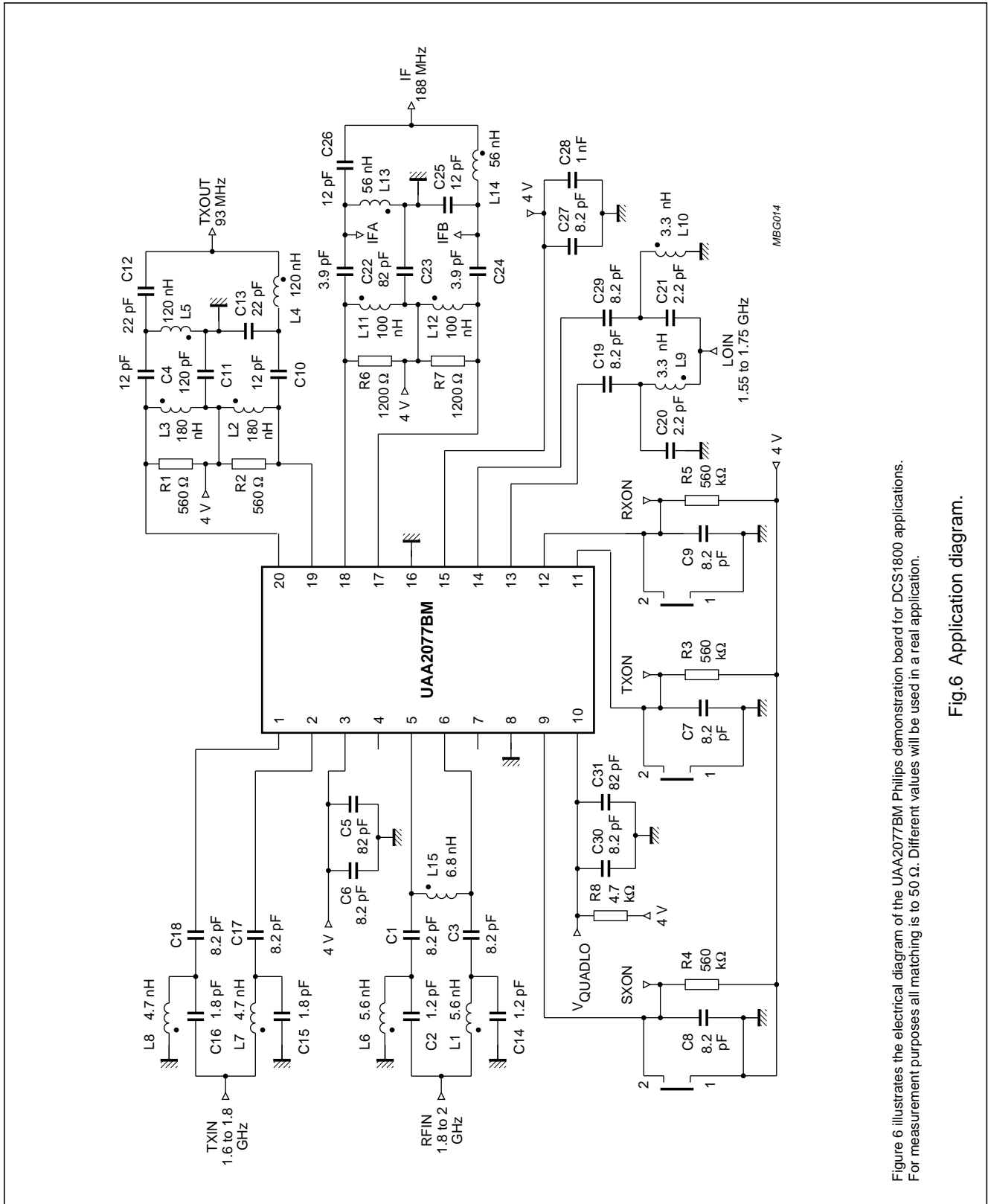

Figure 6 illustrates the electrical diagram of the UAA2077BM Philips demonstration board for DCS1800 applications. For measurement purposes all matching is to 50 Ω. Different values will be used in a real application.

Fig.6 Application diagram.

2 GHz image rejecting front-end

UAA2077BM

PACKAGE OUTLINE

SSOP20: plastic shrink small outline package; 20 leads; body width 4.4 mm

SOT266-1

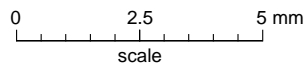
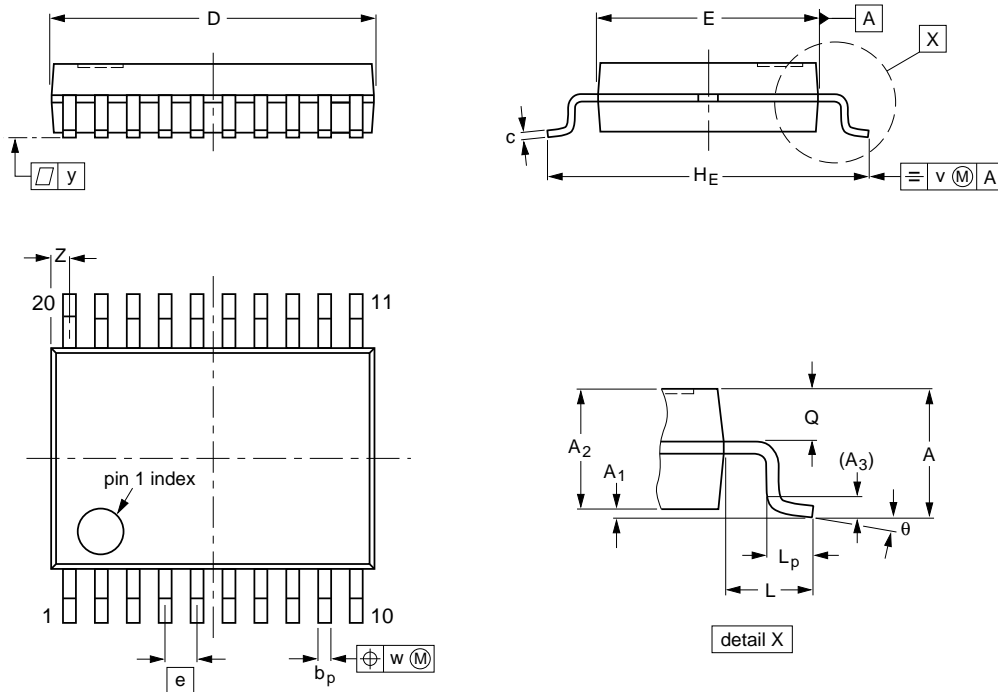

DIMENSIONS (mm are the original dimensions)

UNIT	A max.	A ₁	A ₂	A ₃	b _p	c	D ⁽¹⁾	E ⁽¹⁾	e	H _E	L	L _p	Q	v	w	y	Z ⁽¹⁾	θ
mm	1.5	0.15 0	1.4 1.2	0.25	0.32 0.20	0.20 0.13	6.6 6.4	4.5 4.3	0.65	6.6 6.2	1.0	0.75 0.45	0.65 0.45	0.2	0.13	0.1	0.48 0.18	10° 0°

Note

1. Plastic or metal protrusions of 0.20 mm maximum per side are not included.

OUTLINE VERSION	REFERENCES				EUROPEAN PROJECTION	ISSUE DATE
	IEC	JEDEC	EIAJ			
SOT266-1						90-04-05 95-02-25

2 GHz image rejecting front-end

UAA2077BM

SOLDERING

Introduction

There is no soldering method that is ideal for all IC packages. Wave soldering is often preferred when through-hole and surface mounted components are mixed on one printed-circuit board. However, wave soldering is not always suitable for surface mounted ICs, or for printed-circuits with high population densities. In these situations reflow soldering is often used.

This text gives a very brief insight to a complex technology. A more in-depth account of soldering ICs can be found in our *"IC Package Databook"* (order code 9398 652 90011).

Reflow soldering

Reflow soldering techniques are suitable for all SSOP packages.

Reflow soldering requires solder paste (a suspension of fine solder particles, flux and binding agent) to be applied to the printed-circuit board by screen printing, stencilling or pressure-syringe dispensing before package placement.

Several techniques exist for reflowing; for example, thermal conduction by heated belt. Dwell times vary between 50 and 300 seconds depending on heating method. Typical reflow temperatures range from 215 to 250 °C.

Preheating is necessary to dry the paste and evaporate the binding agent. Preheating duration: 45 minutes at 45 °C.

Wave soldering

Wave soldering is **not** recommended for SSOP packages. This is because of the likelihood of solder bridging due to closely-spaced leads and the possibility of incomplete solder penetration in multi-lead devices.

If wave soldering cannot be avoided, the following conditions must be observed:

- **A double-wave (a turbulent wave with high upward pressure followed by a smooth laminar wave) soldering technique should be used.**
- **The longitudinal axis of the package footprint must be parallel to the solder flow and must incorporate solder thieves at the downstream end.**

Even with these conditions, only consider wave soldering SSOP packages that have a body width of 4.4 mm, that is SSOP16 (SOT369-1) or SSOP20 (SOT266-1).

During placement and before soldering, the package must be fixed with a droplet of adhesive. The adhesive can be applied by screen printing, pin transfer or syringe dispensing. The package can be soldered after the adhesive is cured.

Maximum permissible solder temperature is 260 °C, and maximum duration of package immersion in solder is 10 seconds, if cooled to less than 150 °C within 6 seconds. Typical dwell time is 4 seconds at 250 °C.

A mildly-activated flux will eliminate the need for removal of corrosive residues in most applications.

Repairing soldered joints

Fix the component by first soldering two diagonally-opposite end leads. Use only a low voltage soldering iron (less than 24 V) applied to the flat part of the lead. Contact time must be limited to 10 seconds at up to 300 °C. When using a dedicated tool, all other leads can be soldered in one operation within 2 to 5 seconds between 270 and 320 °C.

2 GHz image rejecting front-end

UAA2077BM

DEFINITIONS

Data sheet status	
Objective specification	This data sheet contains target or goal specifications for product development.
Preliminary specification	This data sheet contains preliminary data; supplementary data may be published later.
Product specification	This data sheet contains final product specifications.
Limiting values	
Limiting values given are in accordance with the Absolute Maximum Rating System (IEC 134). Stress above one or more of the limiting values may cause permanent damage to the device. These are stress ratings only and operation of the device at these or at any other conditions above those given in the Characteristics sections of the specification is not implied. Exposure to limiting values for extended periods may affect device reliability.	
Application information	
Where application information is given, it is advisory and does not form part of the specification.	

LIFE SUPPORT APPLICATIONS

These products are not designed for use in life support appliances, devices, or systems where malfunction of these products can reasonably be expected to result in personal injury. Philips customers using or selling these products for use in such applications do so at their own risk and agree to fully indemnify Philips for any damages resulting from such improper use or sale.

2 GHz image rejecting front-end

UAA2077BM

NOTES

Philips Semiconductors – a worldwide company

Argentina: IEROD, Av. Juramento 1992 - 14.b, (1428)
BUENOS AIRES, Tel. (541)786 7633, Fax. (541)786 9367

Australia: 34 Waterloo Road, NORTH RYDE, NSW 2113,
Tel. (02)805 4455, Fax. (02)805 4466

Austria: Triester Str. 64, A-1101 WIEN, P.O. Box 213,
Tel. (01)60 101-1236, Fax. (01)60 101-1211

Belgium: Postbus 90050, 5600 PB EINDHOVEN, The Netherlands,
Tel. (31)40-2783749, Fax. (31)40-2788399

Brazil: Rua do Rocio 220 - 5th floor, Suite 51,
CEP: 04552-903-SÃO PAULO-SP, Brazil,
P.O. Box 7383 (01064-970),
Tel. (011)821-2333, Fax. (011)829-1849

Canada: PHILIPS SEMICONDUCTORS/COMPONENTS:
Tel. (800) 234-7381, Fax. (708) 296-8556

Chile: Av. Santa Maria 0760, SANTIAGO,
Tel. (02)773 816, Fax. (02)777 6730

China/Hong Kong: 501 Hong Kong Industrial Technology Centre,
72 Tat Chee Avenue, Kowloon Tong, HONG KONG,
Tel. (852)2319 7888, Fax. (852)2319 7700

Colombia: IPRELENTO LTDA, Carrera 21 No. 56-17,
77621 BOGOTA, Tel. (571)249 7624/(571)217 4609,
Fax. (571)217 4549

Denmark: Prags Boulevard 80, PB 1919, DK-2300
COPENHAGEN S, Tel. (45)32 88 26 36, Fax. (45)31 57 19 49

Finland: Sinikalliontie 3, FIN-02630 ESPOO,
Tel. (358)0-615 800, Fax. (358)0-61580 920

France: 4 Rue du Port-aux-Vins, BP317,
92156 SURESNES Cedex,
Tel. (01)4099 6161, Fax. (01)4099 6427

Germany: P.O. Box 10 51 40, 20035 HAMBURG,
Tel. (040)23 53 60, Fax. (040)23 53 63 00

Greece: No. 15, 25th March Street, GR 17778 TAVROS,
Tel. (01)4894 339/4894 911, Fax. (01)4814 240

India: Philips INDIA Ltd, Shivsagar Estate, A Block,
Dr. Annie Besant Rd. Worli, Bombay 400 018
Tel. (022)4938 541, Fax. (022)4938 722

Indonesia: Philips House, Jalan H.R. Rasuna Said Kav. 3-4,
P.O. Box 4252, JAKARTA 12950,
Tel. (021)5201 122, Fax. (021)5205 189

Ireland: Newstead, Clonskeagh, DUBLIN 14,
Tel. (01)7640 000, Fax. (01)7640 200

Italy: PHILIPS SEMICONDUCTORS S.r.l.,
Piazza IV Novembre 3, 20124 MILANO,
Tel. (0039)2 6752 2531, Fax. (0039)2 6752 2557

Japan: Philips Bldg 13-37, Kohnan2-chome, Minato-ku, TOKYO 108,
Tel. (03)3740 5130, Fax. (03)3740 5077

Korea: Philips House, 260-199 Itaewon-dong,
Yongsan-ku, SEOUL, Tel. (02)709-1412, Fax. (02)709-1415

Malaysia: No. 76 Jalan Universiti, 46200 PETALING JAYA,
SELANGOR, Tel. (03)750 5214, Fax. (03)757 4880

Mexico: 5900 Gateway East, Suite 200, EL PASO, TX 79905,
Tel. 9-5(800)234-7381, Fax. (708)296-8556

Netherlands: Postbus 90050, 5600 PB EINDHOVEN, Bldg. VB,
Tel. (040)2783749, Fax. (040)2788399

New Zealand: 2 Wagener Place, C.P.O. Box 1041, AUCKLAND,
Tel. (09)849-4160, Fax. (09)849-7811

Norway: Box 1, Manglerud 0612, OSLO,
Tel. (022)74 8000, Fax. (022)74 8341

Pakistan: Philips Electrical Industries of Pakistan Ltd.,
Exchange Bldg. ST-2/A, Block 9, KDA Scheme 5, Clifton,
KARACHI 75600, Tel. (021)587 4641-49,
Fax. (021)577035/5874546

Philippines: PHILIPS SEMICONDUCTORS PHILIPPINES Inc.,
106 Valero St. Salcedo Village, P.O. Box 2108 MCC, MAKATI,
Metro MANILA, Tel. (63) 2 816 6380, Fax. (63) 2 817 3474

Portugal: PHILIPS PORTUGUESA, S.A.,
Rua dr. António Loureiro Borges 5, Arquiparque - Miraflores,
Apartado 300, 2795 LINDA-A-VELHA,
Tel. (01)4163160/4163333, Fax. (01)4163174/4163366

Singapore: Lorong 1, Toa Payoh, SINGAPORE 1231,
Tel. (65)350 2000, Fax. (65)251 6500

South Africa: S.A. PHILIPS Pty Ltd.,
195-215 Main Road Martindale, 2092 JOHANNESBURG,
P.O. Box 7430, Johannesburg 2000,
Tel. (011)470-5911, Fax. (011)470-5494

Spain: Balmes 22, 08007 BARCELONA,
Tel. (03)301 6312, Fax. (03)301 42 43

Sweden: Kottbygatan 7, Akalla. S-164 85 STOCKHOLM,
Tel. (0)8-632 2000, Fax. (0)8-632 2745

Switzerland: Allmendstrasse 140, CH-8027 ZÜRICH,
Tel. (01)488 2211, Fax. (01)481 77 30

Taiwan: PHILIPS TAIWAN Ltd., 23-30F, 66, Chung Hsiao West
Road, Sec. 1. Taipei, Taiwan ROC, P.O. Box 22978,
TAIPEI 100, Tel. (886) 2 382 4443, Fax. (886) 2 382 4444

Thailand: PHILIPS ELECTRONICS (THAILAND) Ltd.,
209/2 Sanpavuth-Bangna Road Prakanong,
Bangkok 10260, THAILAND,
Tel. (66) 2 745-4090, Fax. (66) 2 398-0793

Turkey: Talatpasa Cad. No. 5, 80640 GÜLTEPE/ISTANBUL,
Tel. (0212)279 27 70, Fax. (0212)282 67 07

Ukraine: PHILIPS UKRAINE, 2A Akademika Koroleva str., Office 165,
252148 KIEV, Tel. 380-44-4760297, Fax. 380-44-4766991

United Kingdom: Philips Semiconductors LTD.,
276 Bath Road, Hayes, MIDDLESEX UB3 5BX,
Tel. (0181)730-5000, Fax. (0181)754-8421

United States: 811 East Arques Avenue, SUNNYVALE,
CA 94088-3409, Tel. (800)234-7381, Fax. (708)296-8556

Uruguay: Coronel Mora 433, MONTEVIDEO,
Tel. (02)70-4044, Fax. (02)92 0601

Internet: <http://www.semiconductors.philips.com/ps/>

For all other countries apply to: Philips Semiconductors,
International Marketing and Sales, Building BE-p,
P.O. Box 218, 5600 MD EINDHOVEN, The Netherlands,
Telex 35000 phtcnl, Fax. +31-40-2724825

SCDS47

© Philips Electronics N.V. 1995

All rights are reserved. Reproduction in whole or in part is prohibited without the prior written consent of the copyright owner.

The information presented in this document does not form part of any quotation or contract, is believed to be accurate and reliable and may be changed without notice. No liability will be accepted by the publisher for any consequence of its use. Publication thereof does not convey nor imply any license under patent- or other industrial or intellectual property rights.

Printed in The Netherlands

413061/1100/03/pp16

Date of release: 1995 Dec 13

Document order number:

9397 750 00526