



WT8076 Passive Infrared (PIR) Controller

Version 1.0 25-May-1995

©Waltrend Semiconductor, Inc. All Rights Reserved

GENERAL DESCRIPTION

The WT8076 is a PIR controller IC which integrates amplifier, window detector and light control functions. The light can be controlled by a Relay or Triac with adjustable delay time. A CDS interface is provided to sense day time and night time. A walk-test function helps user while setting up the light set. The line remote control function can switch the light set between auto mode and always-on mode.

FEATURES

- Adjustable detection range
- Adjustable delay time
- CDS interface to differentiate night time and day time
- Walk-test function
- Line remote control to switch auto mode and always on mode
- Relay or Triac output
- High noise immunity
- Low power consumption (operating 500uA, standby 130uA, Typ.)

PIN ASSIGNMENT

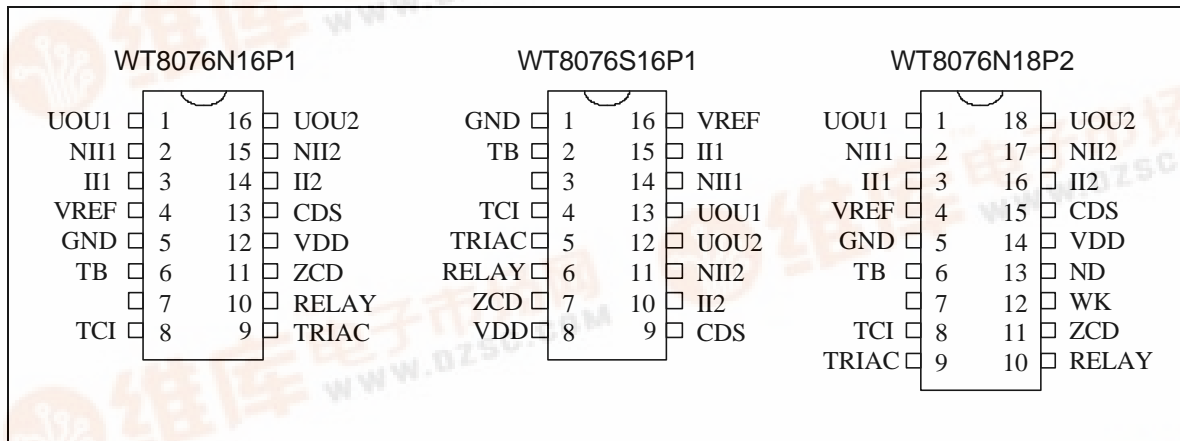

Ordering Information

PART No.	PACKAGE
WT8076N16P1	16 Pin P-DIP
WT8076S16P1	16 Pin SOIC
WT8076N18P2	18 Pin P-DIP

PIN DESCRIPTION

Pin No.			Name	Descriptions
N16P1	S16P1	N18P1		
1	13	1	UOU1	Output of the first stage OP amplifier.
2	14	2	NI1	Non-inverting input of the first stage OP amplifier.
3	15	3	II1	Inverting input of the first stage OP amplifier.
4	16	4	VREF	Reference voltage output.
5	1	5	GND	Ground.
6	2	6	TB	Time Base. A RC oscillator is connected on this pin. Typical frequency is 30kHz.
7	3	7	---	No connection.
8	4	8	TCI	Time control input. A RC oscillator is connected on this pin. It controls the delay time of the light.
9	5	9	TRIAC	Triac control pin. Active low.
10	6	10	RELAY	Relay control pin. Active high.
11	7	11	ZCD	Zero-crossing input. It detects the zero-crossing point of the AC line. The output of TRIAC pin is synchronous to this pin.
*	*	12	WKT	Walk-Test function enable/disable. Internal pull low. The walk-test function is disabled when this pin is high level.
*	*	13	ND	Night and day detection enable/disable. Internal pull low. The night-and-day detection is disabled when this pin is high level.
12	8	14	VDD	Power supply.
13	9	15	CDS	Connect a photo-sensitive resistor to detect night time and day time. If the input level is lower than 1.2V, it is day time. If the input level is higher than 1.9V, it is night time.
14	10	16	II2	Inverting input of the second stage OP amplifier.
15	11	17	NI2	Non-inverting input of the second stage OP amplifier.
16	12	18	UOU2	Output of the second stage OP amplifier.

* WT8076N16P1 and WT8076S16P1 : Walk-Test and Night&Day function is always enabled.

BLOCK DIAGRAM

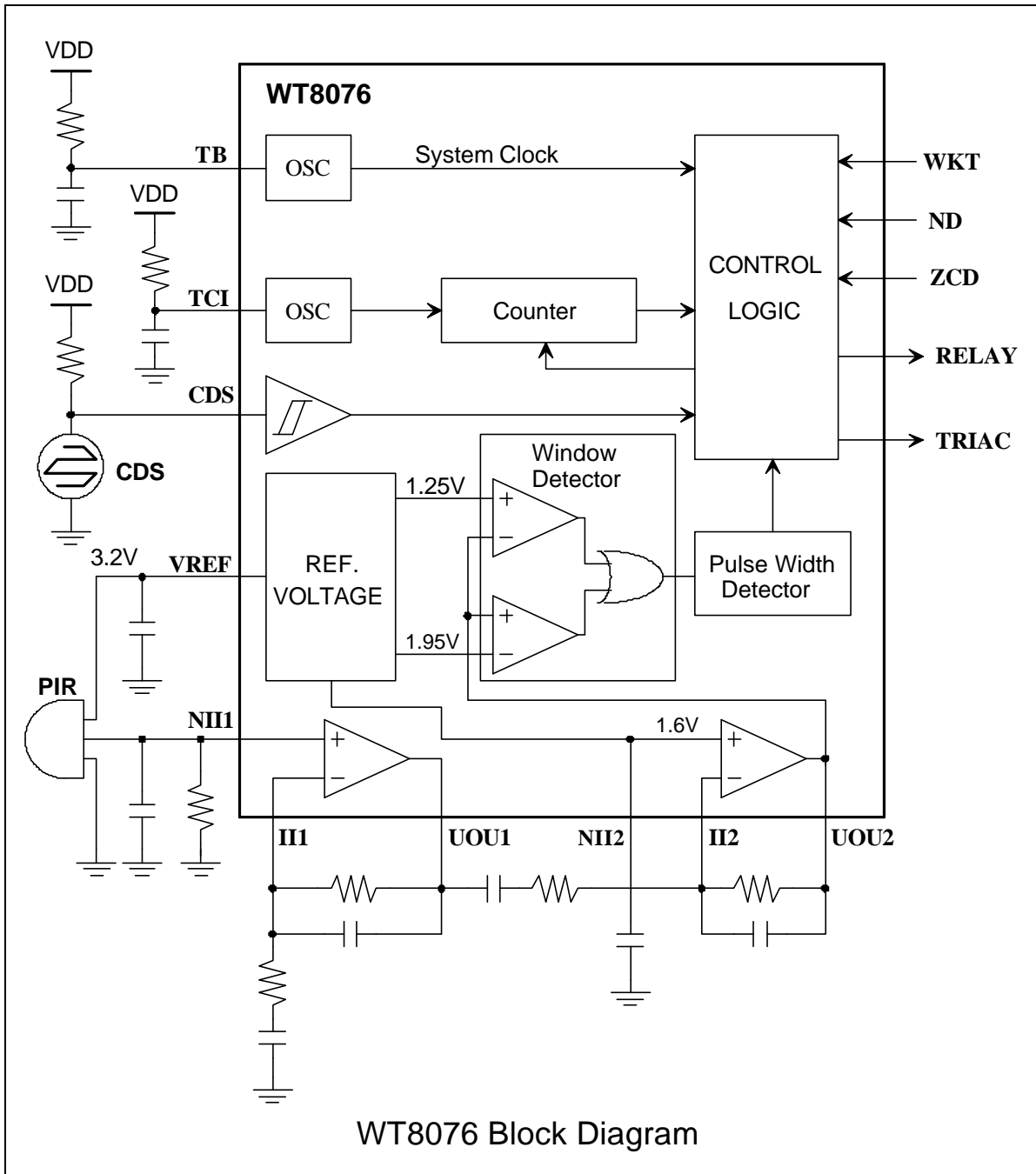

FUNCTIONAL DESCRIPTION

PIR Amplifier

The amplifier has two stages, please see block diagram . The voltage gain and frequency response can be adjusted by the external resistors and capacitors.

Window Detector

If the amplified PIR signal is between V_H (1.95V) and V_L (1.25V), the signal is ignored and the output of the window detector is low level. If the amplified signal is larger than V_H or smaller than V_L , the output of the window detector is high level.

Pulse Width Detector

The pulse width detector detects the pulse width of the window detector's output. If the pulse width is less than 90ms ($f_{TB} = 30kHz$), this pulse is ignored. If the pulse width is larger than 90ms, it will trigger the light to turn on.

Light Control

The light is controlled by the RELAY pin or TRIAC pin. The RELAY pin outputs a high level when a valid pulse is detected. The delay time is determined by the RC on the TCI pin. If another valid pulse occurs during the delay time, the delay time will be reset. Fig. 1 shows the relationships.

The TRIAC pin is an open drain NMOS output. The turn on angle is about 24° .

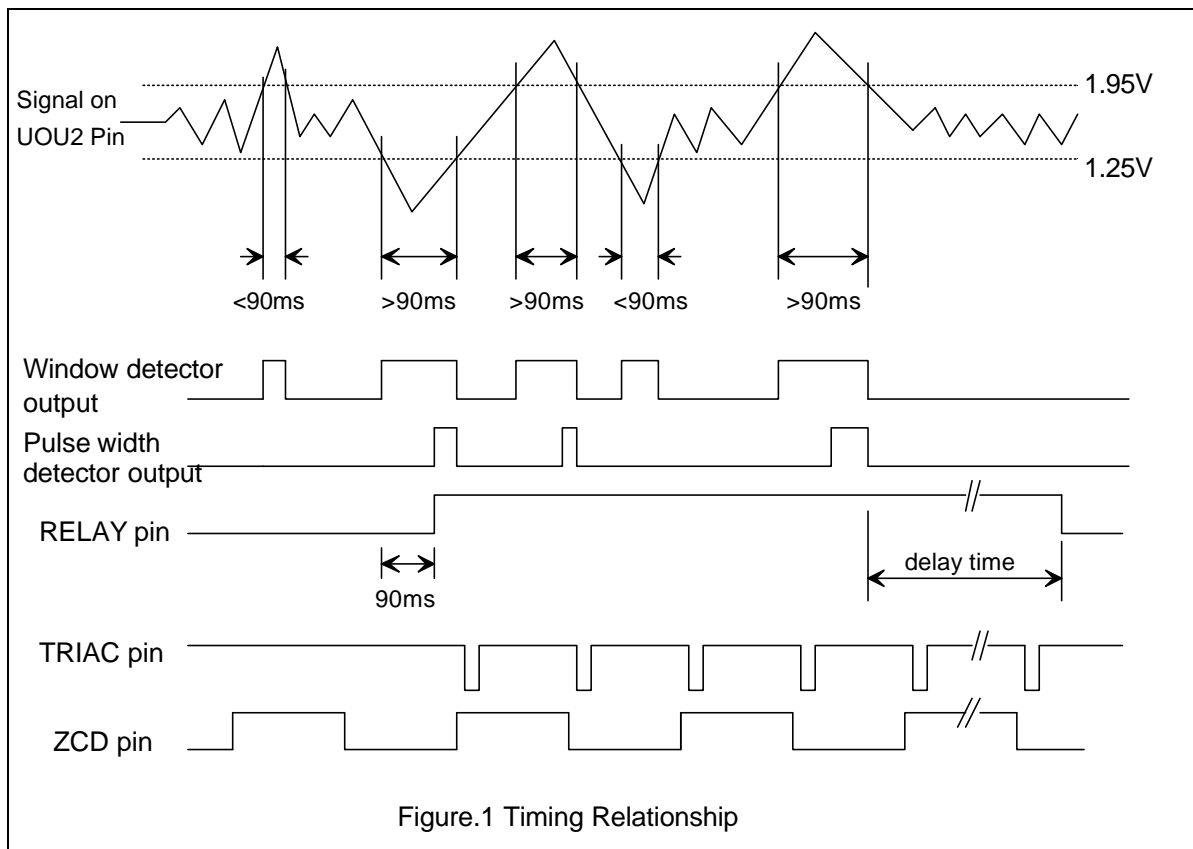

CDS Interface

The CDS interface detects the level on the CDS pin. If the level is higher than 1.95V, it is night time. If the level is lower than 1.25V, it is day time.

Operating Modes

The operating modes of WT8076 are:

(1) Auto mode:

The light will turn on when a valid pulse is detected in the night time.

(2) Always on mode:

If the ND pin is low level, the light is always on in the night time. When it detects day time, the light will be turn off, and back to auto mode.

If the ND pin is high level, the light is always on.

(3) Walk-test mode:

The walk-test mode is active after the power is on. This mode is same as the auto mode except the CDS is ignored. That is, the light will be turn on when a valid pulse is detected no matter it is night time or day time.

Remote Control

To switch auto mode between always on mode, the WT8076 detects the zero crossings of the AC line. If the line switch OFF and ON one time in 3 seconds, it toggles the auto mode and always on mode.

Time Base

The RC oscillator on the TB pin generates the system clock. The frequency is 30kHz typically ($R = 30K\Omega$, $C = 1000pF$).

The following parameters are decided by the time base :

- (1) Trigger angle of the TRIAC (24° , if time base is 30kHz).
- (2) Pulse width (90ms, if time base is 30kHz).
- (3) Remote control switch time.
- (4) Disable PIR after the light is off.
- (5) Total walk-test time.

The RC oscillator on the TCI pin sets the delay time. Figure 2 shows the relationship between delay time and the R ($C = 1000pF$).

ELECTRICAL CHARACTERISTICS

Absolute Maximum Ratings

Item	Symbol	Ratings	Unit
supply voltage	V _{DD}	6	V
Input Voltage	V _{IN}	-0.5 to V _{DD} +0.5	V
Operating Temperature	T _{OPR}	-25 to 70	°C
Storage Temperature	T _{STG}	-65 to 150	°C
Power Dissipation	P _D	500	mW

Note: Stress above those conditions listed may cause permente damage to the device.

Electrical Characteristics (VDD=5.0V, TA=25°C)

Item	Symbol	Test Condition	Min	Typ	Max	Unit
Operating Voltage	V _{DD}		4.5	5	5.5	V
Standby Current	I _{DDs}		-	130	600	mA
Operating Current	I _{DDO}	No load on output.	-	500	1000	mA
Reference Voltage	V _{REF}		3	3.2	3.4	V
Ripple of VREF			-	-	0.5	mV
Time Base Frequency	f _{TB}	R=30K,C=1000p	28	30	32	kHz
CDS V _{T+}	V _{T+}		-	1.95	2.1	V
CDS V _{T-}	V _{T-}		1	1.25	-	V
TCI Frequency	f _{TCI}		-	-	50k	Hz
TRIAC pin Sink Current	I _{OL}	V _{OL} = 1.5V	-	-	15	mA
RELAY pin Source Current	I _{OH}	V _{OH} = 3.5V	-	-	5	mA

Characteristics of OP Amplifier (VDD=5.0V, TA=25°C)

Item	Symb ol	Test Condition	Min	Typ	Max	Unit
Input Bias Current	I _{bias}		-	-	10	nA
Input Offset Current	I _{offset}		-	-	10	nA
Input Offset Voltage	V _{offset}		-	-	5	mV
Output Swing Voltage	V _{swing}	R _L =470K	4	-	-	V
Output Source Current	I _{source}		7	-	-	uA
Output Sink Current	I _{sink}		3.5	-	-	mA
Differential Gain	A _v		-	100	-	dB
Commom Mode Rejection Ration	CMRR		-	65	-	dB
Power Supply Rejection Ration	PSRR		-	80	-	dB

TYPICAL APPLICATION CIRCUIT

WT8076N18P1 Application Circuit For RELAY Output

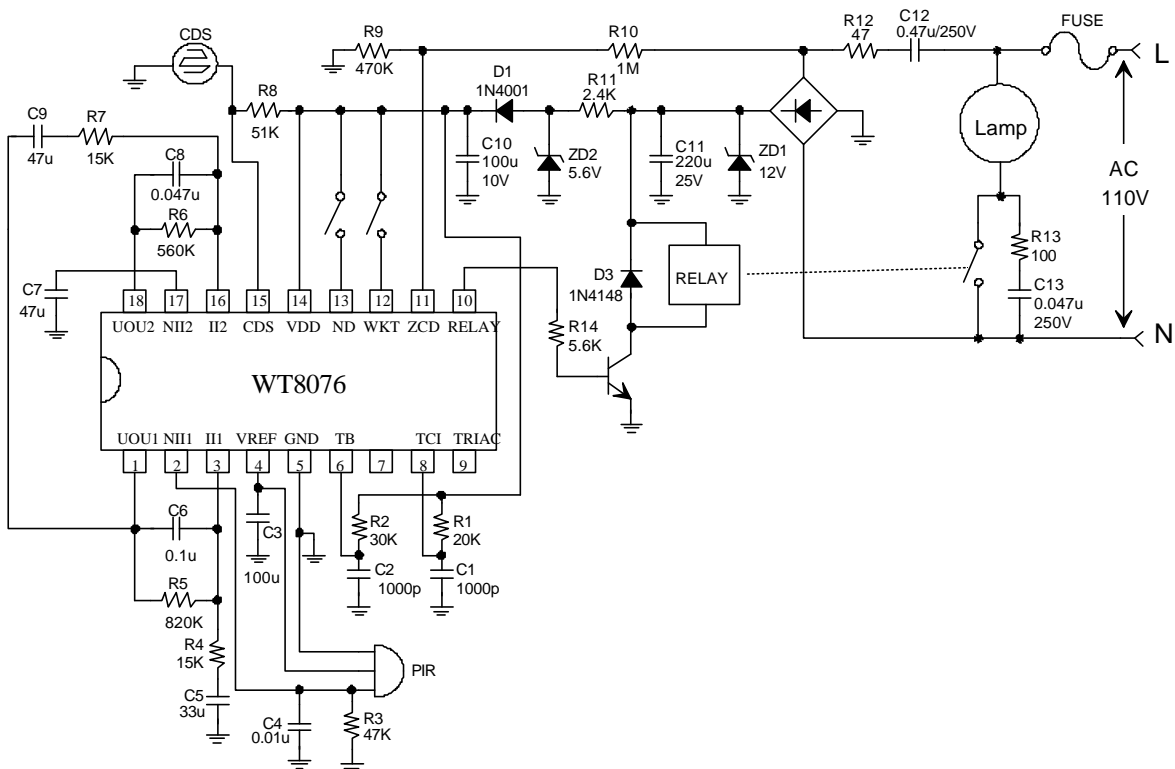

Note:

- (1) To adjust delay time, change R1 value. (R1=20K, delay time is about 10 sec)
- (2) For different CDS, R8 value should be adjusted.

WT8076N18P1 Application Circuit For TRIAC Output

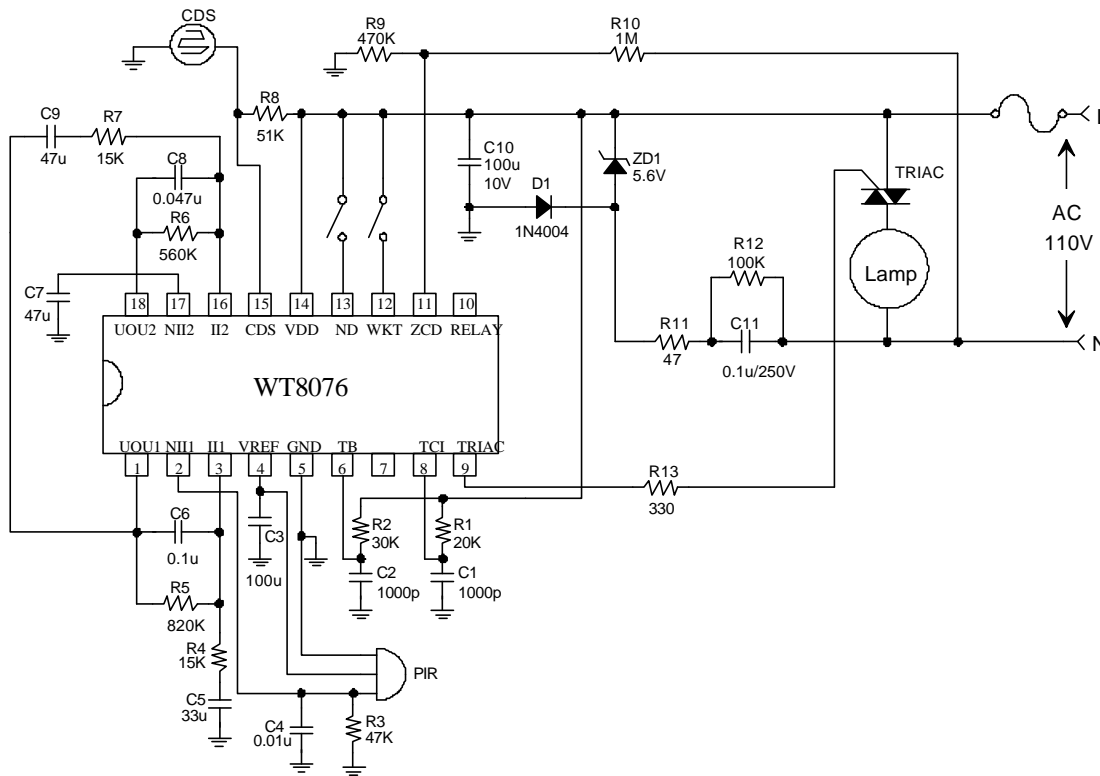

Note:

- (1) To adjust delay time, change R1 value. (R1=20K, delay time is about 10 sec)
- (2) For different CDS, R8 value should be adjusted.