

SONY

CXA3250N

All Band TV Tuner IC with On-chip PLL

Description

The CXA3250N is a monolithic TV tuner IC which integrates local oscillator and mixer circuits for VHF band, local oscillator and mixer circuits for UHF band, an IF amplifier and a tuning PLL onto a single chip, enabling further miniaturization of the tuner.

Features

- Low power consumption (5 V, 69 mA typ.)
- Superior cross modulation
- Balanced UHF oscillator (4 pins) with excellent oscillation stability
- Supports both I²C and 3-wire bus modes
- Automatic identification of 18, 19 or 27-bit control (during 3-wire bus mode)
- On-chip A/D converter (during I²C bus mode)
- On-chip high voltage drive transistor for charge pump
- Reference frequency selectable from 31.25, 50 or 62.5 kHz (when using a 4 MHz crystal)
- Low-phase noise synthesizer
- On-chip 4-output band switch (supports output voltages from 5 to 9 V)

Applications

- TV tuners
- VCR tuners
- CATV tuners

Structure

Bipolar silicon monolithic IC

30 pin SSOP (Plastic)

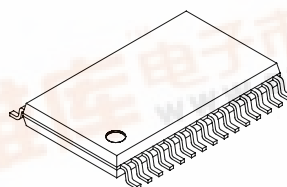

Absolute Maximum Ratings (Ta=25 °C)

- Supply voltage Vcc1, Vcc2 -0.3 to +5.5 V
Vcc3 -0.3 to +10.0 V
- Storage temperature Tstg -55 to +150 °C
- Allowable power dissipation Pd 580 mW
(when mounted on a printed circuit board)

Operating Conditions

- Supply voltage Vcc1, Vcc2 4.75 to 5.30 V
Vcc3 4.75 to 9.45 V
- Operating temperature Topr -25 to +75 °C

This IC has the pins whose electrostatic discharge strength is weak as the operating frequency is high and the high-frequency process is used for this IC. Take care of handling the IC.

Sony reserves the right to change products and specifications without prior notice. This information does not convey any license by any implication or otherwise under any patents or other right. Application circuits shown, if any, are typical examples illustrating the operation of the devices. Sony cannot assume responsibility for any problems arising out of the use of these circuits.



Block Diagram and Pin Configuration

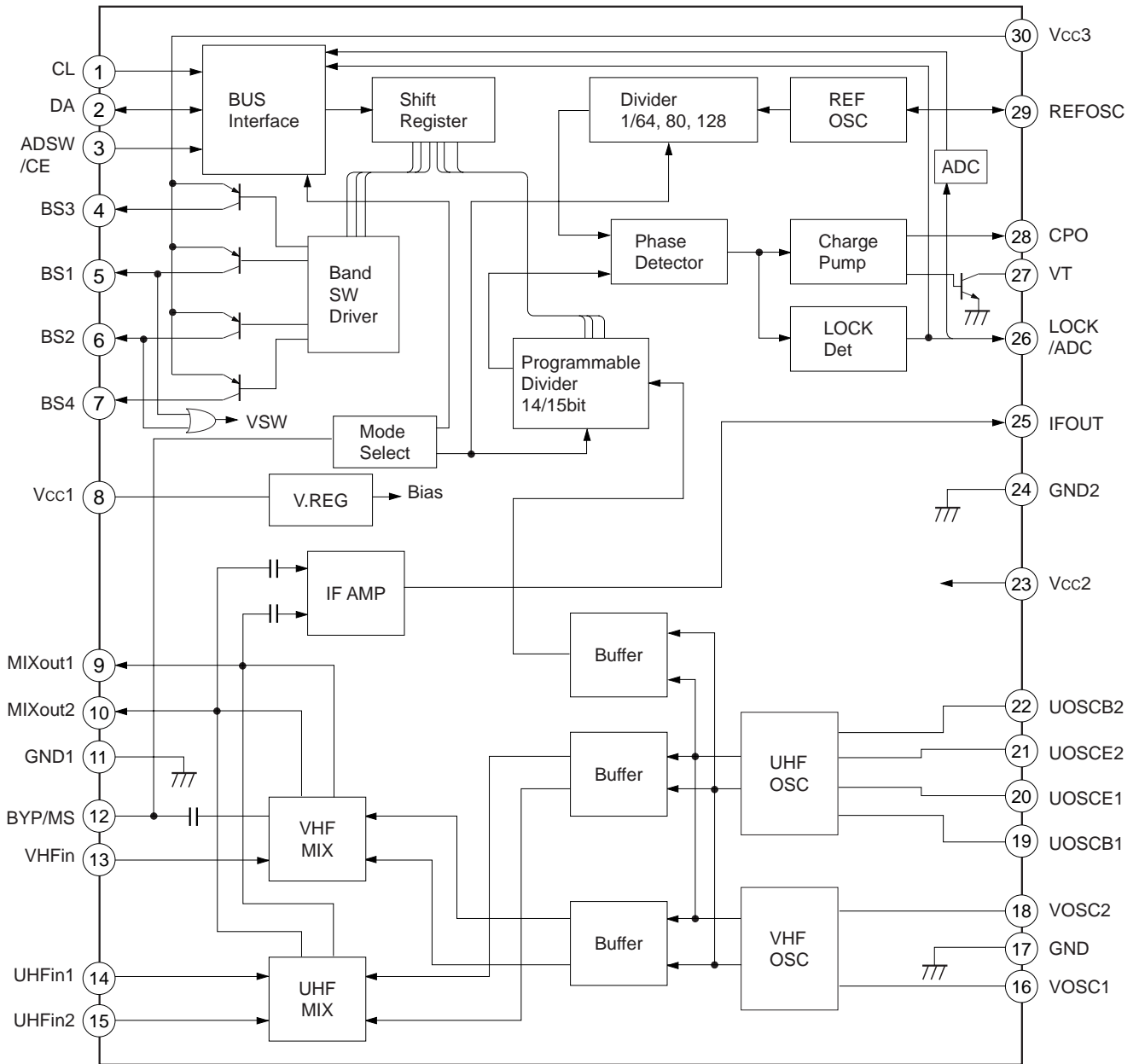

Pin Description

Pin No.	Symbol	Description
1	CL	CLOCK/SCL (I ² C bus)
2	DA	DATA/SDA (I ² C bus)
3	CE/ADSW	Enable/address selection (I ² C bus)
4	BS3	Band switch output 3
5	BS1	Band switch output 1
6	BS2	Band switch output 2
7	BS4	Band switch output 4
8	Vcc1	Analog circuit Vcc
9	MIXOUT1	MIX output
10	MIXOU2	MIX output
11	GND1	Analog circuit GND
12	BYP/MS	VHF input GND and control bus switching
13	VHFIN	VHF input
14	UHFIN1	UHF input
15	UHFIN2	UHF input
16	VOOSC1	VHF oscillator (base input)
17	GND	GND
18	VOOSC2	VHF oscillator (collector output)
19	UOSCB1	UHF oscillator (base pin)
20	UOSCE1	UHF oscillator (emitter pin)
21	UOSCE2	UHF oscillator (emitter pin)
22	UOSCB2	UHF oscillator (base pin)
23	Vcc2	PLL circuit Vcc
24	GND2	PLL circuit GND
25	IFOUT	IF output
26	LOCK/ADC	LOCK signal output/ADC input (I ² C bus)
27	VT	VC drive voltage output (open collector)
28	CPO	Charge pump output (loop filter connection)
29	REFOSC	Crystal connection
30	Vcc3	Band switch power supply

Pin Description and Equivalent Circuit

Pin No.	Symbol	Pin voltage [V]	Equivalent circuit	Description
1	CL	—		Clock input.
2	DA	—		Data input.
3	ADSW/CE	1.25 (when open)		I ² C bus setting : Address selection. Bits 1 and 2 of the address byte are controlled. 3-wire bus setting : Enable input.
4	BS3	ON : 4.8 OFF : 0.0		Band switch outputs. The pin corresponding to the selected band goes High.
7	BS4			
5	BS1			
6	BS2			
8	Vcc1	—	—	Analog circuit power supply.

Pin No.	Symbol	Pin voltage [V]	Equivalent circuit	Description
9	MIXOUT1	—		<p>Mixer output. These pins output the signal with open collector, and they must be connected to the power supply via the load.</p>
10	MIXOUT2	—		
11	GND1	—	—	Analog circuit GND.
12	BYP/MS	3.8 during VHF reception		<p>Pin 12 : VHF input grounding and control bus switching.</p>
		3.8 during UHF reception		
13	VHFin	2.4 during VHF reception		<p>Pin 13 : VHF input. Input format is the unbalanced input.</p>
		2.6 during UHF reception		
14	UHFin1	2.3 during UHF reception		<p>UHF inputs. Input the signal to Pins 14 and 15 symmetrically or ground either of Pin 14 or 15 with the capacitor and input the signal to the rest.</p>
		2.6 during VHF reception		
15	UHFin2	2.3 during UHF reception		<p>UHF inputs. Input the signal to Pins 14 and 15 symmetrically or ground either of Pin 14 or 15 with the capacitor and input the signal to the rest.</p>
		2.6 during VHF reception		
16	VOSC1	2.1 during VHF reception		<p>External resonance circuit connection for VHF oscillator.</p>
		2.3 during UHF reception		
18	VOSC2	4.2 during VHF reception		<p>External resonance circuit connection for VHF oscillator.</p>
		5.0 during UHF reception		
17	GND	—	—	GND for separating the analog and PLL systems.

Pin No.	Symbol	Pin voltage [V]	Equivalent circuit	Description
19	UOSCB1	2.1 during UHF reception		External resonance circuit connection for UHF oscillator.
		2.3 during VHF reception		
20	UOSCE1	1.4 during UHF reception		
		1.8 during VHF reception		
21	UOSCE2	1.4 during UHF reception		
		1.8 during VHF reception		
22	UOSCB2	2.1 during UHF reception		
		2.3 during VHF reception		
23	Vcc2	—	—	PLL circuit power supply.
24	GND2	—	—	PLL circuit GND.
25	IFOUT	2.8		IF output.
26	LOCK/ADC	—		I ² C bus setting : 5-level A/D converter input. 3-wire bus setting : Lock detection. Low when locked, High when unlocked.

Pin No.	Symbol	Pin voltage [V]	Equivalent circuit	Description
27	VT	—		<p>Varicap drive voltage output. This pin outputs the signal with open collector, and this must be connected to the tuning power supply via the load.</p>
28	CPO	2.0		<p>Charge pump output. Connects the loop filter.</p>
29	REFOSC	4.3		<p>Crystal connection for reference oscillator.</p>
30	Vcc3	—	—	<p>Power supply for external supply.</p>

Electrical Characteristics

Circuit Current

(V_{CC}=5 V, T_a=25 °C)

Item	Symbol	Measurement conditions	Min.	Typ.	Max.	Unit
Circuit current A	Alccv	V _{CC} 1 current, band switch output open during VHF operation	37	50	67	mA
	Alccu	V _{CC} 1 current, band switch output open during UHF operation	39	53	71	mA
Circuit current D	Dlcc	V _{CC} 2 current	10	16	22	mA

OSC/MIX/IF Amplifier Block

Item	Symbol	Measurement conditions	Min.	Typ.	Max.	Unit
Conversion gain	CG1	VHF operation f _{RF} =55 MHz	19	22	25	dB
	CG2	VHF operation f _{RF} =360 MHz	21	24	27	dB
	CG3	UHF operation f _{RF} =360 MHz	23	26	29	dB
	CG4	UHF operation f _{RF} =800 MHz	24	27	30	dB
Noise figure *1, *2	NF1	VHF operation f _{RF} =55 MHz		12	15	dB
	NF2	VHF operation f _{RF} =360 MHz		12	15	dB
	NF3	UHF operation f _{RF} =360 MHz		10	13	dB
	NF4	UHF operation f _{RF} =800 MHz		10	13	dB
1 % cross modulation *1, *3	CM1	VHF operation f _D =55 MHz, f _{UD} =±12 MHz	97	101		dB _μ
	CM2	VHF operation f _D =360 MHz, f _{UD} =±12 MHz	97	101		dB _μ
	CM3	UHF operation f _D =360 MHz, f _{UD} =±12 MHz	92	96		dB _μ
	CM4	UHF operation f _D =800 MHz, f _{UD} =±12 MHz	91	95		dB _μ
Maximum output power	Pomax	50 Ω load saturation output	+7	+10		dBm
Switch ON drift *4	Δ fsw1	VHF operation f _{osc} =100 MHz Δ f from 3 s to 3 min after switch ON			±300	kHz
	Δ fsw2	VHF operation f _{osc} =405 MHz Δ f from 3 s to 3 min after switch ON			±600	kHz
	Δ fsw3	UHF operation f _{osc} =405 MHz Δ f from 3 s to 3 min after switch ON			±350	kHz
	Δ fsw4	UHF operation f _{osc} =845 MHz Δ f from 3 s to 3 min after switch ON			±350	kHz

Item	Symbol	Measurement conditions	Min.	Typ.	Max.	Unit
Supply voltage drift *4	Δf_{st1}	VHF operation $f_{osc}=100$ MHz Δf when V_{cc} 5 V changes ± 5 %			± 200	kHz
	Δf_{st2}	VHF operation $f_{osc}=405$ MHz Δf when V_{cc} 5 V changes ± 5 %			± 250	kHz
	Δf_{st3}	UHF operation $f_{osc}=405$ MHz Δf when V_{cc} 5 V changes ± 5 %			± 150	kHz
	Δf_{st4}	UHF operation $f_{osc}=845$ MHz Δf when V_{cc} 5 V changes ± 5 %			± 150	kHz
Oscillator phase noise	C/N V	10 kHz offset	82			dBc/Hz
	C/N U	10 kHz offset	78			
Reference leak	REFL	Phase comparison frequency of 62.5 kHz, CP : 1	55			dB
Lock-up time	LUT 1	VHF operation $f_{osc}=95$ MHz \leftrightarrow $f_{osc}=395$ MHz CP : 1		34	70	ms
	LUT 2	UHF operation $f_{osc}=413$ MHz \leftrightarrow $f_{osc}=847$ MHz CP : 1		36	70	

*1 Value measured with untuned input.

*2 NF meter direct-reading value (DSB measurement).

*3 Value with a desired reception signal input level of -30 dBm, an interference signal of 100 kHz/30 % AM, and an interference signal level where $S/I=46$ dB measured with a spectrum analyzer.

*4 Value when the PLL is not operating.

PLL Block

Item	Symbol	Measurement conditions	Min.	Typ.	Max.	Unit
CL, DA and CE pins						
"H" level input voltage	V _{IH}		3		V _{CC}	V
"L" level input voltage	V _{IL}		GND		1.5	V
"H" level input current	I _{IH}	V _{IH} =V _{CC}		0	-0.1	μA
"L" level input current	I _{IL}	V _{IL} =GND		-2	-4	μA
CPO (charge pump)						
Output current 1	I _{CPO1}	Byte4/bit6=0	±35	±50	±75	μA
Leak current 1	LeakCP1	Byte4/bit6=0			30	nA
Output current 2	I _{CPO2}	Byte4/bit6=1	±140	±200	±300	μA
Leak current 2	LeakCP2	Byte4/bit6=1			100	nA
VT (VC voltage output)						
Maximum output voltage	V _{TH}				33	V
Minimum output voltage	V _{TL}			0.5	0.8	V
LOCK						
"H" output voltage	V _{LOCKH}	When locked	V _{CC} -0.5		V _{CC}	V
"L" output voltage	V _{LOCKL}	When unlocked	0		0.5	V
REFOSC						
Oscillation frequency range	F _{XTOSC}		3		12	MHz
Input capacitance	C _{XTOSC}		22	24	26	pF
Negative resistance	R _{NEG}	Crystal source impedance		-1.4	-0.7	kΩ
Band SW						
Output current	I _{BS}	When ON			-25	mA
Saturation voltage	V _{SAT}	When ON Source current=20 mA		120	240	mV
Leak current	LeakBS	When OFF		0.5	3	μA
Bus timing (I ² C bus)						
SCL clock frequency	f _{SCL}		0		400	kHz
Start waiting time	t _{WSTA}		1300			ns
Start hold time	t _{HSTA}		600			ns
"L" hold time	t _{LOW}		1300			ns
"H" hold time	t _{HIGH}		600			ns
Start setup time	t _{SSTA}		600			ns
Data hold time	t _{HDAT}		0		900	ns
Data setup time	t _{SDAT}		600			ns
Rise time	t _R				300	ns
Fall time	t _F				300	ns
Stop setup time	t _{SSTO}		600			ns
Bus timing (3-wire bus)						
Data setup time	t _{SD}		300			ns
Data hold time	t _{HD}		600			ns
Enable waiting time	t _{WE}		300			ns
Enable setup time	t _{SE}		300			ns
Enable hold time	t _{HE}		600			ns

Electrical Characteristics Measurement Circuit (I²C bus control)

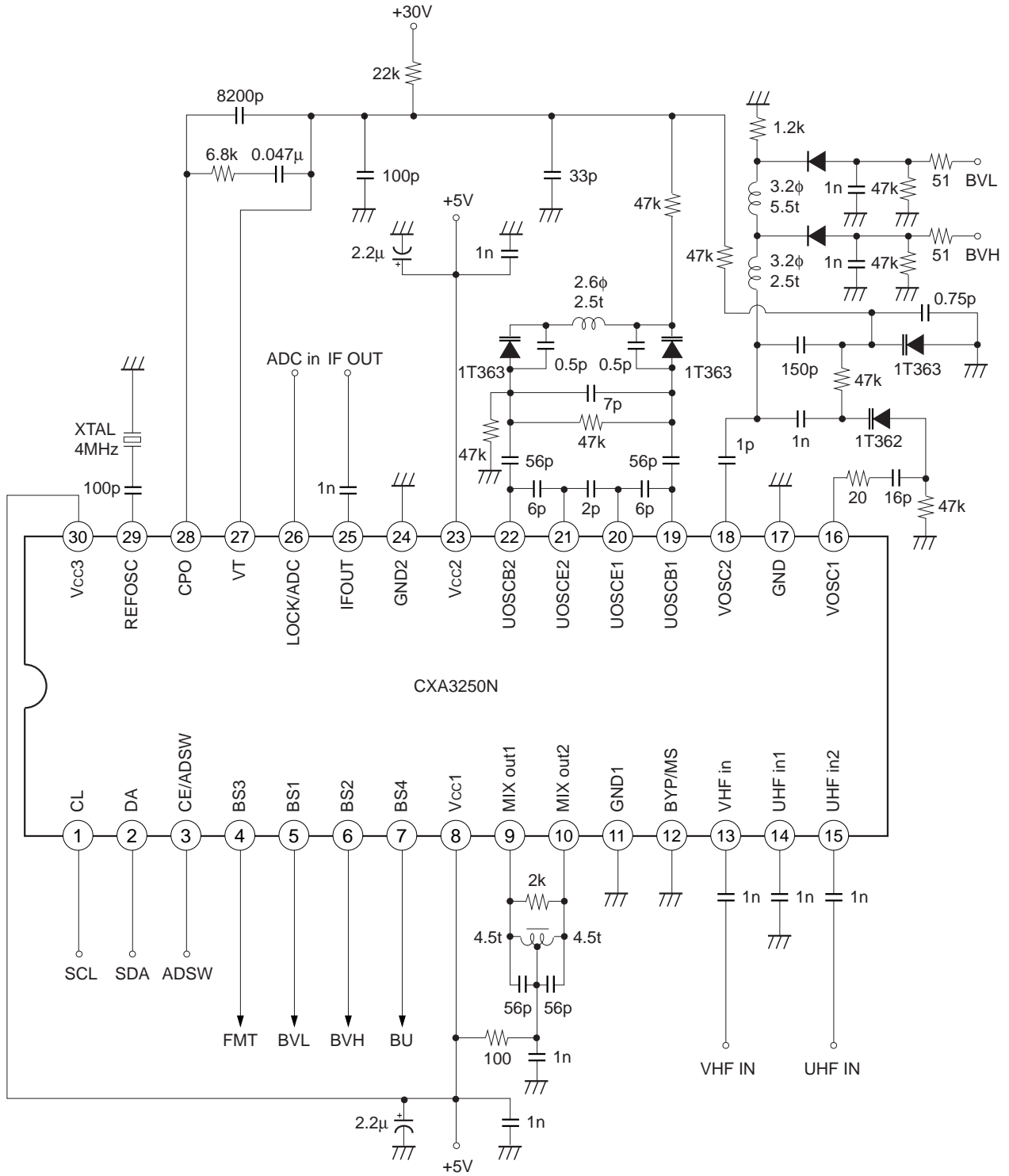

Electrical Characteristics Measurement Circuit (3-wire bus control)

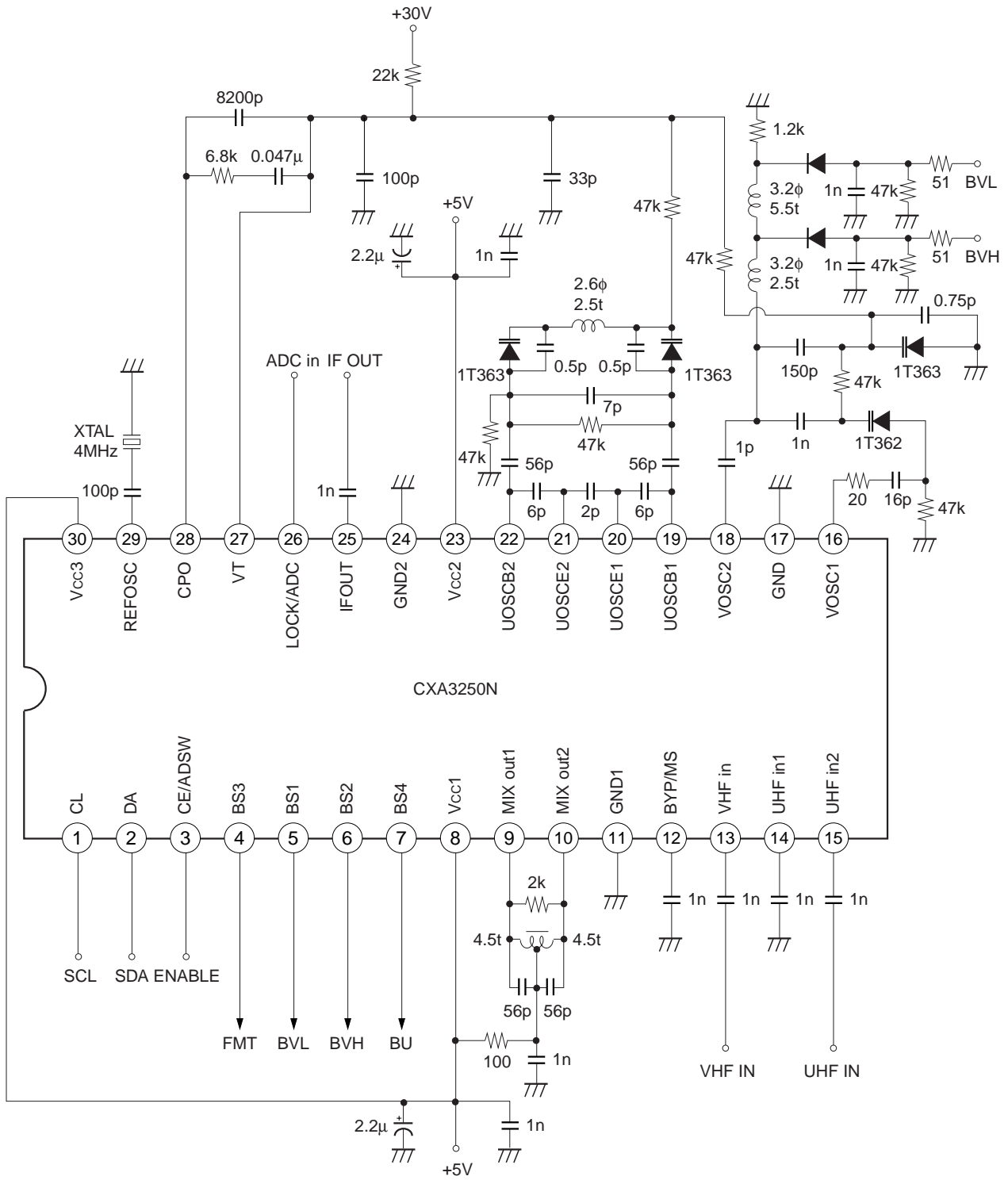

Description of Functions

The CXA3250N is a ground wave broadcast tuner IC which converts frequencies to IF in order to tune and detect only the desired reception frequency of VHF, CATV and UHF band signals.

In addition to the mixer, local oscillation and IF amplifier circuits required for frequency conversion to IF, this IC also integrates a PLL circuit for local oscillation frequency control onto a single chip.

The functions of the various circuits are described below.

1. Mixer circuit

This circuit outputs the frequency difference between the signal input to VHFIN or UHFIN and the local oscillation signal.

2. Local oscillation circuit

A VCO is formed by externally connecting an LC resonance circuit composed of a varicap diode and inductance.

3. IF amplifier circuit

This circuit amplifies the mixer IF output, and consists of an amplifier stage and low impedance output stage.

4. PLL circuit

This PLL circuit fixes the local oscillation frequency to the desired frequency. It consists of a programmable divider, reference divider, phase comparator, charge pump and reference oscillator. The control format supports both the I²C bus and 3-wire bus formats.

During I²C bus control, the frequency steps of 31.25, 50 or 62.5 kHz can be selected by the data-based reference divider frequency division setting value.

During 3-wire bus control, these frequency steps can be selected by the combination of the communication word length (18 or 19 bits) and the voltage applied to the BYP/MS pin.

5. Band switch circuit

The CXA3250N has four sets of built-in PNP transistors for switching between the VL, VH and UHF bands and for switching the FM trap, etc. These PNP transistors can be controlled by the bus data.

The emitters for these PNP transistors are connected to an independent power supply pin (Vcc3) from the oscillator, mixer and PLL circuits, and support either 5 V or 9 V as the RF amplifier power supply.

Description of Analog Block Operation

(See the Electrical Characteristics Measurement Circuit.)

VHF oscillator circuit

- This circuit is a differential amplifier type oscillator circuit. Pin 18 is the output and Pin 16 is the input. Oscillation is performed by connecting an LC resonance circuit including a varicap to Pin 18 via coupled capacitance, inputting to Pin 16 with feedback capacitance, and applying positive feedback.
- The amplifier between Pins 16 and 18 has an extremely high gain. Therefore, care should be taken to avoid creating parasitic capacitance, resistance or other feedback loops as this may produce abnormal oscillation.

VHF mixer circuit

- The mixer circuit employs a double balanced mixer with little local oscillation signal leakage. The input format is base input type, with Pin 12 grounded via a capacitor and the RF signal input to Pin 13. (Pin 12 can also be used to switch the PLL mode according to the applied DC voltage value.)
- The RF signal is fed from the oscillator, converted to IF frequency and output from Pins 9 and 10.

UHF oscillator circuit

- This oscillator circuit is designed so that two collector ground type Colpitts oscillators perform differential oscillation operation via an LC resonance circuit including a varicap.
- Resonance capacitance is connected between Pins 19 and 20, Pins 20 and 21, and Pins 21 and 22, and an LC resonance circuit including a varicap is connected between Pins 19 and 22.

UHF mixer circuit

- This circuit employs a double balanced mixer like the VHF mixer circuit. The input format is base input type, with Pins 14 and 15 as the RF input pins. The input method can be selected from balanced input consisting of differential input to Pins 14 and 15 or unbalanced input consisting of grounding Pin 14 via a capacitor and input to Pin 15.
- Pins 9 and 10 are the mixer outputs.

IF amplifier circuit

- The signals frequency converted by the mixer are output from Pins 9 and 10, and at the same time are AC coupled inside the IC and input to the IF amplifier.
- Single-tuned filters are connected to Pins 9 and 10 in order to improve the interference characteristics of the IF amplifier.
- The signal amplified by the IF amplifier is output from Pin 25. The output impedance is approximately 75 Ω .

Description of PLL Block

This IC supports both I²C bus and 3-wire bus control.

The I²C bus conforms to the standard I²C bus format, and bidirectional bus control is possible consisting of a write mode in which various data are received and a read mode in which various data are sent.

The 3-wire bus is equipped with an 18- or 19-bit auto identify function, and the frequency step can be switched according to the voltage applied to the BYP/MS pin.

The PLL of this IC does not have a fixed frequency division circuit and performs high-speed phase comparison, providing low reference leak and quick lock-up time characteristics.

During power-on (V_{cc2}), the power-on reset circuit operates to initialize the frequency data to all “0” and the band data to all “OFF”. Power-on reset is performed when V_{cc2}=2.5 V at room temperature (T_a=25 °C).

Pin Function Table

Symbol	I ² C bus	3-wire bus
	CL	SCL input
DA	SDA I/O	DATA input
ADSW/CE	Address selection	ENABLE input
LOCK/ADC	ADC input	LOCK output

1.) PLL Mode Setting Method

The selected control bus is set according to the BYP/MS pin (Pin 12) voltage.

BYP/MS pin	Control bus
GND	I ² C bus
OPEN	3-wire bus
V _{cc}	3-wire bus

During 3-wire bus control, the transferred bit length (18, 19 or 27 bits) is automatically identified.

During 18- or 19-bit transfer, the frequency steps in the table below are set according to the combination of the BYP/MS pin voltage and the bit length. This IC does not have a fixed frequency division circuit, so the phase comparison frequency becomes the frequency step.

BYP/MS pin voltage	Transfer bit length	Reference divider	Phase comparison frequency	Frequency step*
OPEN	18	64	62.5 kHz	62.5 kHz
OPEN	19	128	31.25 kHz	31.25 kHz
OPEN or V _{cc}	27	Selectable from 64, 80 or 128	62.5 kHz/ 50.0 kHz/ 31.25 kHz	62.5 kHz/ 50.0 kHz/ 31.25 kHz
V _{cc}	18	80	50.0 kHz	50.0 kHz
V _{cc}	19	80	50.0 kHz	50.0 kHz

* Phase comparison frequency and frequency step are for when the crystal oscillation=4 MHz.

2.) Programming

The VCO lock frequency is obtained according to the following formula.

$$f_{osc} = f_{ref} \times (32 M + S)$$

f_{osc} : local oscillator frequency

f_{ref} : phase comparison frequency

M : main divider frequency division ratio

S : swallow counter frequency division ratio

The variable frequency division ranges of M and S are as follows, and are set as binary.

$$S < M \leq 1023 \quad (S < M \leq 511 \text{ during 18-bit transfer})$$

$$0 \leq S \leq 31$$

3.) I²C Bus Control

This IC conforms to the standard I²C bus format, and bidirectional bus control is possible consisting of a write mode in which various data are received and a read mode in which various data are sent. Write and read modes are recognized according to the setting of the final bit (R/W bit) of the address byte. Write mode is set when the R/W bit is "0" and read mode is set when the R/W bit is "1".

3-1) Address settings

Up to four addresses can be selected by the hardware bit settings, so that multiple PLL can exist within one system.

The responding address can be set according to the ADSW/CE pin voltage.

Address

1	1	0	0	0	MA1	MA0	R/W
---	---	---	---	---	-----	-----	-----

Hardware bits

CE pin voltage	MA1	MA0
0 to 0.1 V _{CC}	0	0
OPEN or 0.2 V _{CC} to 0.3 V _{CC}	0	1
0.4 V _{CC} to 0.6 V _{CC}	1	0
0.9 V _{CC} to V _{CC}	1	1

3-2) Write mode

Write mode is used to receive various data. In this mode, byte 1 contains the address data, bytes 2 and 3 contain the frequency data, byte 4 contains the control data, and byte 5 contains the band switch data. These data are latch transferred in the manner of byte 1, byte 2 + byte 3, and byte 4 + byte 5.

When the correct address is received and acknowledged, the data is recognized as frequency data if the first bit of the next byte is "0", and as control data and band switch data if this bit is "1".

Also, when data transmission is stopped part-way, the previously programmed data is valid. Therefore, once the control and band switch data have been programmed, 3-byte commands consisting of the address and frequency data are possible.

Further, even if the I²C bus stop conditions are not met, data can be input by sending the start conditions and the new address.

The control format is as shown in the table below.

Write-mode : Slave Receiver

	MSB							LSB	
MODE	bit7	bit6	bit5	bit4	bit3	bit2	bit1	bit0	
Address byte	1	1	0	0	0	MA1	MA0	0	A
Divider byte 1	0	M9	M8	M7	M6	M5	M4	M3	A
Divider byte 2	M2	M1	M0	S4	S3	S2	S1	S0	A
Control byte	1	CP	0	CD	X	R1	R0	OS	A
Band SW byte	X	X	X	X	BS4	BS3	BS2	BS1	A

X : Don't care

- A : Acknowledge bit
- MA0, MA1 : address setting
- M0 to : main divider frequency division ratio setting
- S0 to : swallow counter frequency division ratio setting
- CD : charge pump OFF (when "1")
- OS : varicap output OFF (when "1")
- CP : charge pump current switching (200 μ A when "1", 50 μ A when "0")
- BS1 to BS4 : band switch control (output PNP transistor ON when "1")
- R0, R1 : reference divider frequency division ratio setting.
See the Reference Divider Frequency Division Ratio Table.

Reference Divider Frequency Division Ratio Table

R1	R0	Reference divider
0	1	128
1	1	64
X	0	80

X : Don't care

3-3) Read mode

In read mode, the phase comparator locked/unlocked status and 5-level A/D converter input pin voltage status are transmitted and output to the master.

The read data format is as shown in the table below.

Read mode : Slave Transmitter

MODE	bit7	bit6	bit5	bit4	bit3	bit2	bit1	bit0	
Address byte	1	1	0	0	0	MA1	MA0	0	A
Status byte	X	FL	1	1	1	A2	A1	A0	A

A : Acknowledge bit

MA0, MA1 : address setting

FL : lock detection signal (1: locked, 0: unlocked)

A0 to A1 : A/D converter (See the table below.)

5-level A/D Converter Output Table

Voltage applied to LOCK/ADC pin	A1	A1	A0
0.6 Vcc2 to Vcc2	1	0	0
0.45 Vcc2 to 0.6 Vcc2	0	1	1
0.3 Vcc2 to 0.45 Vcc2	0	1	0
0.15 Vcc2 to 0.3 Vcc2	0	0	1
0 to 0.15 Vcc2	0	0	0

4.) 3-Wire Bus Control

The following transfer bit length formats are automatically identified during 3-wire bus control.

- 18 bits : Band data (4 bits) + frequency data (14 bits)
- 19 bits : Band data (4 bits) + frequency data (15 bits)
- 27 bits : Band data (4 bits) + frequency data (15 bits) + test data (8 bits)

4-1) 18-bit data transfer

Data is loaded at the rising edge of the clock signal while the enable signal is high, and is latched at the falling edge of the enable signal.

The clocks during the enable period are counted, and when 18 bits have been loaded, the programmable divider “M9” data is set to “0” and the reference divider frequency division ratio is automatically set to “1/80” when the BYP/MS pin voltage is V_{cc} or to “1/64” when the BYP/MS pin is DC open.

18-bit data format

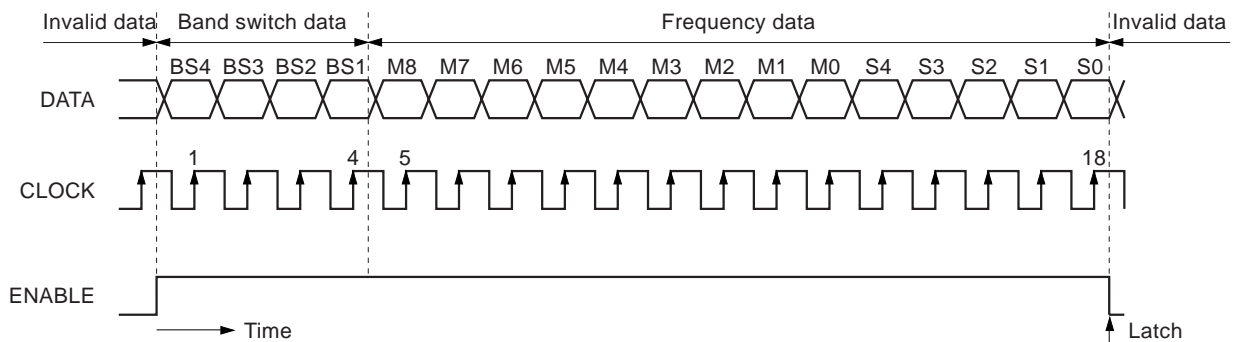

4-2) 19-bit data transfer

Data is loaded at the rising edge of the clock signal while the enable signal is high, and is latched at the falling edge of the enable signal.

The clocks during the enable period are counted, and when 19 bits have been loaded, the reference divider frequency division ratio is automatically set to “1/80” when the BYP/MS pin voltage is V_{cc} or to “1/128” when the BYP/MS pin is DC open.

19-bit data format

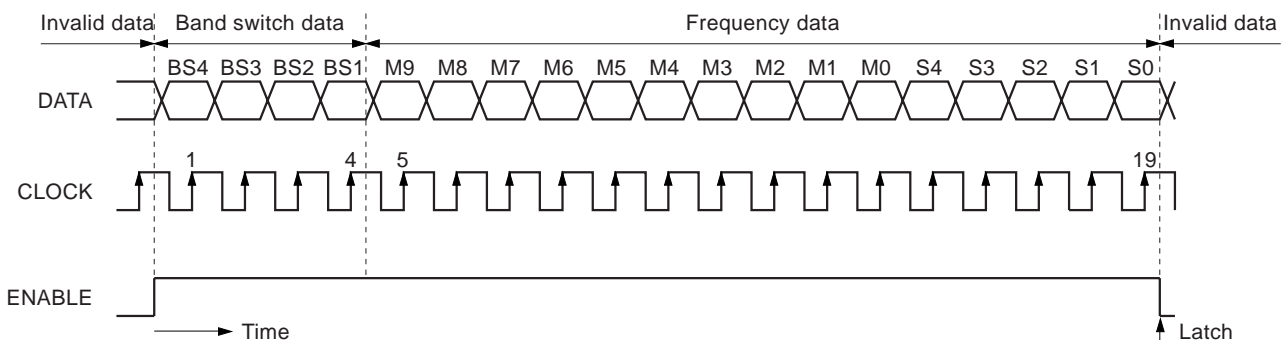

4-3) 27-bit data transfer

The 3-wire bus also automatically supports the 27-bit format in which various control data are transferred in addition to the band and frequency data.

Data is loaded at the rising edge of the clock signal while the enable signal is high, and is latched at the falling edge of the enable signal.

The clocks during the enable period are counted, and 27 bits of data as counted from the rising edge of the enable signal are loaded as valid data.

27-bit data format

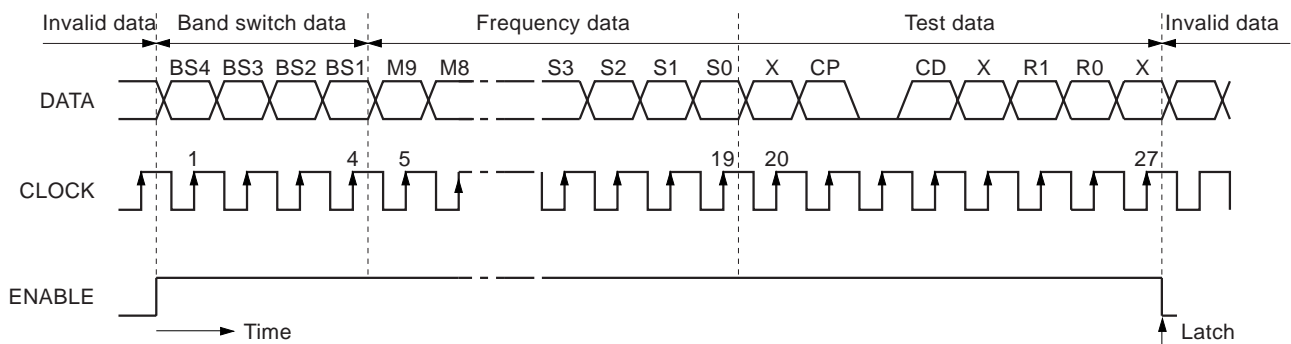

- M0 to : main divider frequency division ratio setting
- S0 to : swallow counter frequency division ratio setting
- CD : charge pump OFF (when "1")
- OS : varicap output OFF (when "1")
- CP : charge pump current switching (200 μ A when "1", 50 μ A when "0")
- BS1 to BS4 : band switch control (output PNP transistor ON when "1")
- R0, R1 : Reference divider frequency division ratio setting.

Reference Divider Frequency Division Ratio Table

R1	R0	Reference divider
0	1	128
1	1	64
X	0	80

X : Don't care

I²C Bus Timing Chart

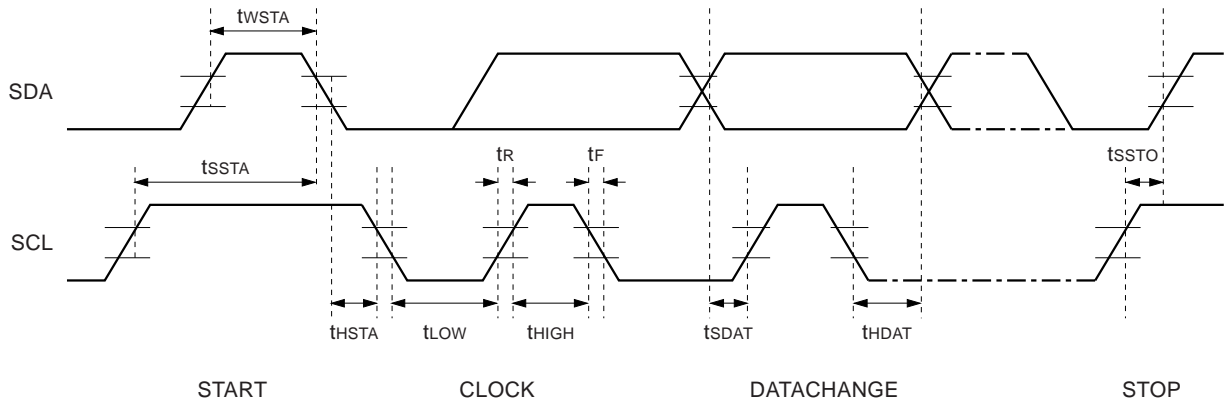

t_{SSTA} =Start setup time
 t_{WSTA} =Start waiting time
 t_{HSTA} =Start hold time
 t_{LOW} =LOW clock pulse width
 t_{HIGH} =HIGH clock pulse width
 t_{SDAT} =Data setup time
 t_{HDAT} =Data hold time
 t_{SSSTO} =Stop setup time
 t_{R} =Rise time
 t_{F} =Fall time

3-Wire Bus Timing Chart

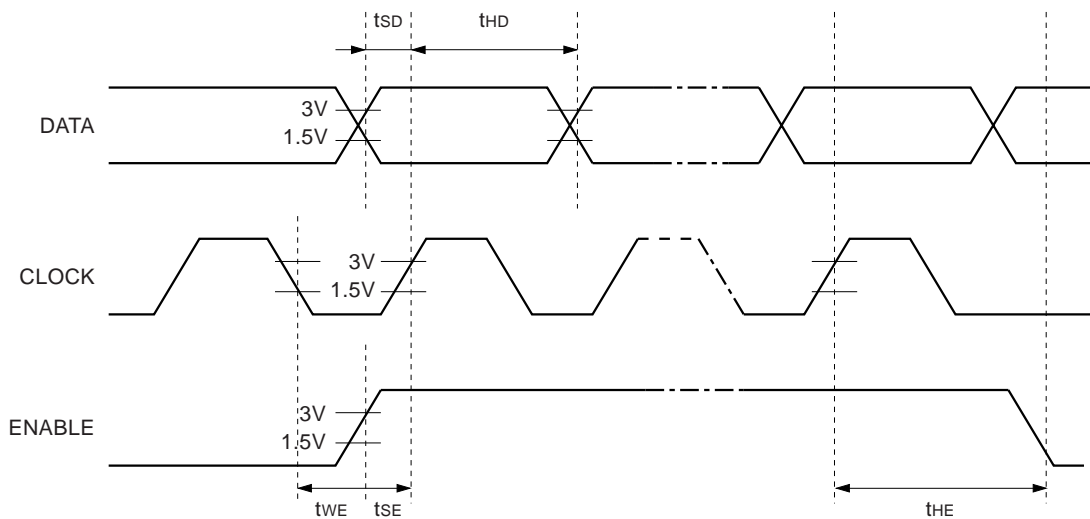

t_{SD} =Data setup time
 t_{HD} =Data hold time
 t_{SSE} =Enable setup time
 t_{HE} =Enable hold time
 t_{WE} =Enable waiting time

Example of Representative Characteristics

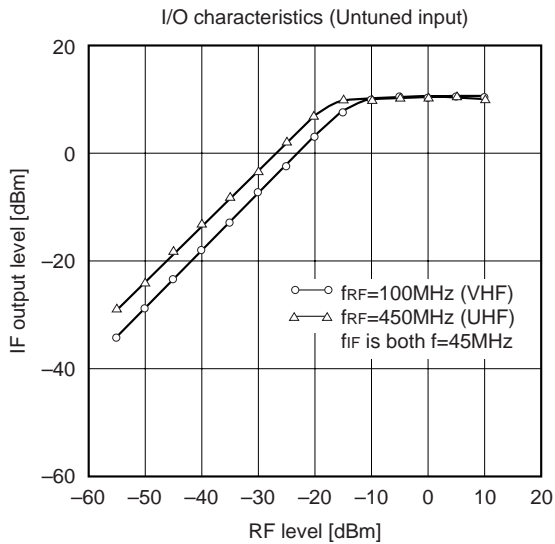
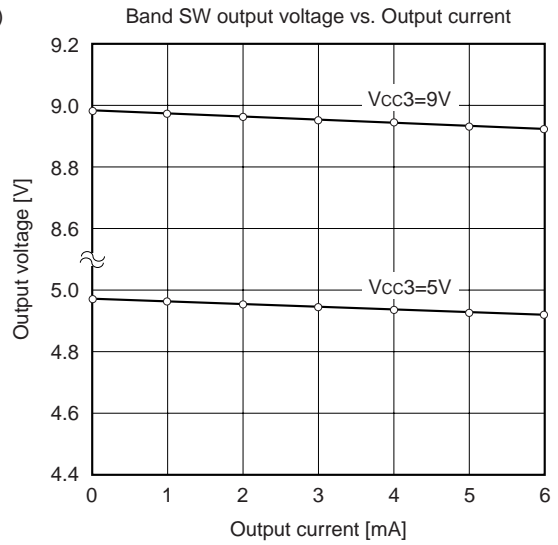
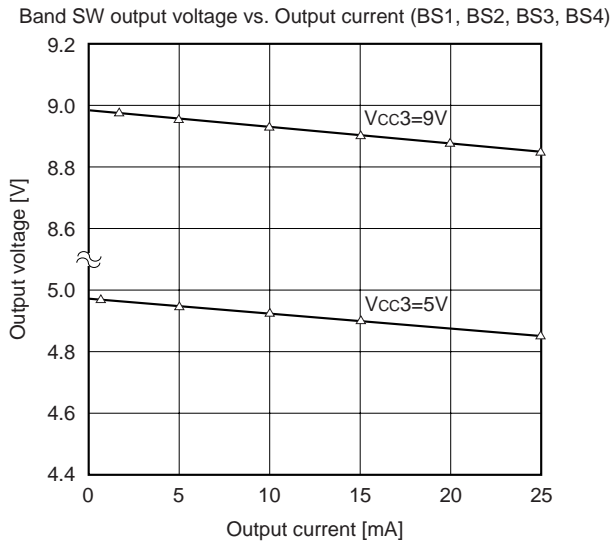
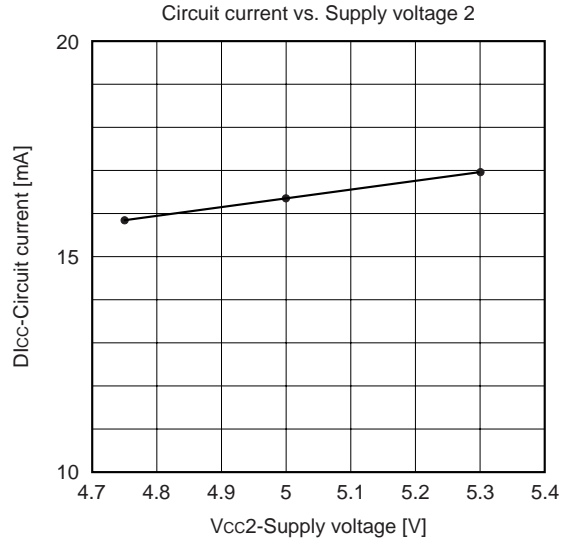
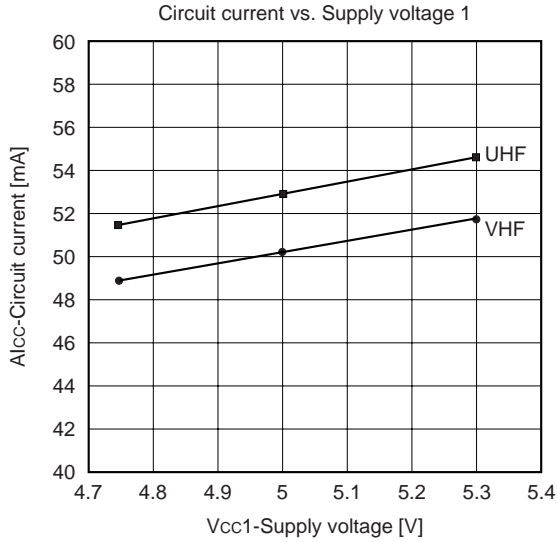

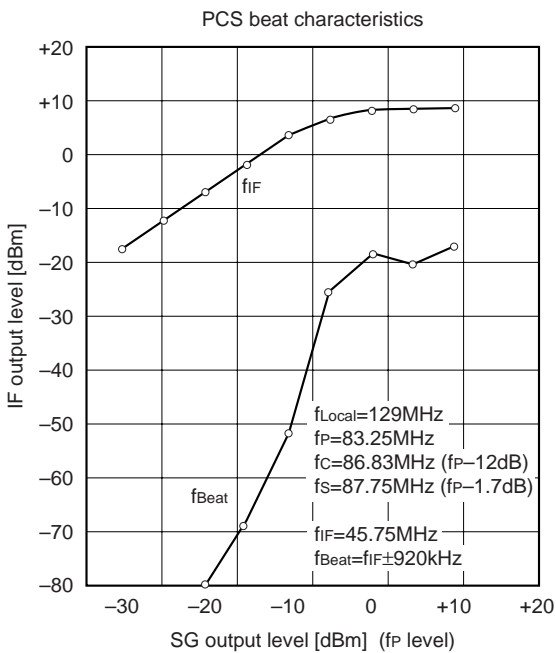
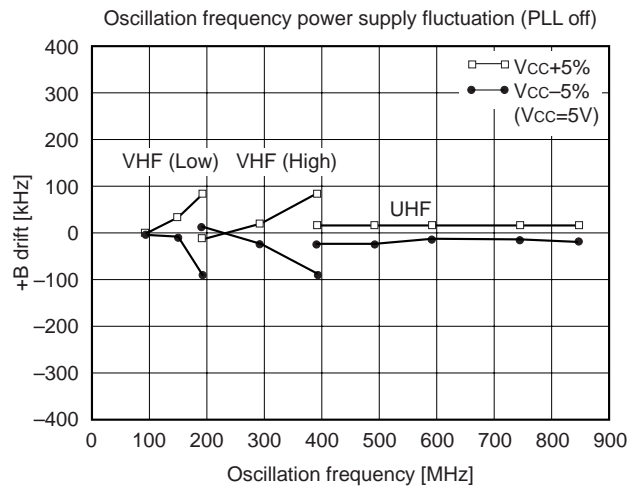
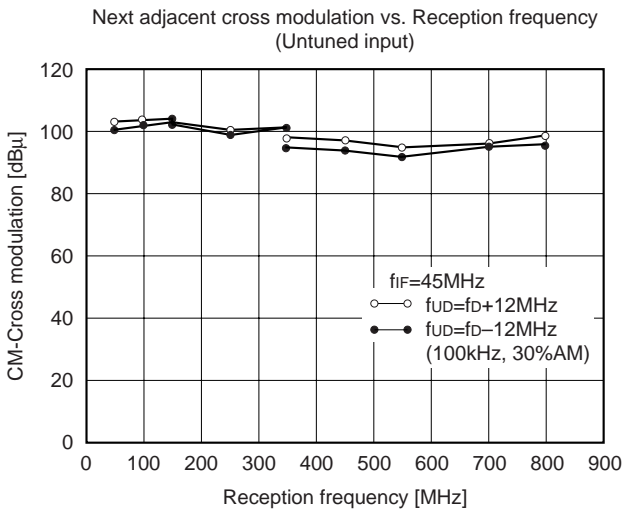
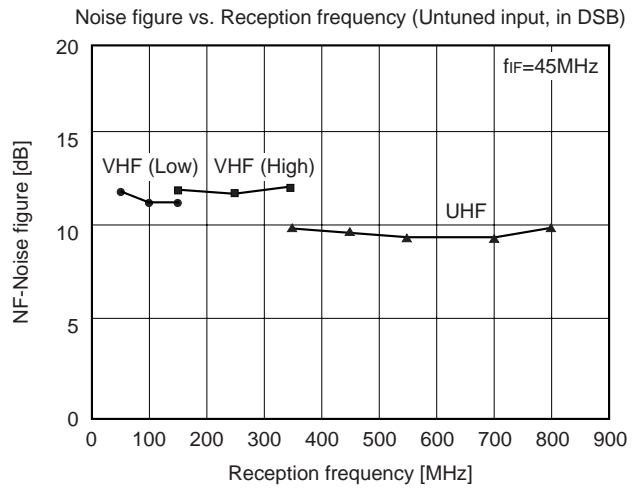
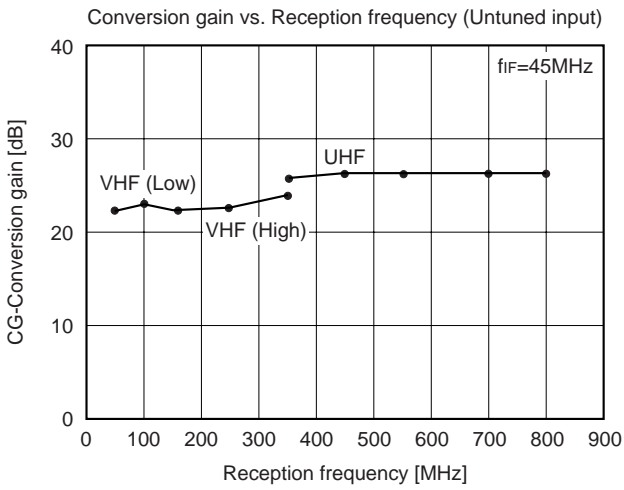

Tuning Response Time 1

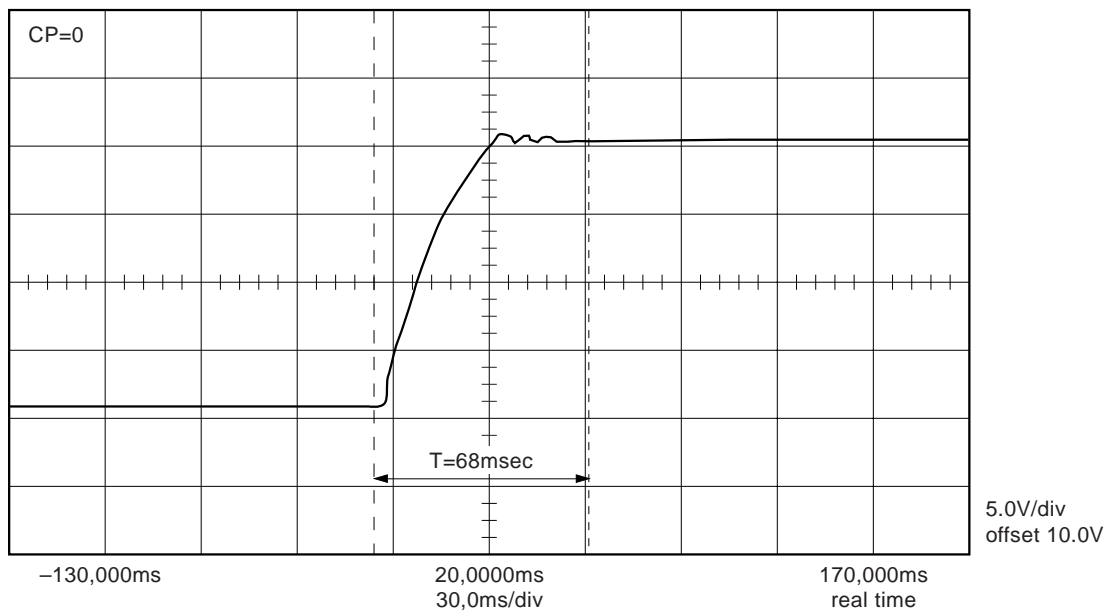
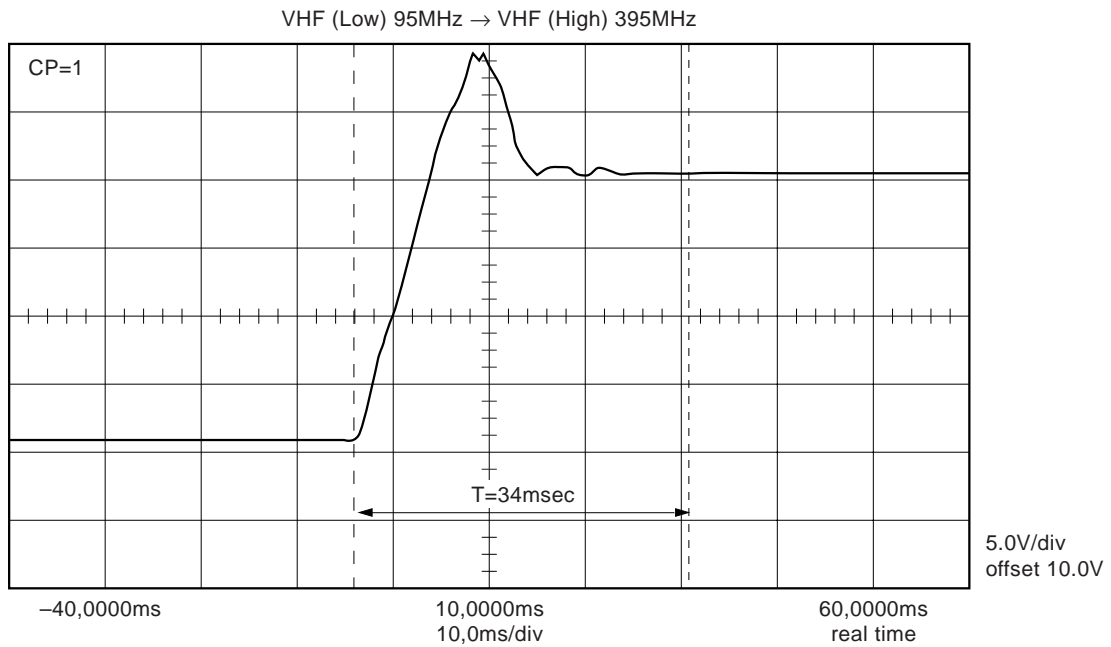

Tuning Response Time 2

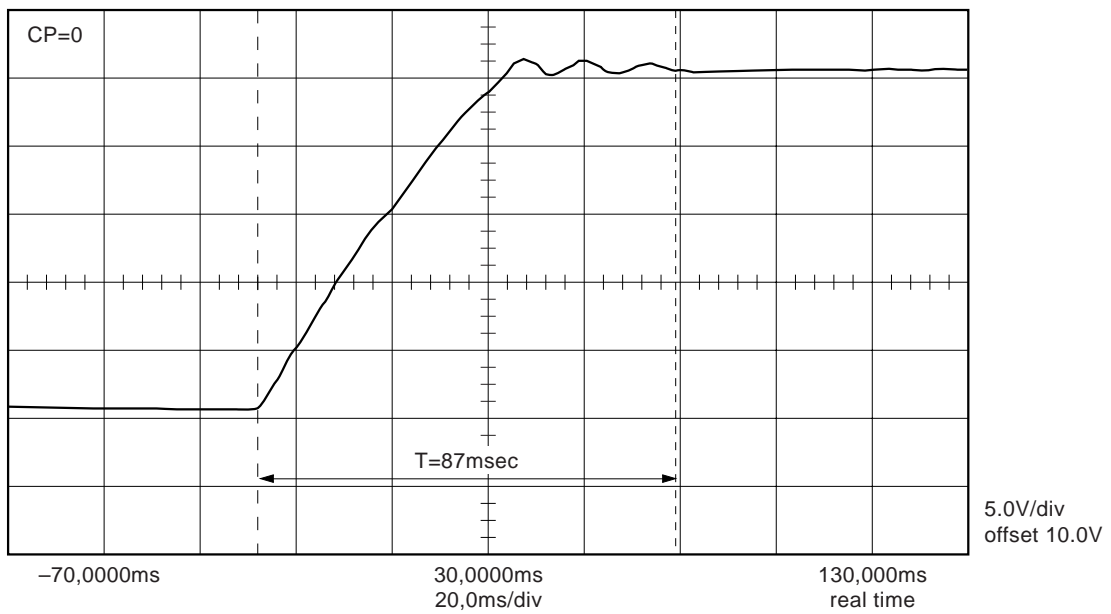
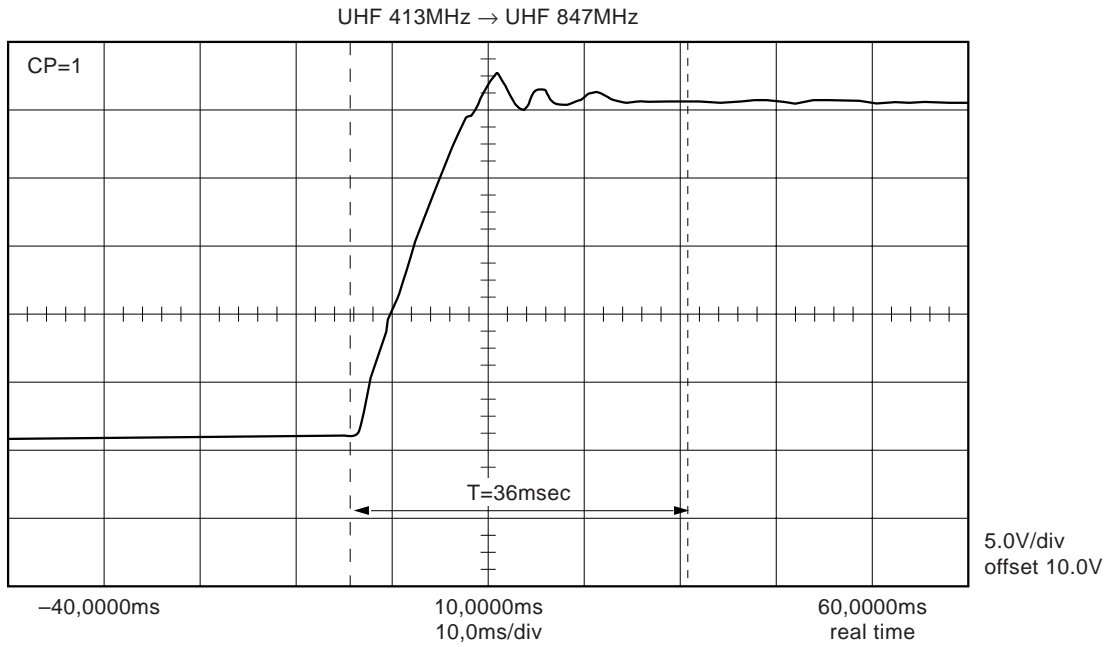

Tuning Response Time 3

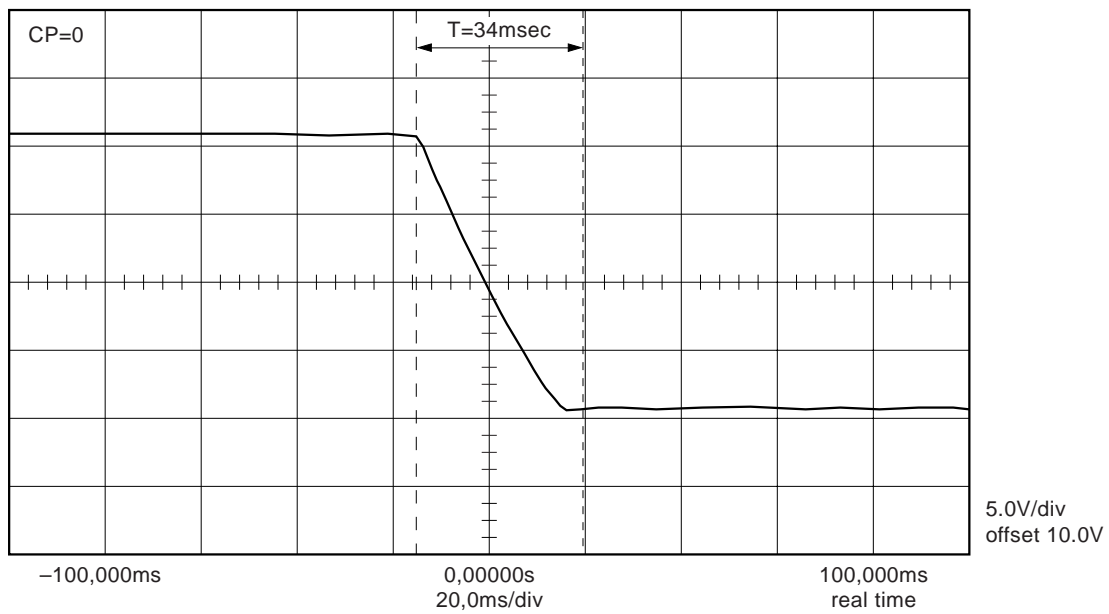
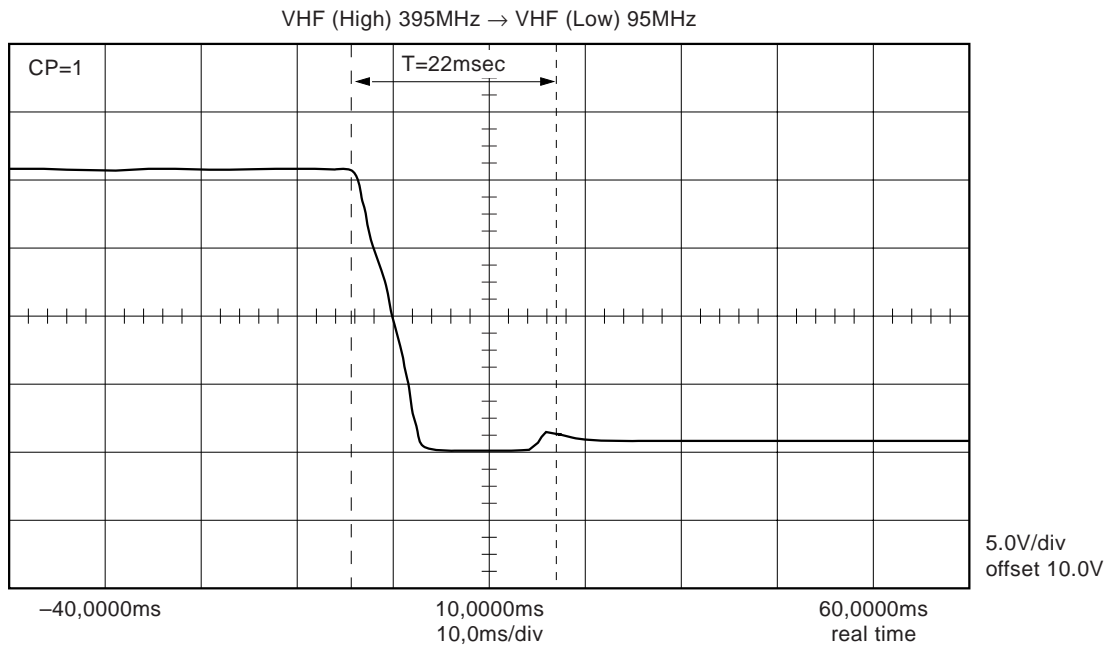

Tuning Response Time 4

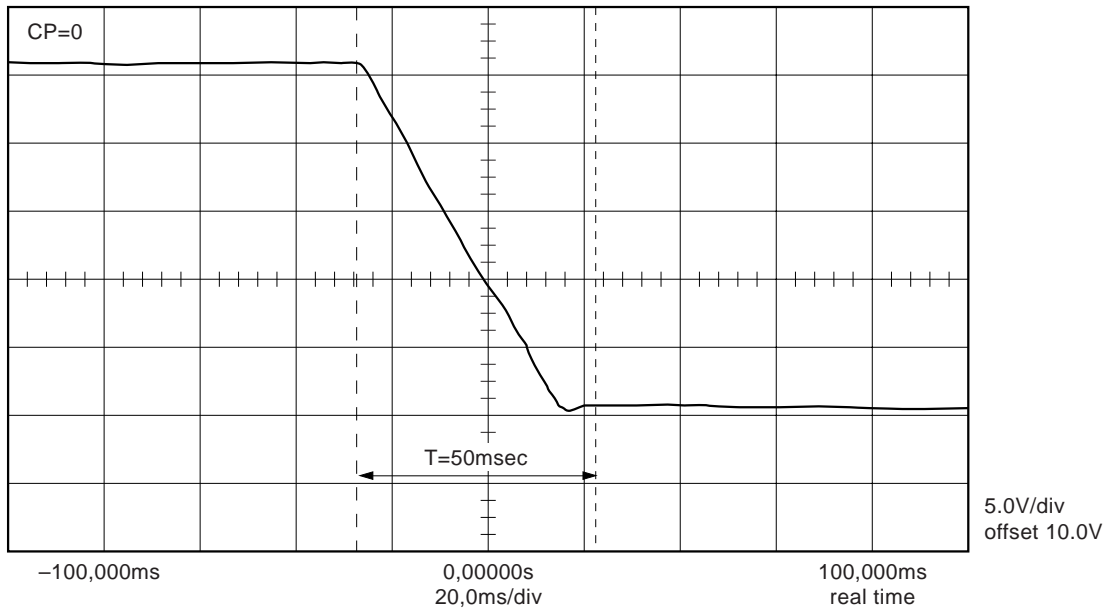
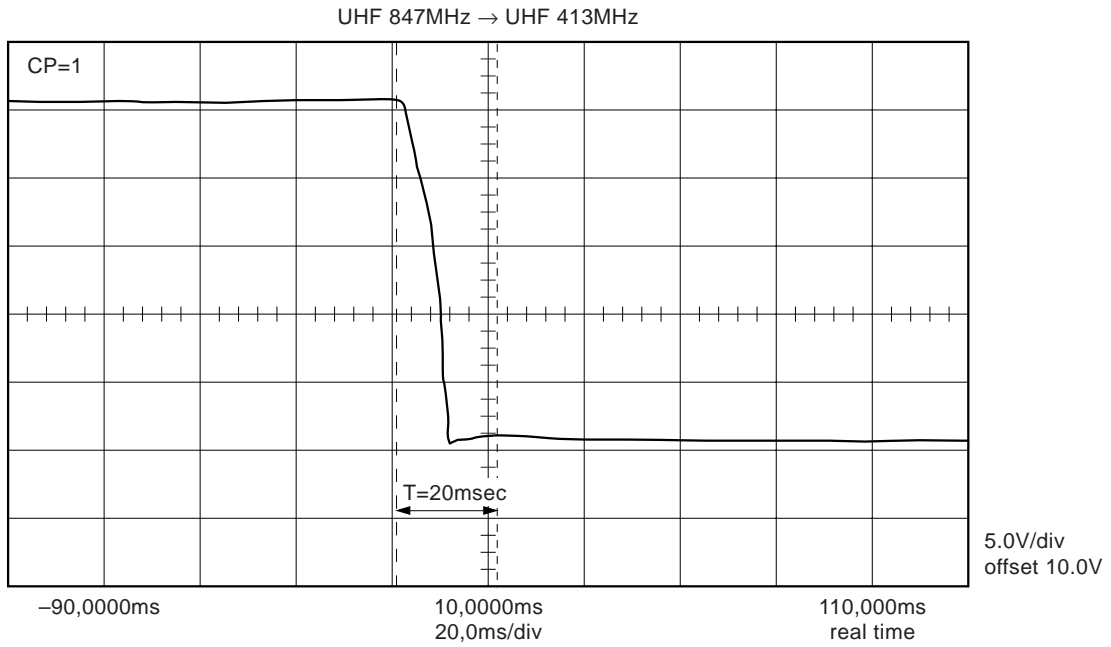

IF output spectrum

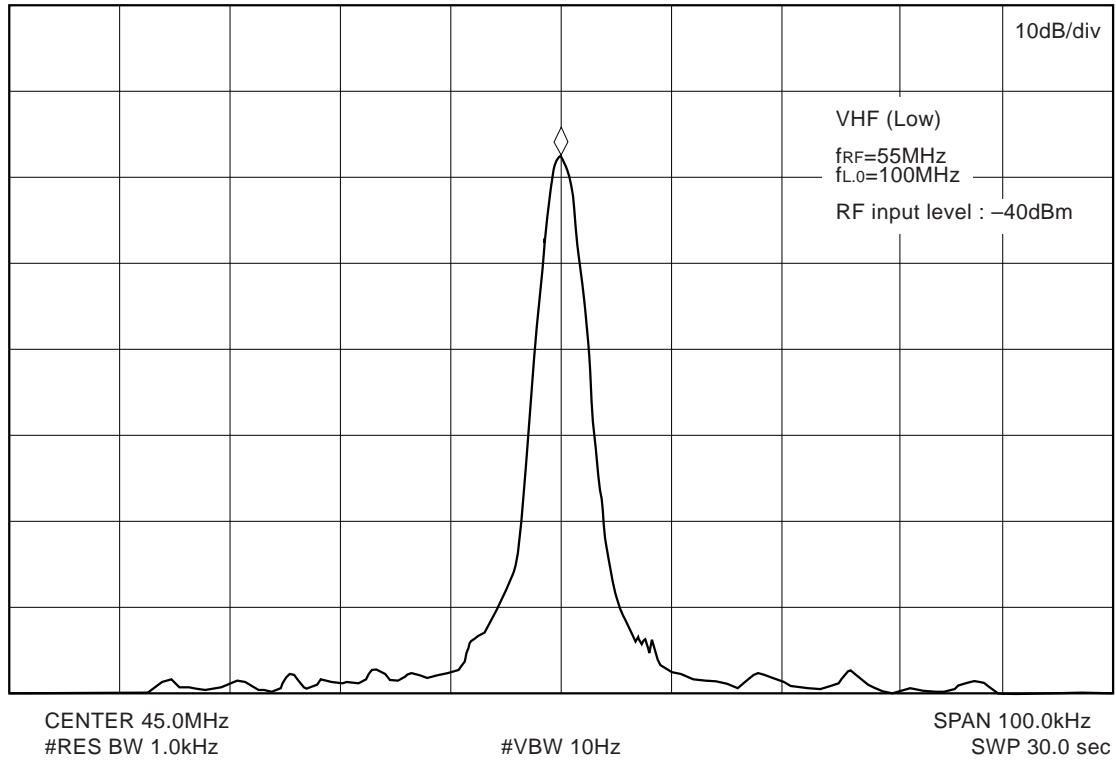

IF output spectrum

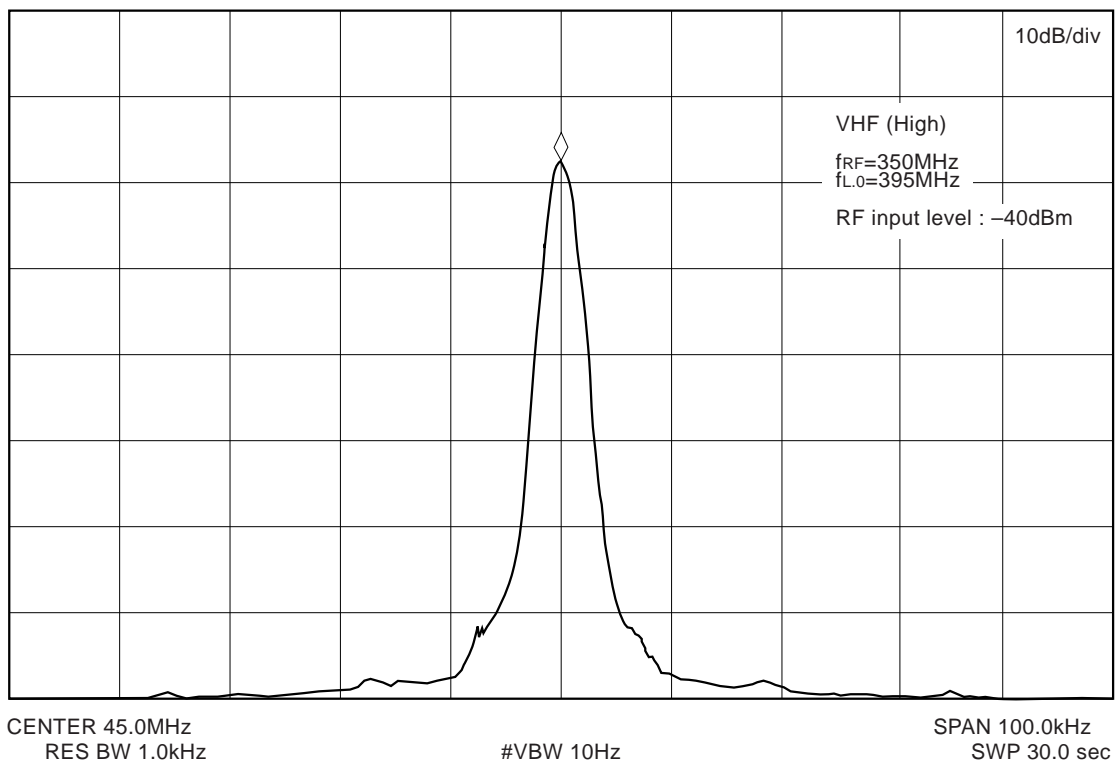

IF output spectrum

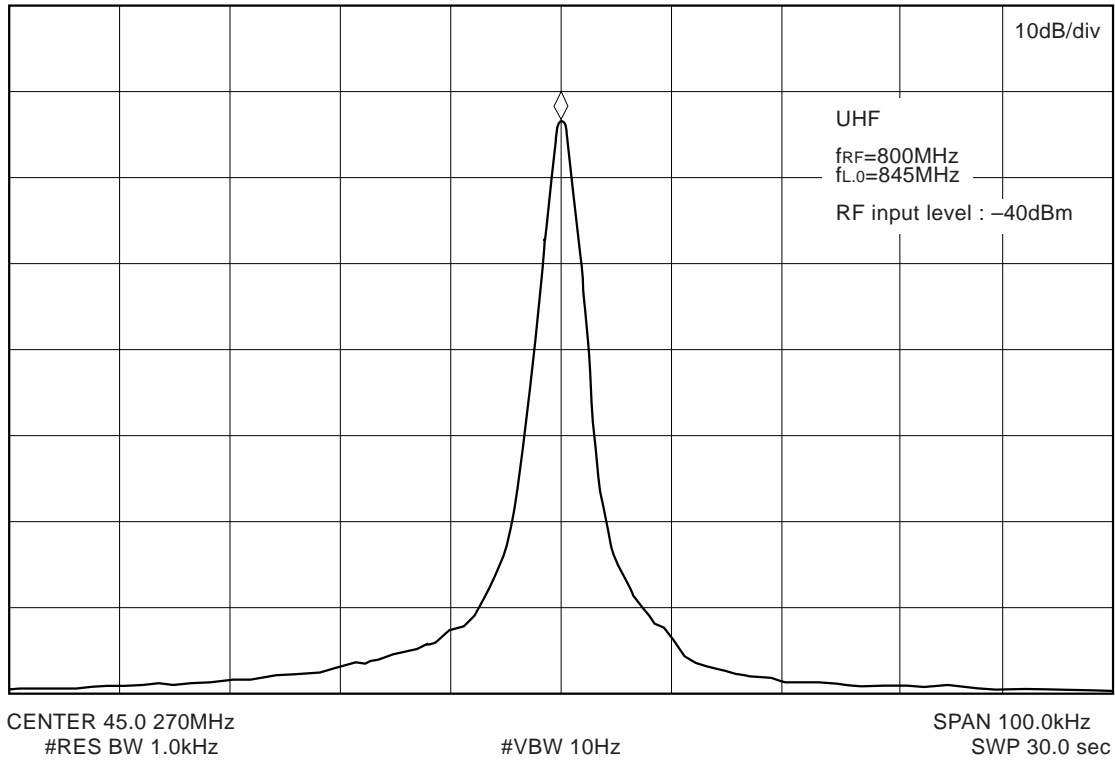

VHF Input Impedance

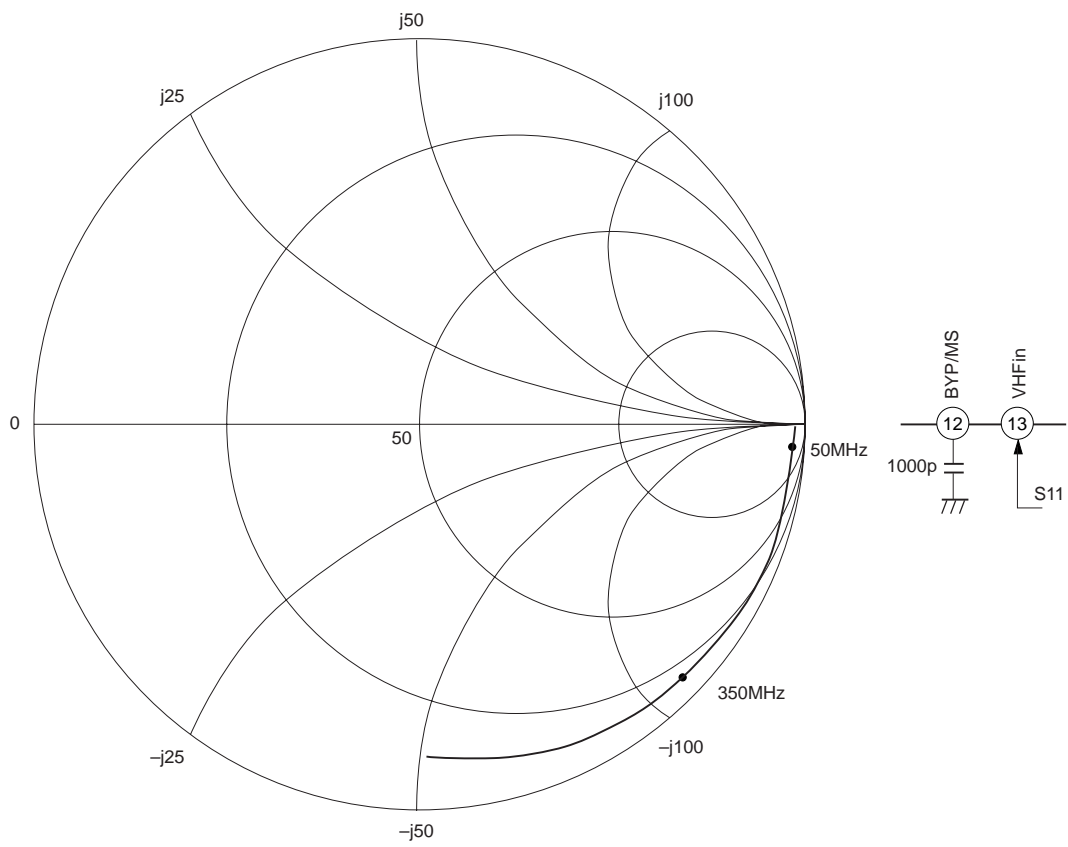

UHF Input Impedance

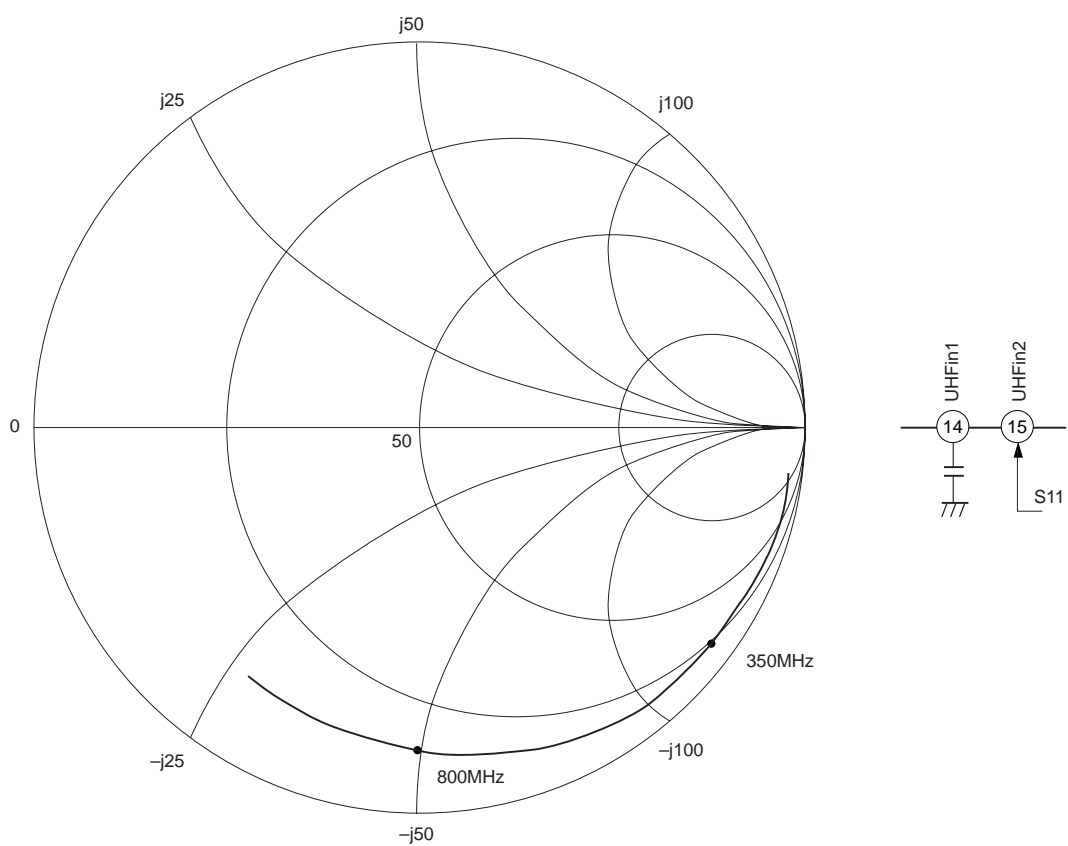

IF Output Impedance

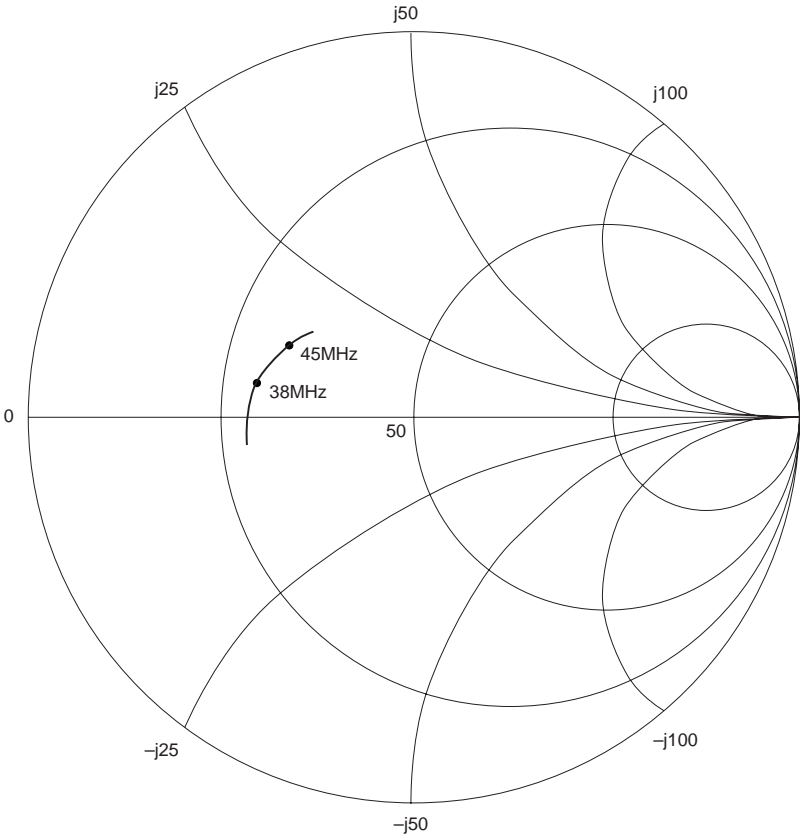

Package Outline Unit : mm

30PIN SSOP (PLASTIC)

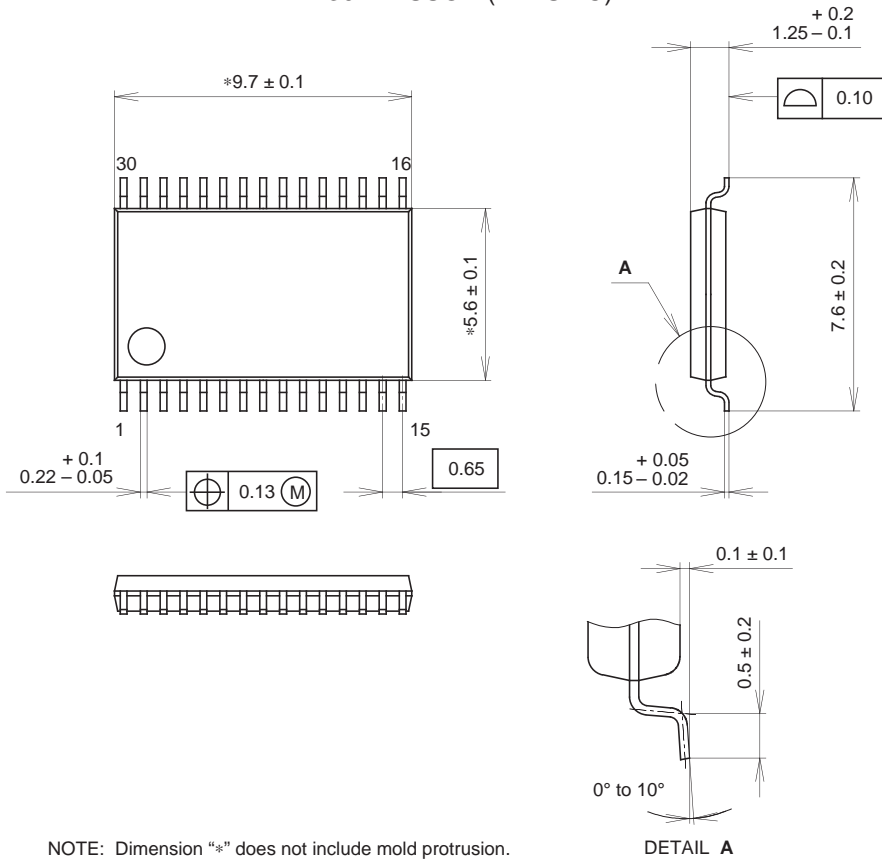

PACKAGE STRUCTURE

SONY CODE	SSOP-30P-L01
EIAJ CODE	SSOP030-P-0056
JEDEC CODE	_____

PACKAGE MATERIAL	EPOXY RESIN
LEAD TREATMENT	SOLDER/PALLADIUM PLATING
LEAD MATERIAL	42/COPPER ALLOY
PACKAGE MASS	0.1g

NOTE : PALLADIUM PLATING
 This product uses S-PdPPF (Sony Spec.-Palladium Pre-Plated Lead Frame).