

tayco®

Cosmo
installation guide

October 2019

TABLE OF CONTENTS

General Instructions **5/11**

installation checklist	5
care and maintenance	6
variable height panel combinations	7
maximum span of panels	8
installation sequence	9

Panel Frames and Connectors **12/54**

panel assembly – straight configuration	12
panel assembly – straight configuration with filler	14
panel assembly - 90° configuration	17
panel assembly – T configuration	19
panel assembly – cross configuration	21
panel assembly – 3-way, 120° configuration	23
panel assembly – 2-way, 120° configuration	25
panel assembly – L-135° configuration	27
stackable frame connection	29
stackable frame connection to stackable frame	31
stackable frame connection to door	33
stackable frame connection to door with stackable panel frame	34
door assembly – straight configuration	36
door assembly - 90°, T, cross, 120°, 135° and straight configuration	38
door with stackable frame to wall – adjustable connection	40
sliding door installation	42
panel to wall – adjustable connection	45
top trim installation panel to wall – adjustable connection	47
panel to wall – direct connection	48
panel kickplate installation	49
panel top trim & end trim installation	51
panel filler installation	54

Tiles **55/63**

panel tile installation	55
panel acrylic tile installation	58
monolithic tile removal	60
monolithic tile installation	61
surface level access door installation	63

Worksurfaces **64/68**

worksurface installation	64
slot stopper installation	65
glazed countertop installation	66
laminare countertop installation	67

Worksurface Supports **69/79**

worksurface support installation- cantilever & bracket.....	69
worksurface support installation – end gable	71
worksurface support installation – reinforcement bar	73
open metal gable installation.....	74
end gable pedestal installation.....	76
metal pedestal to metal filler bracket installation.....	78

Mounted Storage **80/84**

overhead storage installation.....	80
suspended overhead storage.....	81
cubby storage installation.....	82
top panel shared shelf installation.....	83

Accessories **85/95**

accessory bar installation.....	85
accessory organizer installation.....	87
whiteboard marker/brush tray installation.....	89
top mounted screen installation.....	90
panel top mounted glass/acrylic screen.....	91
panel top mounted glass/acrylic screen – double span.....	93

Electrics, Communication & Lighting **96/112**

electrical components and specifications.....	96
electrics/communications placement.....	97
electrical/data access and distribution.....	98
harness calculation.....	100
panel electric installation.....	104
lay-in cable installation.....	107
power pole installation.....	108
divided power pole installation.....	110
light wire management installation.....	112

Waste & Recycling **113/114**

panel with monolithic tile disposal disassembly.....	113
--	-----

for more information, contact Installation Service
toll free | 1.800.675.4092
mon-fri | 8:30am-5:00pm EST
www.tayco.com

installation checklist

Perform a site inspection prior to the installation date to check existing site conditions and identify constraints and limitations that could possibly cause delays or problems during the actual installation.

Site Accessibility

1. Verify existing loading facilities and proximity of loading dock to staging area.
2. Verify if receiving area is accessible by trailer.
3. Verify access to service elevators.
4. Reserve service elevators in advance, if necessary.

Site Preparation

1. Clear all obstacles that could interfere with the installation process.
2. When doing a reconfiguration, ensure that all furniture to be re-used are clear of computers, accessories, books, papers and all personal effects.
3. Ensure that all live wires and data/communications wires are disconnected prior to installation.

Furniture Plans

1. Labeled furniture plans for installation purposes are located in the hardware box. Ensure that drawings are complete and handy before beginning installation.

Waste Management

1. Establish a trash removal area separate from the product staging area.

care and maintenance

Fabrics

To remove dust particles, lightly vacuum the fabric surface. Spills and fluid should be immediately blotted. For minor fabric stains and marks use water-based fabric solvent, applying light pressure, to lift the dirt and stain. Any use of water and soaps may harm the fabric, causing water stains and damage to the fabric's contents. Do not scrub the fabric with bristle or vacuum brushes as the fabric may pill or tear and the appearance may be permanently affected. Professional steam cleaning is recommended.

Laminates

Dust laminated surfaces for regular maintenance. Clean any dirt or stain with a damp cloth. Do not use an excessive amount of water, abrasive cleaners, acids or alkalis and do not scratch or scrape surfaces. For persistent stains and marks use a commercial cleaner, such as Cabinet Magic® or Countertop Magic®, both manufactured by Magic American Corporation.

Acrylic

Dust regularly to keep surfaces free of dust particles. Clean any dirt with a damp cloth. Dry the area using a dry paper cloth. The use of fiber cloths or rags is not recommended as loose particles and debris remaining on the cloth may scratch or harm the acrylic surface. Do not use other chemical cleaners or window cleaners as their chemical compositions may alter and/or permanently affect the surface appearance.

Painted Metals

Tayco's painted metal products are powder-paint-coated. To clean these products, use a damp cloth, using only a small amount of lukewarm water if necessary. Dry with a clean, dry cloth. To avoid scratching and damaging the painted surface, do not use hard bristled brushes or abrasives.

***THE USE OF HARSH CLEANERS AND CHEMICALS MAY PERMANENTLY ALTER THE PRODUCT FINISH APPEARANCE AND WILL VOID ANY WARRANTY.**

variable height panel combinations

Cosmopolitan offers the flexibility of 90, 180, 120, and 135 degree connections at varying heights. Illustrated below are a few connection possibilities for Cosmopolitan panel frames.

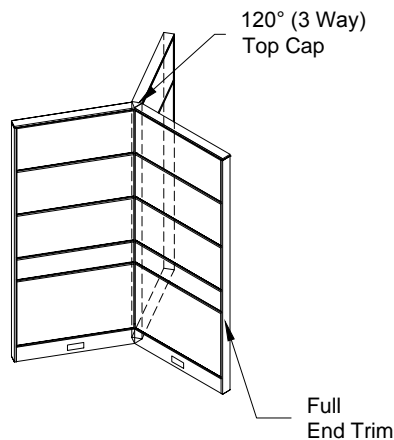
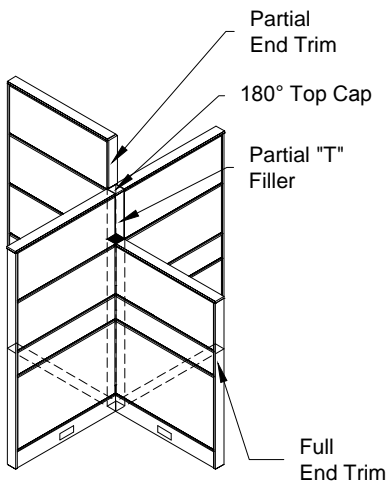
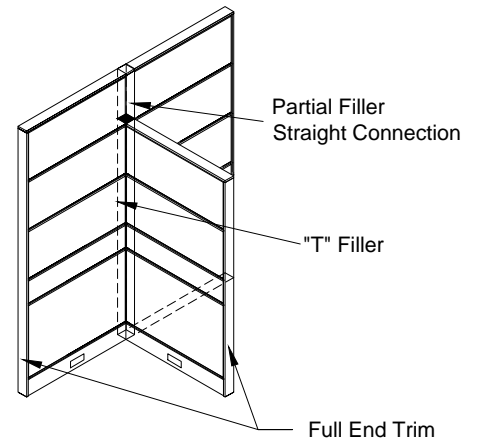
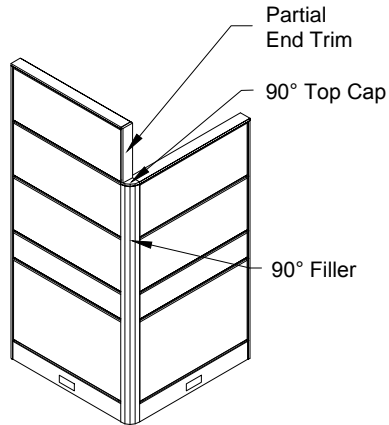
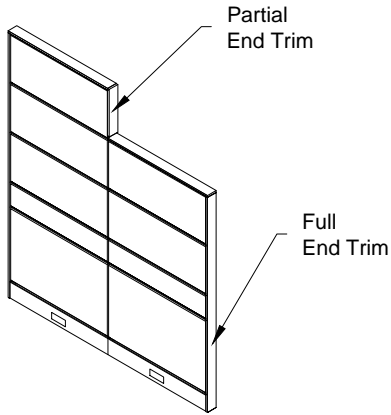

Note:
Always same height panels.

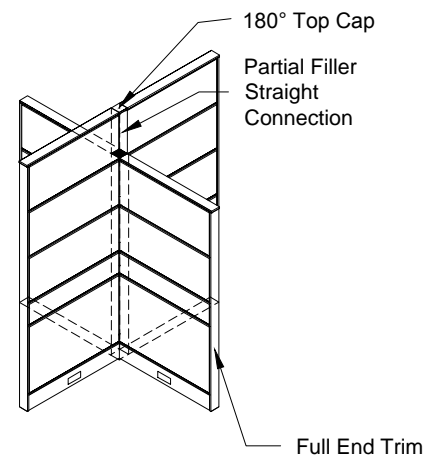
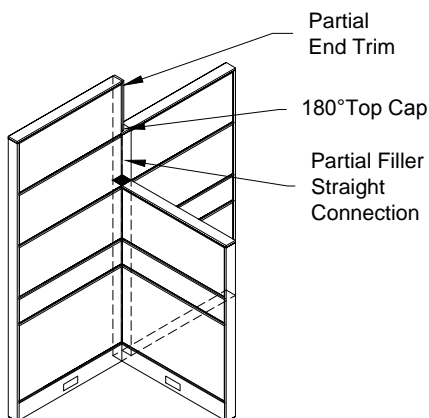
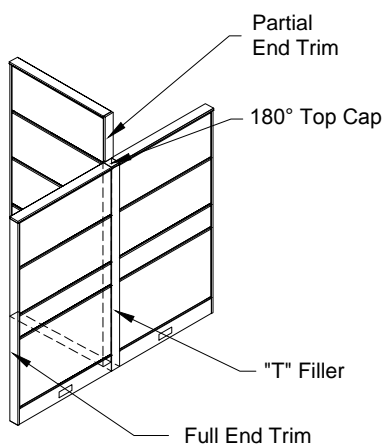
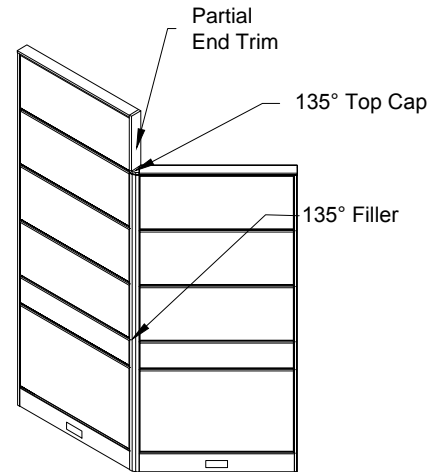

maximum span of panels

When specifying Cosmopolitan, it is important to be mindful of the width that the panels are required to span. The following examples illustrate the maximum width that panels can span before they need to be supported by a return panel or wall.

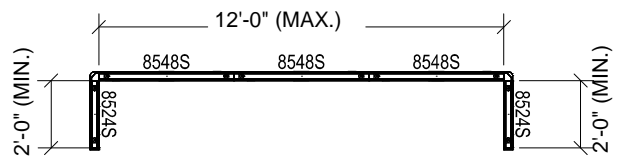
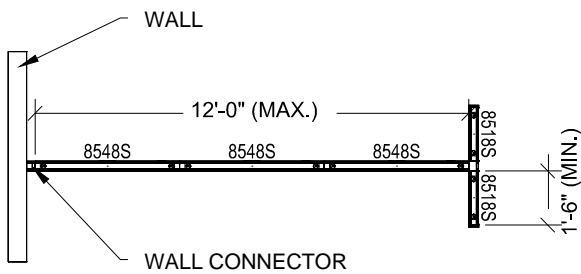
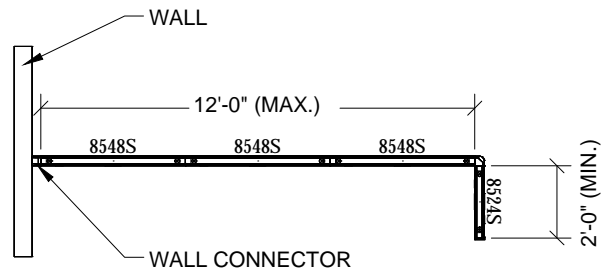
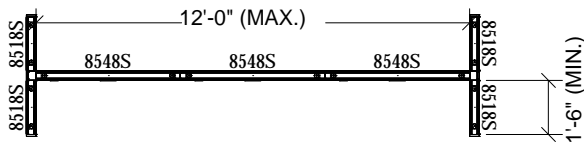
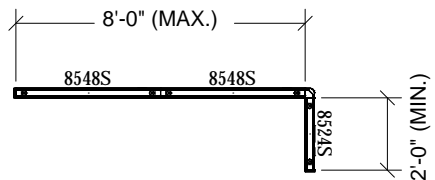
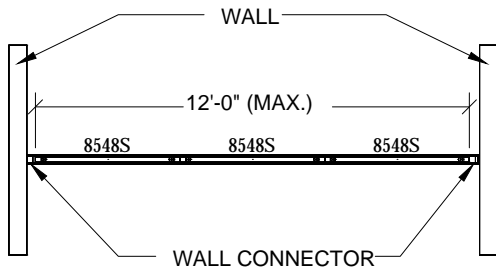
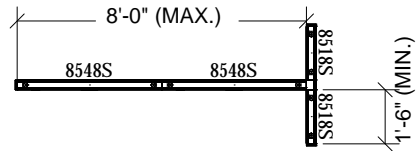
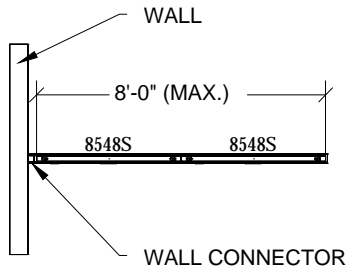

installation sequence

1. Remove all the tiles on one side of each panel.
2. Install panel electrics.
3. Re-install tiles previously removed; install raceways.

STEP 1

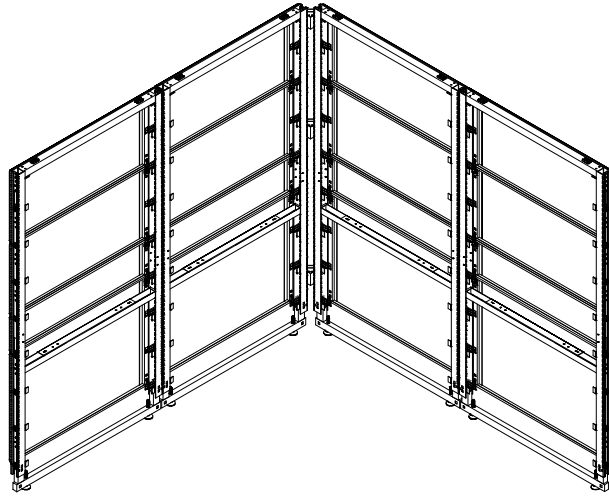

STEP 2

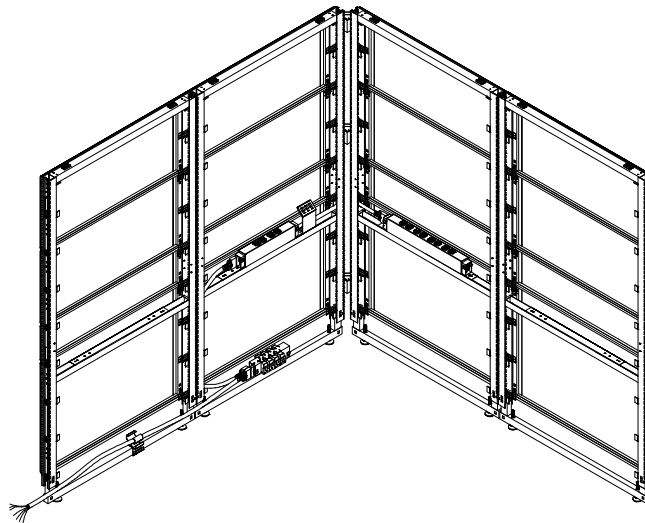

STEP 3

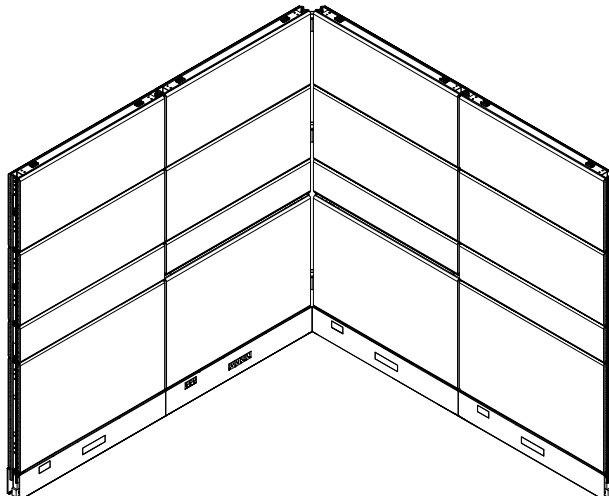

installation sequence (cont'd)

4. Install panel trims, top caps and fillers.
5. Install surface supports.
6. Install overhead storage units. Attach task lights to underside of overhead storage units.

STEP 4

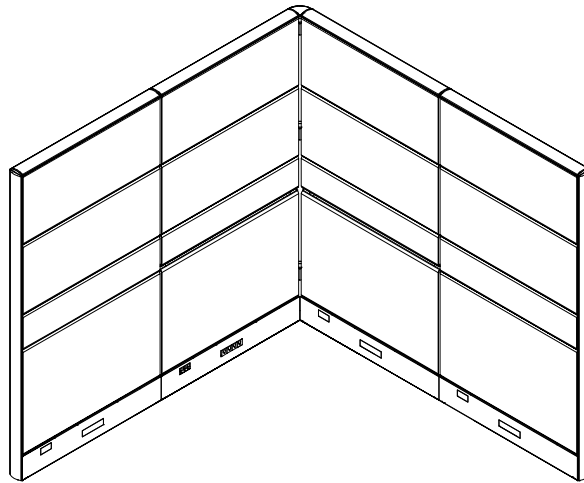

STEP 5

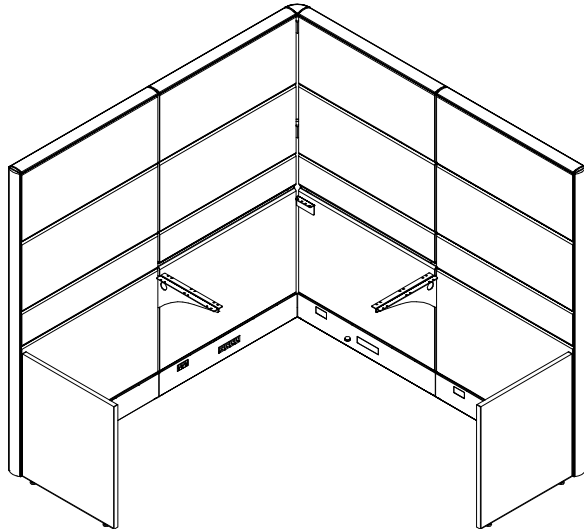

STEP 6

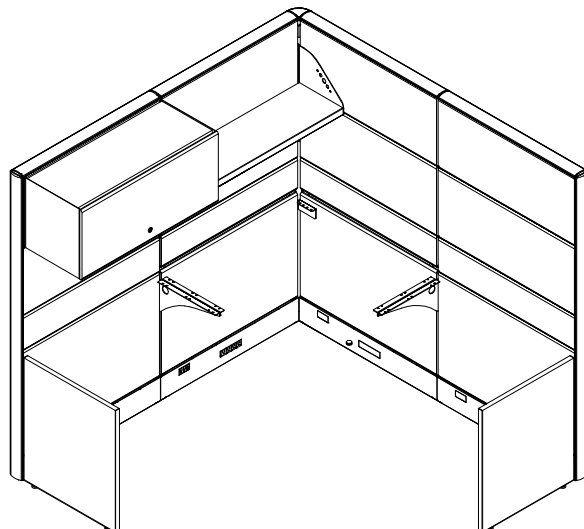

installation sequence (cont'd)

7. Install surfaces and keyboard trays.
8. Install under desk storage units.
9. Install accessory bars, accessories and CPU holders.

STEP 7

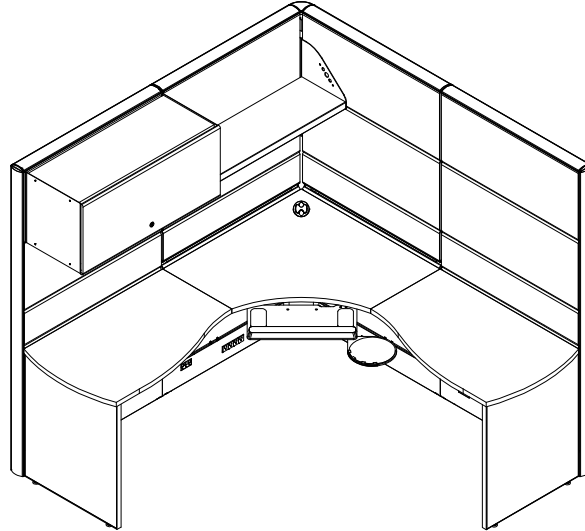

STEP 8

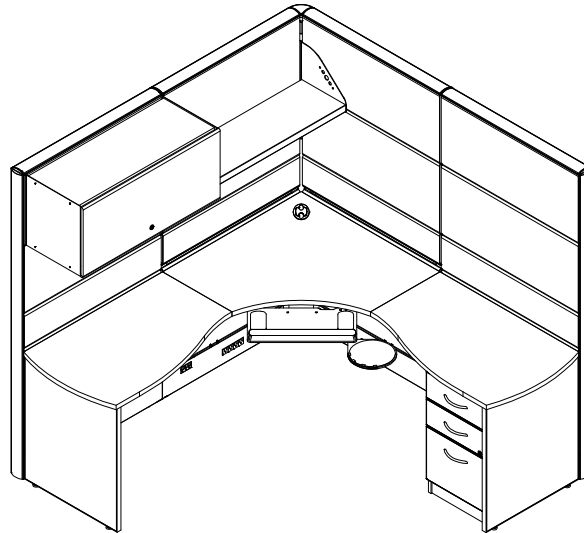

STEP 9

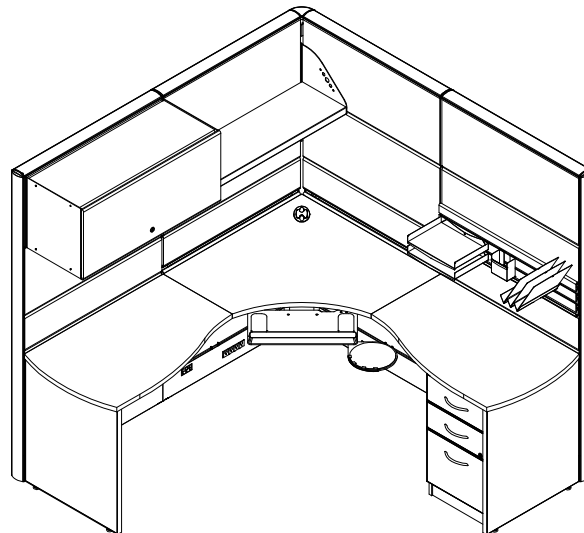

panel assembly - straight configuration

1. Line up two panels, (Figure 1).
2. Level off panels (use the torpedo level) by adjusting the glides, (Figure 2).
3. Remove the tiles on one side of the panel, (Figure 3).

FIGURE 1

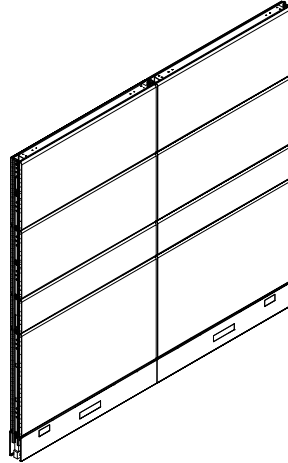

FIGURE 2

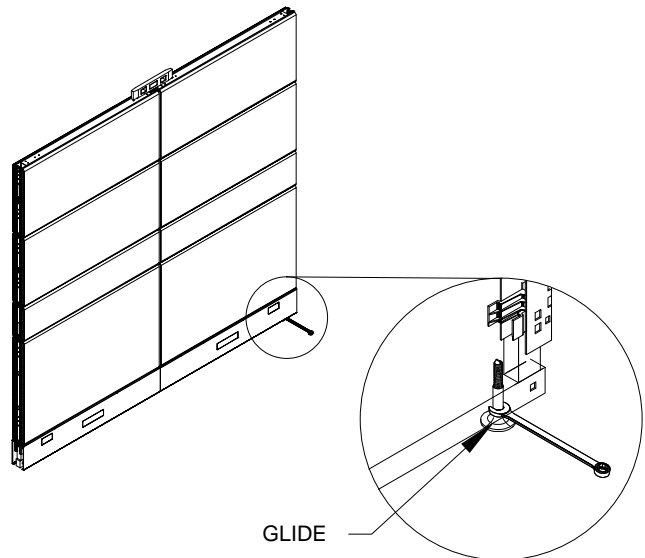
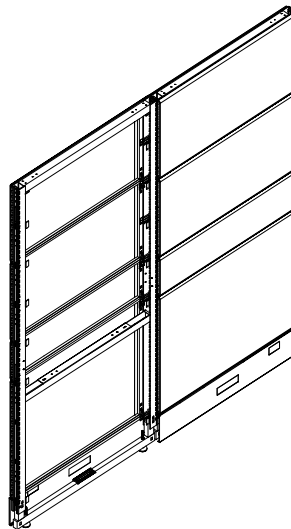
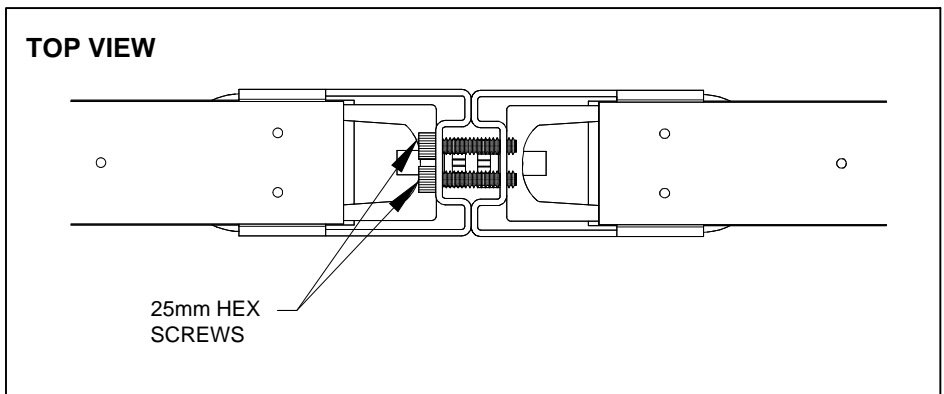
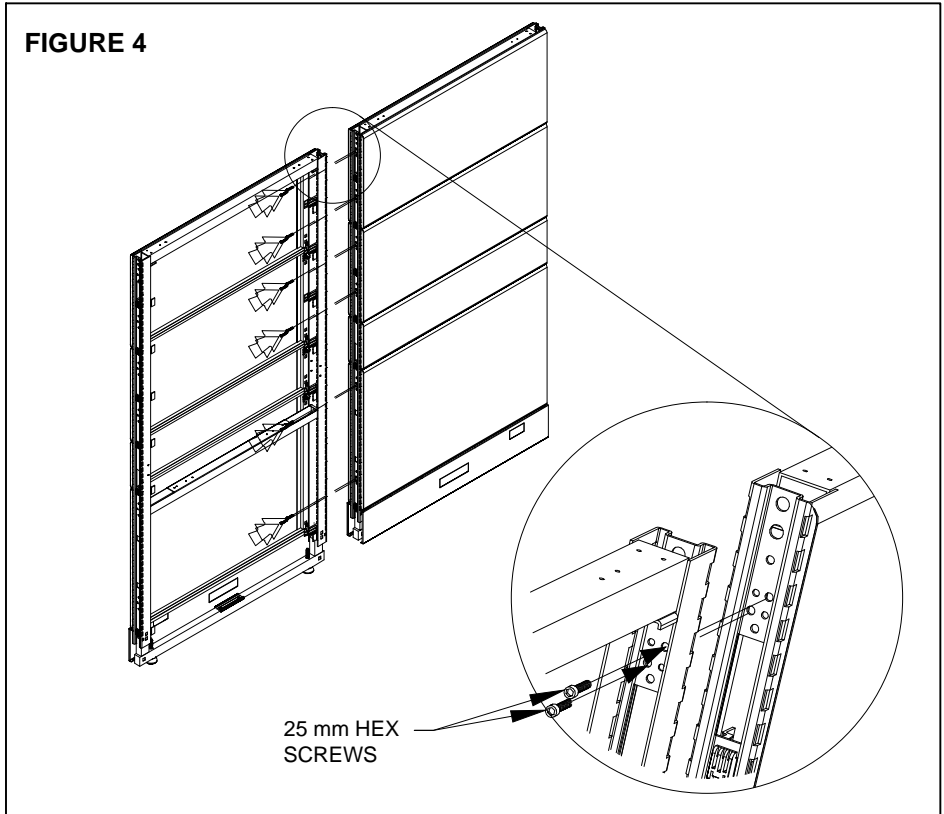

FIGURE 3



panel assembly - straight configuration (cont'd)

4. Using a 6-inches hex key, install the 25 mm or 1-inch hex screws staggered on the inside of the panel, (Figure 4).
5. Re-install the tile previously removed, if there is no panel to install next to it.



hardware needed

panel height (inches)	37	45	53	61	69	77	85
25mm hex screw	6X	6X	8X	10X	12X	14X	16X



NOTE:

- > Do not re-install the tiles right away, might need them off to install next frames.

tools needed

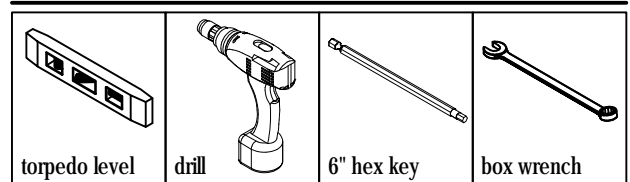

panel assembly - straight configuration w/ filler

1. Line up two panels, (Figure 1).
2. Level off panels (use the torpedo level) by adjusting the glides, (Figure 2).

FIGURE 1

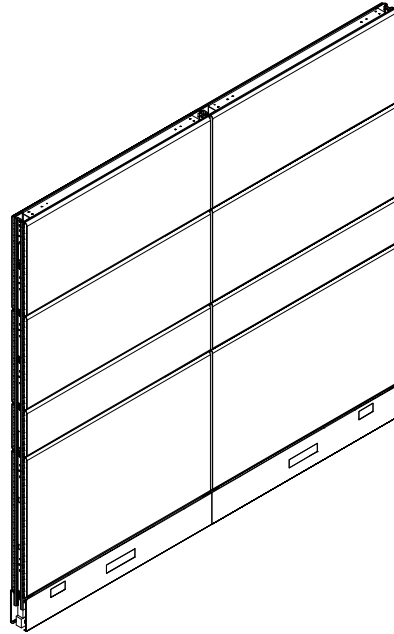
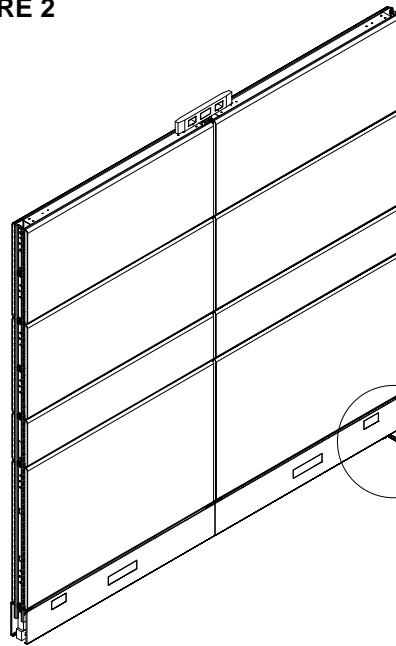

FIGURE 2



GLIDE

panel assembly - straight configuration w/ filler (cont'd)

3. Remove the tiles on one side of each panel.
4. Insert straight connectors between the two panels.
5. Using a 6-inch hex key, install the 25 mm or 1-inch hex screws into the inside edge of the panel frame; this will protrude into the STRAIGHT CONNECTORS, (Figure 3).

FIGURE 3

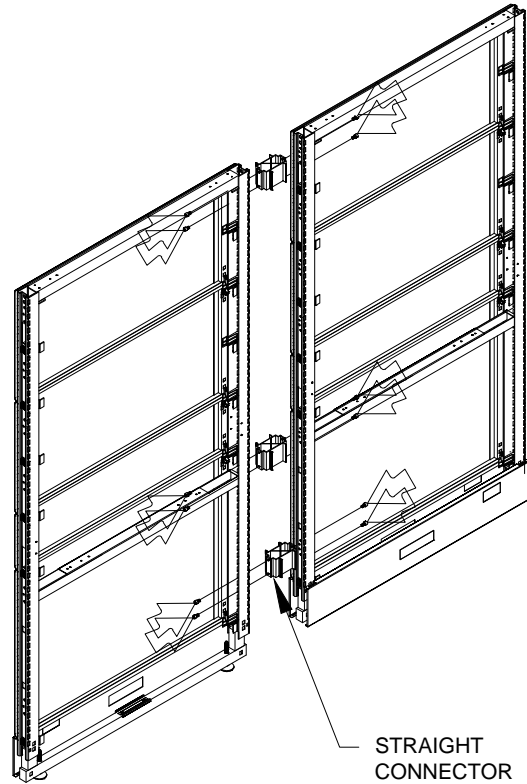

TOP VIEW

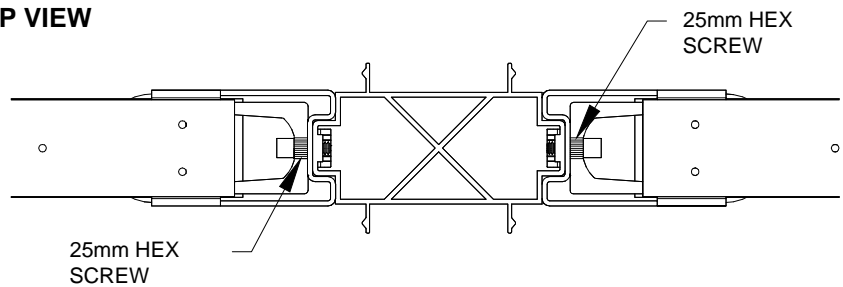

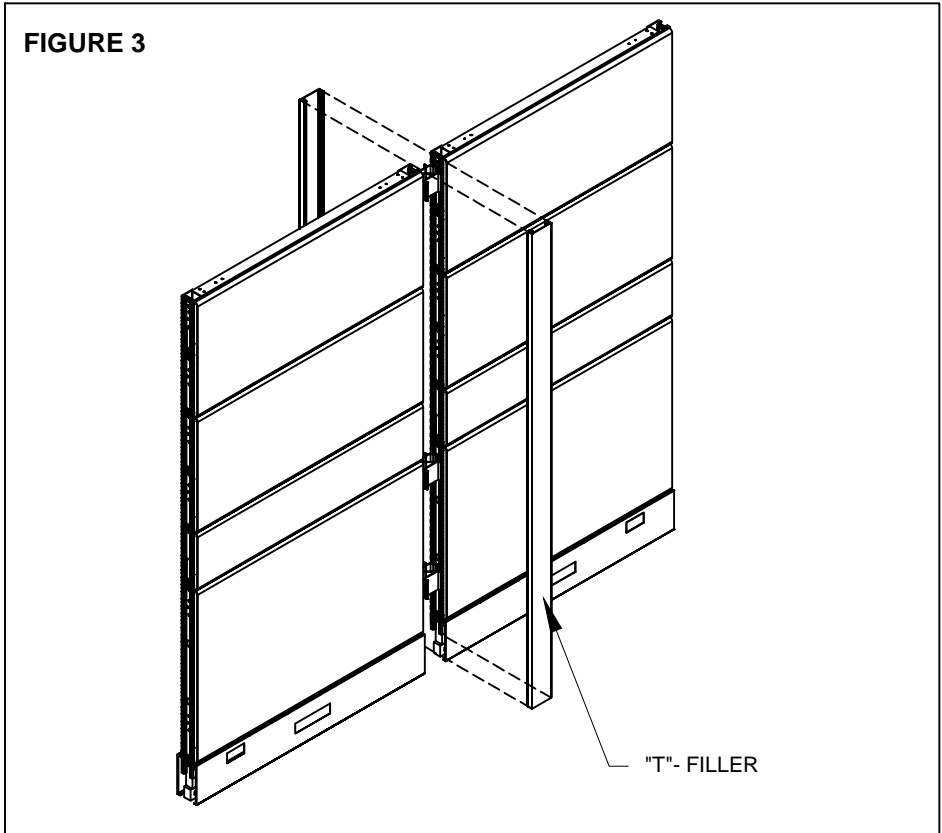

panel assembly - straight configuration w/ filler (cont'd)

6. Re-install the tiles previously removed, if there is no panel to install next to it.
7. Attach the "T"-fillers to the junction of the panels, (Figure 4).



hardware needed

panel height (inches)	37	45	53	61	69	77	85
straight connector 	2X	3X	3X	3X	3X	3X	4X
25mm hex screw 	8X	12X	12X	12X	12X	12X	18X

NOTE:

- > Do not re-install the tiles right away, might need them off to install next frames.

tools needed

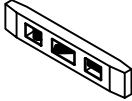
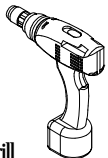
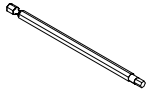
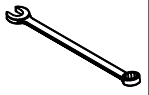
			
torpedo level	drill	6" hex key	box wrench

panel assembly - 90° configuration

1. Line up two panels, (Figure 1).
2. Level off panels (use the torpedo level) by adjusting the glides, (Figure 2).

FIGURE 1

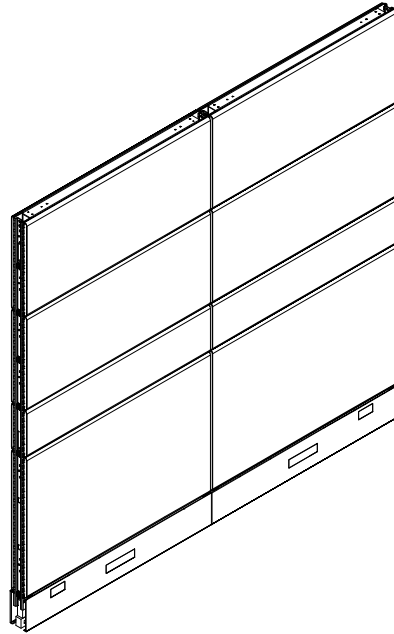
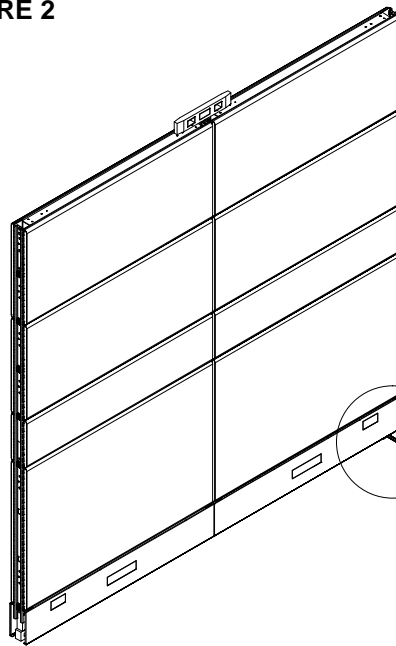

FIGURE 2



GLIDE

panel assembly - 90° configuration (cont'd)

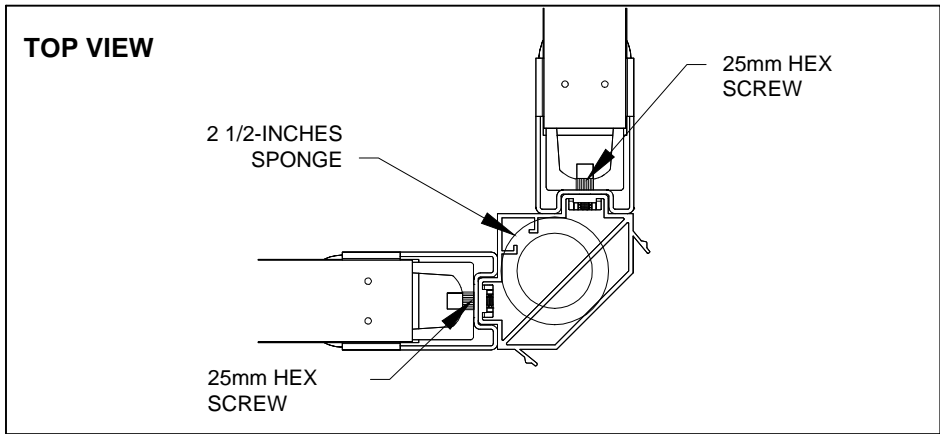
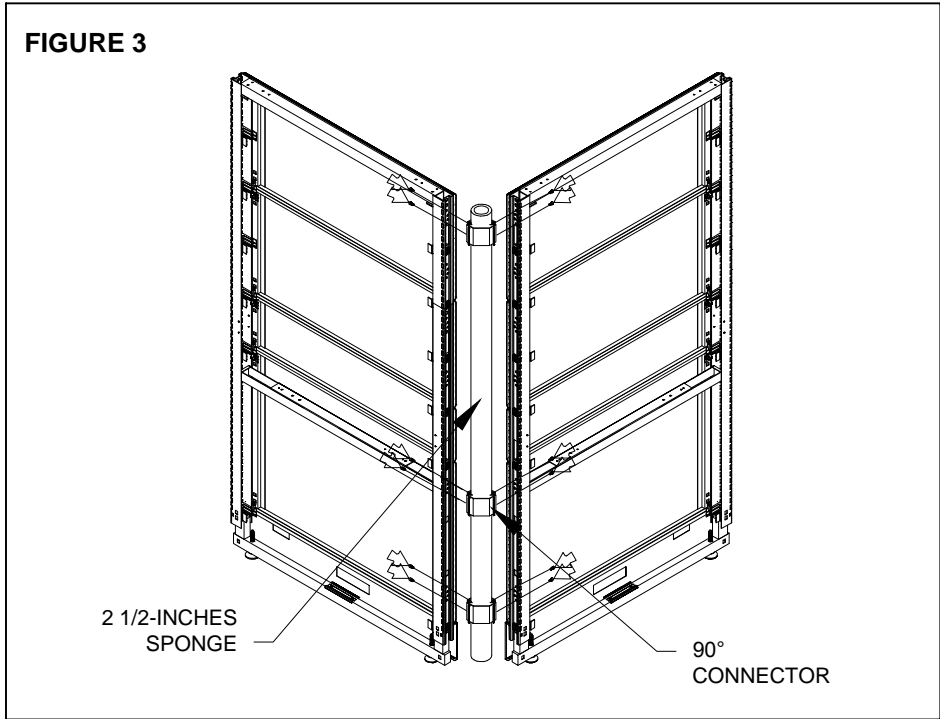

3. Remove the tiles on one side of each panel.
4. Rotate one panel to create a 90-degree angle.
5. Using a 6-inches hex key, install the 25 mm or 1-inch hex screws into the inside edge of the panels; this will protrude into the L-90 CONNECTORS, (Figure 3).
6. Insert a piece of 2.5-inches diameter sponge vertically, so that light will not protrude through, (Figure 3).
7. Re-install the tiles previously removed, if there is no panel to install next to it.



NOTES:

- > Do not re-install the tiles right away, might need them off to install next frames.
- > Sponge to be inserted before last panel is installed.

hardware needed

panel height (inches)	37	45	53	61	69	77	85
L-90 connector 	2X	3X	3X	3X	3X	3X	4X
25mm hex screw 	8X	12X	12X	12X	12X	12X	16X

tools needed

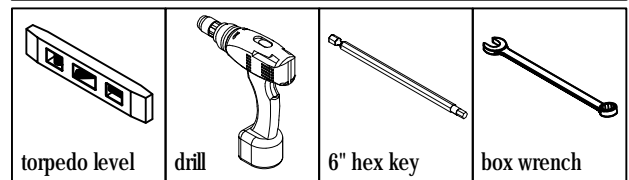

panel assembly - "T" configuration

1. Line up two panels, (Figure 1).
2. Level off panels (use the torpedo level) by adjusting the glides, (Figure 2).

FIGURE 1

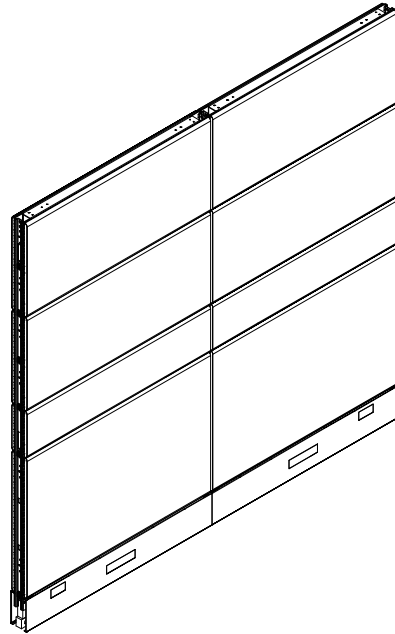
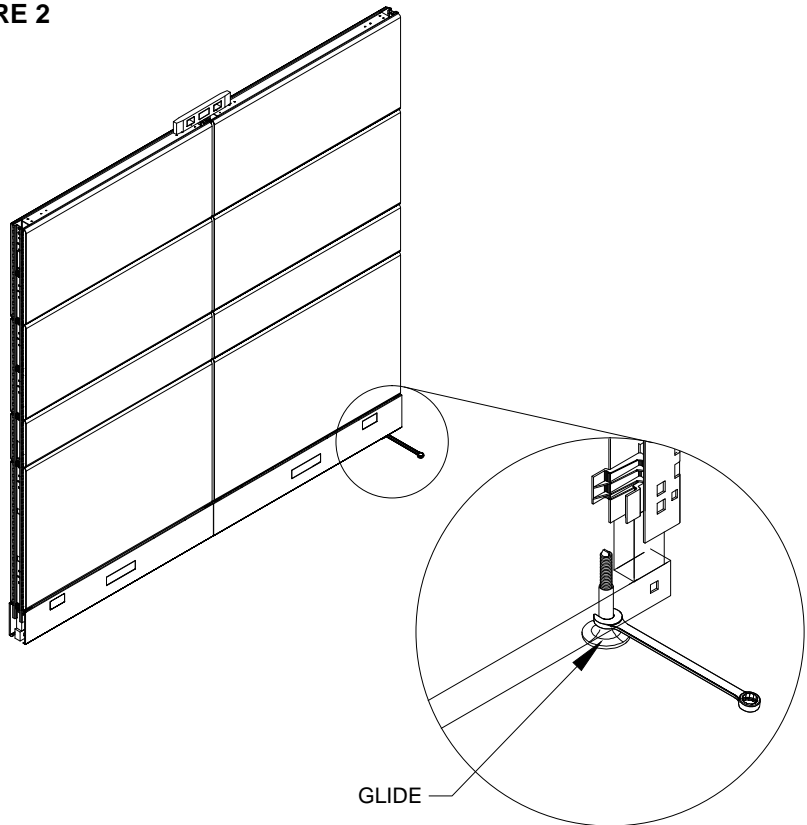
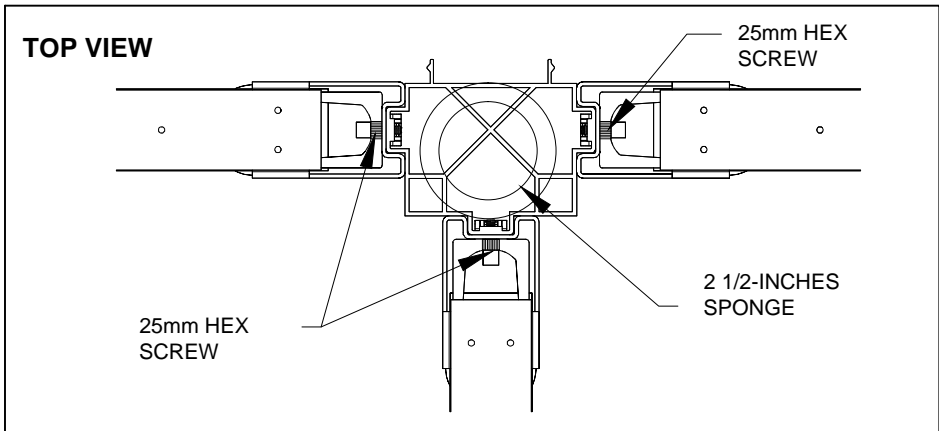
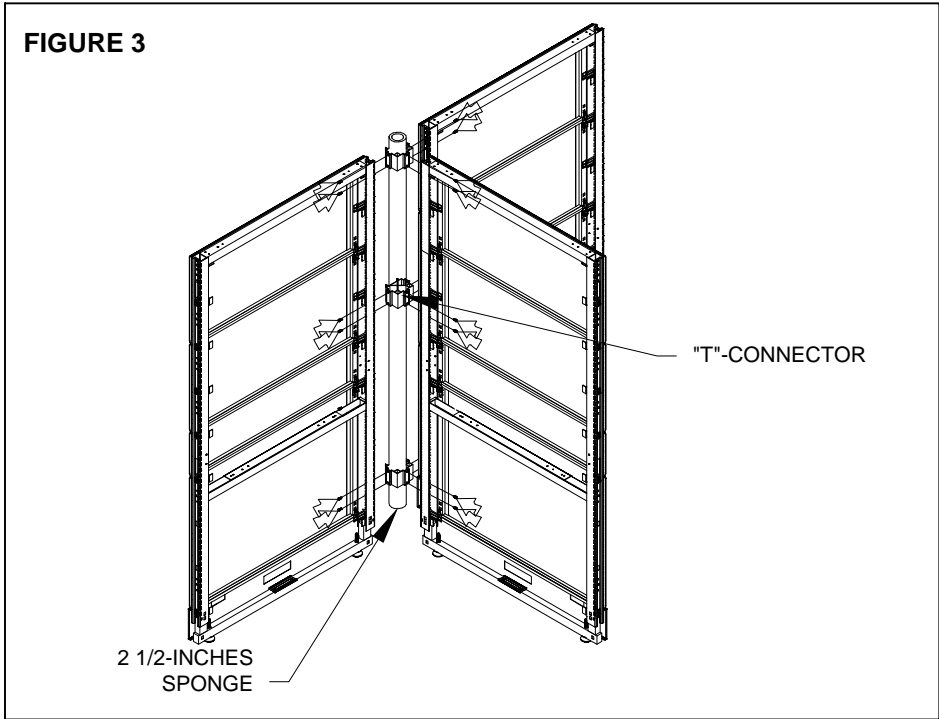

FIGURE 2



panel assembly - "T" configuration (cont'd)



3. Remove the tiles on one side of each panel.
4. Rotate one panel to create a 90-degree angle.
5. Using a 6-inches hex key, install the 25 mm or 1-inch hex screws into the inside edge of the panels; this will protrude into the "T"-CONNECTORS, (Figure 3).
6. For the third panel follow the same procedures as stated above.
7. Insert between connectors pieces of 2 1/2-inches diameter sponge vertically, so that light will not protrude through, (Figure 3).
8. Re-install the tiles previously removed, if there is no panel to install next to it.



NOTES:

- > Do not re-install the tiles right away, might need them off to install next frames.
- > Sponge to be inserted before last panel is installed.

hardware needed

panel height (inches)	37	45	53	61	69	77	85
T connector 	2X	3X	3X	3X	3X	3X	4X
25mm hex screw 	12X	18X	18X	18X	18X	18X	24X

tools needed

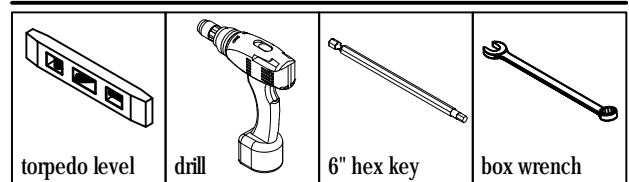

panel assembly - cross configuration

1. Line up two panels, (Figure 1).
2. Level off panels (use the torpedo level) by adjusting the glides, (Figure 2).

FIGURE 1

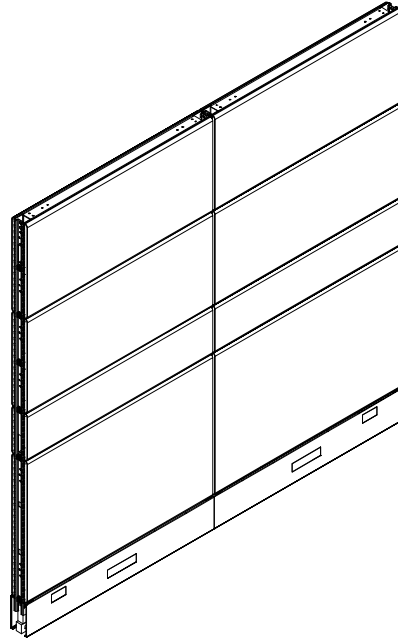
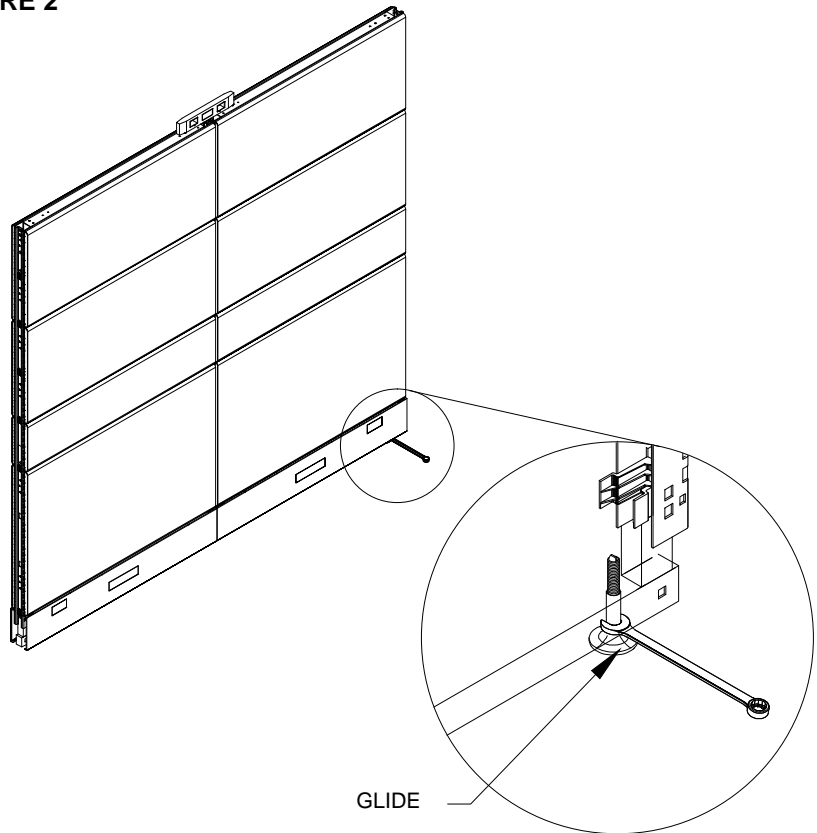
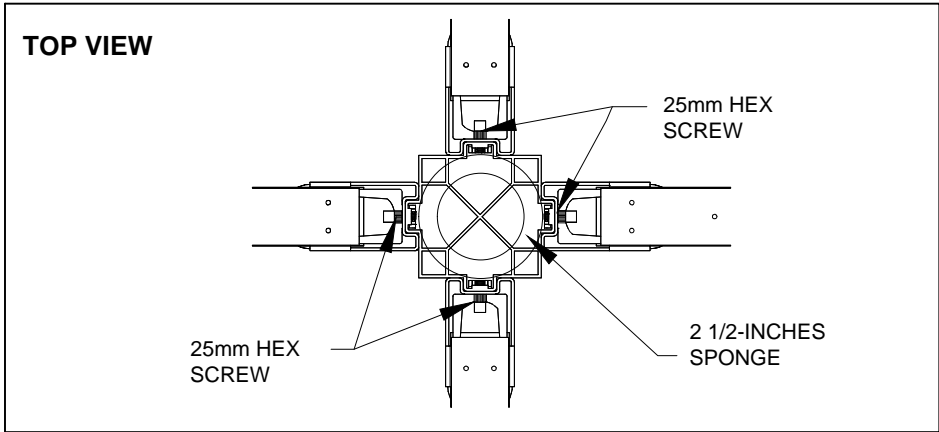
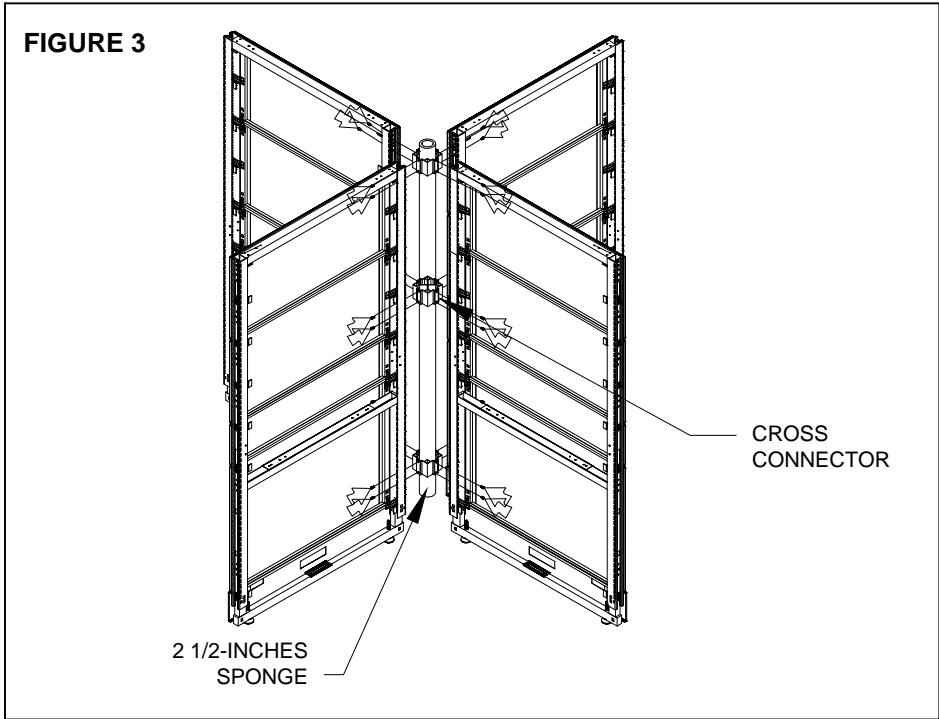

FIGURE 2



panel assembly - cross configuration (cont'd)



3. Remove the tiles on one side of each panel.
4. Rotate one panel to create a 90-degree angle.
5. Using a 6-inches hex key, install the 25 mm or 1-inch hex screws into the inside edge of the panels; this will protrude into the CROSS CONNECTORS, (Figure 3).
6. For the third and fourth panels, follow the same procedures as stated above.
7. Insert a piece of 2 1/2-inches diameter sponge vertically, so that light will not protrude through, (Figure 3).
8. Re-install the tiles previously removed, if there is no panel to install next to it.



NOTES:

- > Do not re-install the tiles right away, might need them off to install next frames.
- > Sponge to be inserted before last panel is installed.

hardware needed

panel height (inches)	37	45	53	61	69	77	85
cross connector 	2X	3X	3X	3X	3X	3X	4X
25mm hex screw 	16X	24X	24X	24X	24X	24X	32X

tools needed

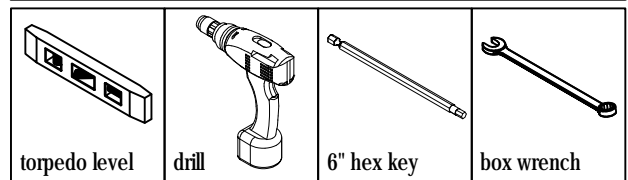

panel assembly - 3 way, 120° configuration

1. Line up two panels, (Figure 1).
2. Level off panels (use the torpedo level) by adjusting the glides, (Figure 2).

FIGURE 1

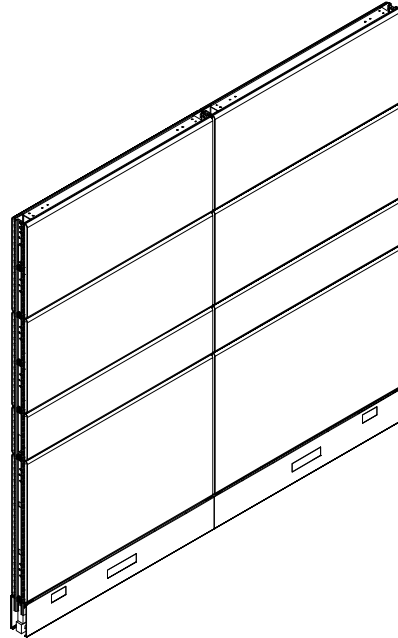
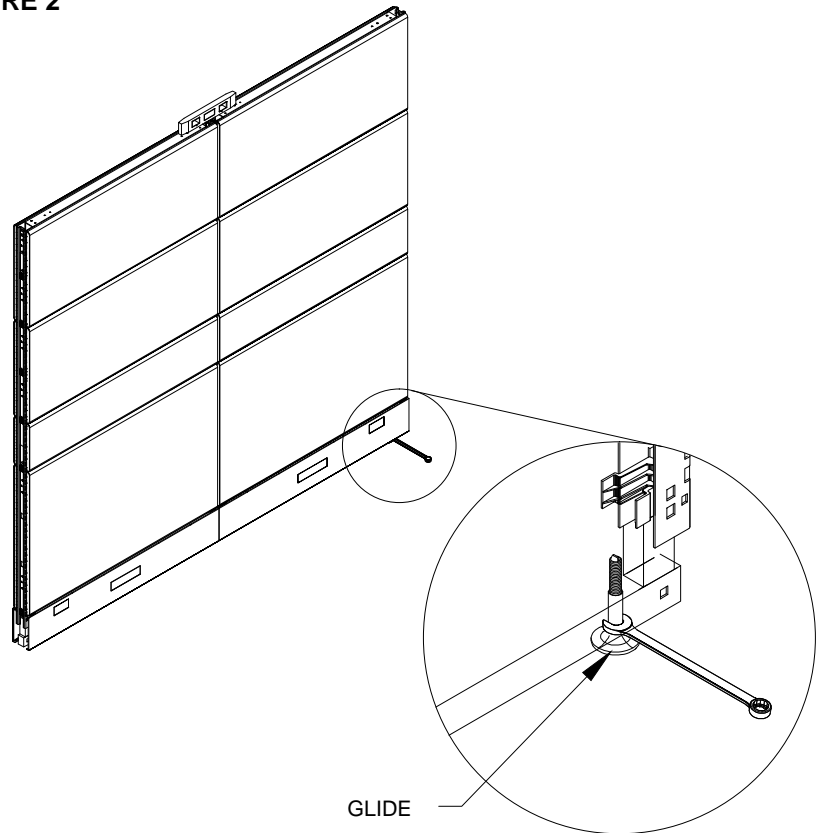
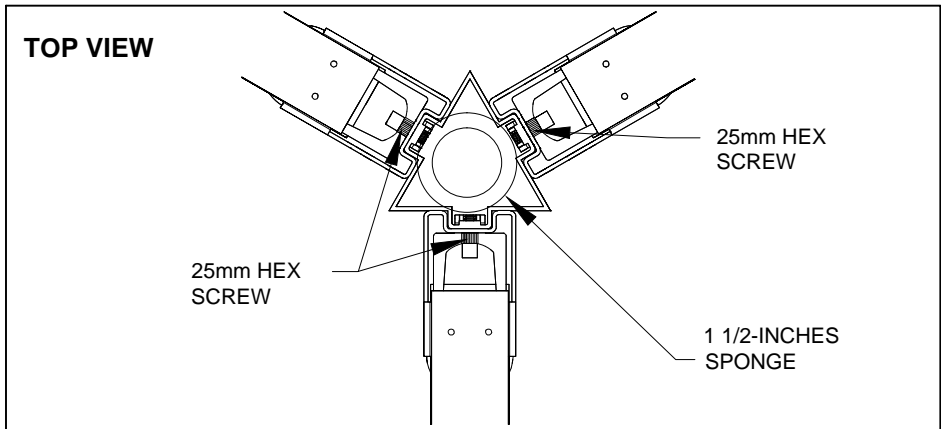
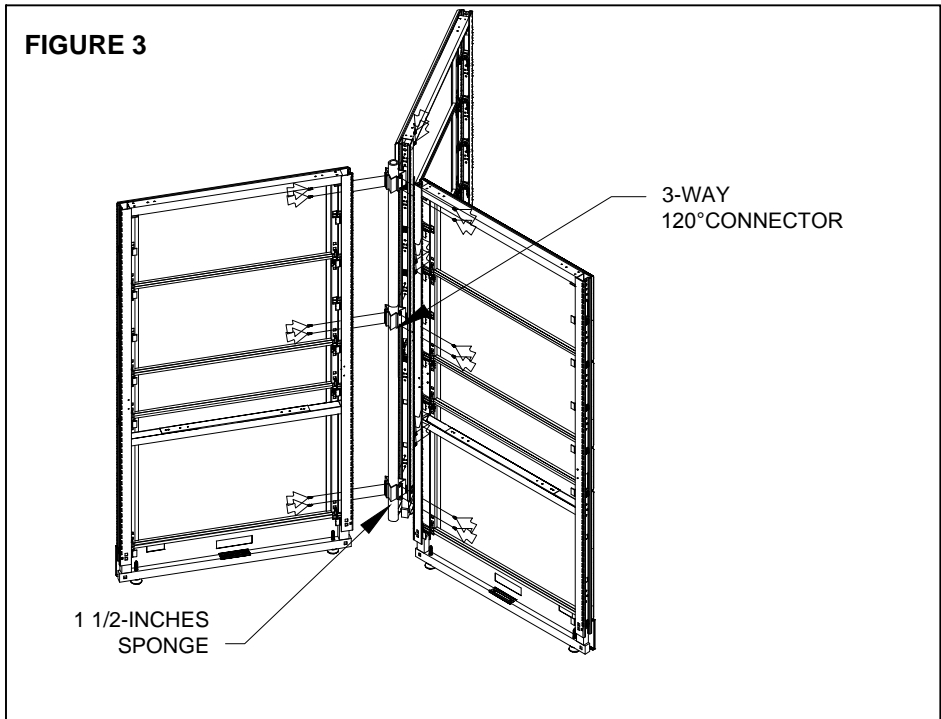

FIGURE 2



panel assembly - 3 way, 120° configuration (cont'd)



3. Remove all the tiles on one side of each panel.
4. Rotate one panel to create a 120-degree angle.
5. Using a 6-inches hex key, install the 25 mm or 1-inch hex screws into the inside edge of the panel frame; this will protrude into the 3-WAY 120 CONNECTORS, (Figure 3).
6. For the third panel follow the same procedures as stated above.
7. Insert a piece of 1 1/2-inches diameter sponge vertically so that light will not protrude through, (Figure 3).
8. Re-install the tiles previously removed, if there is no panel to install next to it.



NOTES:

- > Do not re-install the tiles right away, might need them off to install next frames.
- > Sponge to be inserted before last panel is installed.

hardware needed

panel height (inches)	37	45	53	61	69	77	85
3 way, 120 connector 	2X	3X	3X	3X	3X	3X	4X
25mm hex screw 	12X	18X	18X	18X	18X	18X	24X

tools needed

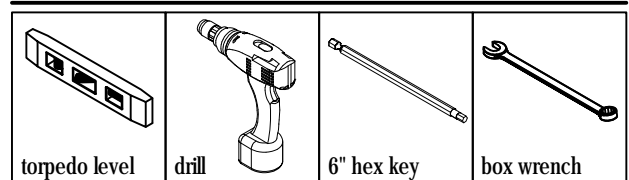

panel assembly - 2 way, 120° configuration

1. Line up two panels, (Figure 1).
2. Level off panels (use the torpedo level) by adjusting the glides, (Figure 2).

FIGURE 1

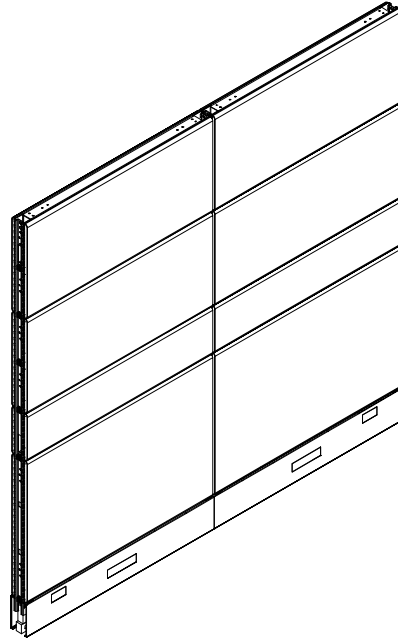
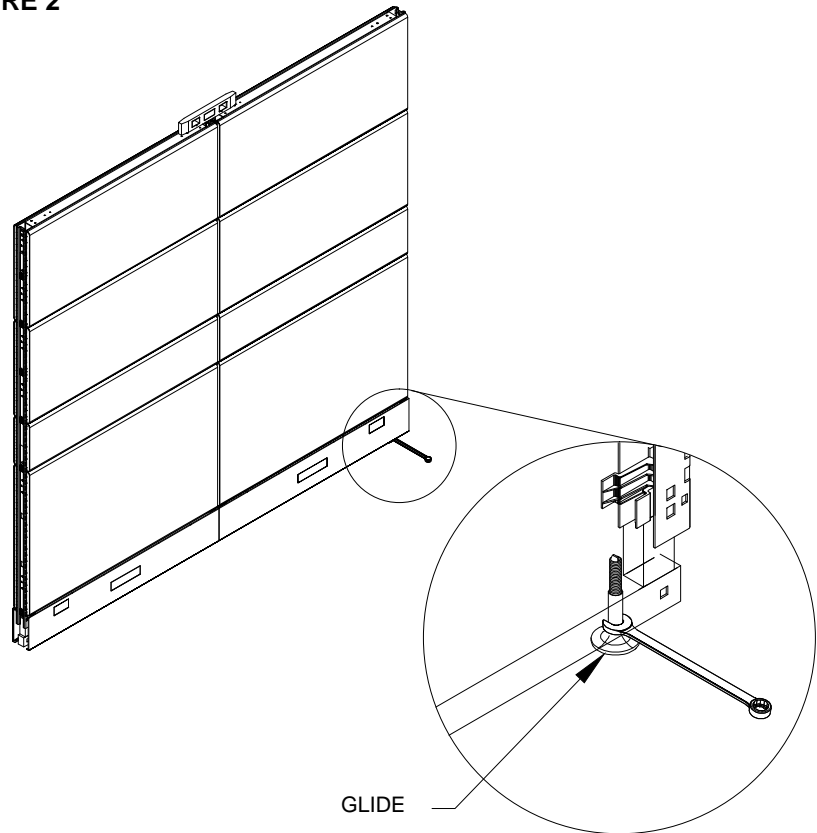
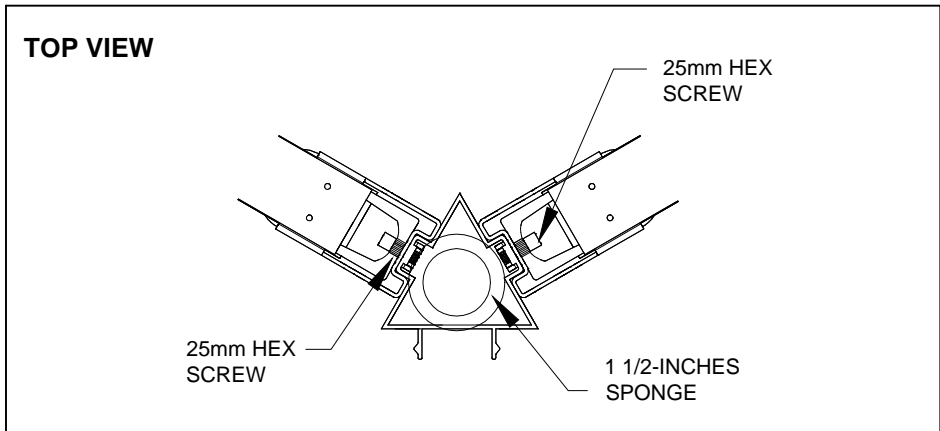
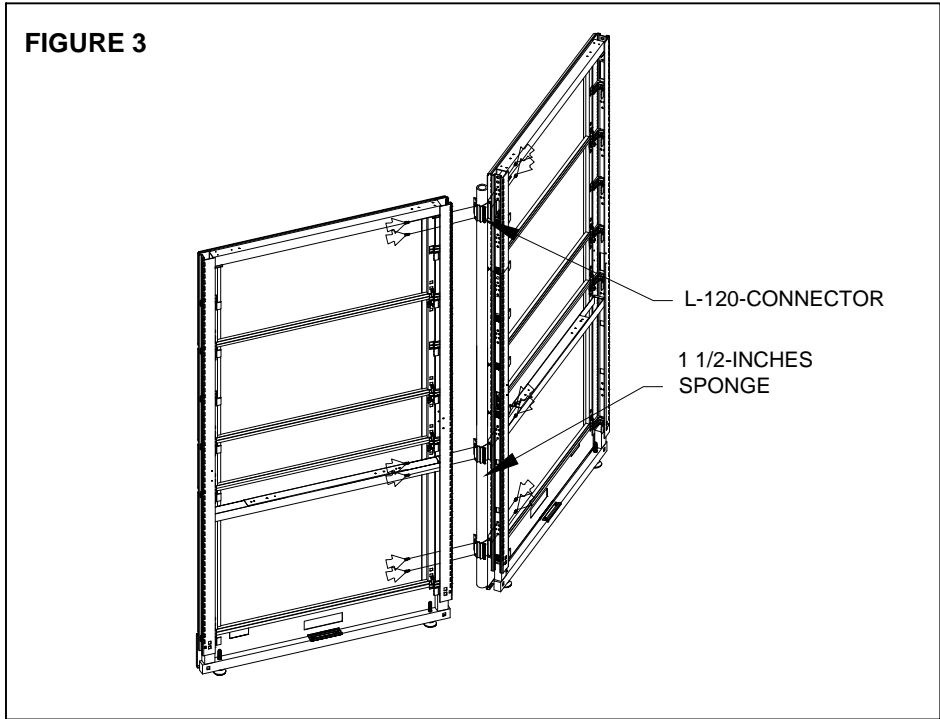

FIGURE 2



panel assembly - 2 way, 120° configuration (cont'd)



3. Remove all the tiles on one side of each panel.
4. Rotate one panel to create a 120-degree angle.
5. Using a 6-inches hex key, install the 25 mm or 1-inch hex screws into the inside edge of the panel frame; this will protrude into the 2 way 120 CONNECTORS, (Figure 3).
6. Insert a piece of 1 1/2-inches diameter sponge vertically so that light will not protrude through, (Figure 3).
7. Re-install the tiles previously removed, if there is no panel to install next to it.



NOTES:

- > Do not re-install the tiles right away, might need them off to install next frames.
- > Sponge to be inserted before last panel is installed.

hardware needed

panel height (inches)	37	45	53	61	69	77	85
2 way, 120 connector 	2X	3X	3X	3X	3X	3X	4X
25mm hex screw 	8X	12X	12X	12X	12X	12X	18X

tools needed

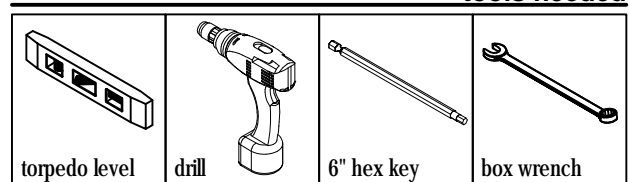

panel assembly - L-135° configuration

1. Line up two panels, (Figure 1).
2. Level off panels (use the torpedo level) by adjusting glides, (Figure 2).

FIGURE 1

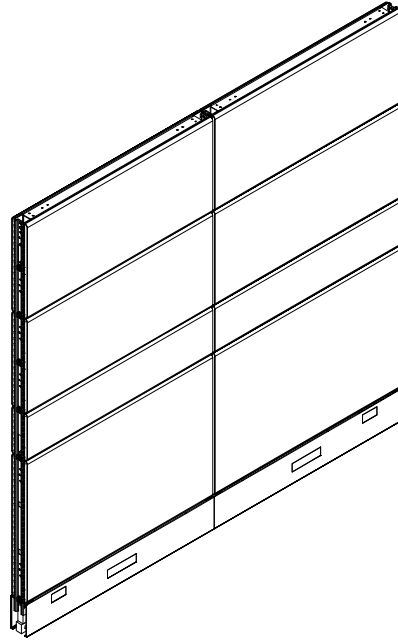
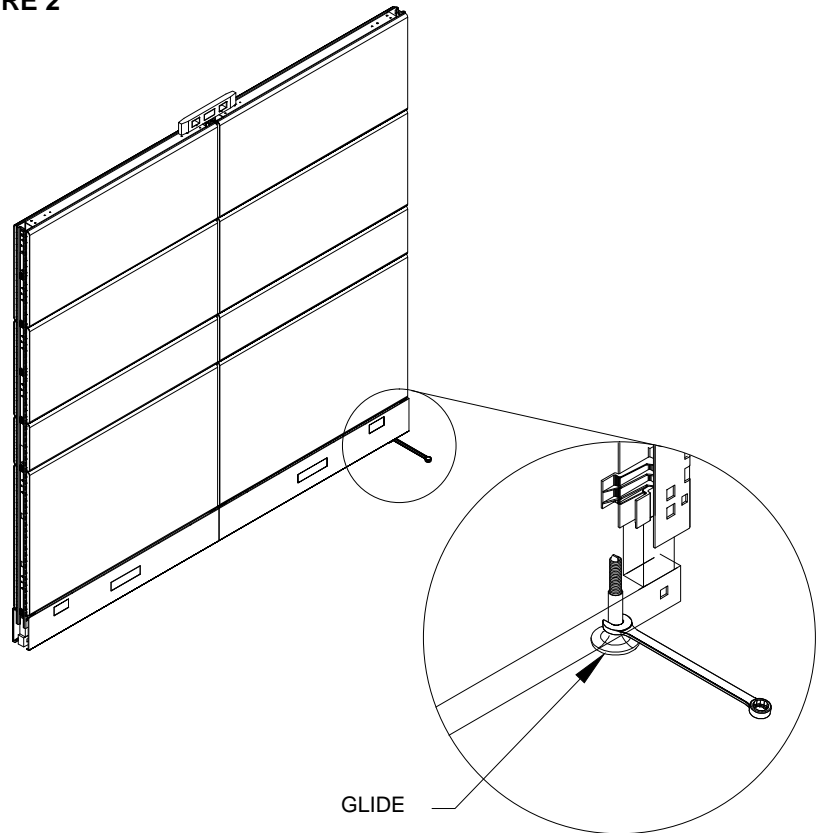
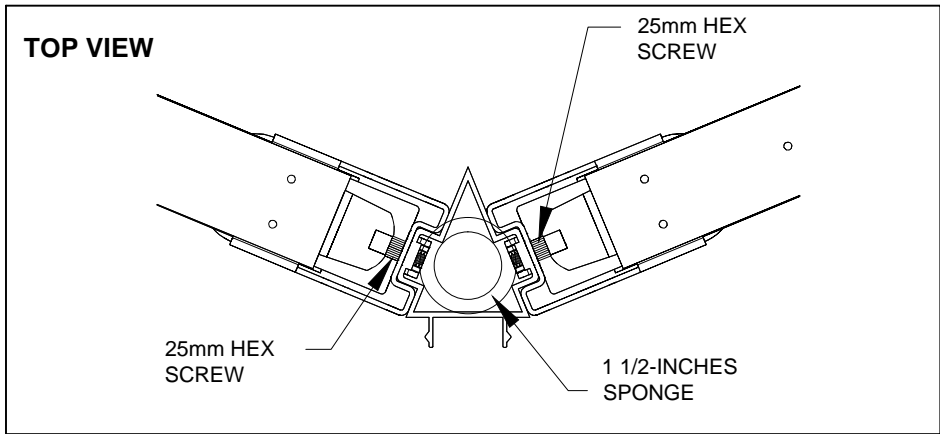
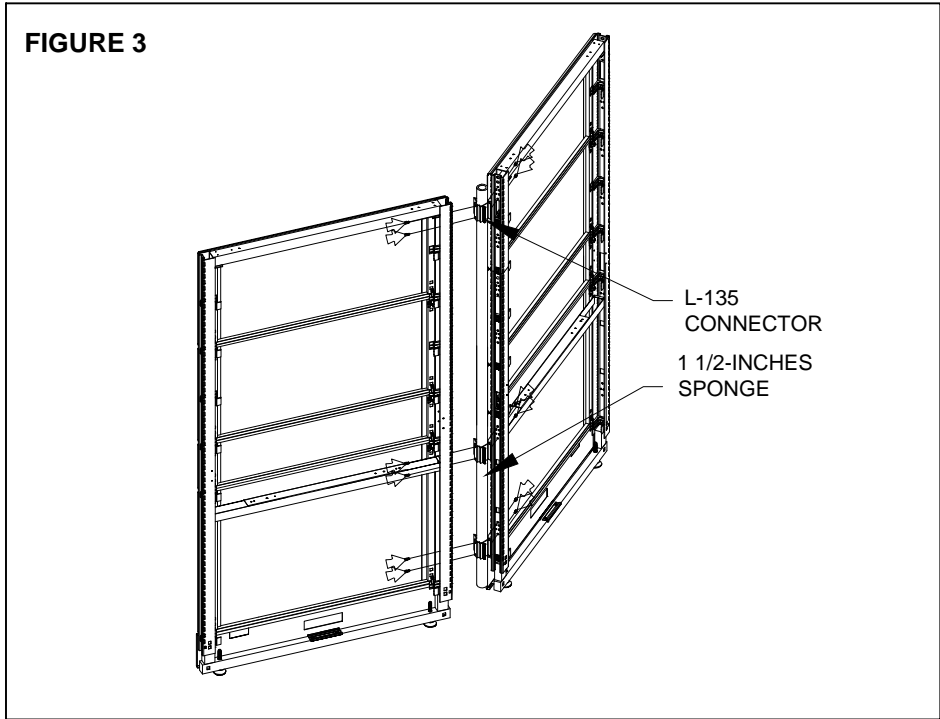

FIGURE 2



panel assembly - L-135° configuration (cont'd)



3. Remove all the tiles on one side of each panel.
4. Rotate one panel to create a 135-degree angle.
5. Using a 6-inches hex key, install the 25 mm or 1-inch hex screws into the inside edge of the panel frame; this will protrude into the L-135 CONNECTORS, (Figure 3).
6. Insert a piece of 1 1/2-INCHES diameter sponge vertically so that light will not protrude through, (Figure 3).
7. Re-install the tiles previously removed, if there is no panel to install next to it.



NOTES:

- > Do not re-install the tiles right away, might need them off to install next frames.
- > Sponge to be inserted before last panel is installed.

hardware needed

panel height (inches)	37	45	53	61	69	77	85
L-135 connector 	2X	3X	3X	3X	3X	3X	4X
25mm hex screw 	8X	12X	12X	12X	12X	12X	18X

tools needed

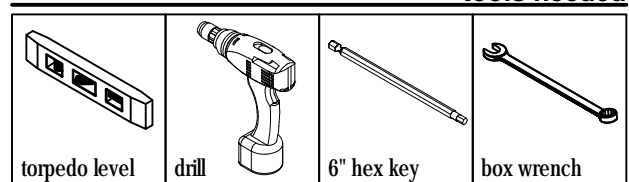

stackable frame connection

1. Remove the tiles on one side of the panel and the stackable panel. The stackable panel frame has two extrusions welded on its sides. Insert these extrusions into the top of the base frame of panel that has to be raised, (Figure 1).
2. Fasten the stackable frame panel extrusions by the base frame of the panel with a 25 mm or 1-inch hex screw on each side. The screws have to be inserted into the holes provided from the inside of the panel frame; use a 6-inches hex key to tighten, (Figure 2).

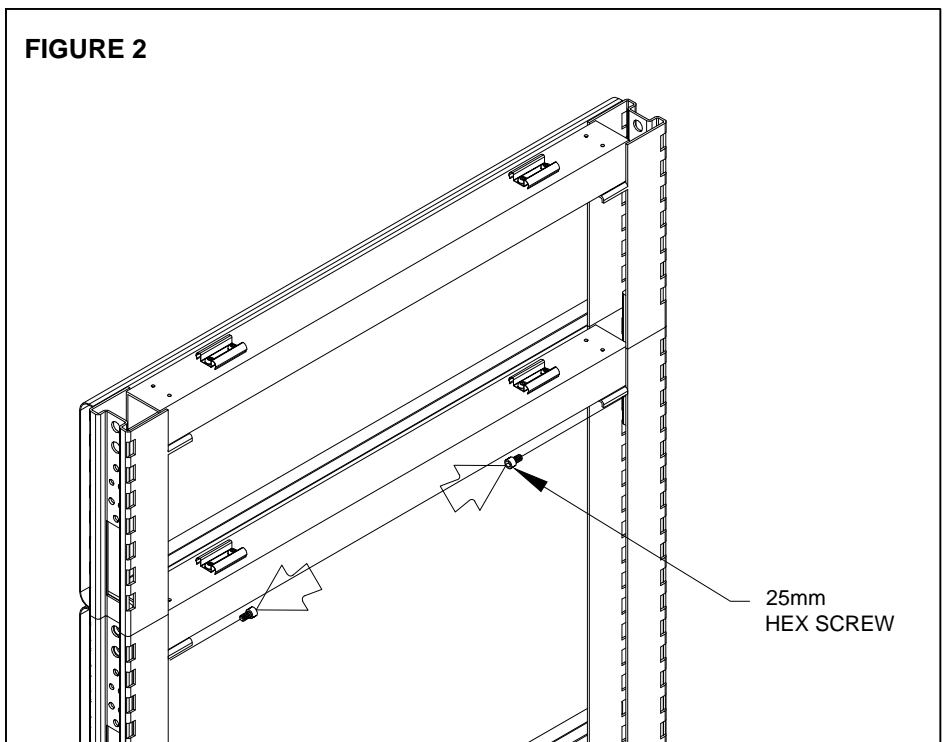
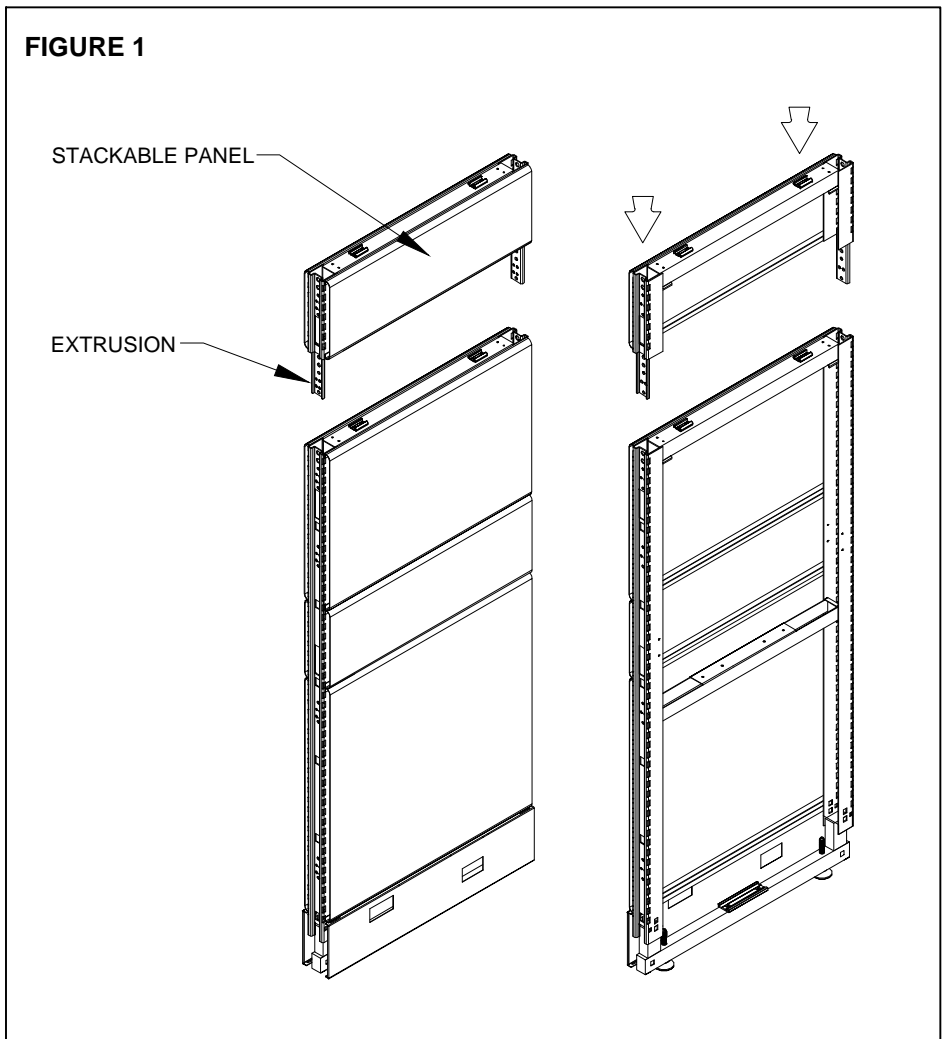

stackable frame connection (cont'd)

3. Screw two U brackets on top of the base panel frame, in the holes provided. The U brackets will hold the tiles that have to be inserted to the stackable frame, (Figure 3).
4. Complete the installation by inserting removed panel tiles and trims at their appropriate location.

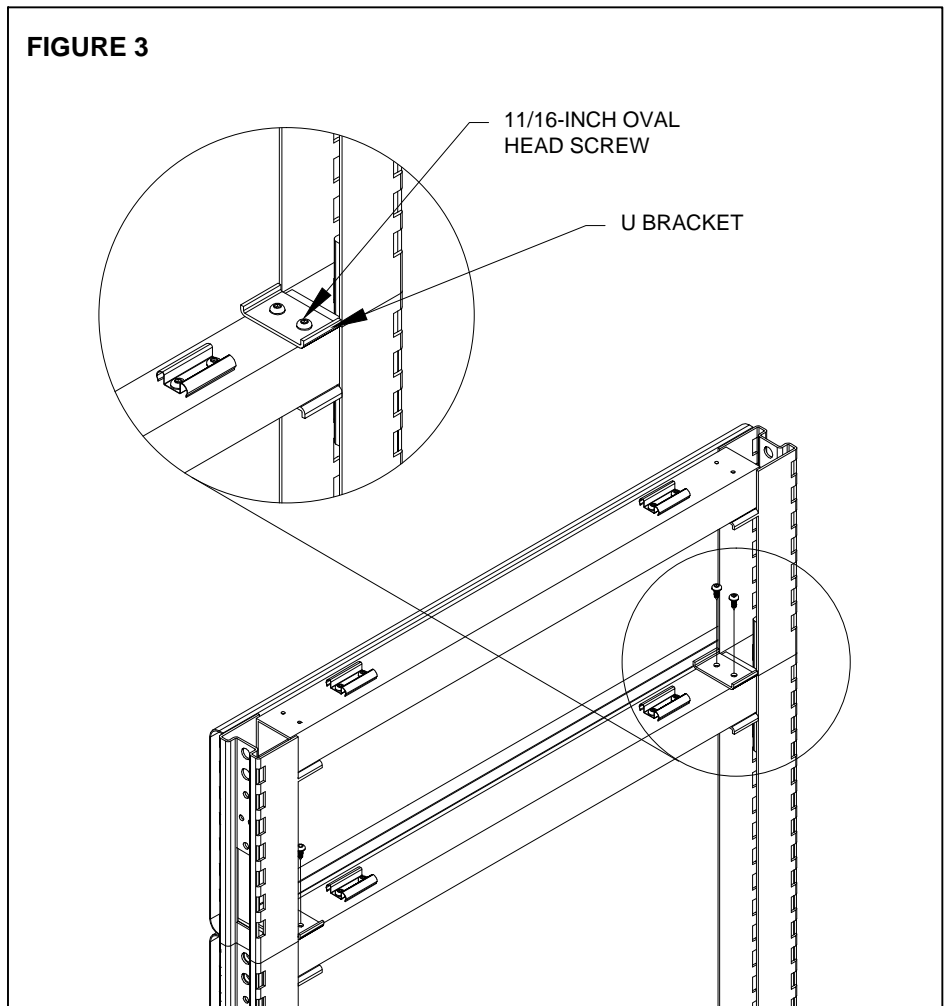

tools & hardware needed

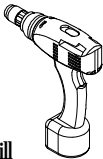
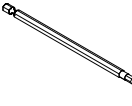
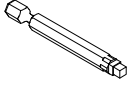
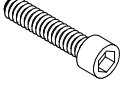
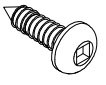
 drill	 6" hex key	 #1 Robertson bit	 4, 25mm hex screw	 4, 11/16" oval head screw
--	--	--	---	---

stackable frame connection to stackable frame

1. Fasten the stackable frame panels together with a 25 mm or 1-inch hex screw. The screws have to be inserted into the holes provided from the inside of the panel frame; use a 6-inches hex key to tighten.

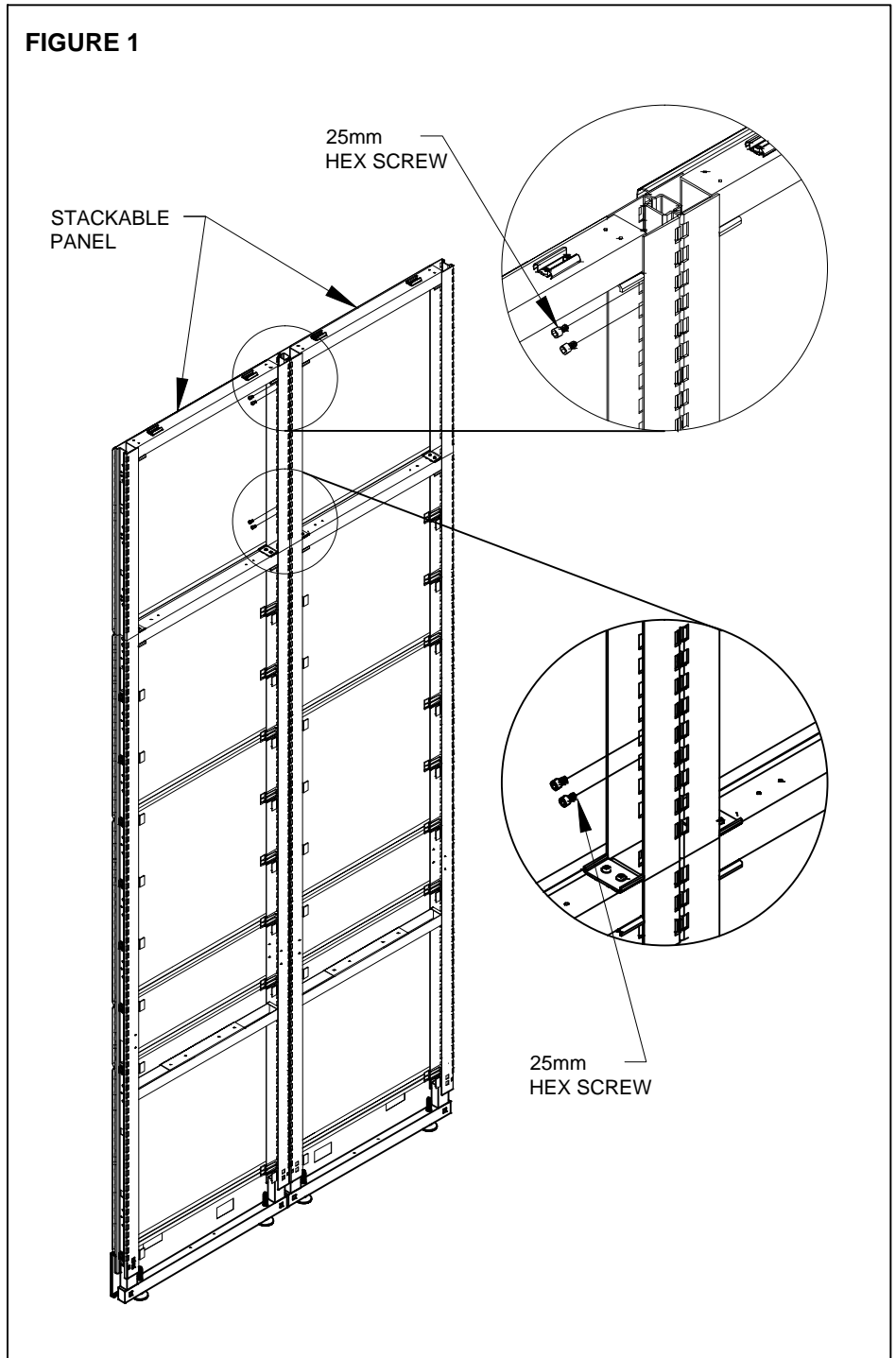

stackable frame connection to stackable frame (cont'd.)

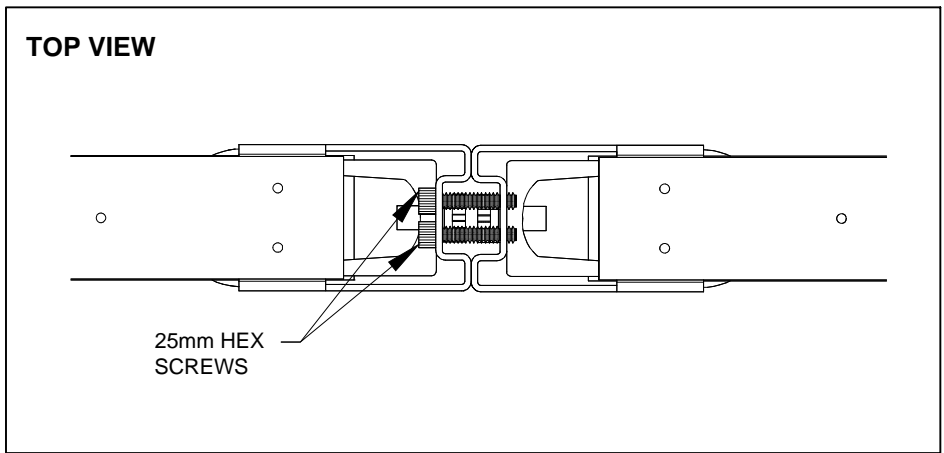

NOTE:



- > Do not re-install the tiles right away, might need them off to install next frames.

hardware needed

stackable panel height (inches)	8	16	24
25mm hex screw	4X	4X	4X

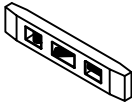
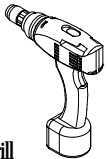
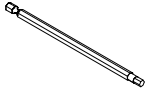

tools needed

 torpedo level	 drill	 6" hex key	 box wrench
---	--	---	---

stackable frame connection to door

1. Remove the tiles on one side of the panel and the stackable panel. Insert these extrusions into the top of the base frame of panel door, (Figure 1).
2. Fasten the stackable frame panel extrusions by the base frame of the panel with a 25 mm or 1-inch hex screw on each side. The screws have to be inserted into the holes provided from the inside of the panel frame; use a 6-inches hex key to tighten, (Figure 2).

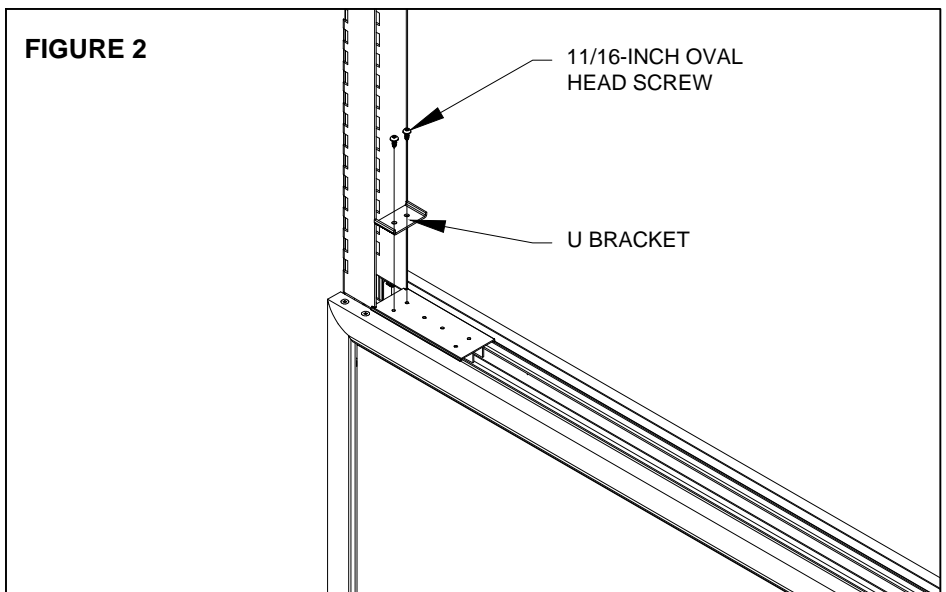
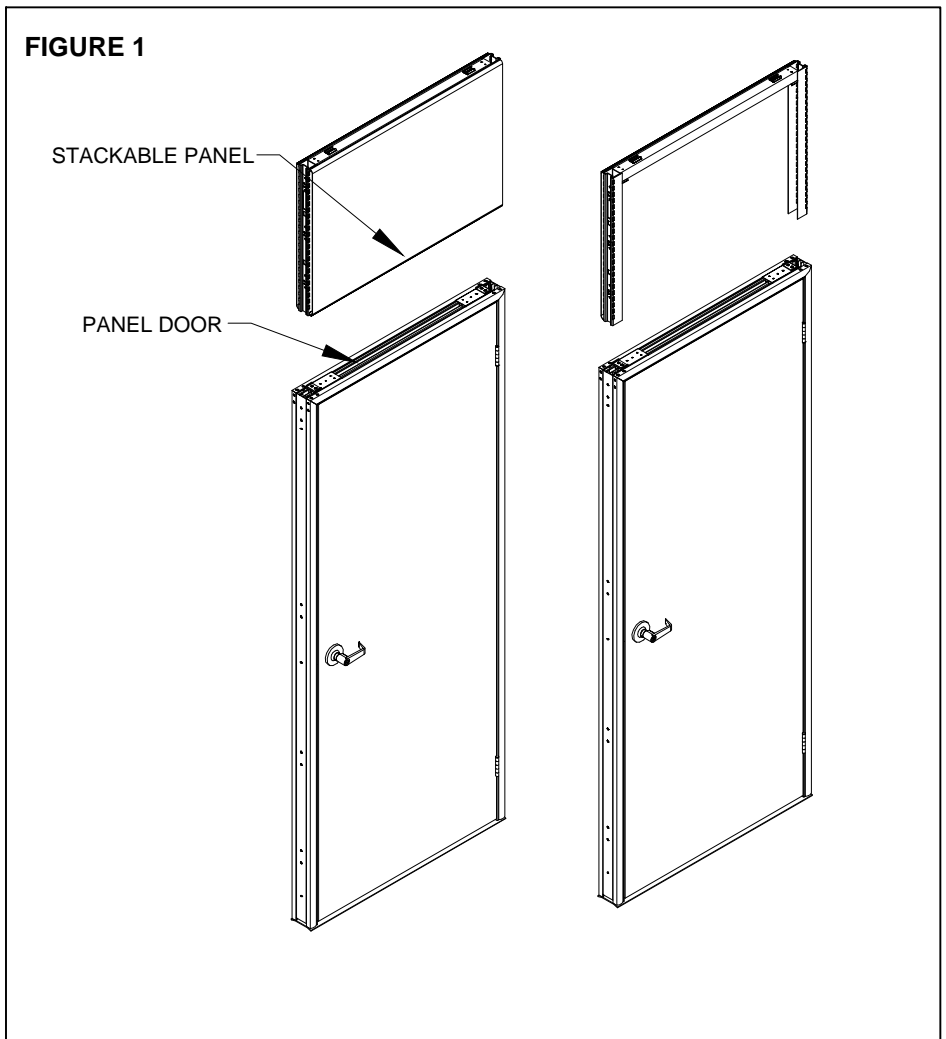

stackable frame connection to door with stackable panel frame

1. Fasten the stackable frame panels together with a 25 mm or 1-inch hex screw. The screws have to be inserted into the holes provided from the inside of the panel frame; use a 6-inches hex key to tighten.

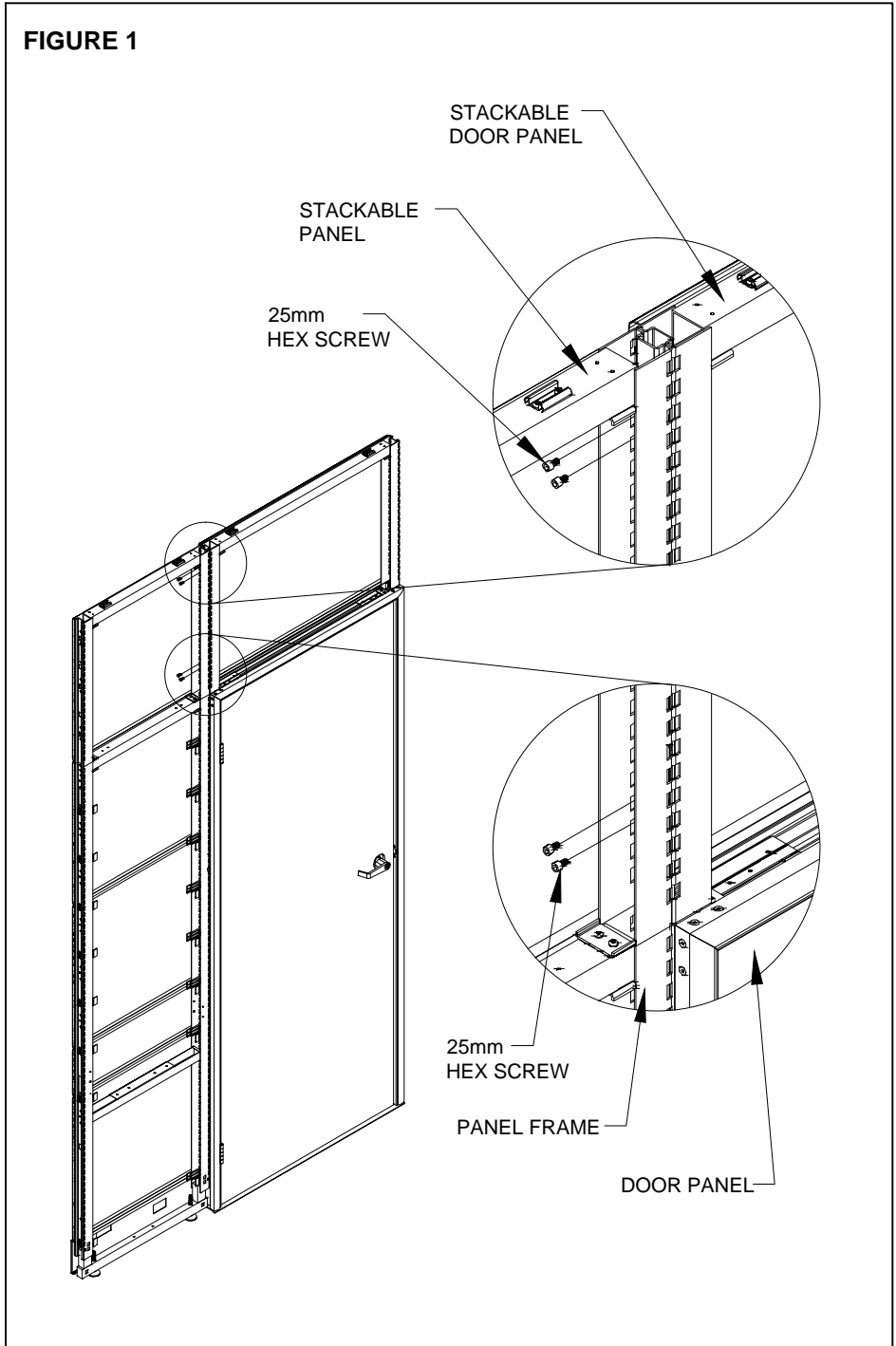

stackable frame connection to door with stackable panel frame (cont'd.)

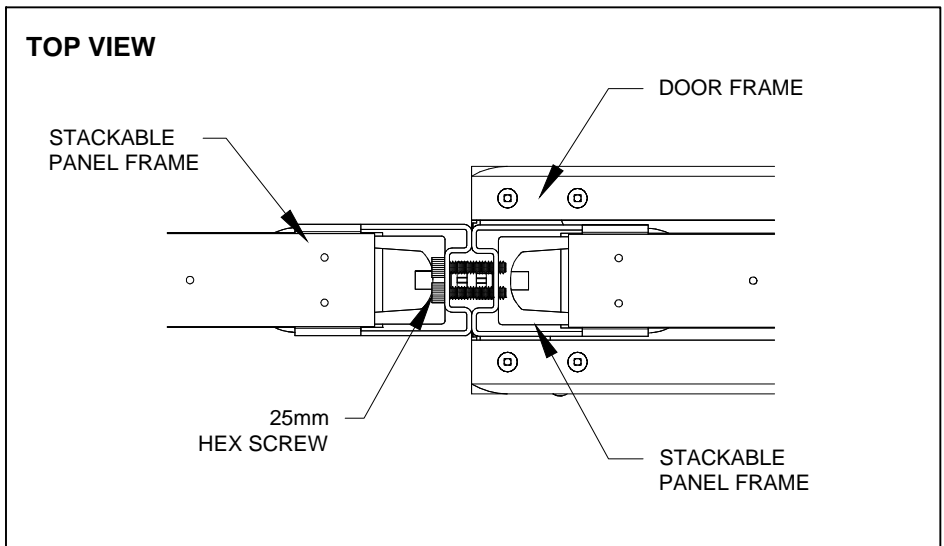





hardware needed

stackable panel height (inches)	8	16	24
25mm hex screw	4X	4X	4X

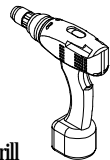

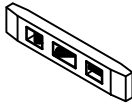
tools & hardware needed

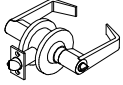
 drill	 box wrench	 torpedo level	 #2 Robertson long bit	 16, 1 1/2" self tapping screw	 1, lock set
--	---	---	--	--	--

door assembly - straight configuration

1. Make sure door is closed before starting installation, (Figure 1).
2. Remove all the tiles on one side of the panel.
3. Line up top of door frame with the existing panels, either to the left or to the right.
4. Using a #2 Robertson long bit, insert the 1 1/2-inches tapping screws into the holes on the edge of the panel frame, which will then protrude into the door frame, (Figure 2).
5. Step on the metal threshold bar to level off with the floor.

FIGURE 1

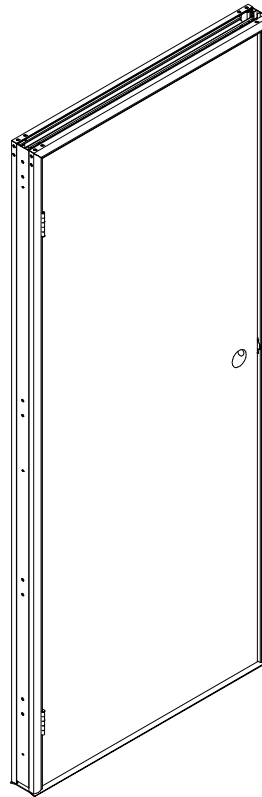
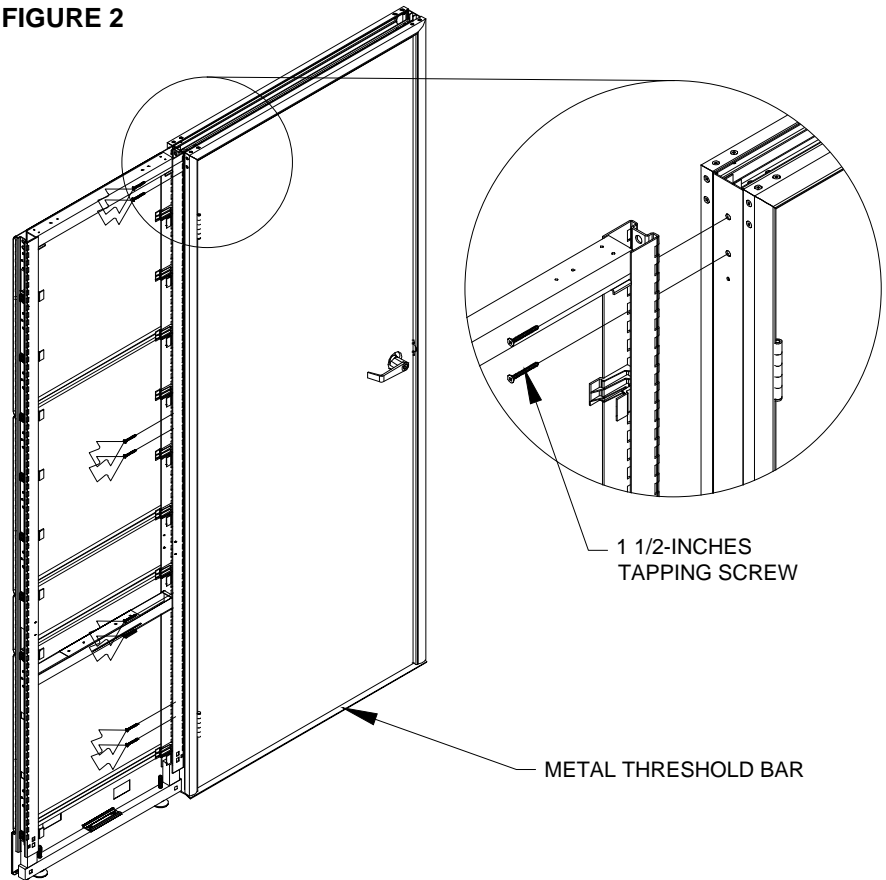
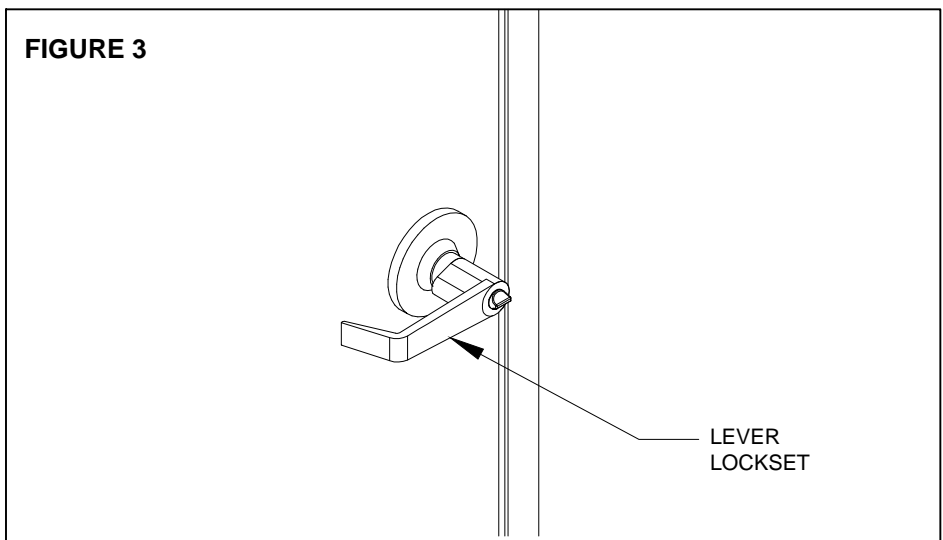
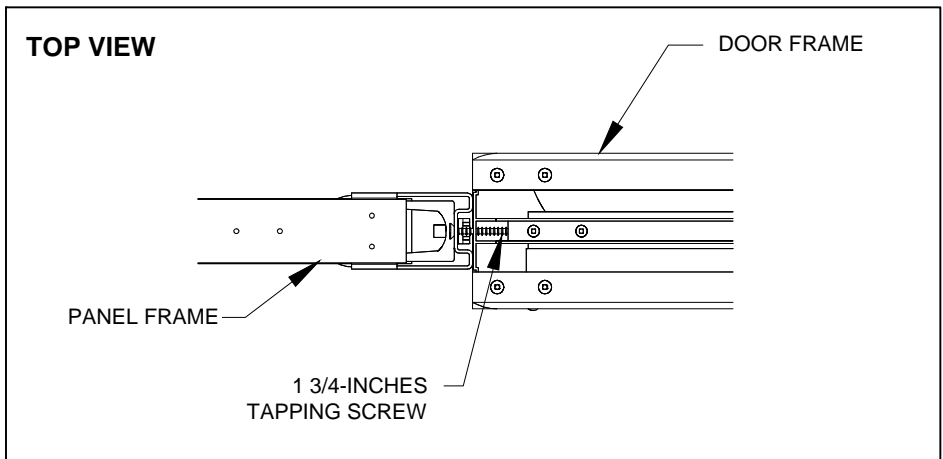

FIGURE 2







door assembly - straight configuration (cont'd)

6. Install lever lock set (installation instructions are included with the lock set), Figure 3.
7. Re-install the tile previously removed.

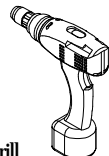

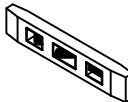
tools & hardware needed

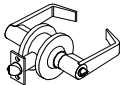
 drill	 box wrench	 torpedo level	 #2 Robertson long bit	 16, 1 1/2" self tapping screw	 1, lock set
--	---	---	--	--	--

door assembly - 90°, "T", Cross, 120°, 135° and straight configuration

1. Make sure door is closed before starting installation, attach the corresponding filler connectors to the side of the door, with 25 mm or 1-inch hex screws, (Figure 1).
2. Remove all the tiles on one side of the panel and line up to the top of the door frame with the existing panels, either to the left or to the right.
3. Using a 6-inches hex key, insert the 25 mm or 1-inch hex screws into the holes on the edge of the frame, from the inside; the screws will protrude into the connectors, (Figure 2). Follow the instructions of the frame assembly for the other configurations.
4. Step on the metal threshold bar to level off with the floor.

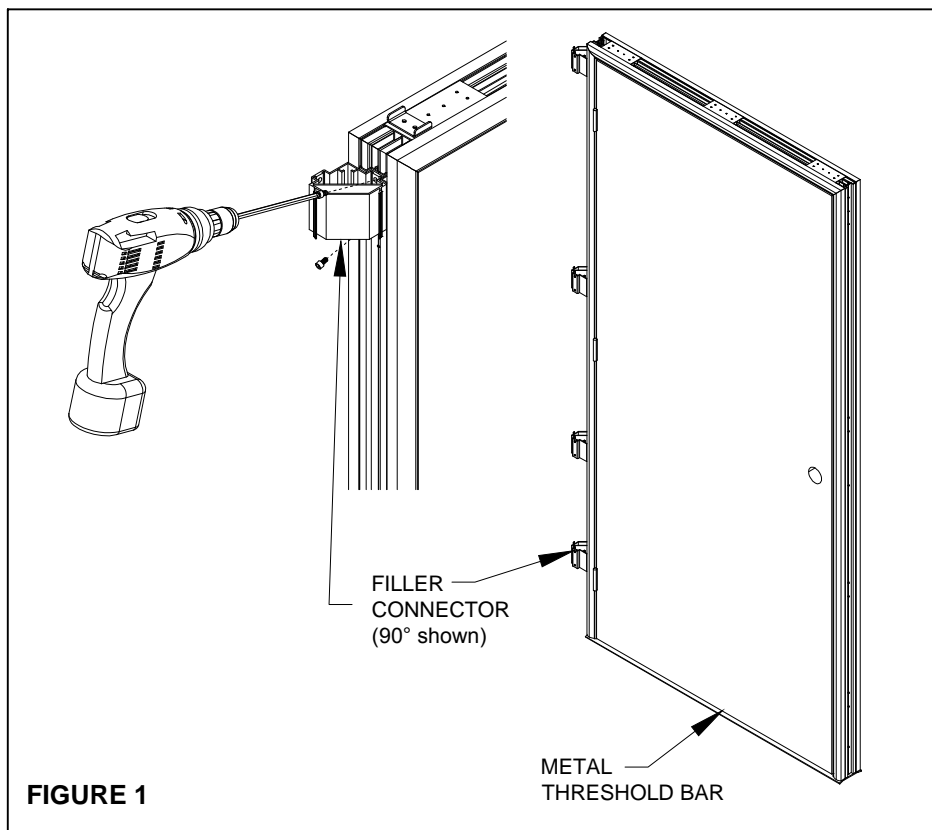

FIGURE 1

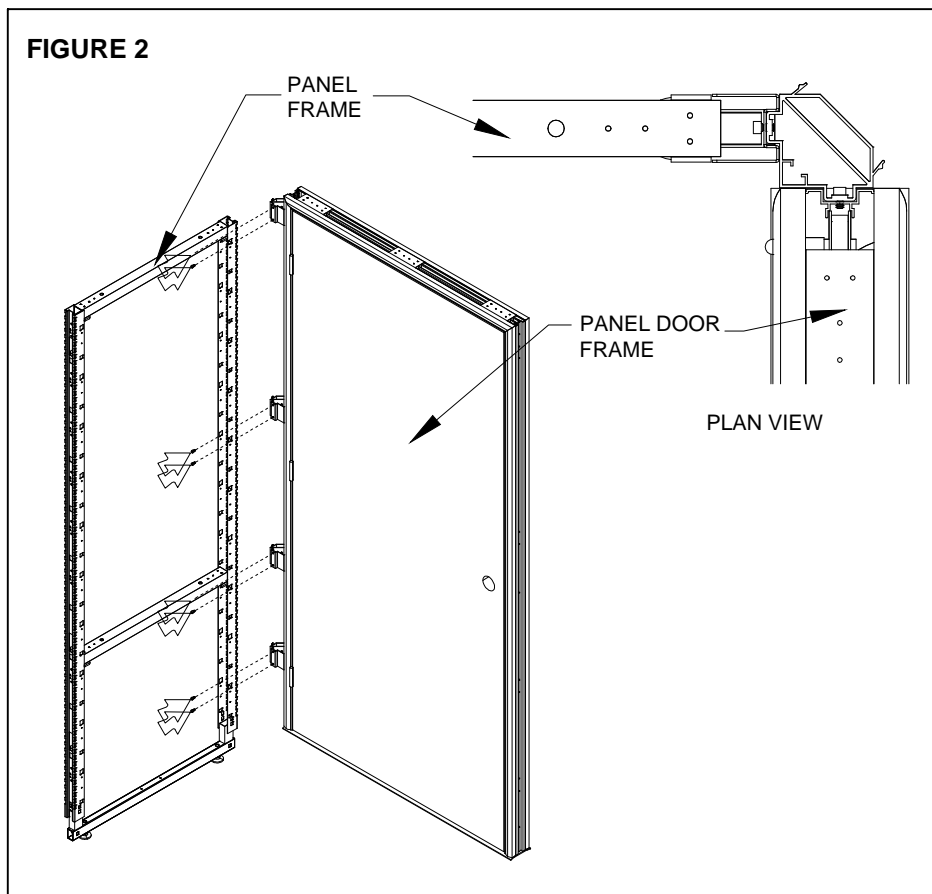
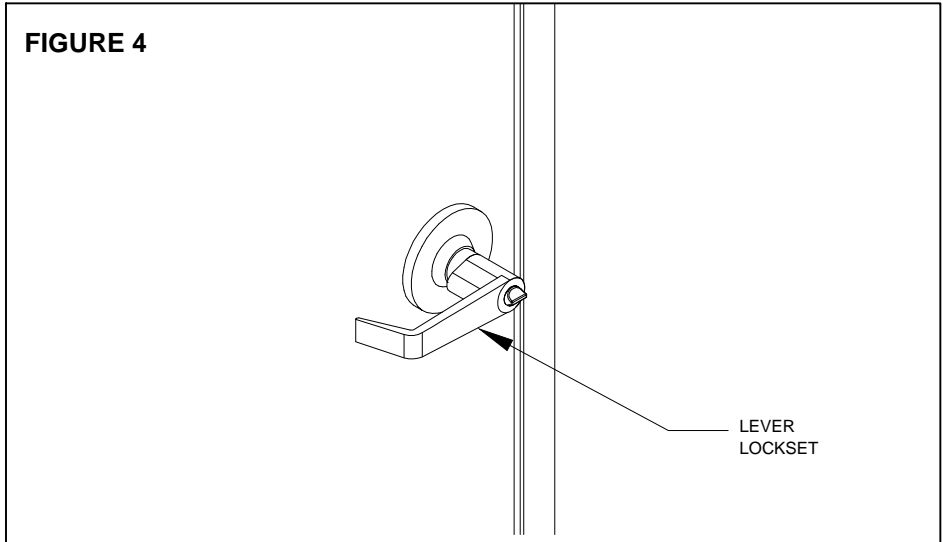









FIGURE 2

door assembly - 90°, "T", Cross, 120°, 135° and straight configuration (cont'd)





5. Install lever lock set (installation instructions are included with the lock set), (Figure 4).
6. Re-install all the tiles previously removed.



connectors

 4X	 4X	 4X	 4X
 4X	 4X	 4X	

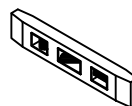
tools & hardware needed

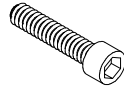
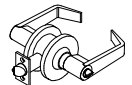
 drill	 box wrench	 torpedo level	 6" hex key	 8, 25mm hex screw	 1, lock set
--	---	---	---	---	--

door with stackable frame to wall - adjustable connection

1. Make sure door is closed before starting installation. Attach the stacking frame to the top of the panel door; refer to the installation guide: stackable frame connection to door.
2. Measure height of frame to be mounted from floor to top of frame. Mark this height on the wall.
3. Place the adjustable connector (Type 1, 2 or 3) against the wall using the mark as a guide. Check for plumbness.
4. Using a torpedo level, level the adjustable connector with the side of the frame.
5. Mark wall with a pencil through the pre-drilled holes in the adjustable wall connector.

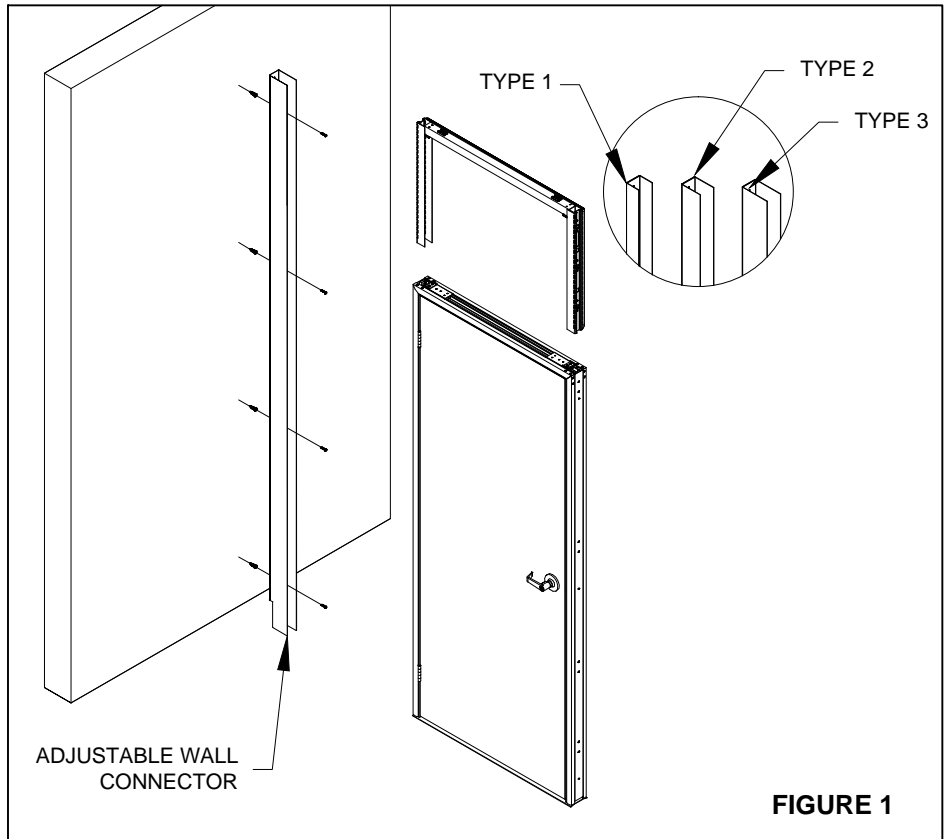

6. Remove wall connector, then drill wall through the markings. Insert wall anchors.
7. Place the adjustable wall connector back onto the wall, line up the holes on both wall and connector, then place the #10 screws provided through holes and tighten, using #2 Robertson long bit, (Figure 1).
8. Using the #2 Robertson long bit, attach the 2 x 2-inches square tubing onto the edge of the frame, with #10 self tapping screws, from the inside of the frame, (Figure 2).

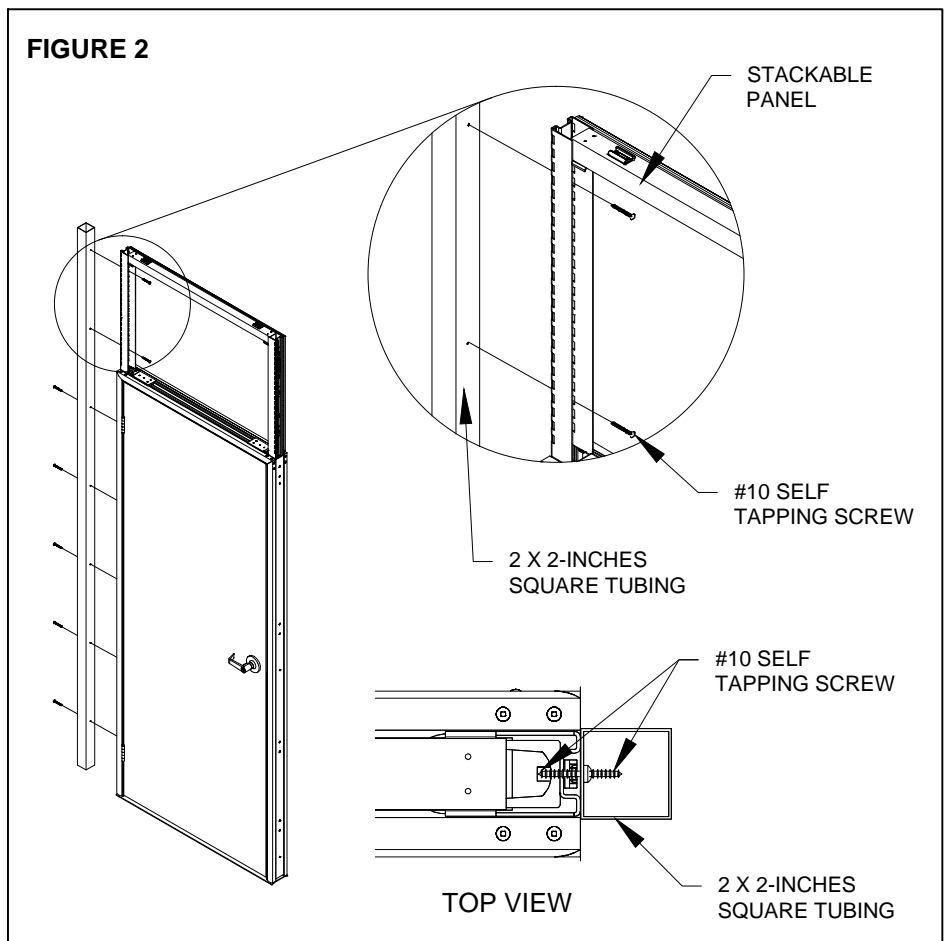

door with stackable frame to wall - adjustable connection (cont'd)

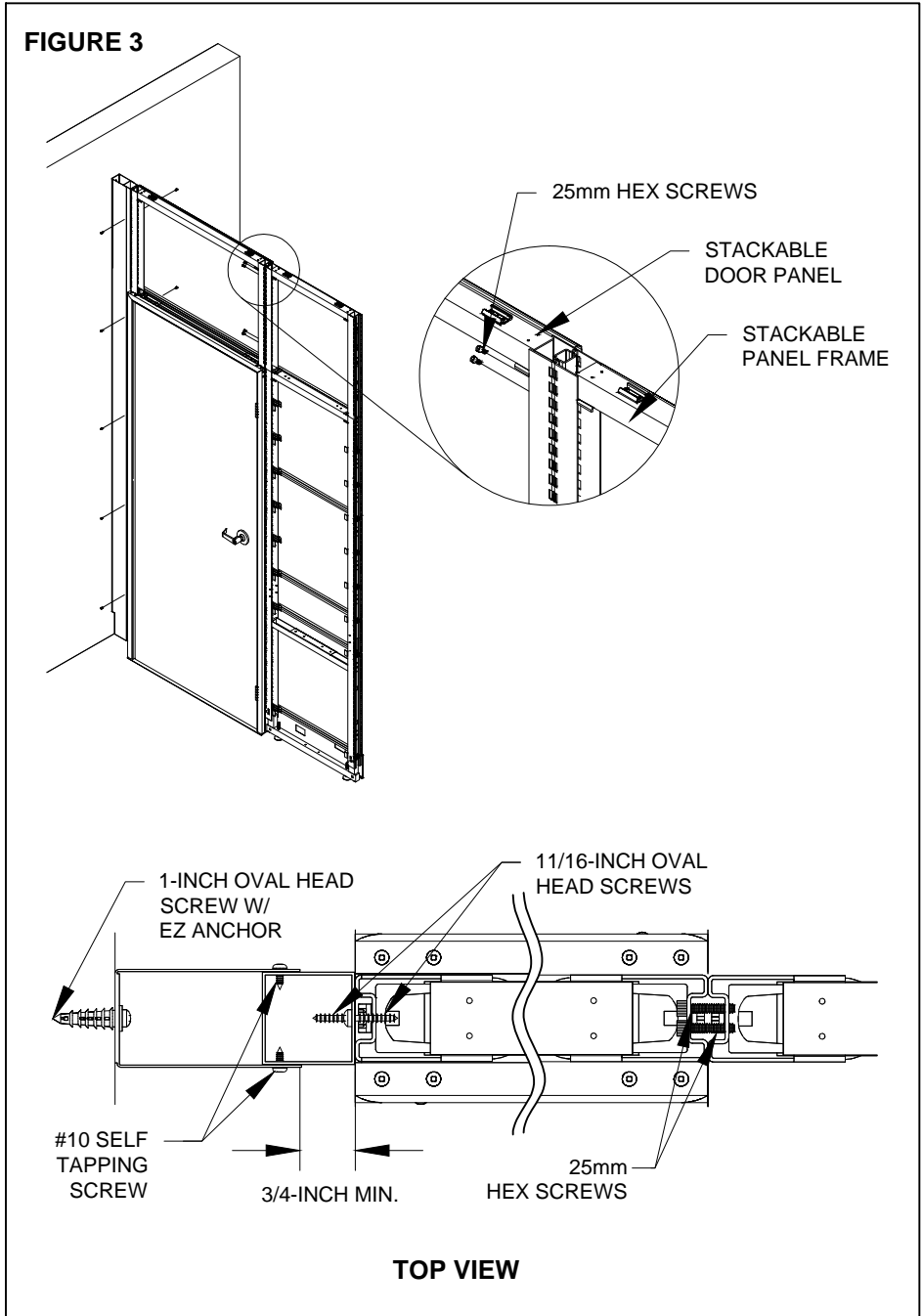

9. Insert the frame-square tubing configuration into the adjustable wall connector according to the gap between frame and wall. Tighten frame-square tubing with wall connector on both sides using 11/16-inch oval head screws, with #2 Robertson bit, (Figure 3).
10. Attach the door with stackable frame to panel frame; refer to the installation guide: stackable frame connection to door with stackable panel frame.
11. Install the tiles; refer to the intallation guide: panel tile installation.
12. Attach the top trim refer to the section "top trim installation, panel to wall - adjustable connection".
13. Step on the metal threshold bar to level off with the floor.



NOTES:

- > Illustrations show anchorage to dry wall. Only E-Z anchors are suitable for dry wall installation which are provided by Tayco.
- > Tayco is not responsible for providing the appropriate hardware for different types of wall construction for non-Tayco installations.

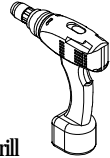
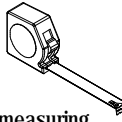
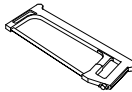
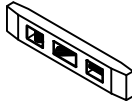
tools & hardware needed

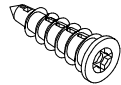
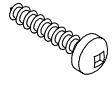
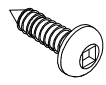
 drill	 measuring tape	 hacksaw	 torpedo level	 #2 Robertson bit	 #3 drill bit
 EZ anchor	 1" oval head screw	 11/16" oval head screw			

sliding door installation

1. Remove the top bracket from the sliding door vertical post and insert the vertical post cap into the vertical post, (Figure 1).
2. Remove the top trim and the plastic connector on one side of the top trim on the frame where the sliding door is going to be installed, (Figure 2).
3. Position the vertical post at the edge of the frame and screw it to the frame with six 1-inch self tapping screws, (Figure 3); Figure 4 shows which holes in the frame are to be used.

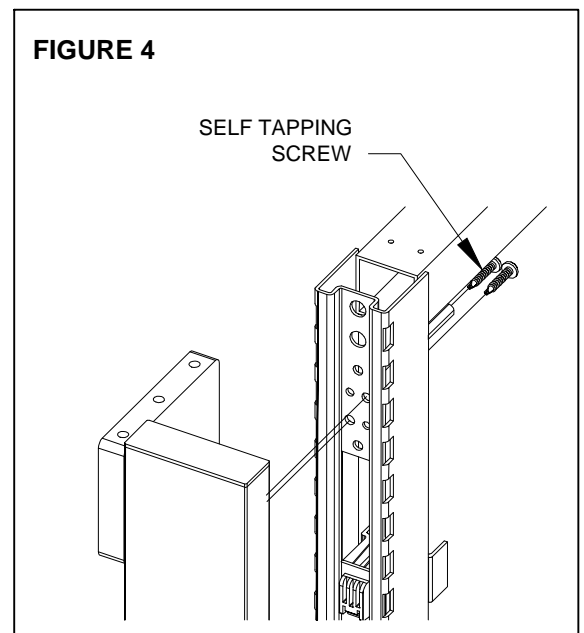
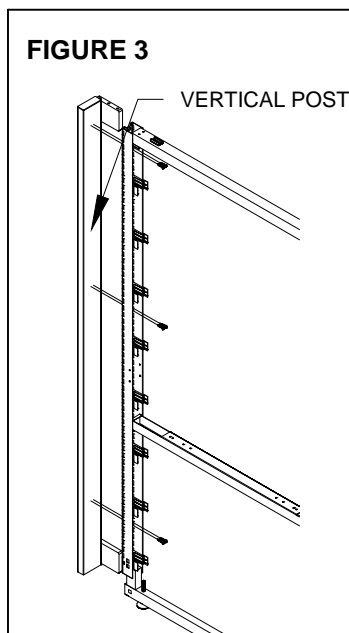
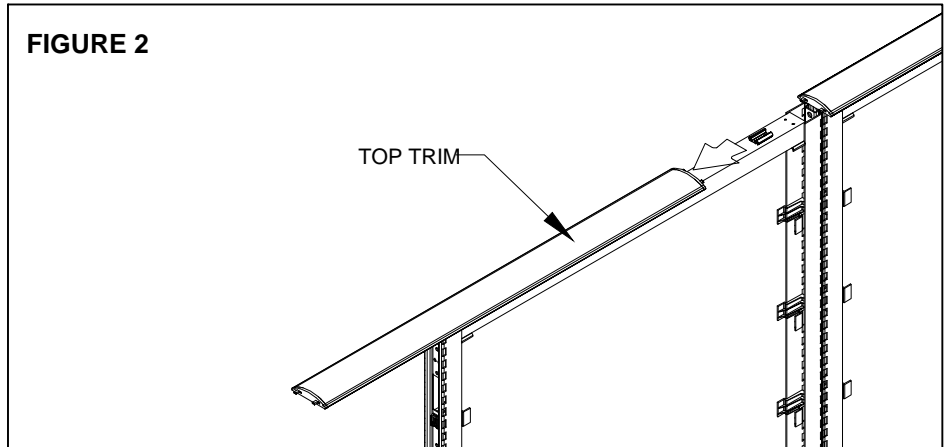
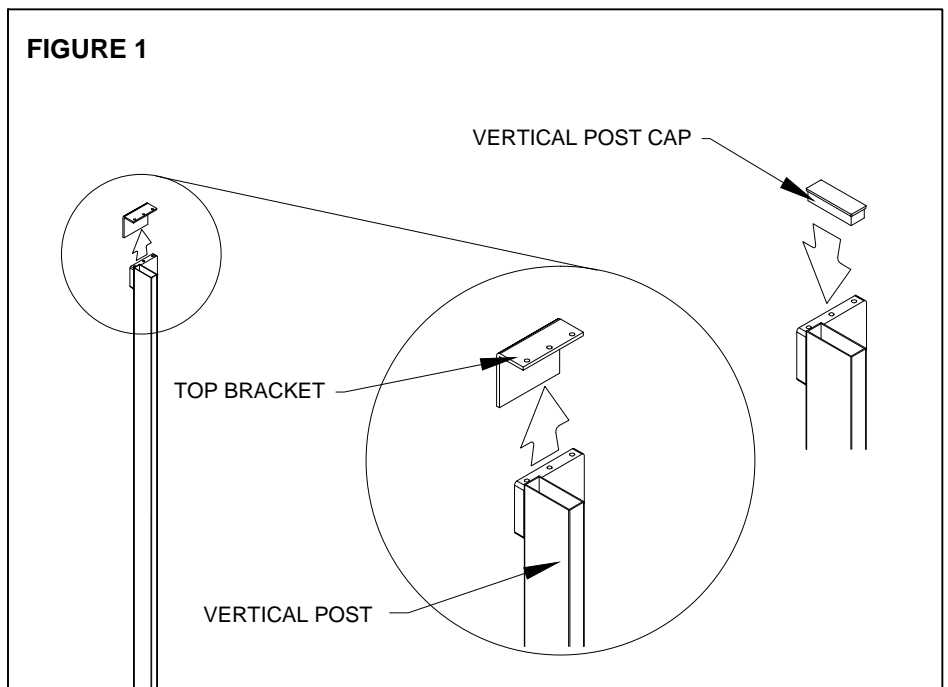

sliding door installation (cont'd)

4. Insert plastic connectors to both ends of the trim and install the assembled trim on top of the frame, (Figure 5).
5. Install all tiles on the frame where the sliding door is being installed, (Figure 6).
6. Place the sliding door into the bottom bracket of the vertical post, (Figure 7).

FIGURE 5

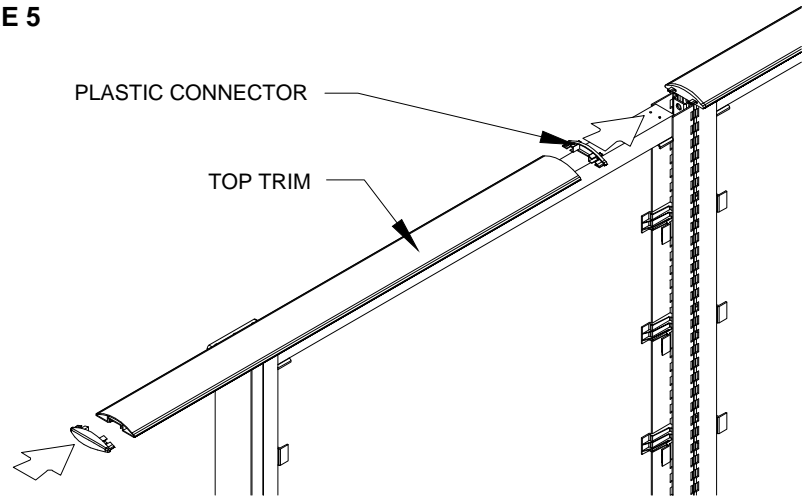

FIGURE 6

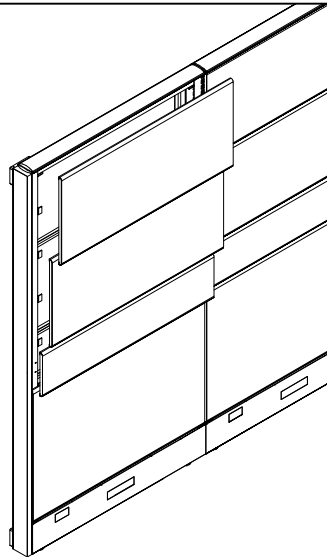
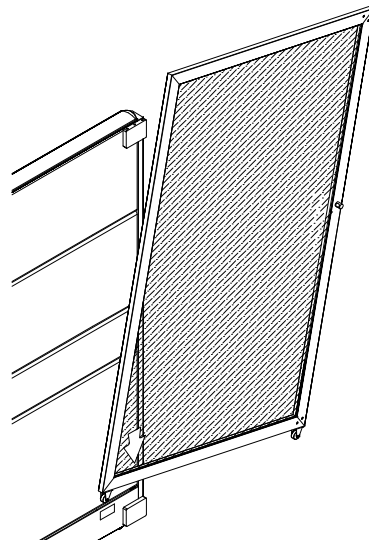
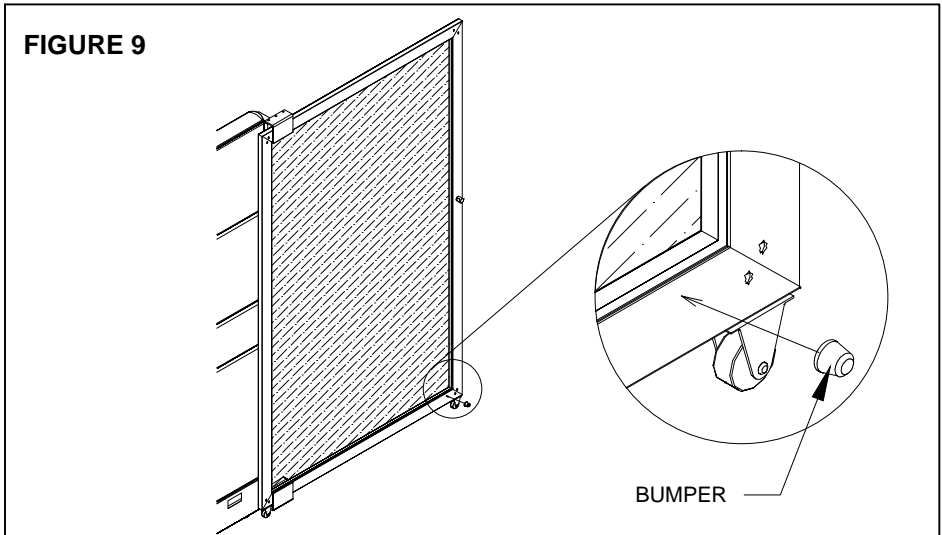
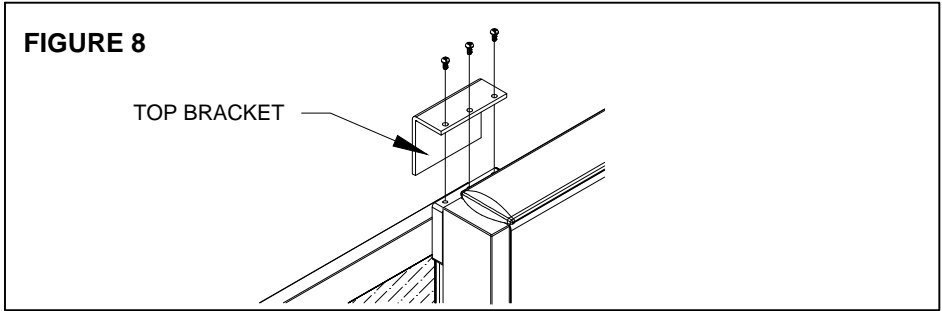

FIGURE 7







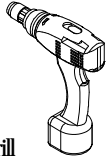

sliding door installation (cont'd)

7. Screw the top bracket back on to the vertical post, (Figure 8).
8. Stick the bumper to the bottom corner of sliding door, (Figure 9). The bumper and screws are on the same side of the frame door. Door side with bumper and screws to be installed inside the office.

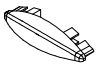

tools & hardware needed

 drill	 #2 Robertson bit	 6, 1" self tap robertson screw	 3, 1/2" #20 1/4" machine screw
	 1, vertical post cap	 1, top trim plastic connector	 1, bumper

panel to wall - adjustable connection

1. Remove all the tiles on one side of the panel.
2. Measure height of frame to be mounted from floor to top of frame. Mark this height on the wall.
3. Place the adjustable connector (Type 1, 2 or 3) against the wall using the mark as a guide. Check for plumbness.
4. Using a torpedo level, level the adjustable connector with the side of the frame.
5. Mark wall with a pencil through the pre-drilled holes in the adjustable wall connector.
6. Remove wall connector, then drill wall through the markings. Insert wall anchors.
7. Place the adjustable wall connector back onto the wall, line up the holes on both wall and connector, then place the #10 screws provided through holes and tighten, using #2 Robertson long bit, (Figure 1).
8. Using the #2 Robertson long bit, attach the 2 x 2-inches square tubing onto the edge of the frame, with #10 self tapping screws, from the inside of the frame, (Figure 2).

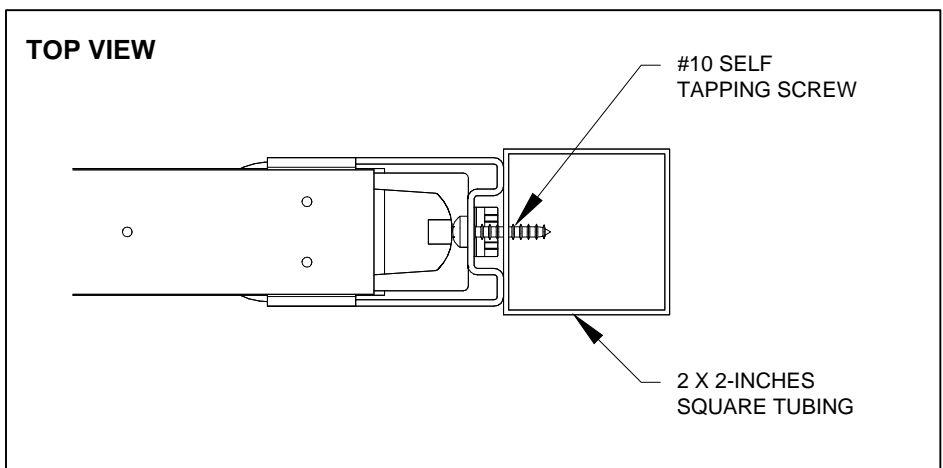
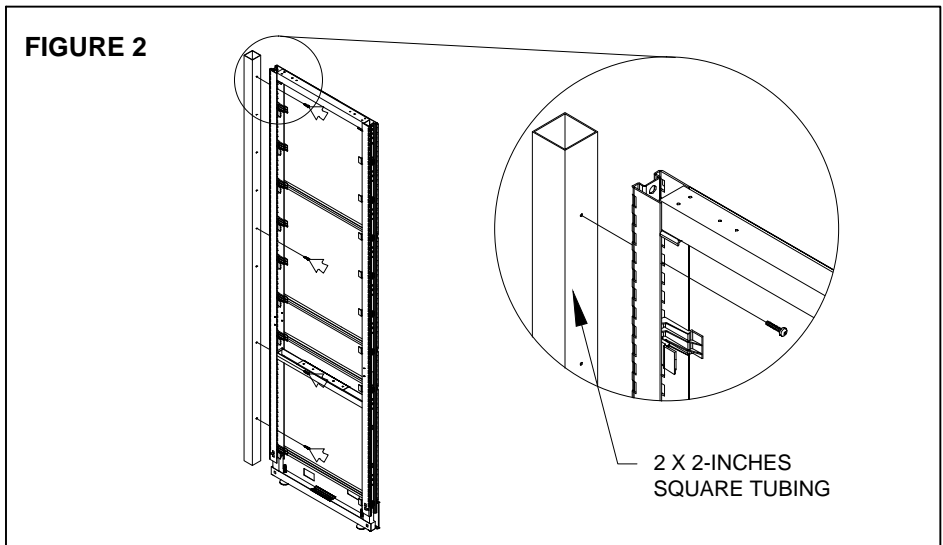
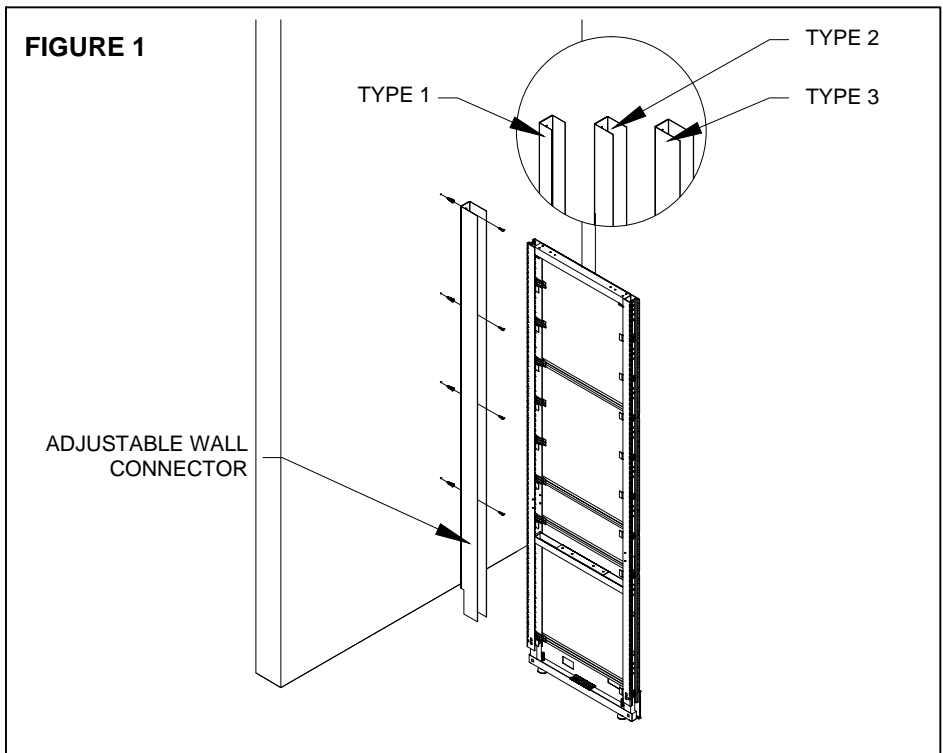

panel to wall - adjustable connection (cont'd)

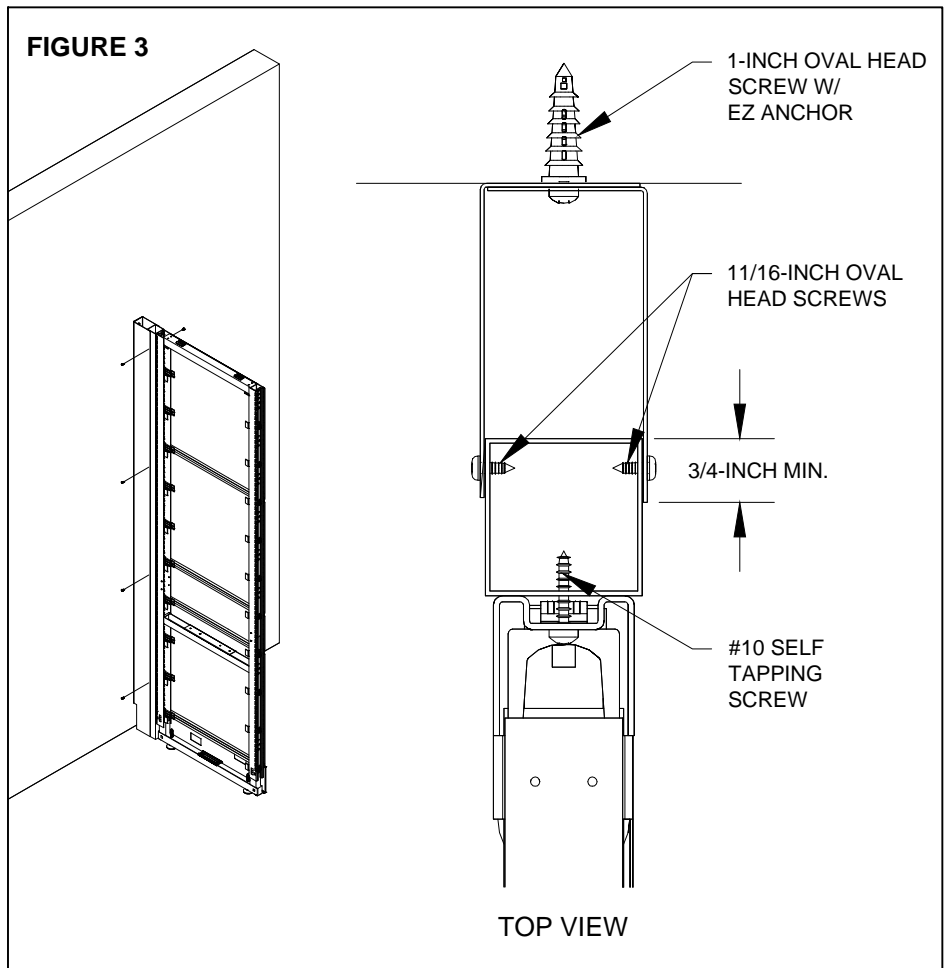

9. Insert the frame-square tubing configuration into the adjustable wall connector according to the gap between frame and wall. Tighten frame-square tubing with wall connector on both sides using 11/16-inch oval head screws, with #2 Robertson bit, (Figure 3).
10. Attach the top trim refer to the section "top trim installation, panel to wall - adjustable connection".
11. Re-install the tiles previously removed



NOTES:

- > Illustrations show anchorage to dry wall. Only E-Z anchors are suitable for dry wall installation which are provided by Tayco.
- > Tayco is not responsible for providing the appropriate hardware for different types of wall construction for non-Tayco installations.

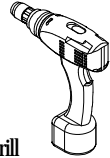
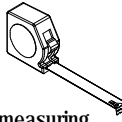
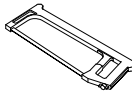
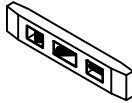
tools & hardware needed

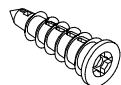
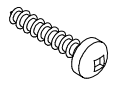
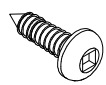
 drill	 measuring tape	 hacksaw	 torpedo level	 #2 Robertson bit	 #3 drill bit
			 EZ anchor	 1" oval head screw	 11/16" oval head screw

top trim installation panel to wall - adjustable connection

1. Measure the length of the panel with the wall connector (X), cut the 66-inches top trim to size the using the hacksaw, (Figure 1).
2. Attach the top trim, (Figure 2). Follow the installation sequence for top trims, refer to the section "panel trim and filler installation".

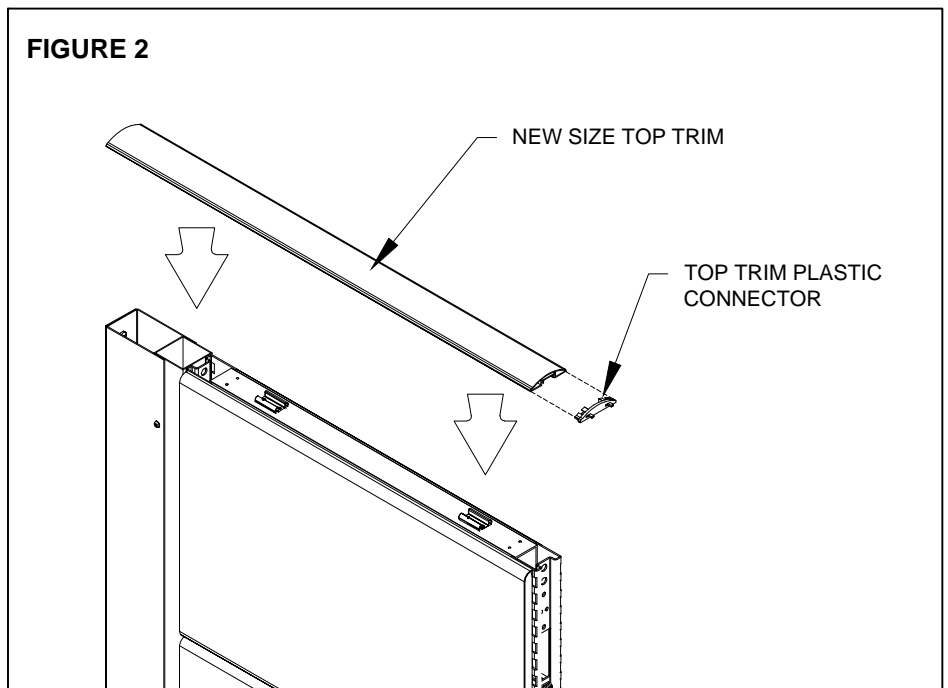
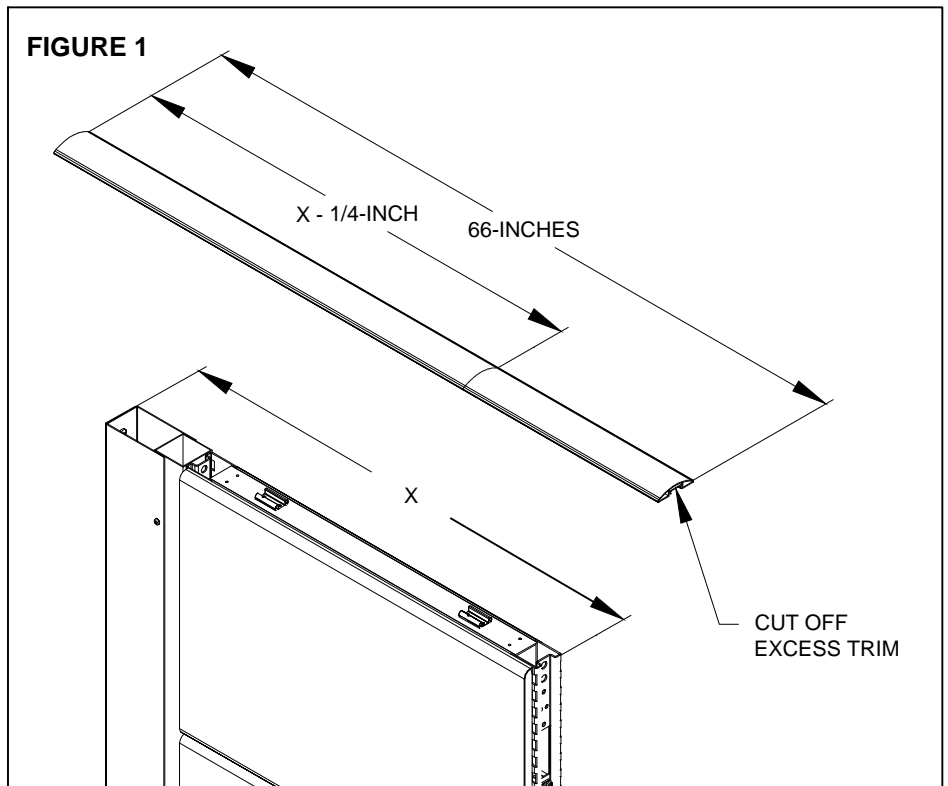

NOTE:

- > For wood top trims use X as the cutting length and follow the installation sequence for wooden top trims, refer to the section "panel wood trim installation".

tools & hardware needed

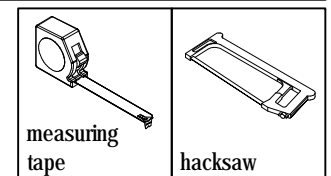

panel to wall - direct connection

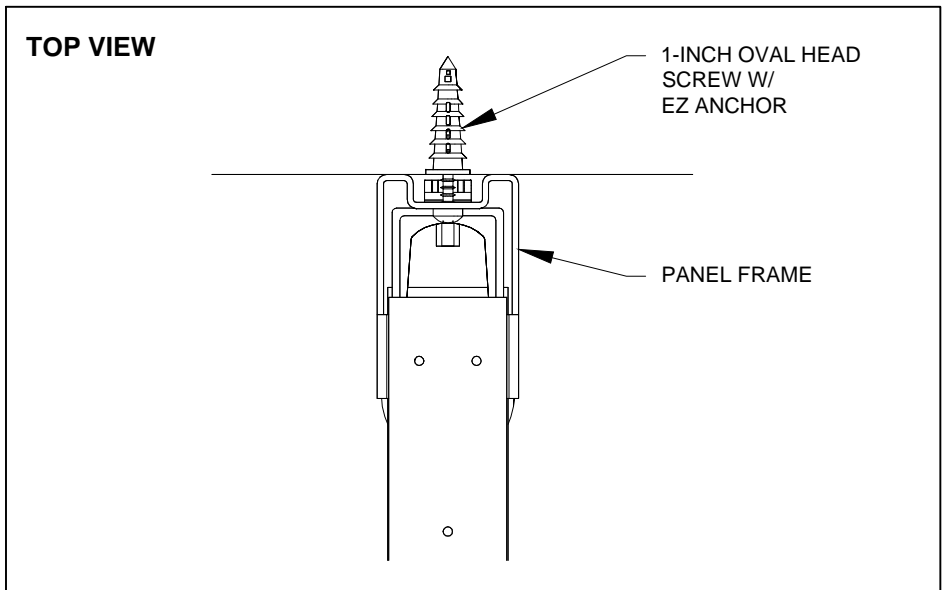
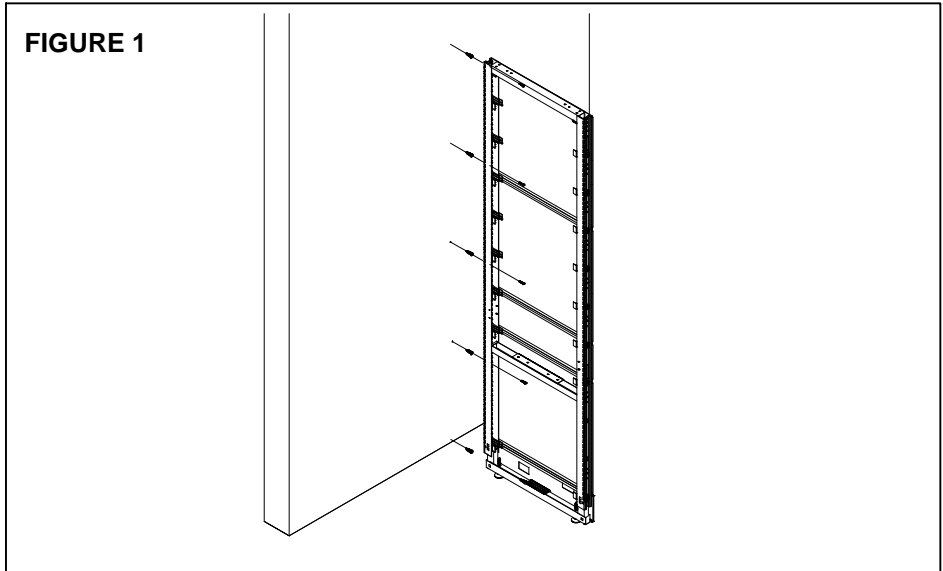

1. Remove all the tiles on one side of panel. Place the panel against the wall, then mark the wall through the pre-drilled holes in the frame, with a pencil. Place torpedo level on side of panel for levelness. Check for plumbness.
2. Remove panel frame, then drill wall through the markings. Insert wall anchors.
3. Swing panel back to the wall and line it up with wall anchors, then place the 1-inch oval head screws provided through holes and tighten using #2 Robertson bit.
4. Re-install the tiles previously removed.



NOTES:

- > Illustrations show anchorage to dry wall. Only E-Z anchors are suitable for dry wall installation which are provided by Tayco.
- > Tayco is not responsible for providing the appropriate hardware for different types of wall construction for non-Tayco installations.

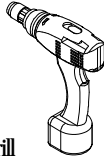
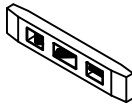
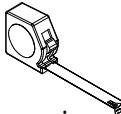
tools & hardware needed

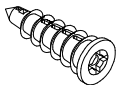
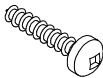
 drill	 torpedo level	 measuring tape	 #2 Robertson bit
 #3 drill bit	 EZ anchor	 1" oval head screw	

panel kickplate installation

1. Remove tiles on one side of panel. Base clips must be pre-installed prior to installing the kick plate.
2. Install the chrome clips at the very last slot at the bottom of frame, by pushing the clip down and up into the slot, (Figure 1). The clip can be removed by pushing the upper cut out on the clip from the back of the frame.
3. Take the kick plate and angle it at a 45-degree angle. Insert the bottom clip into the slotted holes at the bottom of the kick plate. Then raise the kick plate up and push it into the frame until it clicks into the black clip, (Figure 2).

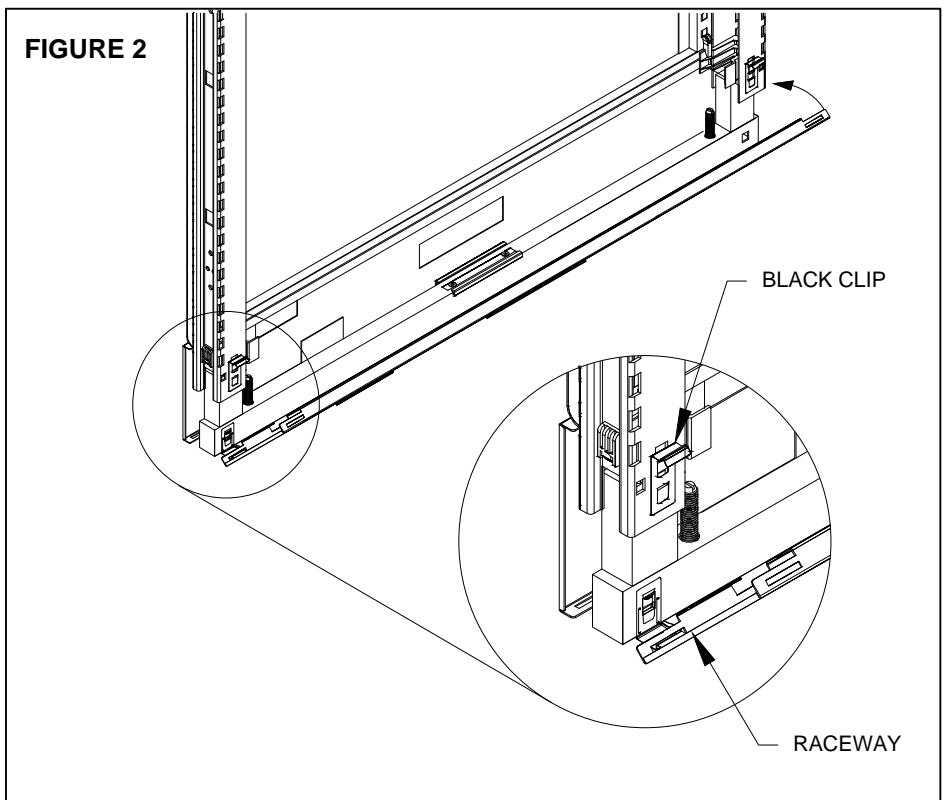
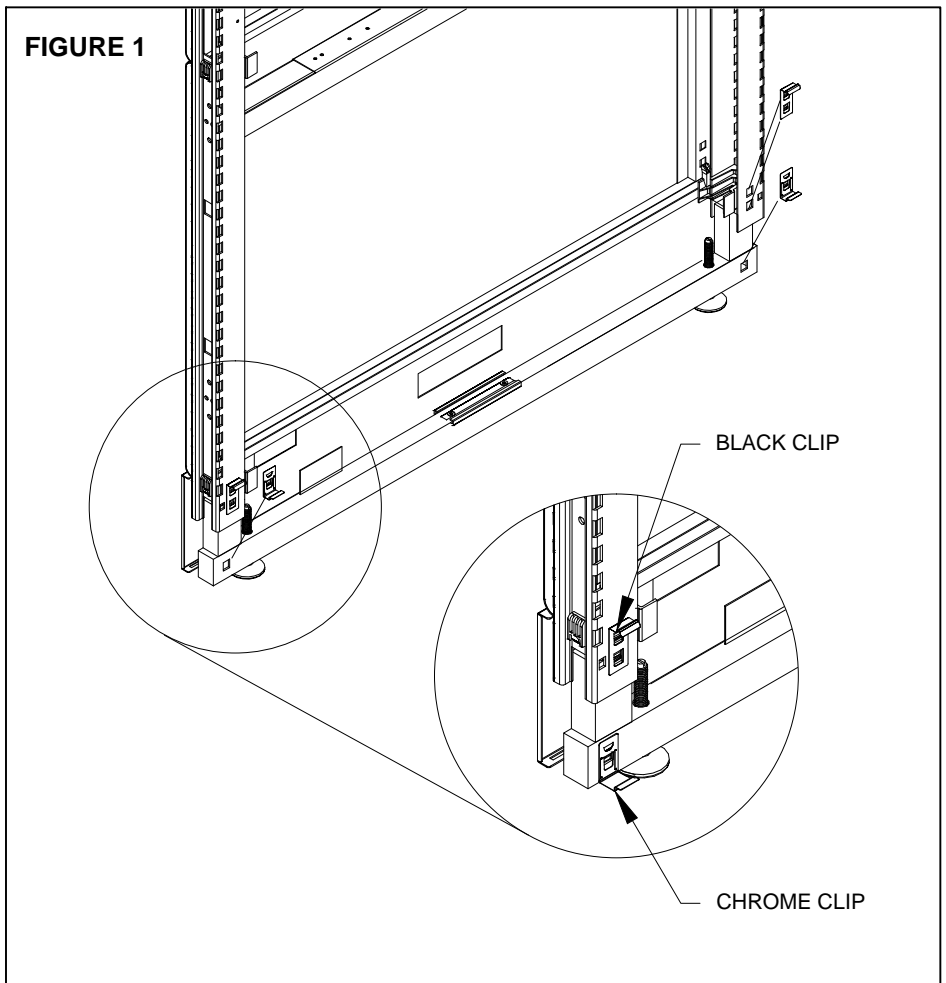

panel kickplate installation (cont'd)

4. Re-install the previously removed tiles, (Figure 3).

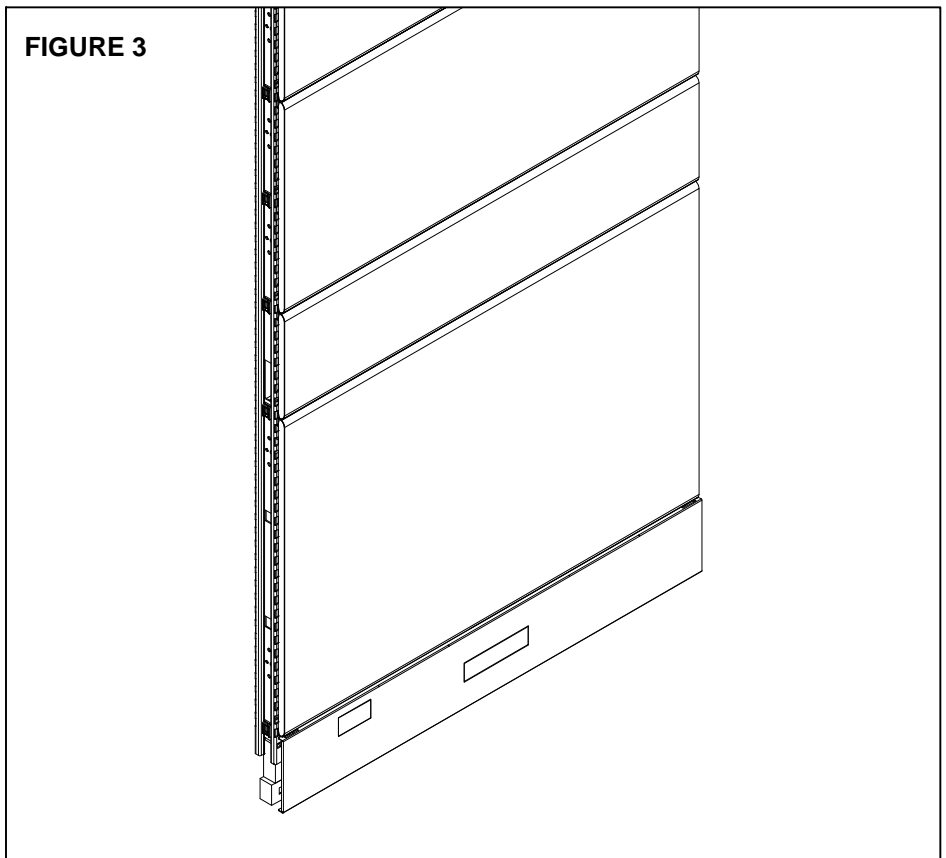

NOTE:

- > Prior to installing kick plates verify if electrics are at the bottom of the panel frame. If so make sure the knockouts on the kick plate are punched out. Also installers should complete a kick plate installation prior to installing clips to other panels.

hardware needed

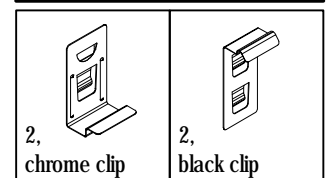

panel top trim & end trim installation

1. Sort out all top trims and end trims according to panel frame size, (Figure 1).
2. All panel frames and end trims will have the top and end trim springs pre installed for installation, (Figure 2).
3. Install the top trim connectors, on both sides of the top trim, and on the top of the end trim, (Figure 3).

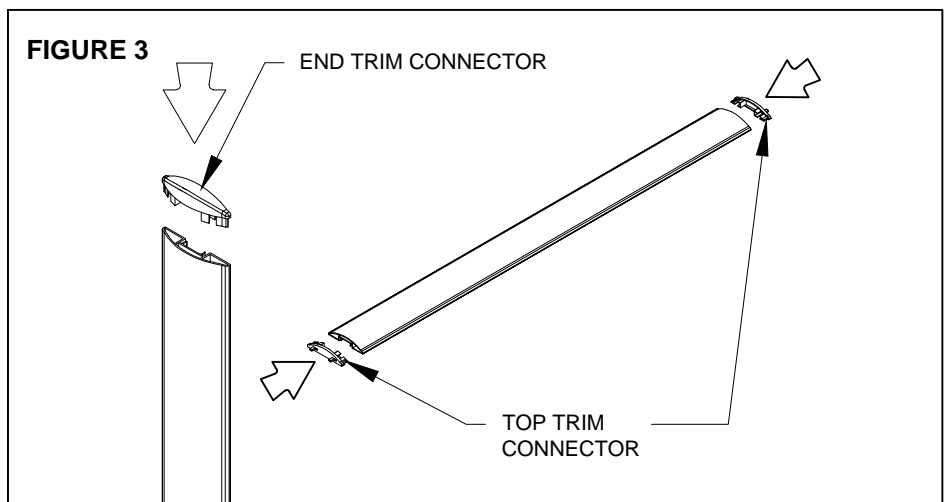
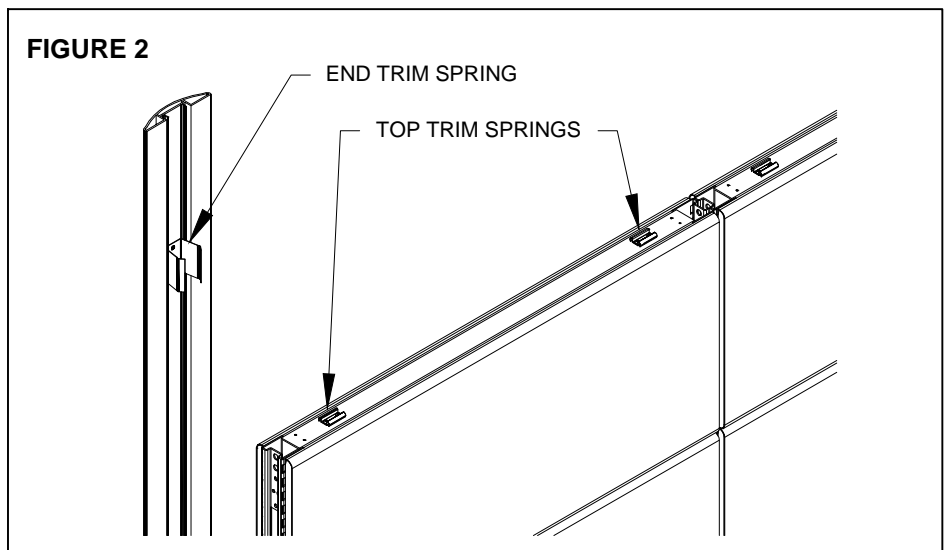
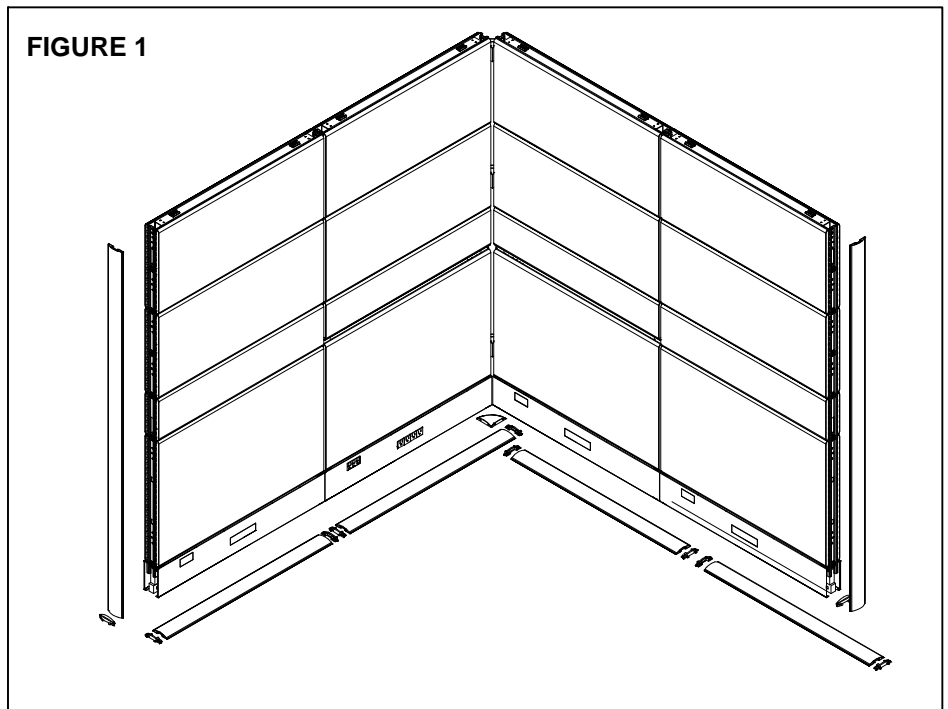

panel top trim & end trim installation (cont'd)

4. Due to the trim connectors, the top and end trims can only be installed in sequence. Start off at one end of the panel run, and end at the other panel run, (Figure 4, 5, 6, & 7). Also install the top caps where appropriate, (Figure 5).

FIGURE 4

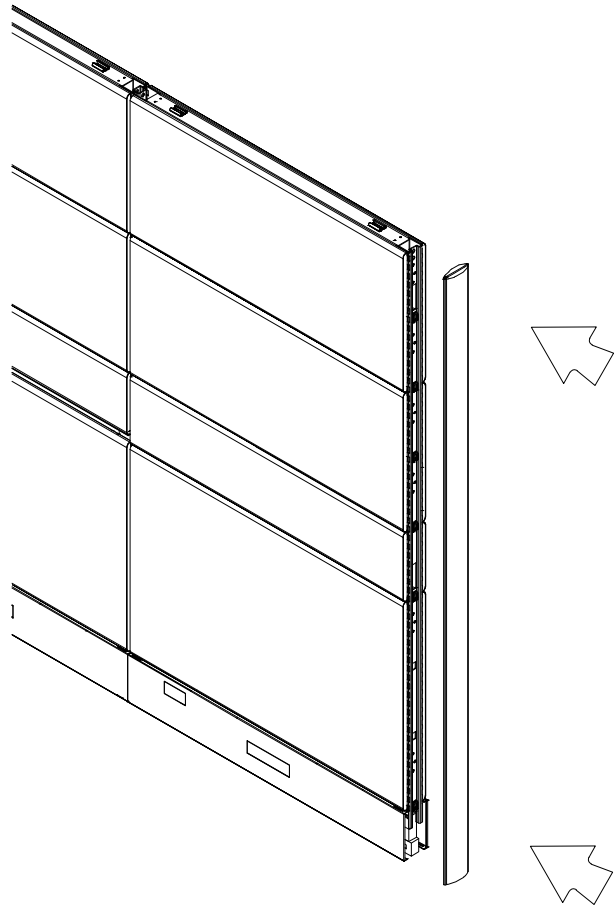
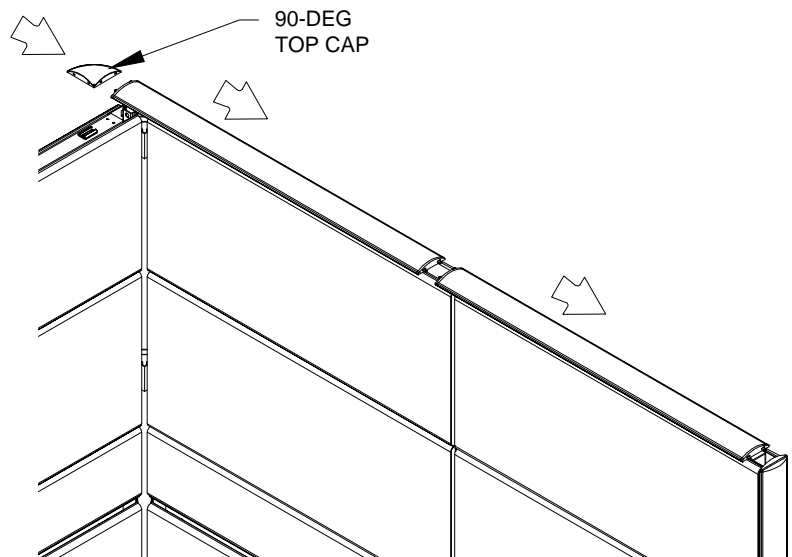

FIGURE 5



panel top trim & end trim installation (cont'd)

5. For variable height panel frames use partial end trims (Figure 8). They need to have two trim connectors, one at the top (top trim connector) and one at the bottom (partial end trim connector) of the end trim.

FIGURE 6

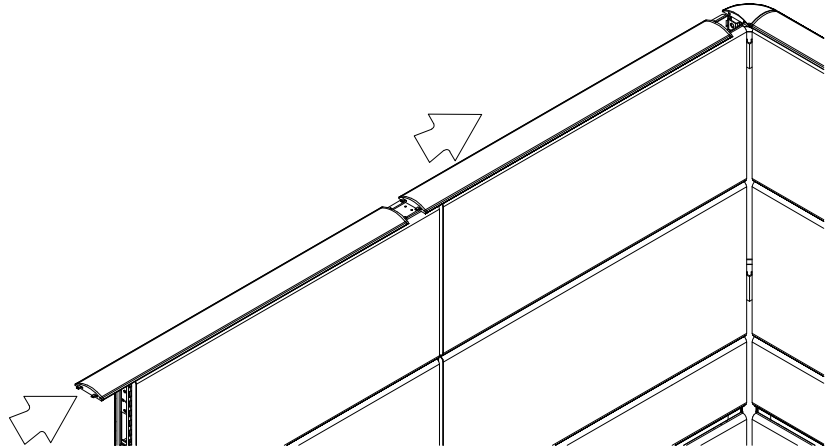
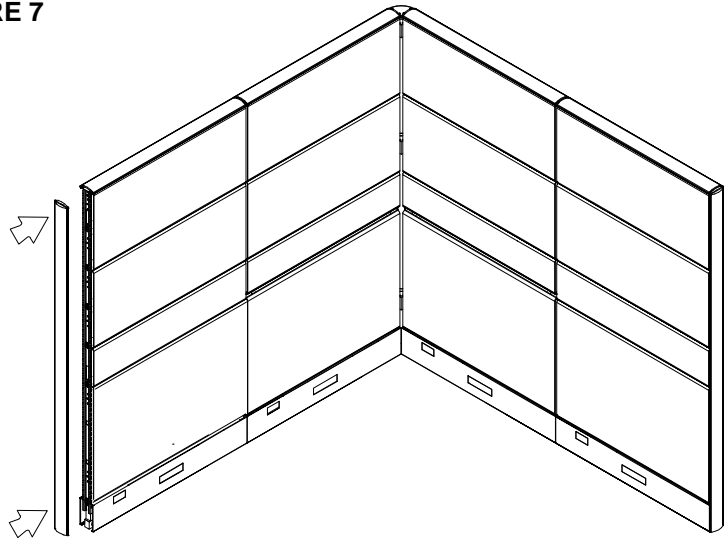

FIGURE 7



NOTES:

- > View all the variable height panel combinations to see what top trims, top caps and end trims are necessary for different panel configurations.
- > If your order consists of reception countertops, you will receive top trims with two punched out holes on either end measuring 1 3/4-inches. Please install it at its applicable location.

FIGURE 8

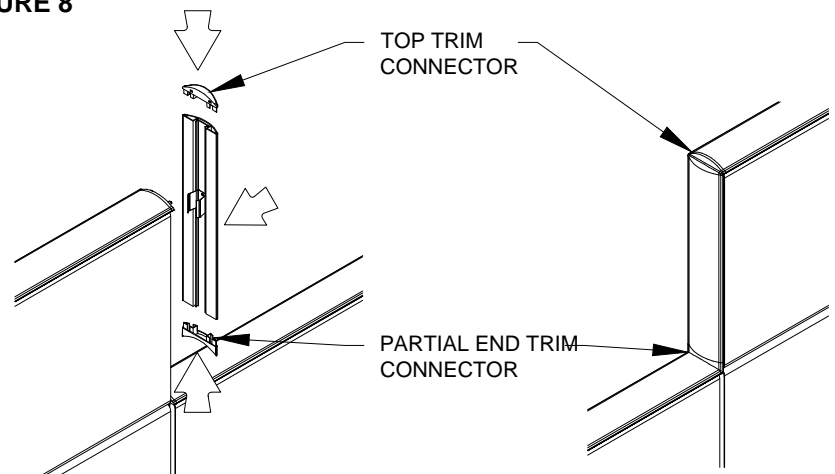

panel filler installation

1. Distribute all the fillers at their appropriate location.
2. Line up the fillers with the top caps. Tap the fillers into the frame connectors using a rubber mallet, so the fillers will snap into the frame connectors. Then work your way down from top to bottom.

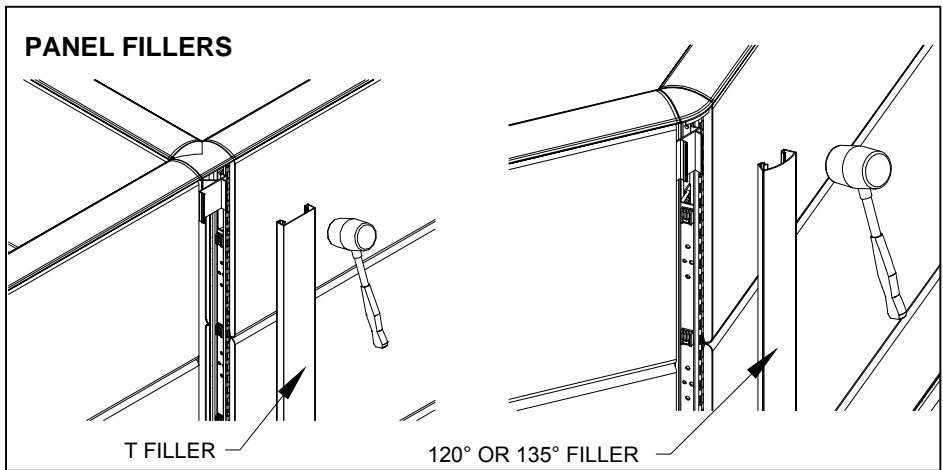
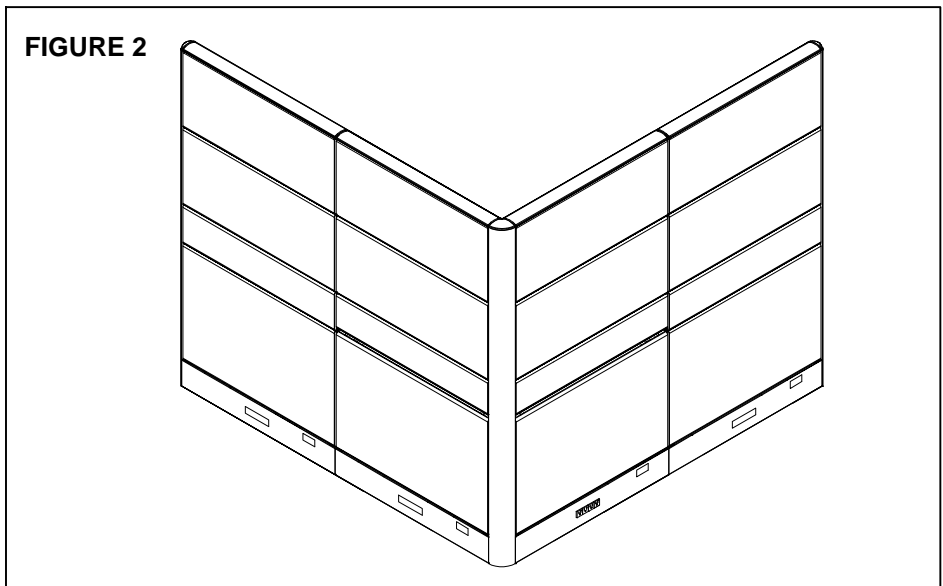
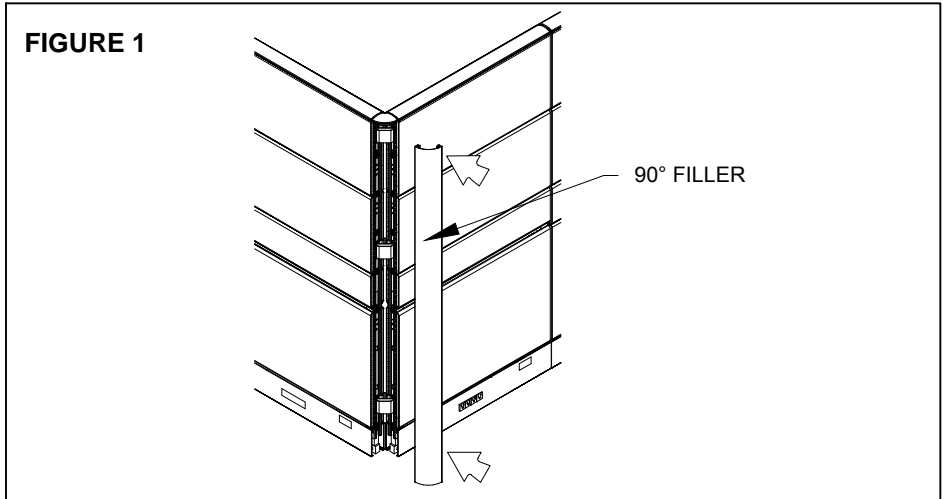

NOTES:

- > View all the variable height panel combination to see what fillers are necessary for different panel configurations.
- > If fillers do not stay in place or sliding down, remove fillers and gently tap out edges on connectors that hold fillers in place.

tool needed



panel tile installation

1. Install the stainless steel springs and grey tile hooks into the slots, (Figure 1).
2. Figure 2 shows the placement of the stainless steel springs.

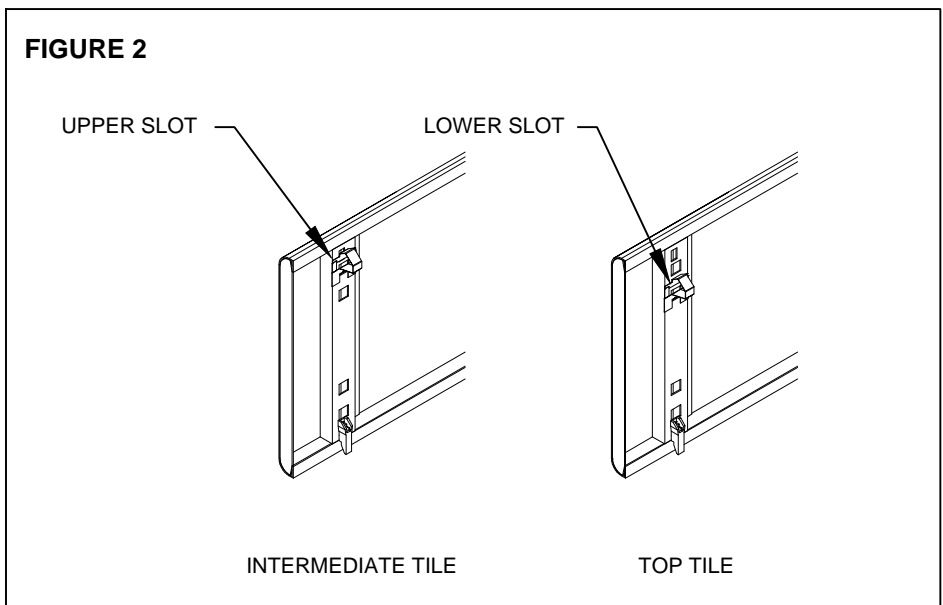
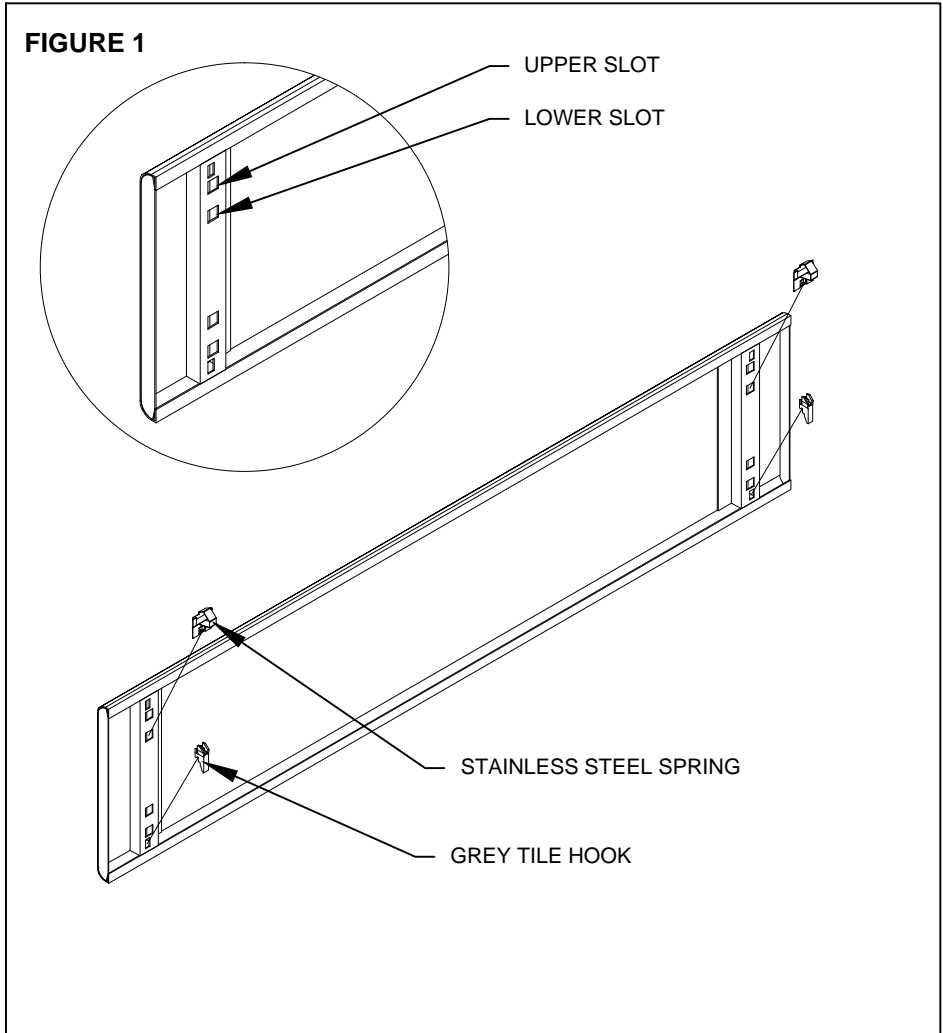

panel tile installation (cont'd)

3. Lay the two bottom clips on the top of the "vinyl clip on tile", then raise the tile until the two top springs clip on the bottom of the upper "clip on tile", (Figure 3).
4. All top tiles will clip on the welded U brackets on the top of the panel frame, (Figure 4).

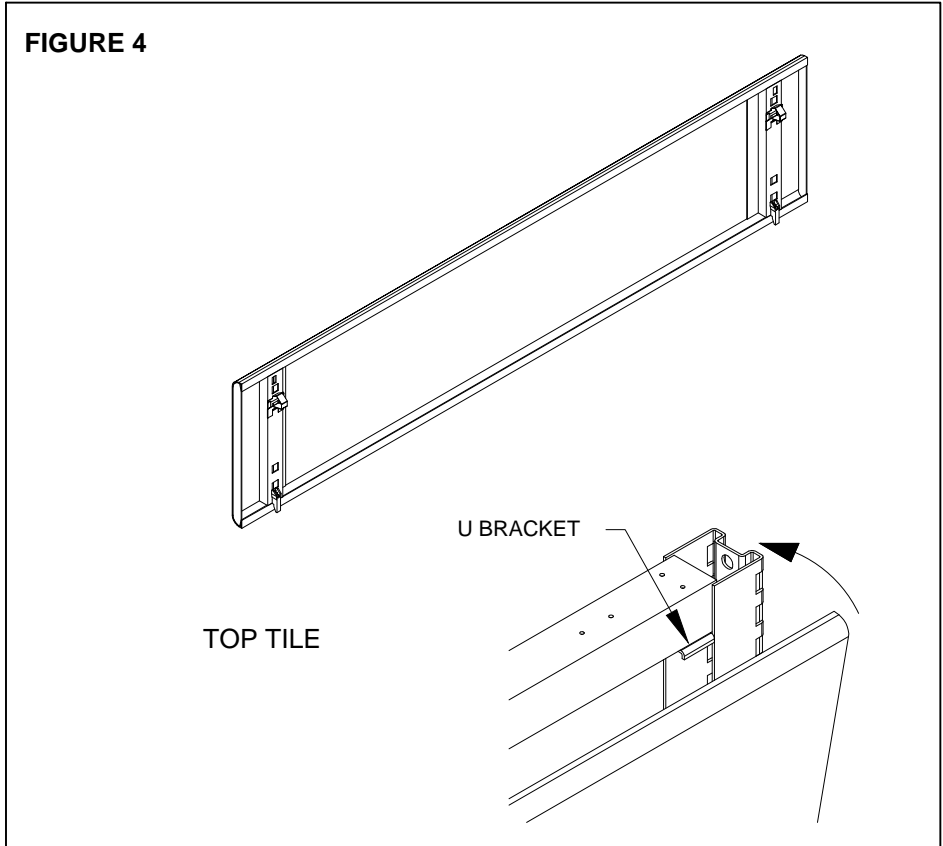
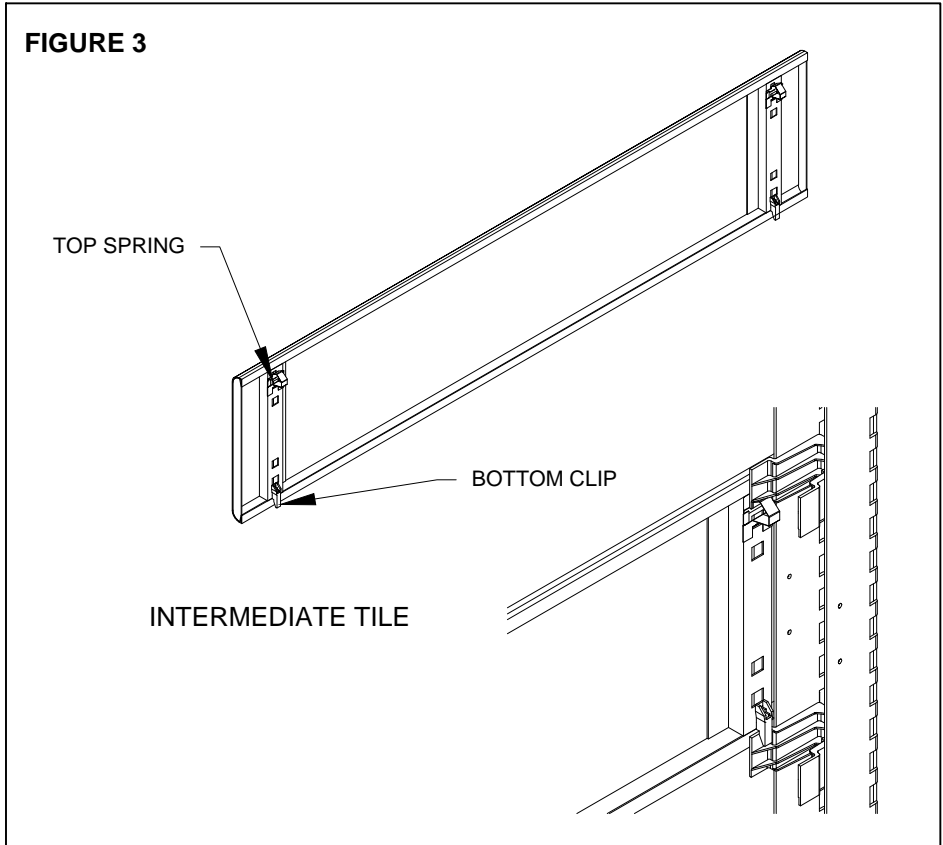

panel tile installation (cont'd)

5. Figure 5 shows panel frame with tiles.

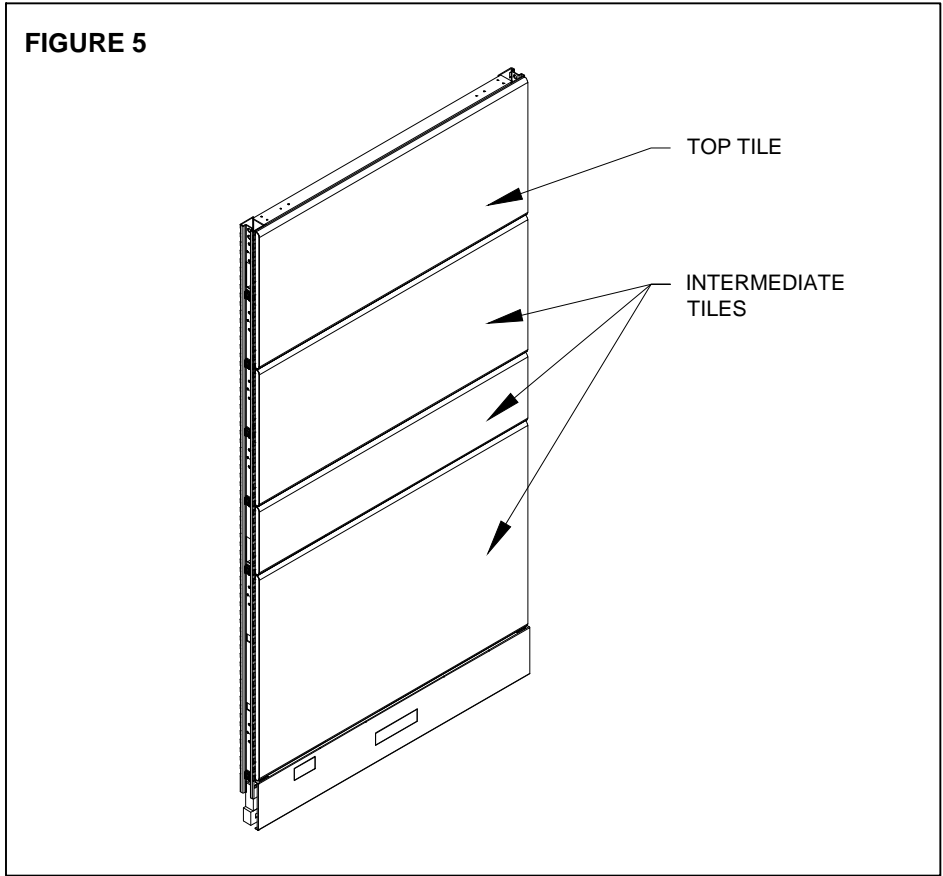

panel acrylic tile installation

1. Lay the two bottom clips on the top of the "vinyl clip on tile", then raise the tile until the two top springs clip on the bottom of the upper "clip on tile", (Figure 1).
2. All top tiles that are glazed will clip on the welded U brackets on the top of the panel frame, (Figure 2).

FIGURE 1

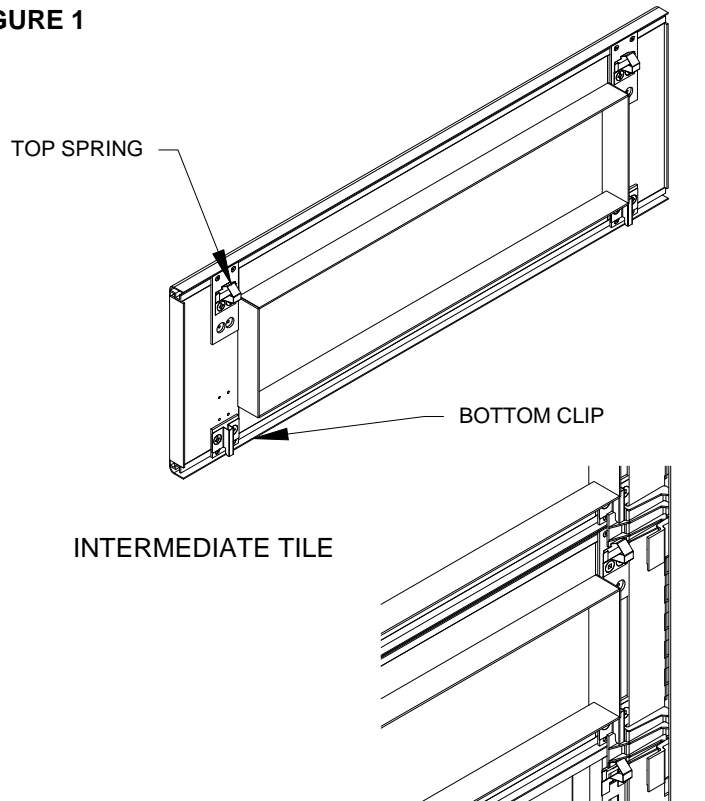
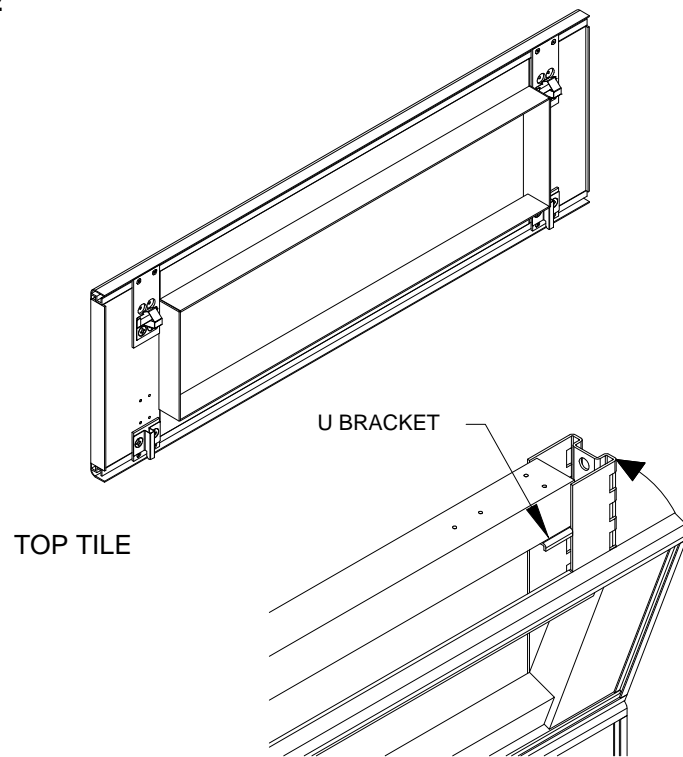
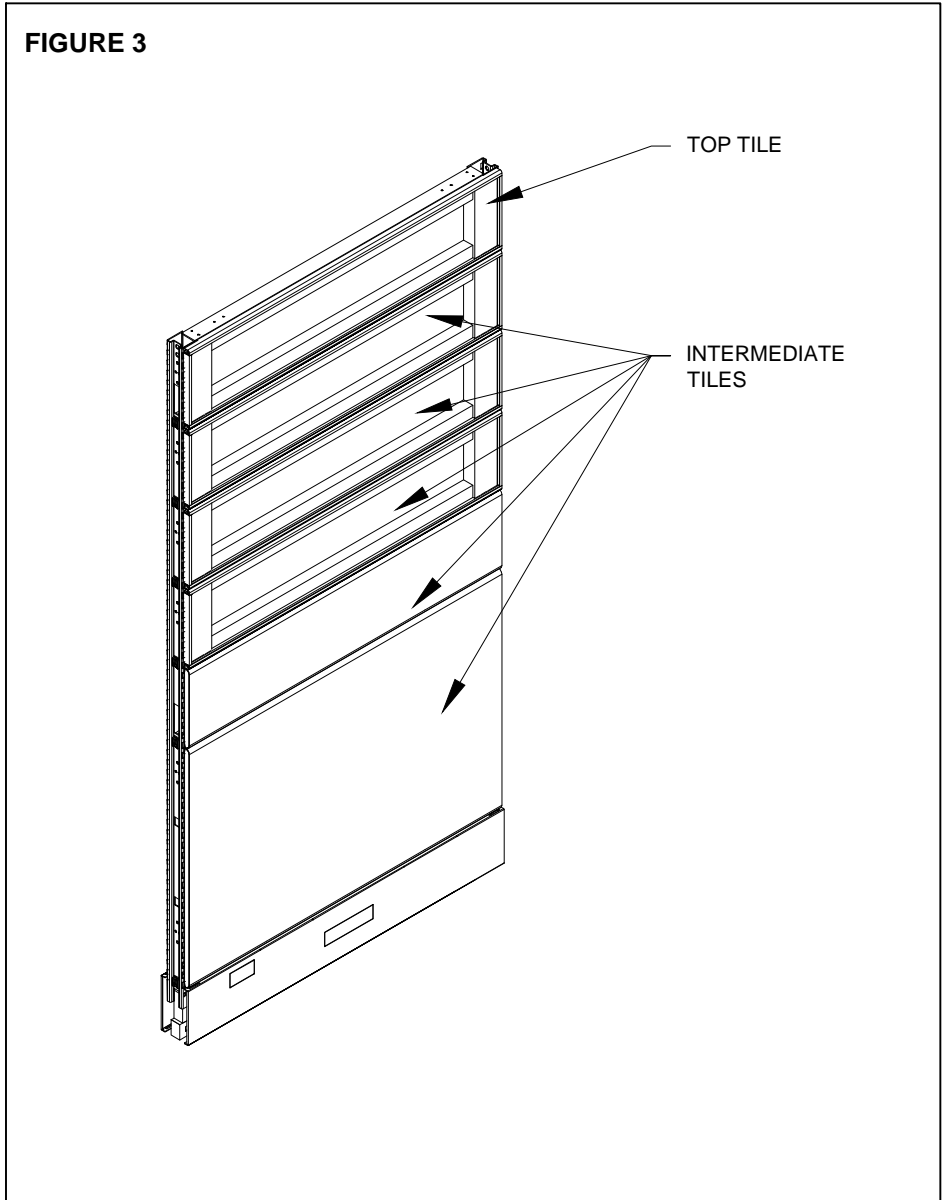

FIGURE 2



panel acrylic tile installation (cont'd)

3. Figure 3 shows panel frame with glazed tiles.



monolithic tile removal

1. Remove the top trim and end trims, and the kick plate if necessary, (Figure 1).
2. Lift from the middle bottom of the tile 1/2-inch up and pull away the panel, in order to disengage the keyholes, (Figure 2).

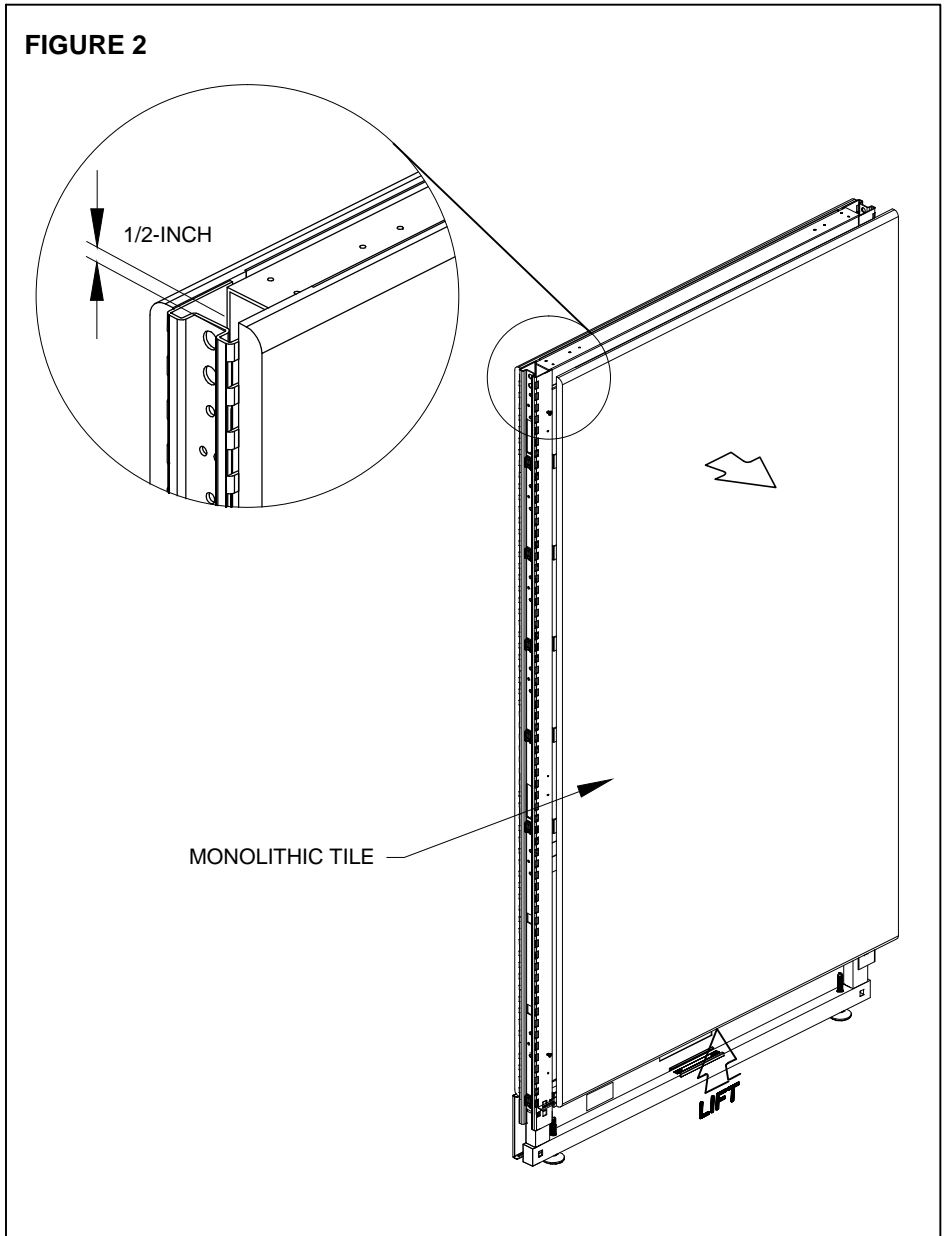
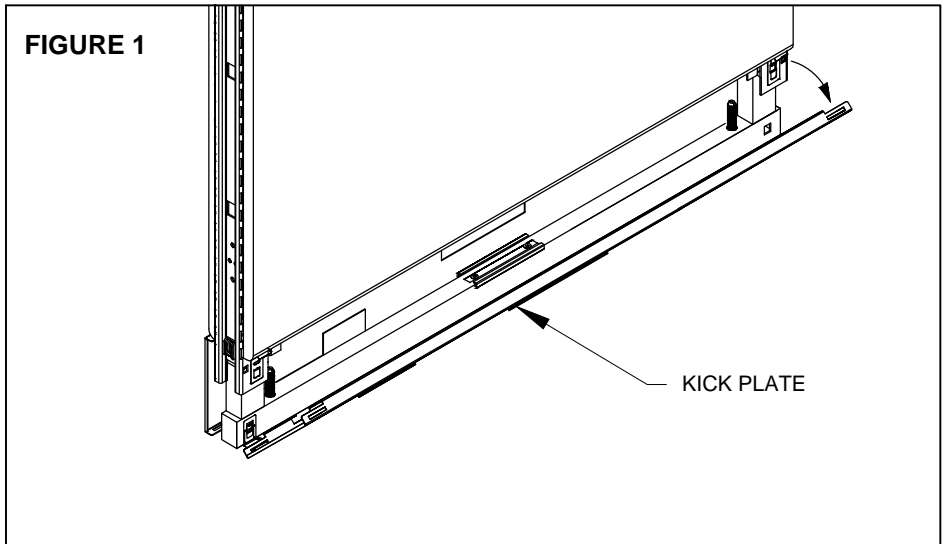

monolithic tile installation

1. Figure 1 shows the back panel of the monolithic tile and panel frame.

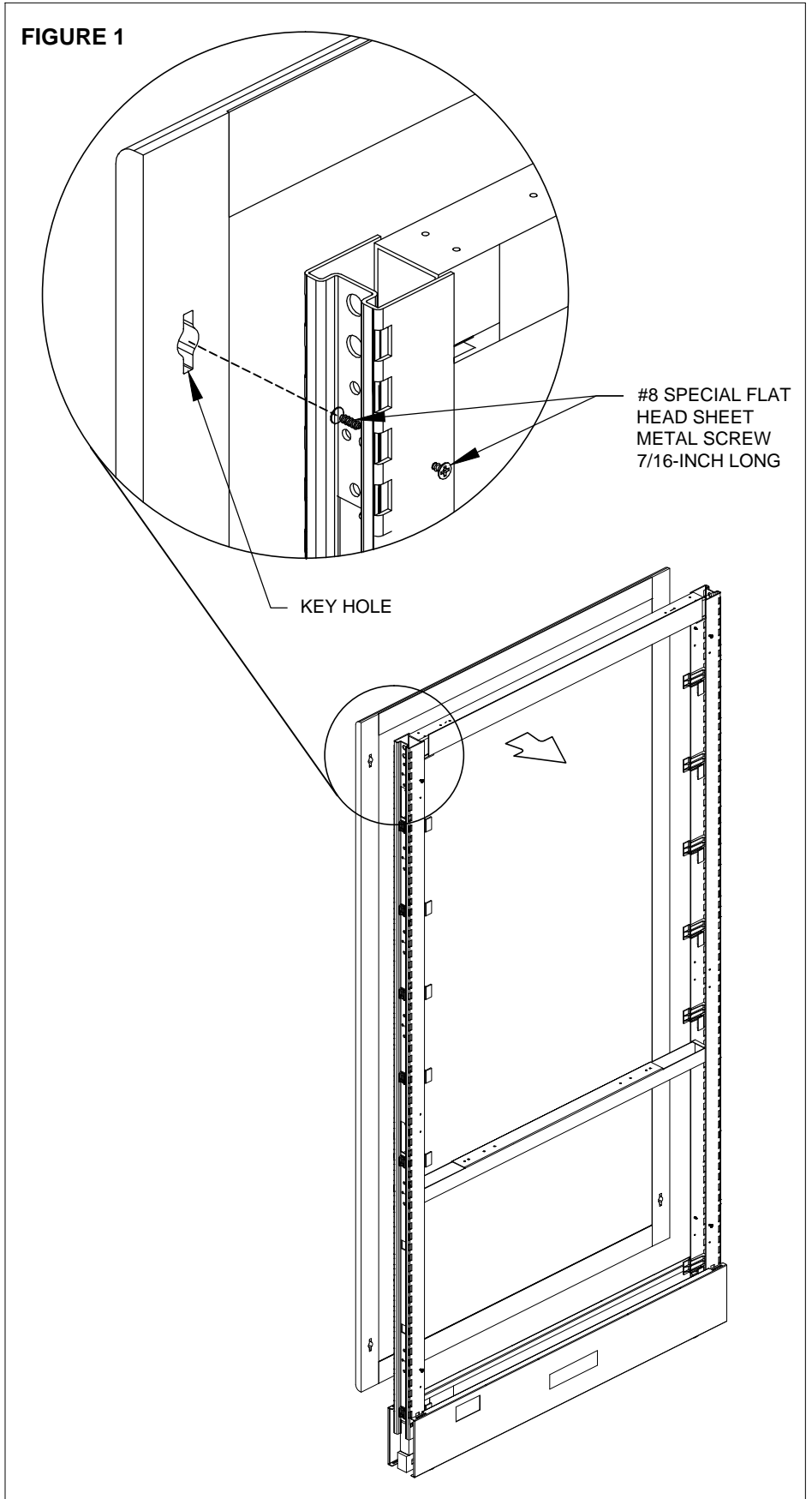

monolithic tile installation (cont'd)

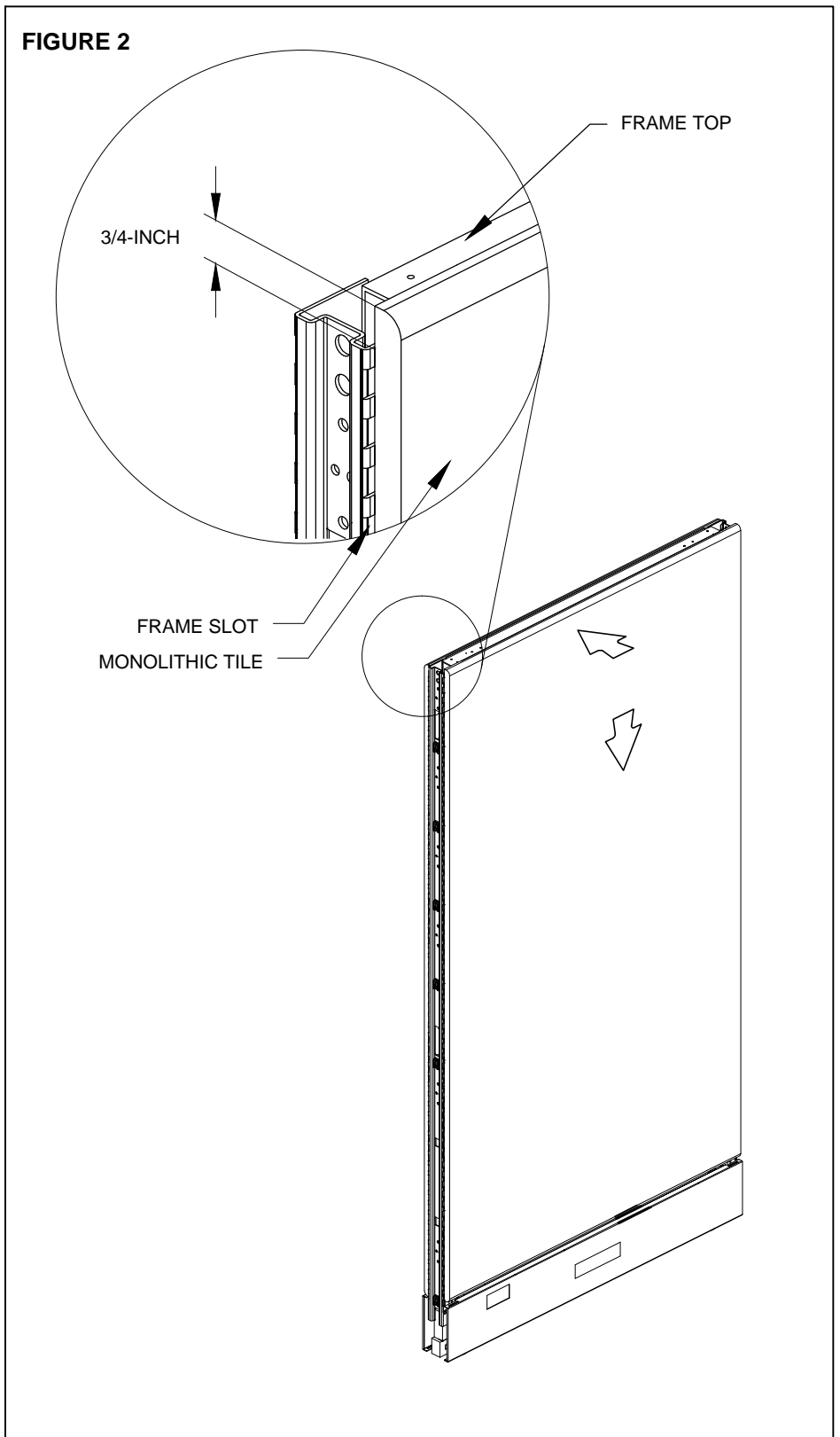

NOTE:



- > Make sure all keyholes are engaged.

surface level access door installation

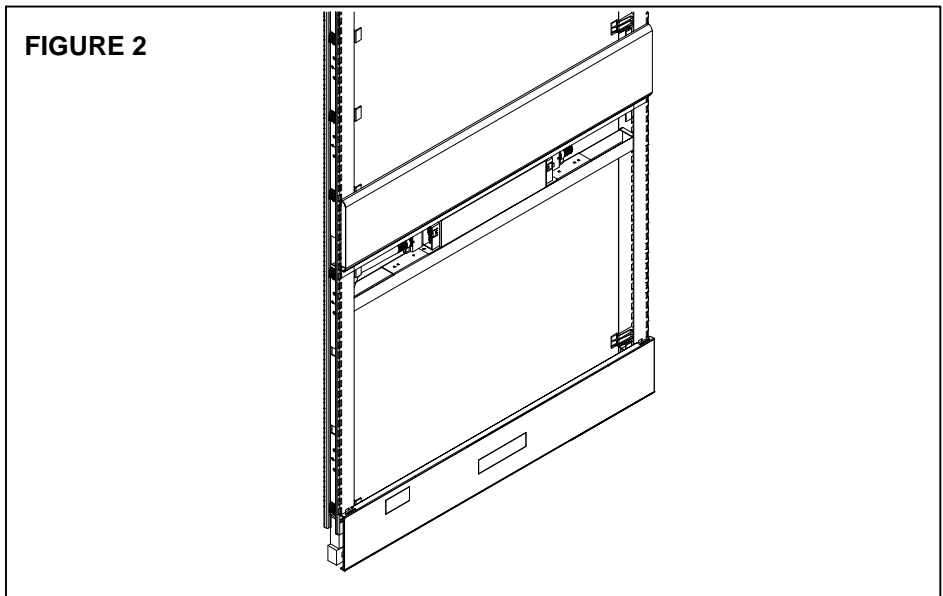
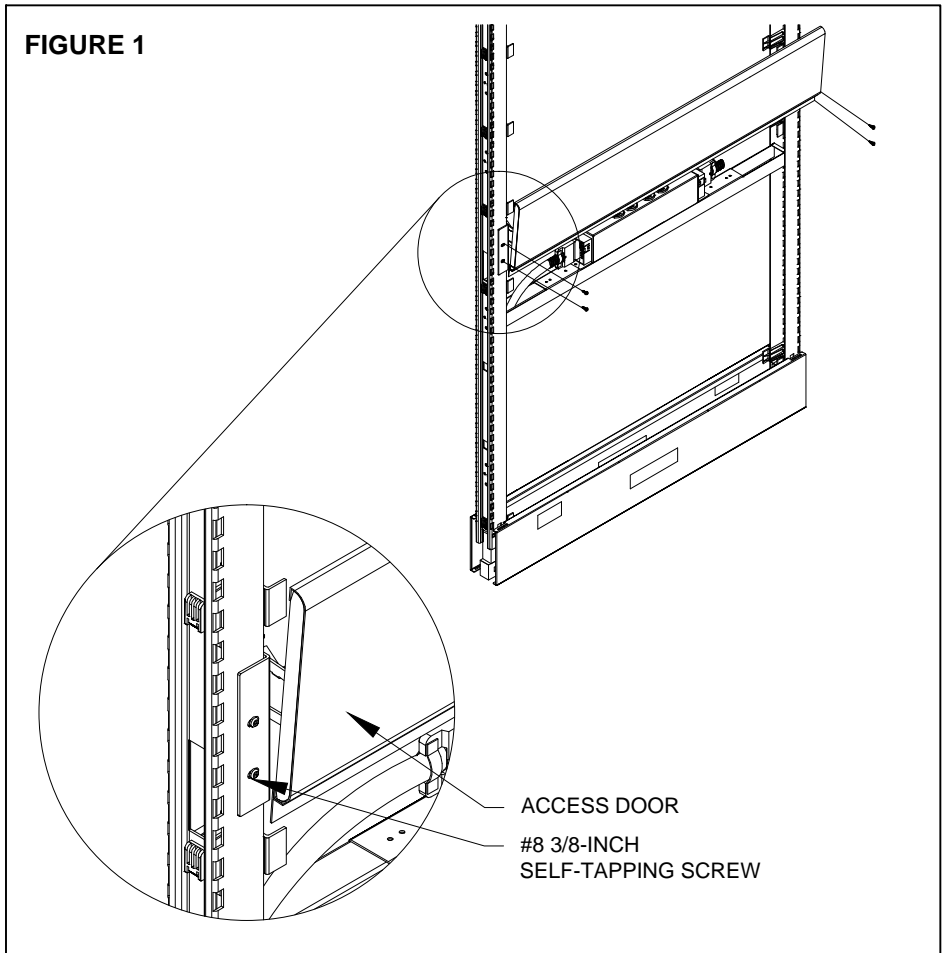
1. The access door tile will be pre-assembled by Tayco, prior to shipping.
2. On the panel frame there are two pilot holes starting at 31 3/4-inches. Install the self tapping Robertson screws #8, 3/8-inch with washer provided through the access door plate into the panel frame, adjust vertically and horizontally to line up with upper tiles and then tighten, (Figure 1). Slide the door down to close and verify if any other adjustments are required, (Figure 2).

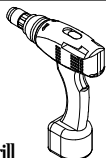
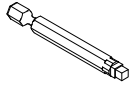

tools & hardware needed

 drill	 #3 Robertson bit	 4, #8 3/8" self tap screw	 4, 1/2" washer
---	---	---	--

workspace installation

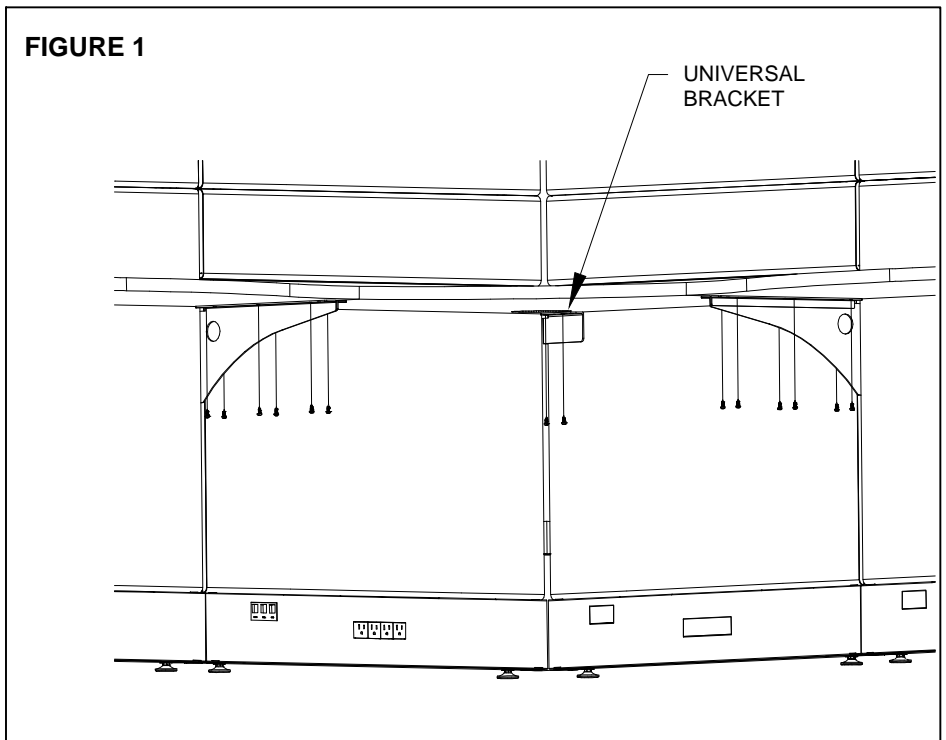

1. Position surfaces over supports. Ensure that universal bracket is supporting corner surfaces.
2. Make sure surfaces are in a snug position. Screw the surfaces together using the support holes as a guide with 11/16-inch, oval head screws, using #2 Robertson bit, (Figure 1).
3. The last step would be to insert grommet covers into the surface.



NOTE:

- > For the adjustable keyboard installation please refer to the "Installation Guide" that comes with the keyboard.

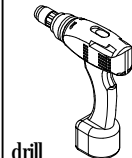
tools & hardware needed

 drill	 #2 Robertson long bit	 11/16" oval head screw
--	---	--

slot stopper installation

Slot stoppers are used to reduce vertical movement of the surface.

1. If there is an existing end filler, remove it first, (Figure 1).
2. Place a black stopper by pushing it down onto the bracket, (Figure 2).
3. Slide the black slot stopper into the slot, (Figure 3).
4. Re-install the end filler.

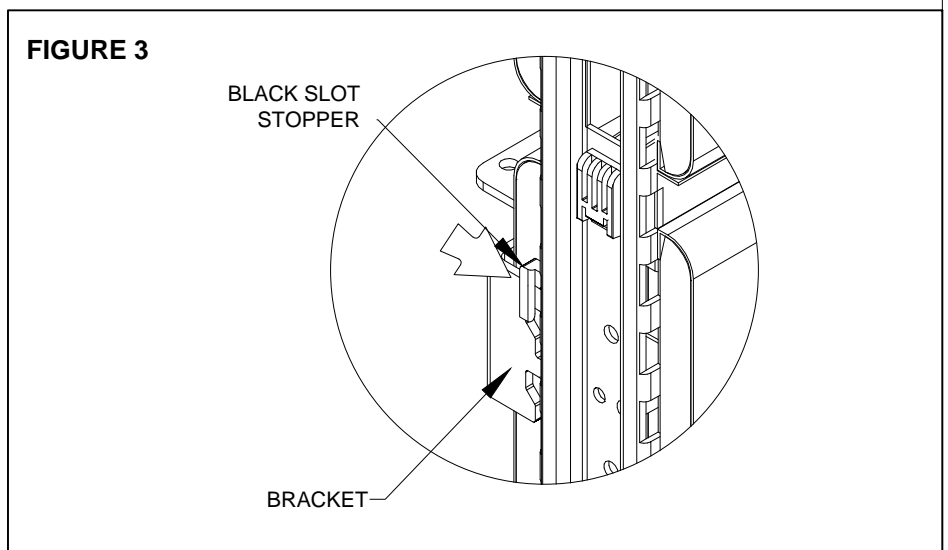
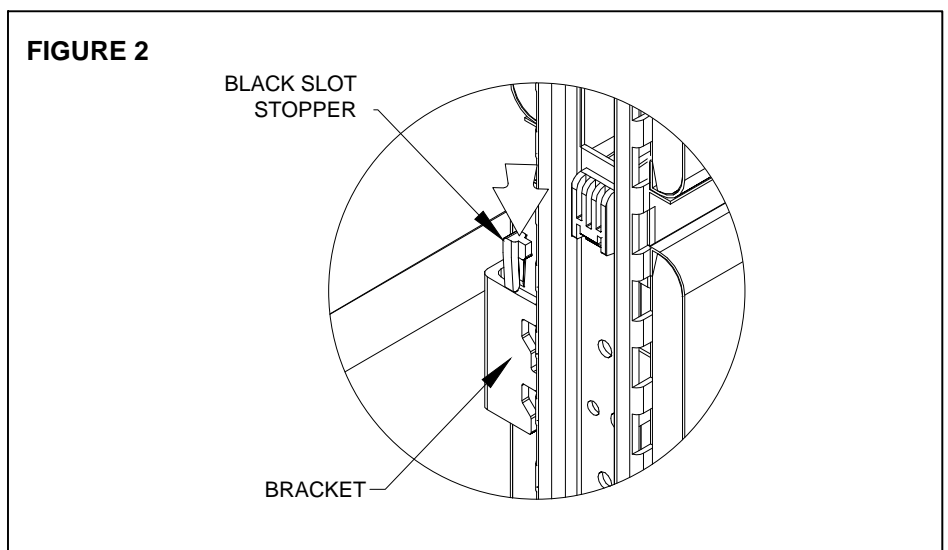
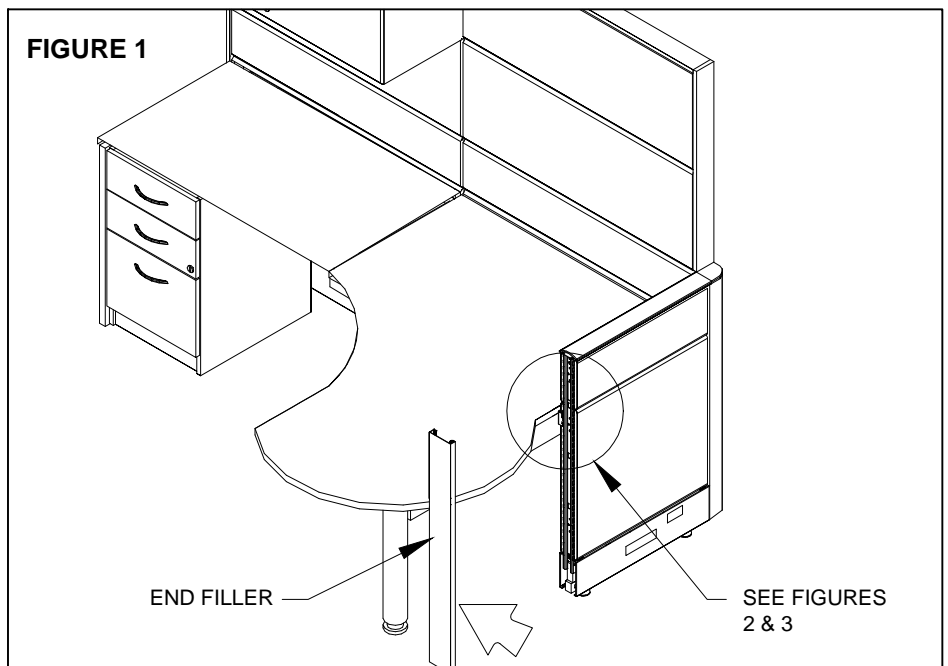

NOTE:

- > Place the black slot stopper on end of run only.

glazed countertop installation

1. Locate where the glazed countertop is being installed. This can be easily identified by locating the top trims that have 1 3/4-inches holes pre-drilled through them.
2. Remove the the top panel tiles on both sides of the panel. Insert the 2 1/2-inches head machine screws through the pre-drilled holes in the panel frame from bottom to top.
3. With one hand holding the hexagon screw at the bottom, insert the glazed counter support on top and twist on tight.
4. Place the correct size tempered glass on top of the glazed countertop supports, then insert the threaded knobs and hand tighten clockwise to the glass.
5. Re-install the top panel tiles, (Figure 2).

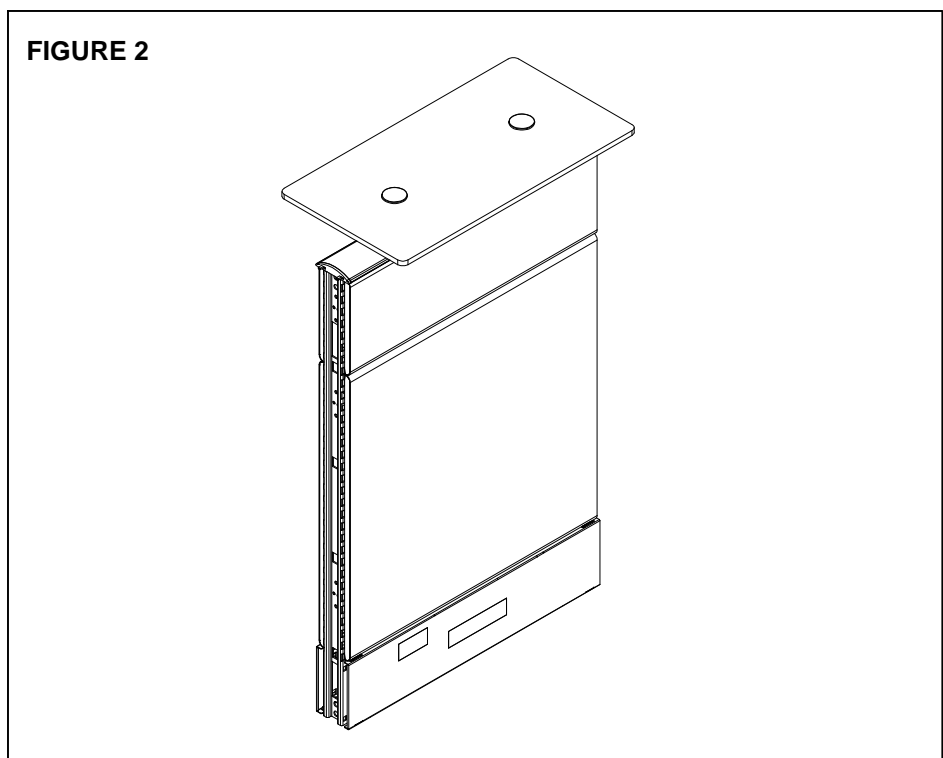
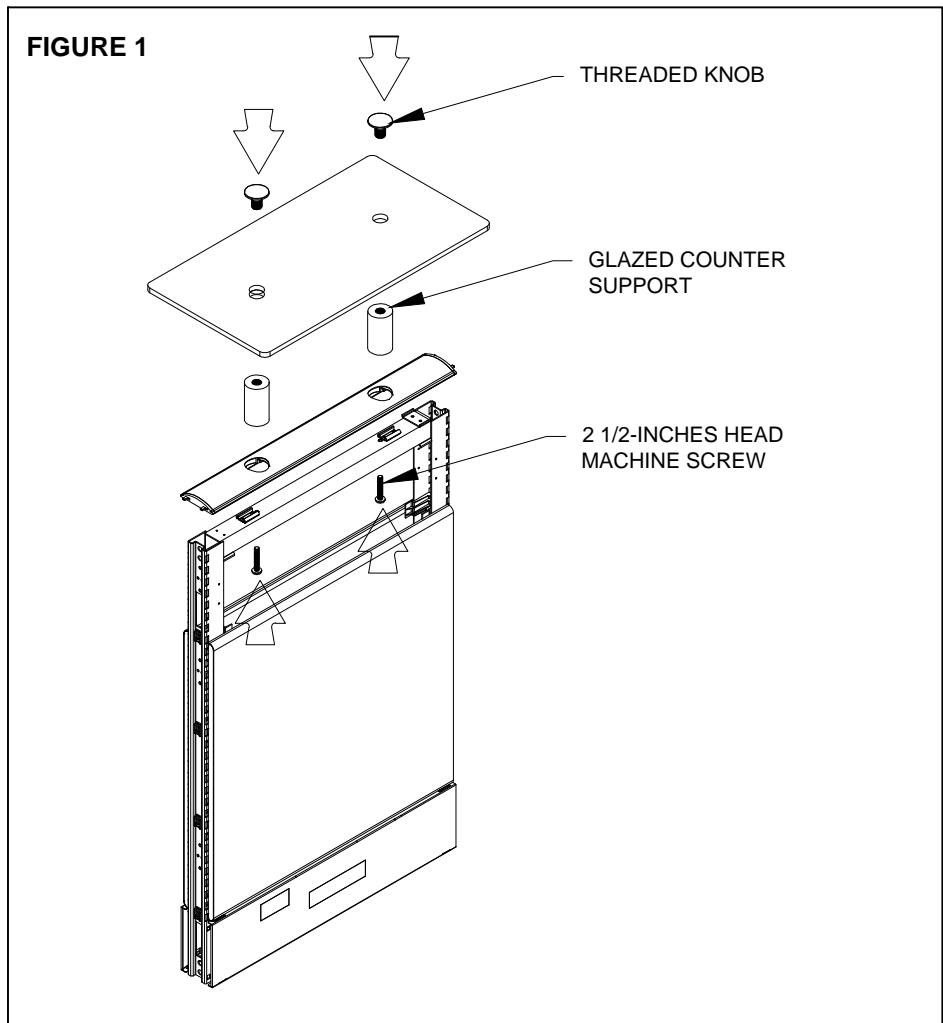

laminite counter top installation

1. Identify the panels where the laminate counter tops are located from the floor plan.
2. Remove the top panel tiles on both sides of the panel and install the panel trims with holes, (Figure 1).
3. Secure the laminate counter top posts to the panel. With one hand holding the hexagon screw at the bottom, insert the counter top support on the top trim and twist on tight, (Figure 2).
4. Align the laminate counter tops centered and parallel to the posts, having both sides 5-inches from the edge of the laminate to the metal plate on the post and secure using #10 11/16 oval head screws per post, (Figure 3, 5).

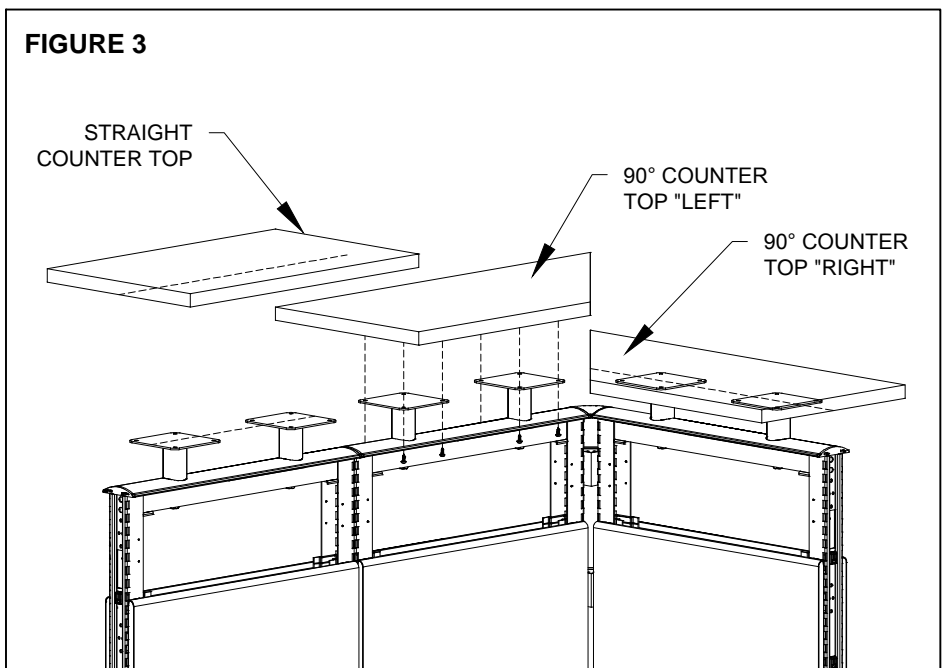
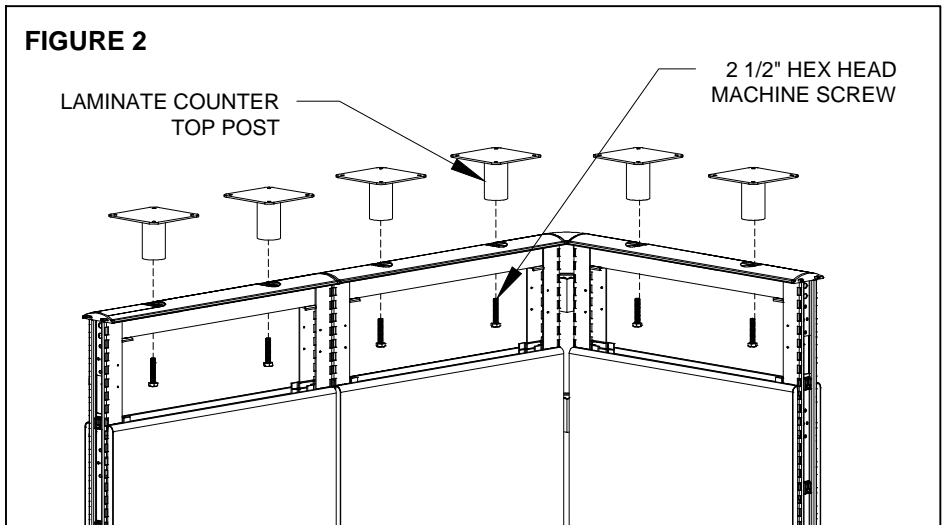
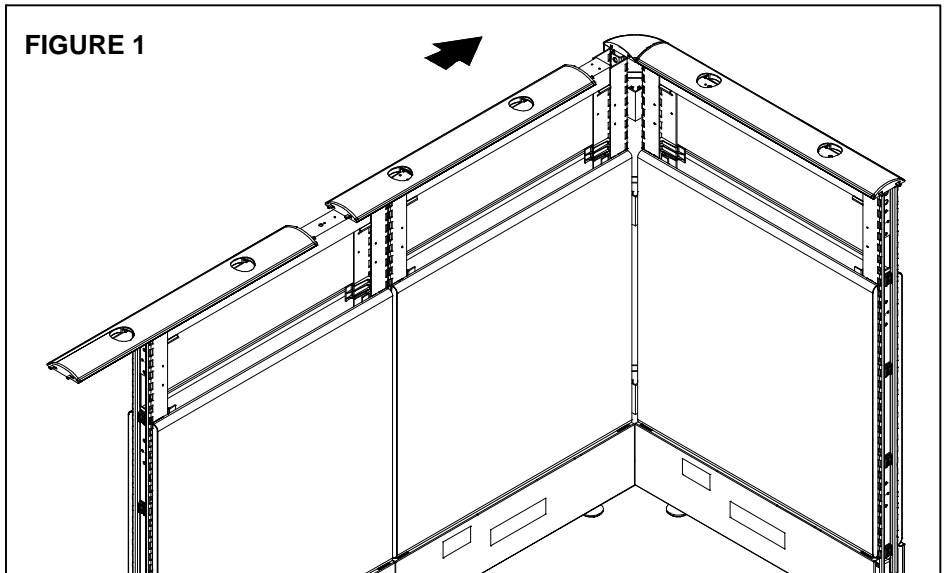

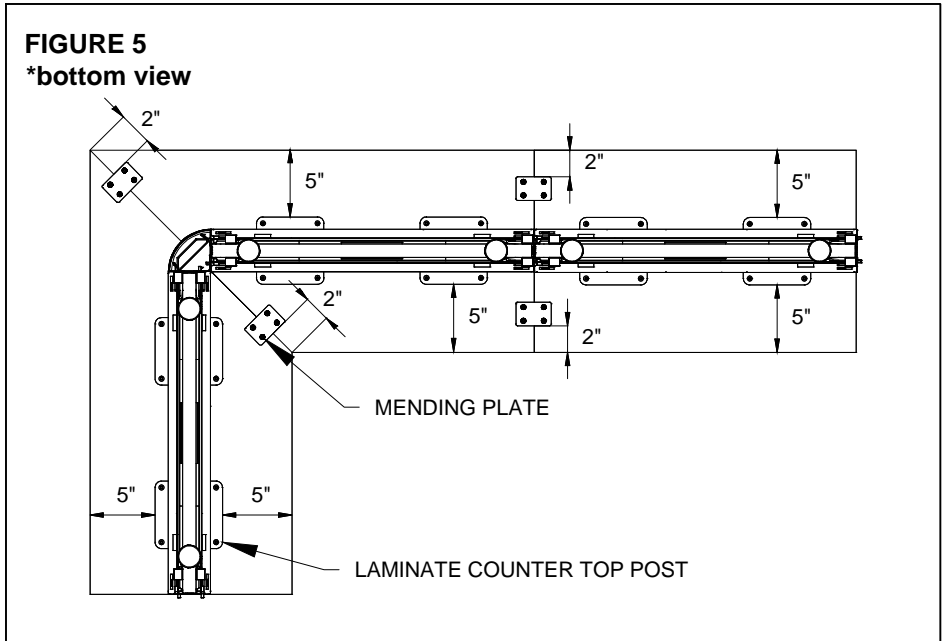
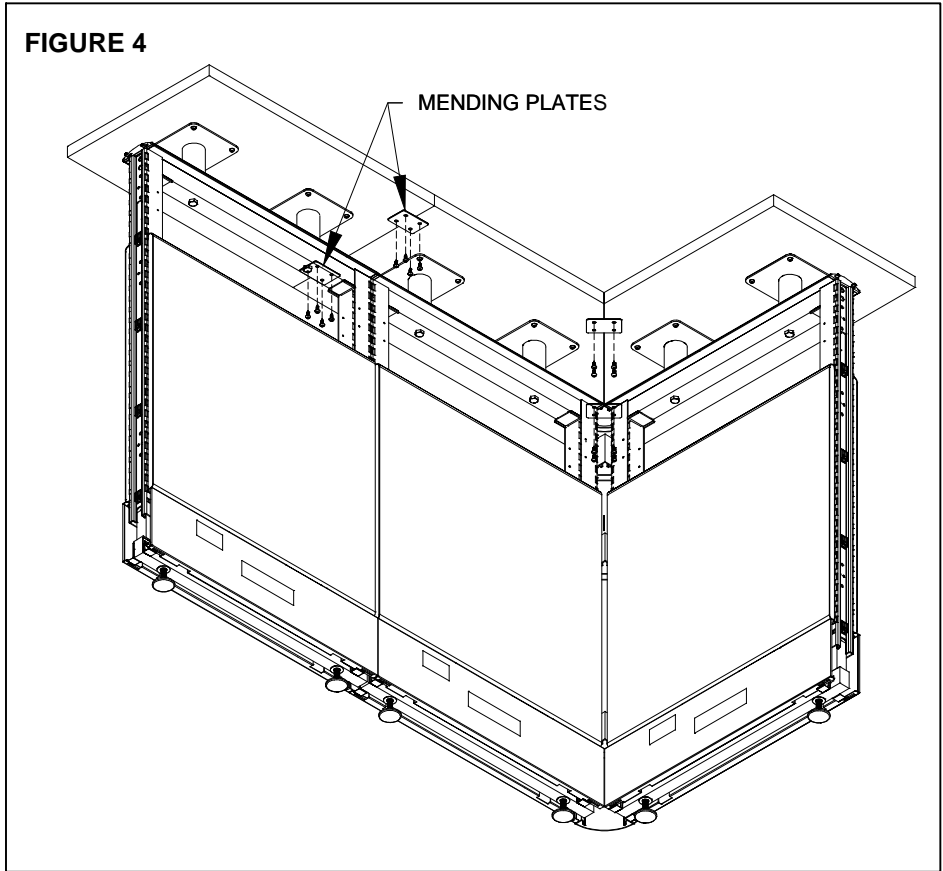

laminite counter top installation (cont'd.)

5. With all laminate counter tops secured; install two mending plates for every laminate counter top connection; 2-inches from the edge of the counter tops using #10 11/16 oval head screws, (Figure 4,5).
6. Re-install the top panel tiles.

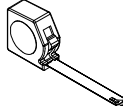
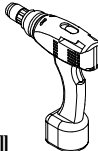
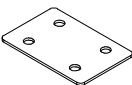

tools & hardware needed

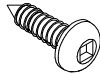
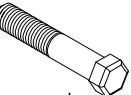
 measuring tape	 drill	 mending plate	 #2 robertson long bit	 4 per post/plate, #10 11/16" oval head screw	 1 per post, 2 1/2" hex head machine screw
---	--	---	--	---	--

worksurface support installation - cantilever & bracket

1. Distribute all supports (cantilever and bracket) at their proper location.
2. Measure from the bottom of the panel frame up to 27-inches in height or count the slotted frame channel (23 in total), (Figure 1).
3. Insert the cantilever support by angling it at 30 degrees; place the support hook into the slotted frame channel, release it down and the support will be engaged, (Figure 2). There are two types of cantilever supports: one that joins two surfaces together (intermediate cantilever support), and the other one is for end runs, and it can be left and right sided, (Figure 3).

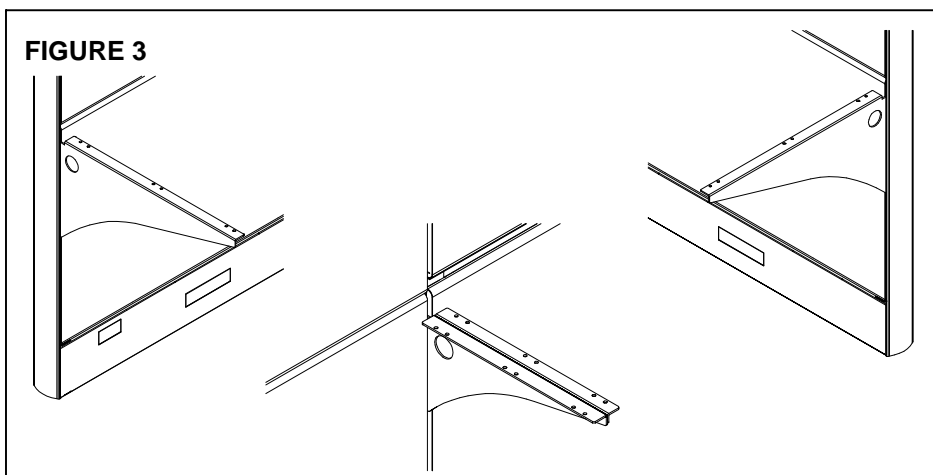
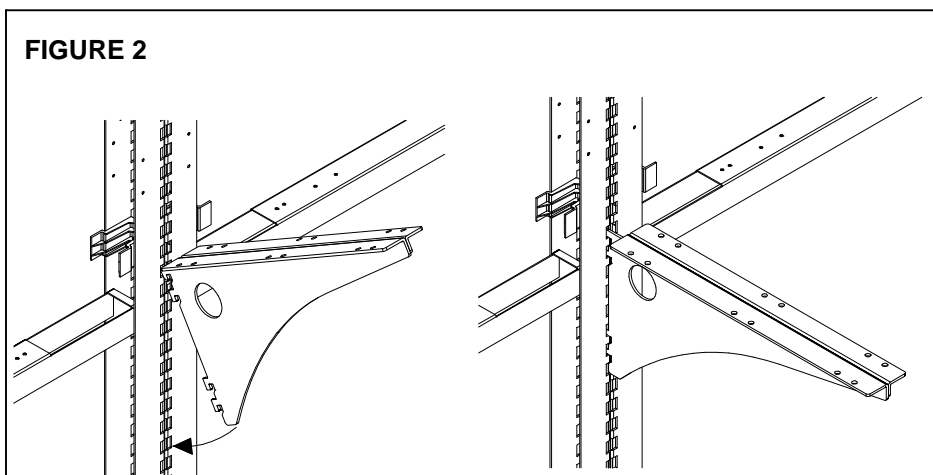
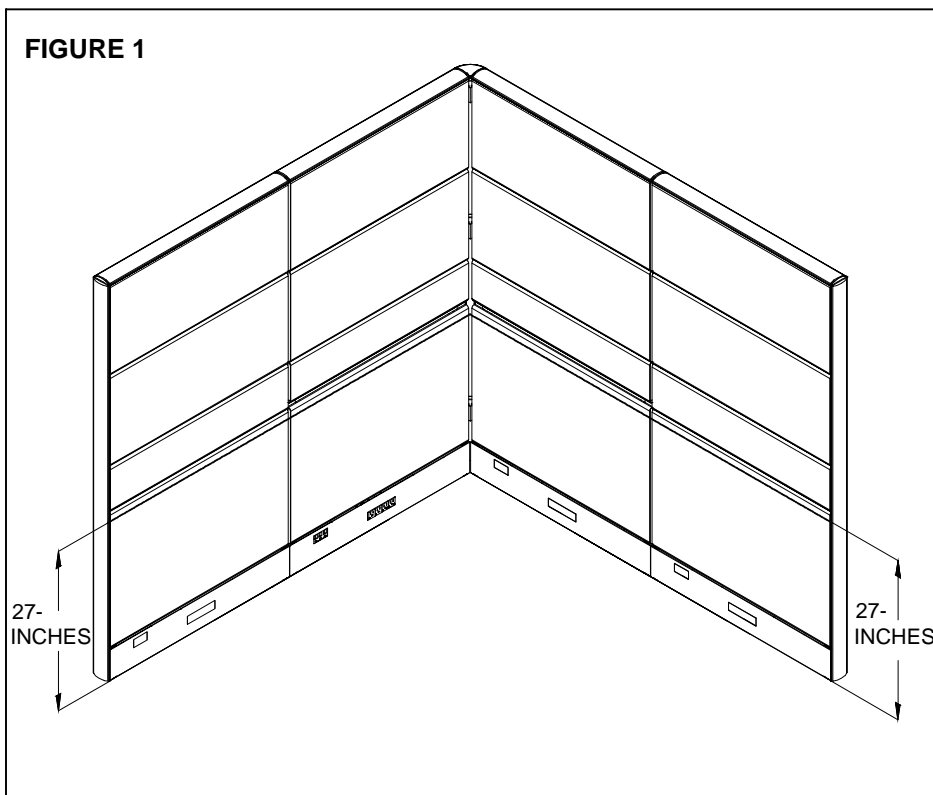

worksurface support installation - cantilever & bracket (cont'd)

4. Proceed in the same way as stated above to install the universal brackets. They are primarily used for corner surfaces, (Figure 4); or for panel end runs, when a return panel at the end run is required (used a left and a right sided bracket in this case), (Figure 5).

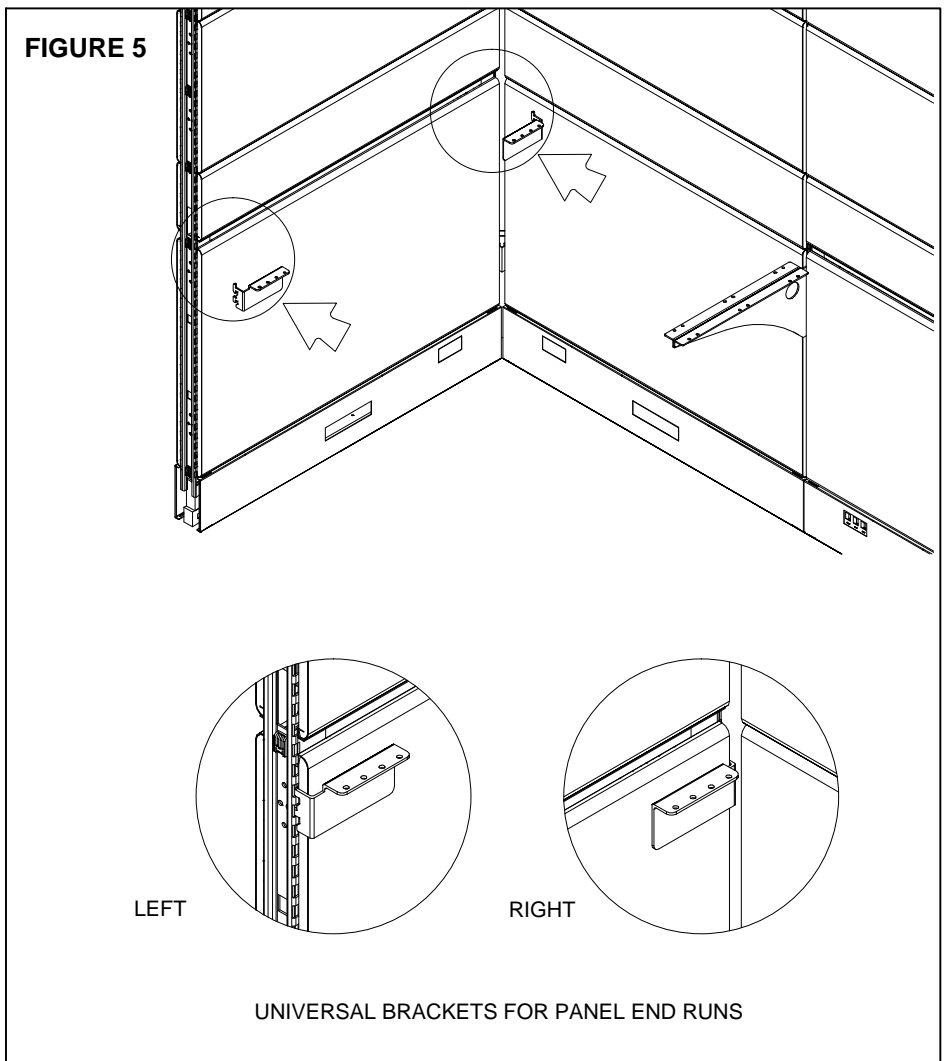
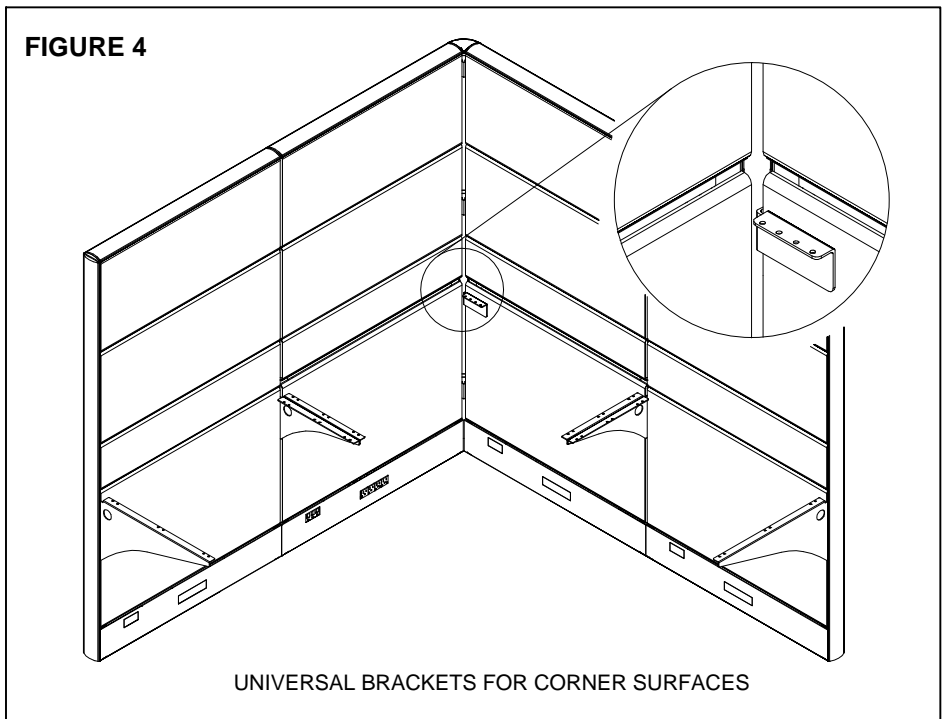

NOTE:

- > Surfaces do not need mending plates for attachments, as their supports have welded plates on top for attaching surfaces.

worksurface support installation - end gable

End gables are attached to panel frames with end gable brackets (two per end gable) that come in left or right.

1. Measure up to 24-inches in height from the bottom of the panel for the upper gable bracket. The lower gable bracket is to measure from the bottom of the panel up to 8 inches.
2. Insert the end gable brackets by angling them at 30 degrees; place the gable bracket hook into the slotted frame channel, release it down and the gable brackets will be engaged, (Figure 1).
3. Attach two 90-degree brackets to the gable, with four, 11/16-inch oval head screws using #2 Robertson bit, (Figure 2).

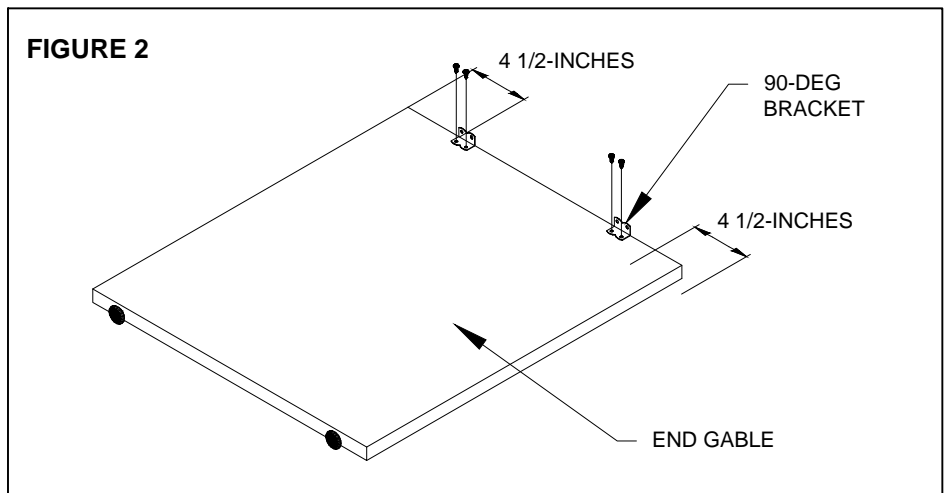
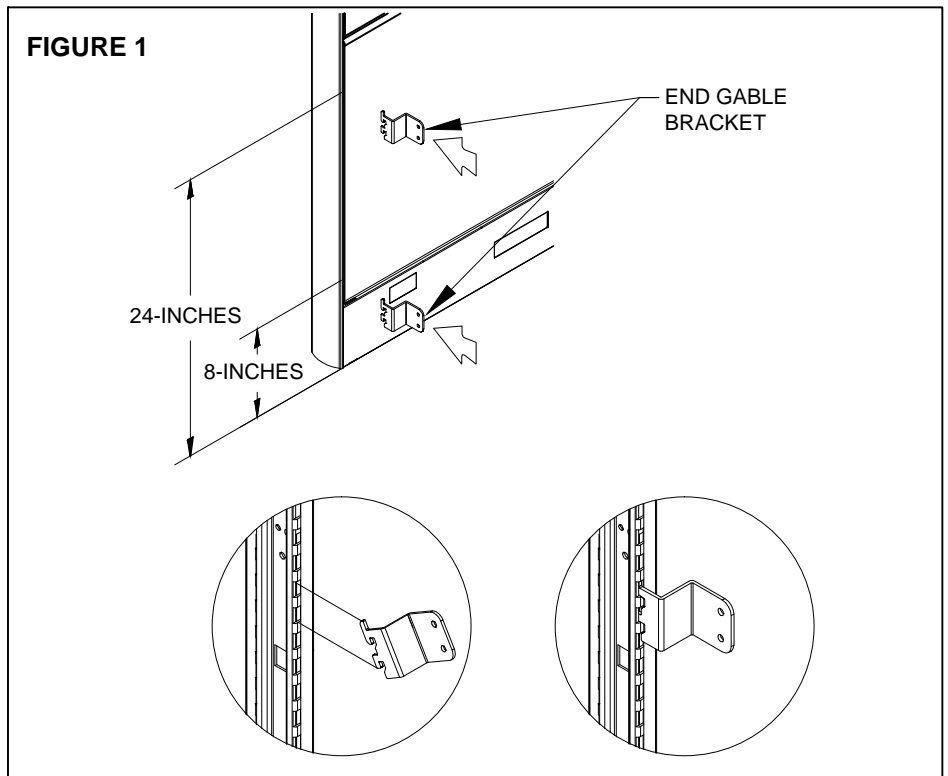



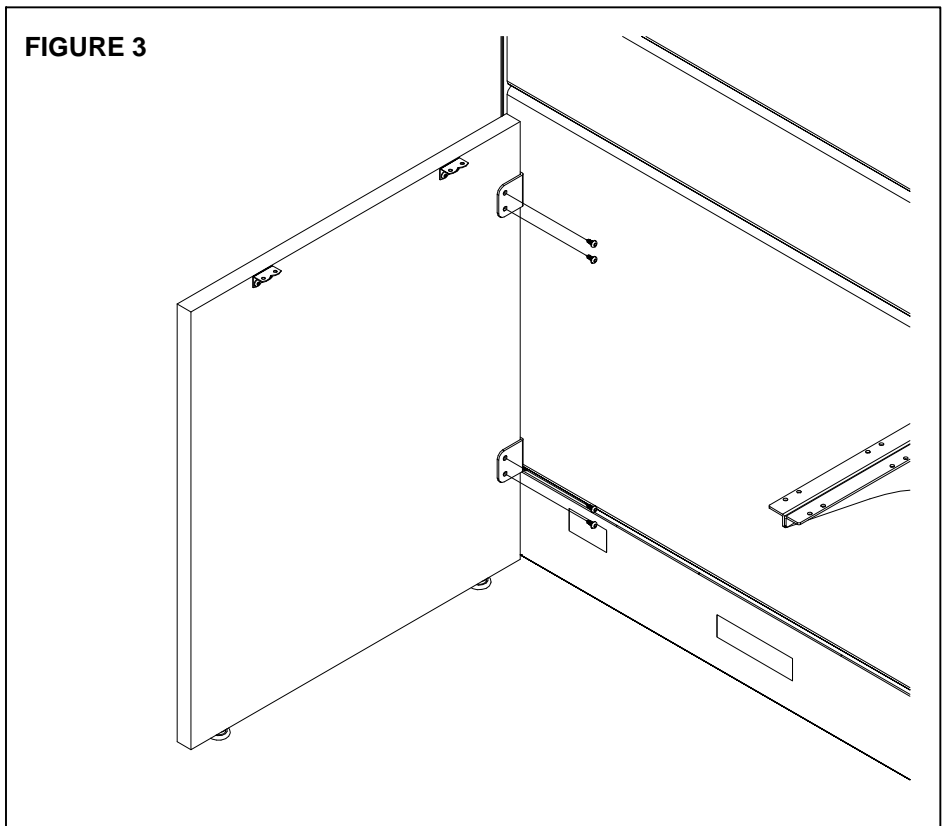

worksurface support installation - end gable (cont'd)

4. Position the gable into place; level and adjust glides if necessary.
5. Attach the gable to the gable brackets on the panel with four, 11/16-inch oval head screws, using #2 Robertson bit, (Figure 3).

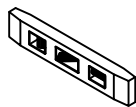
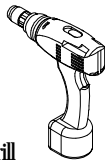

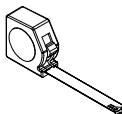
tools & hardware needed

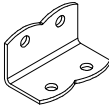
					
torpedo level	drill	#2 Robertson bit	measuring tape	8, 11/16" oval head screw	2, 11/16" oval head screw

worksurface support installation - reinforcement bar

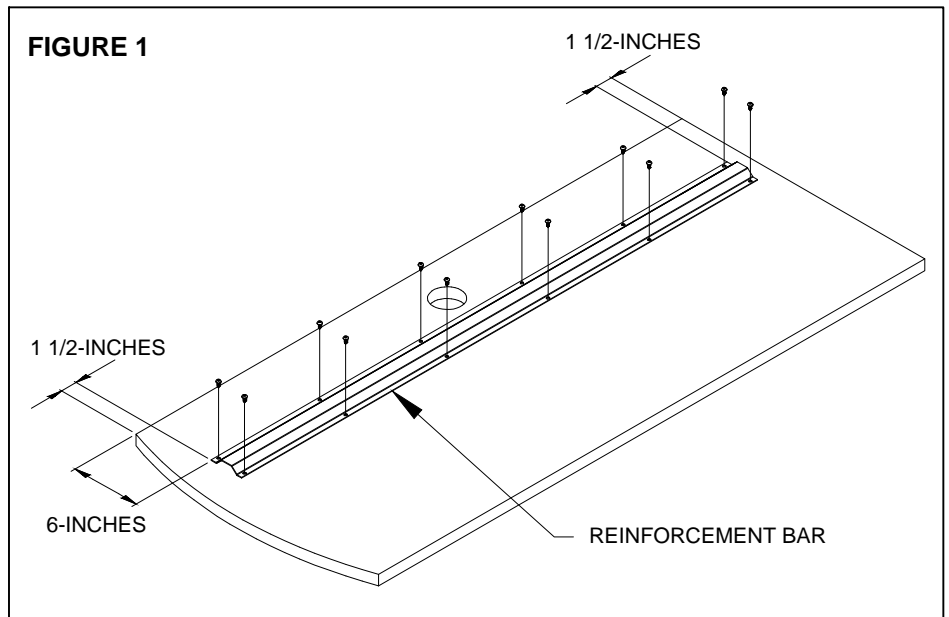

1. Turn the work surface upside down and measure 6 inches from the back and 1 1/2-inches from each side of the work surface; make marks on the surface with a pencil.
2. Position the reinforcement support according to the marks, to be parallel to the back side of the surface.
3. Screw the reinforcement bar on the surface with 11/16-inch oval head screws, then tighten (Figure 1).
4. Turn around the work surface and install it at its proper location (see Worksurface Installation).



NOTE:

- > Reinforcement bars are only installed on surfaces longer than 48-inches (from 54 to 96-inches long) that do not have underdesk pedestals attached to them.

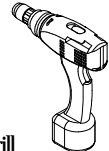
tools & hardware needed

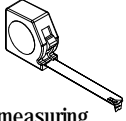
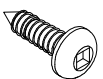
 drill	 #2 Robertson bit	 measuring tape	 11/16" oval head screw
---	---	---	---

open metal gable installation

1. Measure approximately 5 1/2" from the bottom of the panel and position the Bottom Bracket; measure approximately 19 3/4" from the bottom of the panel and position the Top Bracket provided, (Figure 1).
2. Secure the metal gable to the worksurface using four #10 11/16" oval head screws, (Figure 2).

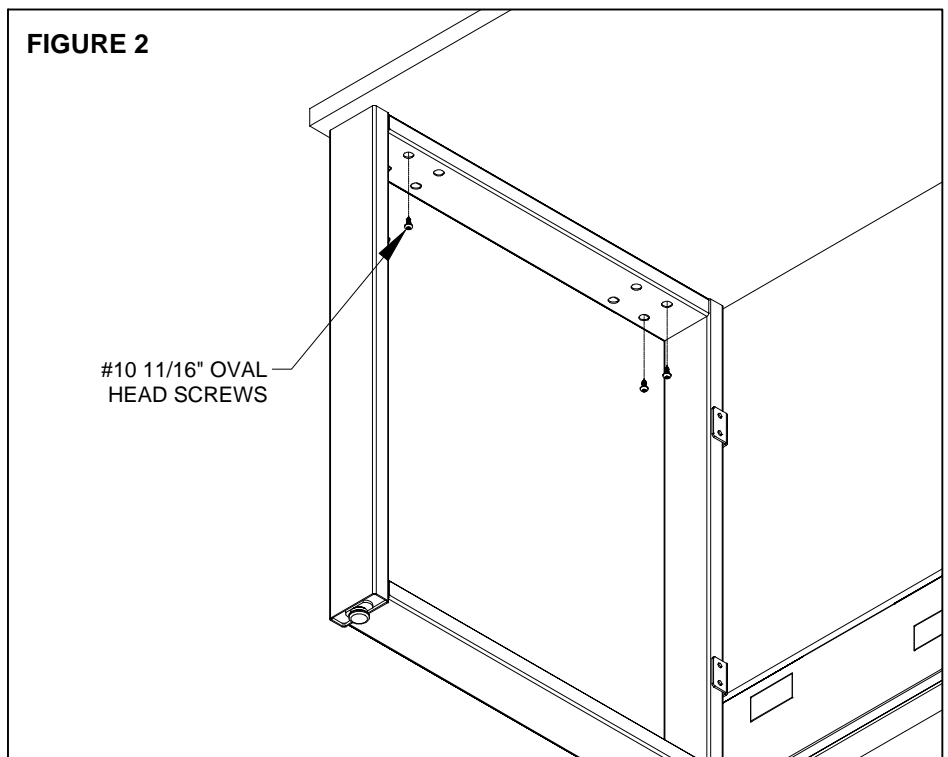
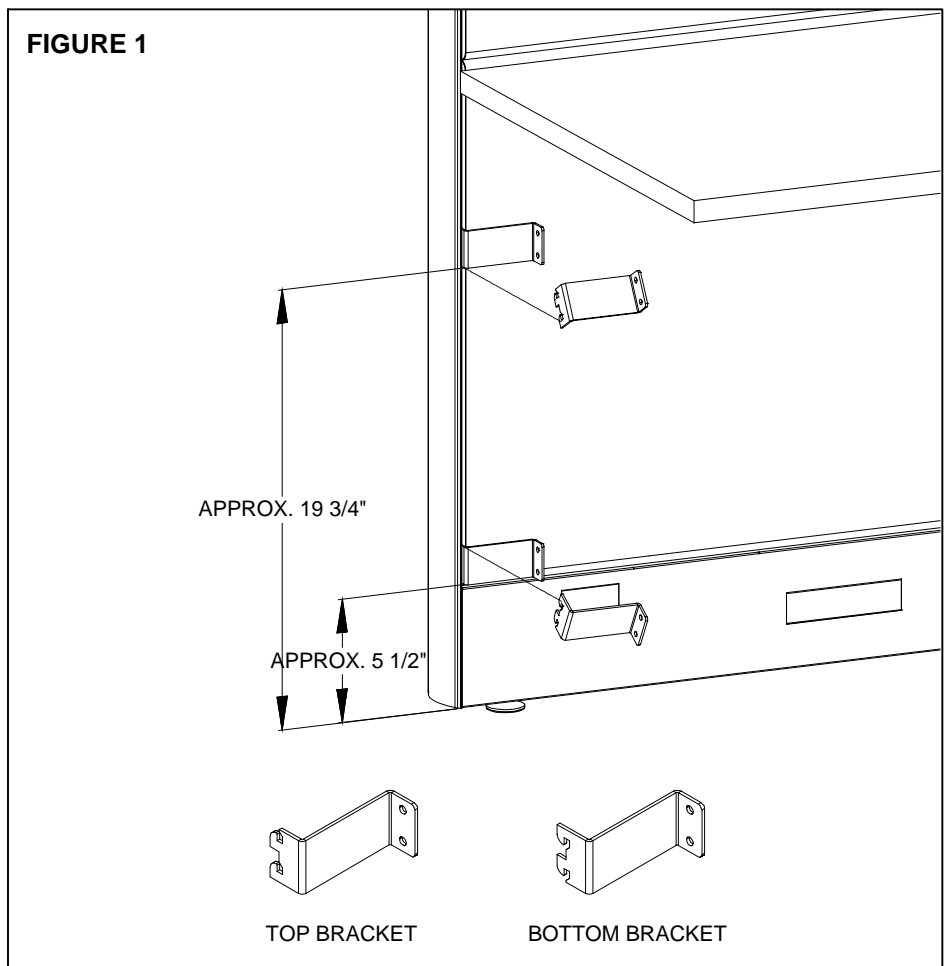



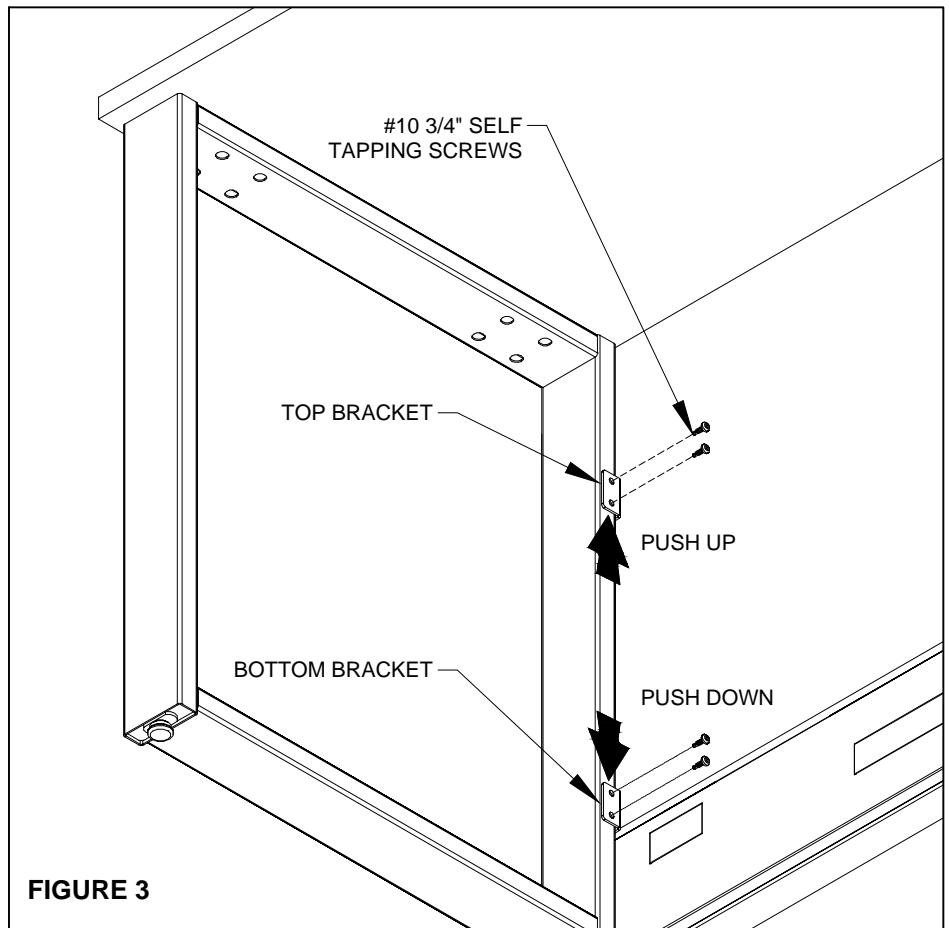

open metal gable installation (cont'd.)

3. Push Down on the Bottom Bracket to engage the lock and secure with two #10 3/4" self tapping screws, (Figure 3).
4. Push-up on the Top Bracket to engage the lock and secure with two #10 3/4" self tapping screws, (Figure 3).
5. Level the worksurface by adjusting the glides on the metal gable.

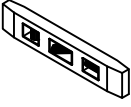
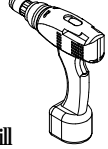

tools & hardware needed

				
torpedo level	drill	#2 robertson long bit	6, #10 11/16" oval head screw	4, #10 3/4" self tap screw

end gable pedestal installation

End gables pedestal are attached to panel frames with end gable brackets (two per end gable) that come in left or right.

1. Measure up to 24-inches in height from the bottom of the panel for the upper gable bracket. The lower gable bracket is to measure from the bottom of the panel up to 8-inches, (Figure 1).
2. Insert the end gable brackets by angling them at 30 degrees; place the gable bracket hook into the slotted frame channel, release it down and the gable brackets will be engaged, (Figure 2).
3. Remove drawers from pedestal by disengaging the safety lock located at the sides of the drawer, (Figure 3).
4. Position the gable pedestal into place; level and adjust glides if necessary.
5. Attach the gable pedestal to the gable brackets on the panel with four, 11/16-inch oval head screws, using #2 Robertson bit, (Figure 4).

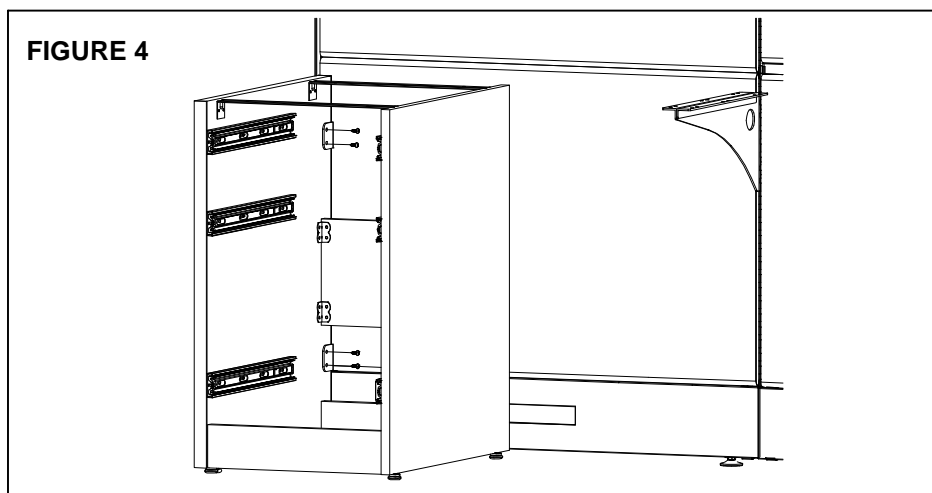
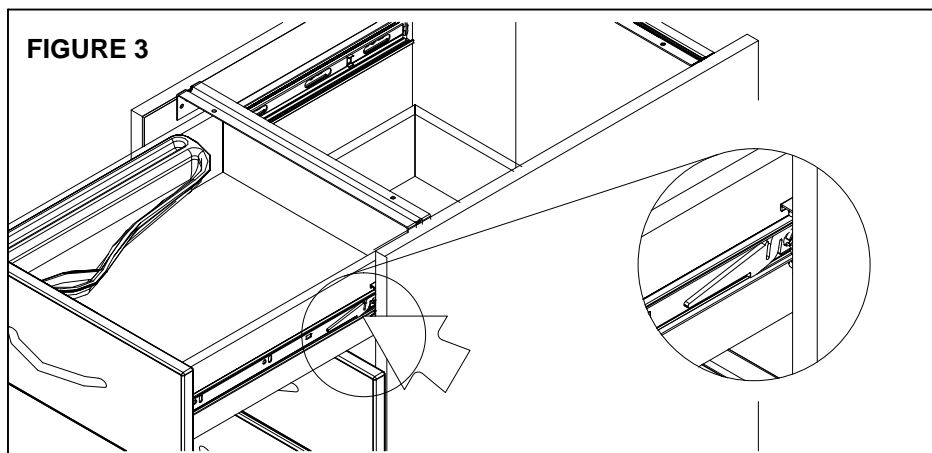
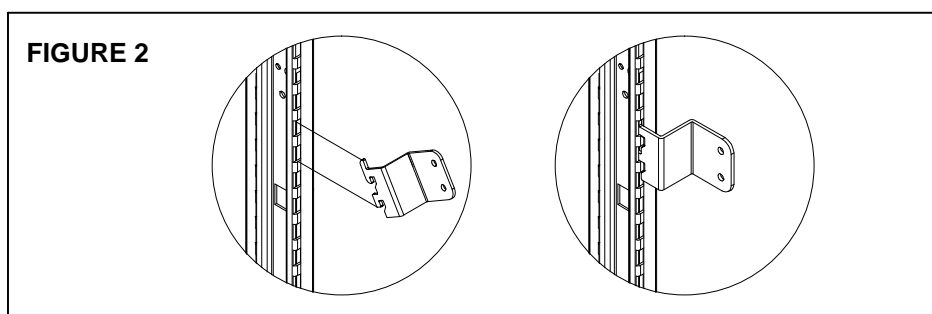
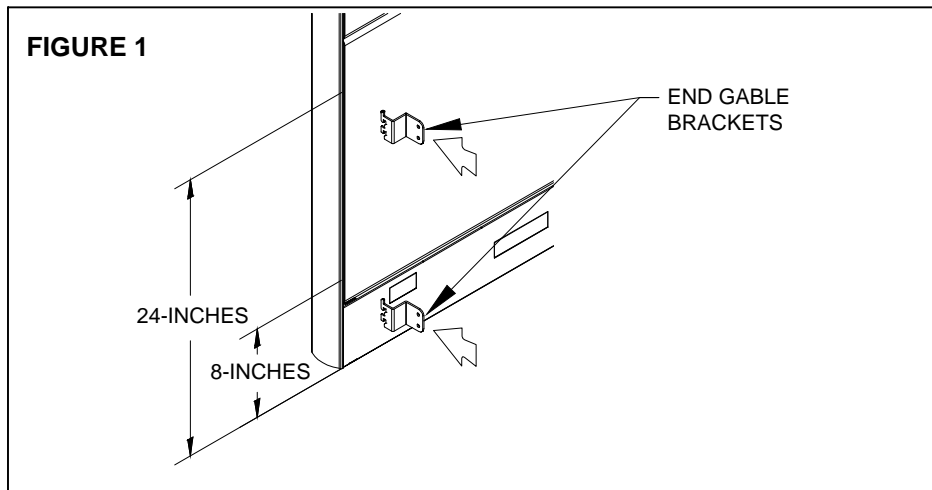

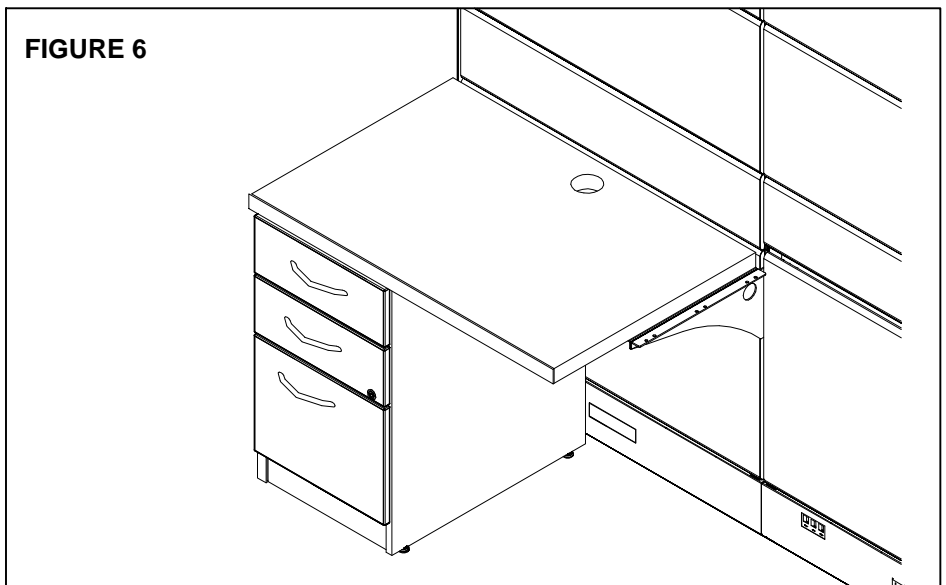
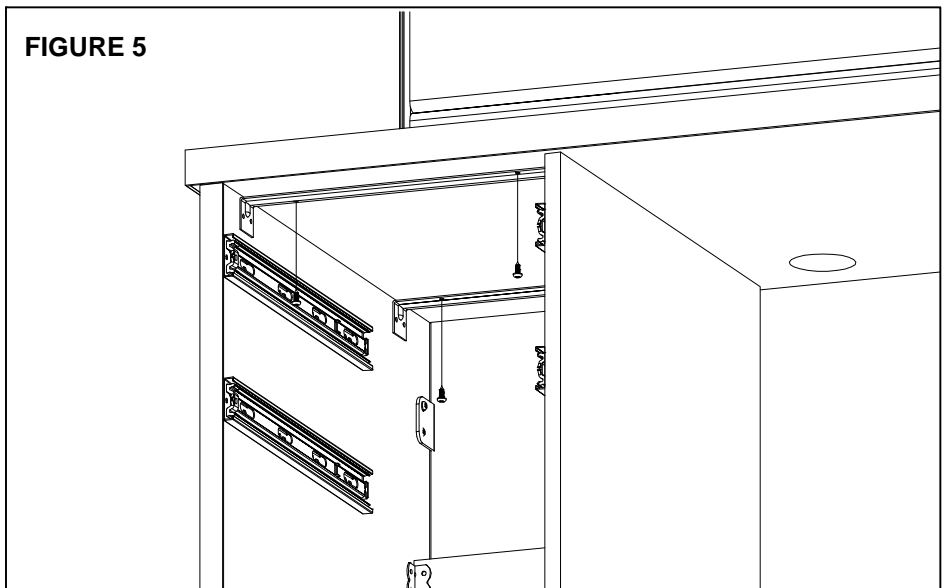

end gable pedestal installation (cont'd)

6. Attach the gable pedestal to the surface with four, 11/16-inch oval head screws, using #2 Robertson bit, (Figure 5).
7. Insert the drawers back into the pedestal, (Figure 6).

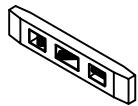
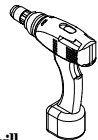

tools & hardware needed

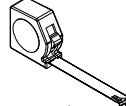
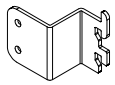
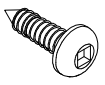
					
torpedo level	drill	#2 Robertson long bit	measuring tape	2, end gable bracket	11/16" oval head screw

metal pedestal to metal filler bracket

1. Remove drawers from the metal pedestal by engaging the release lock located on the sides of the drawer, (Figure 1).
2. Peel the film of the double sided tape attached to the metal filler bracket, (Figure 2).
3. Position the metal filler bracket to gable side of the metal pedestal; and secure with three #10x5/8" self drilling screws, (Figure 2).

*Left-hand 30"D configuration shown.

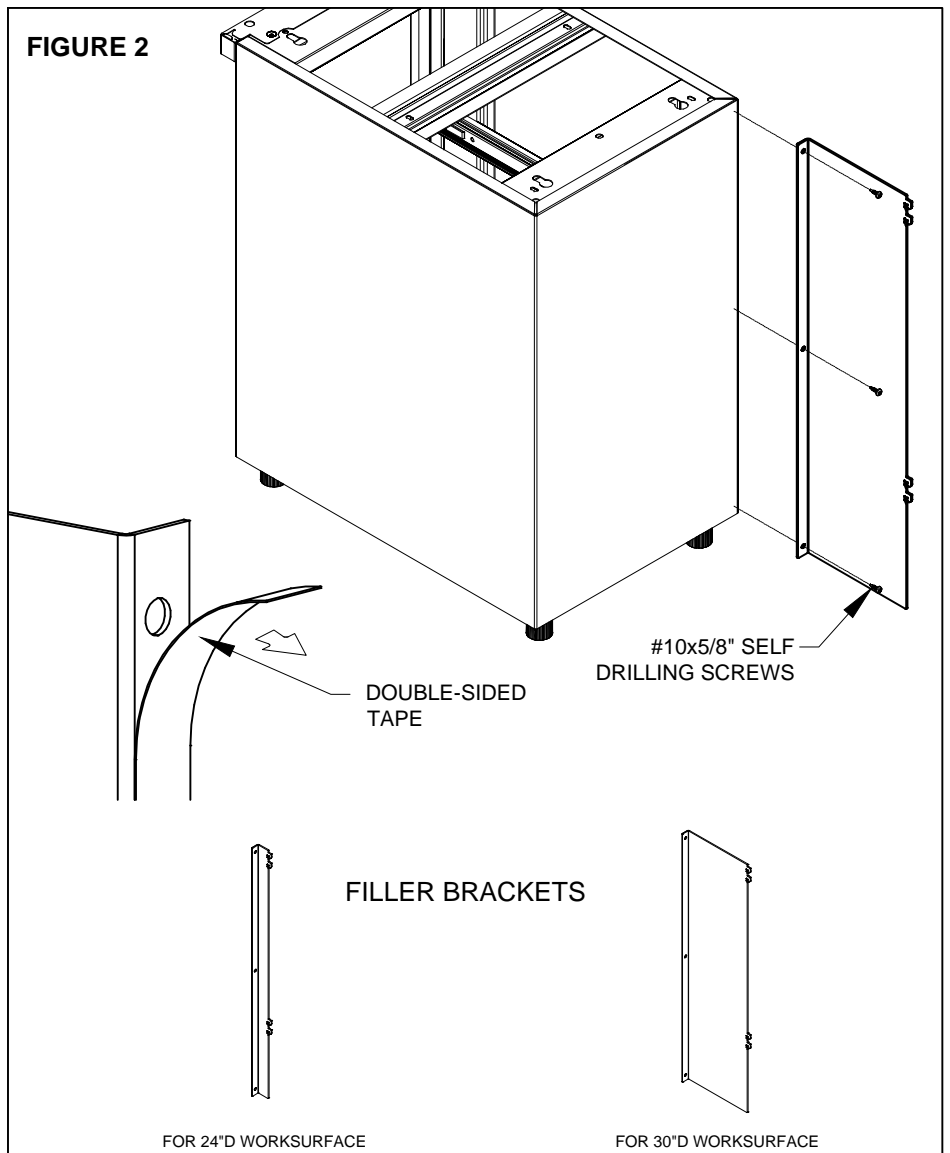
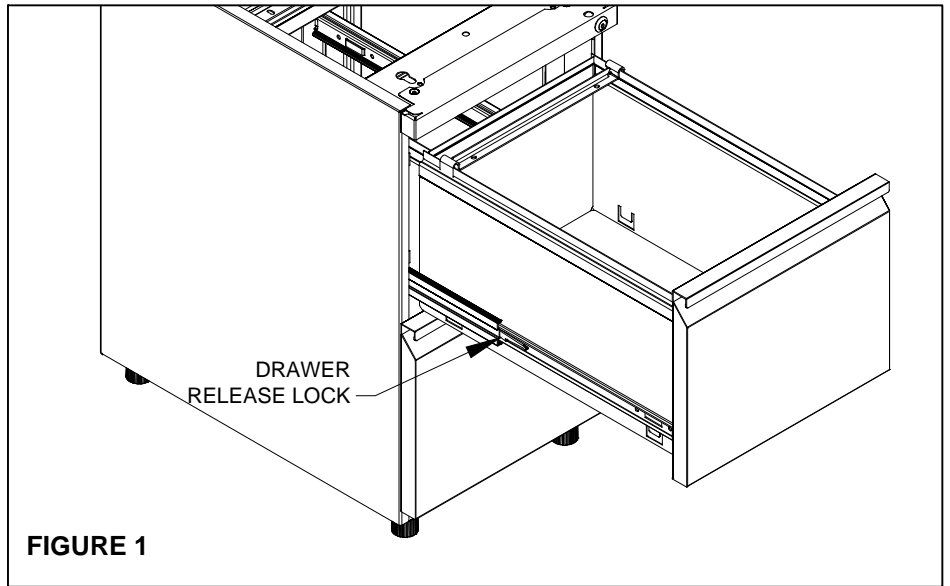



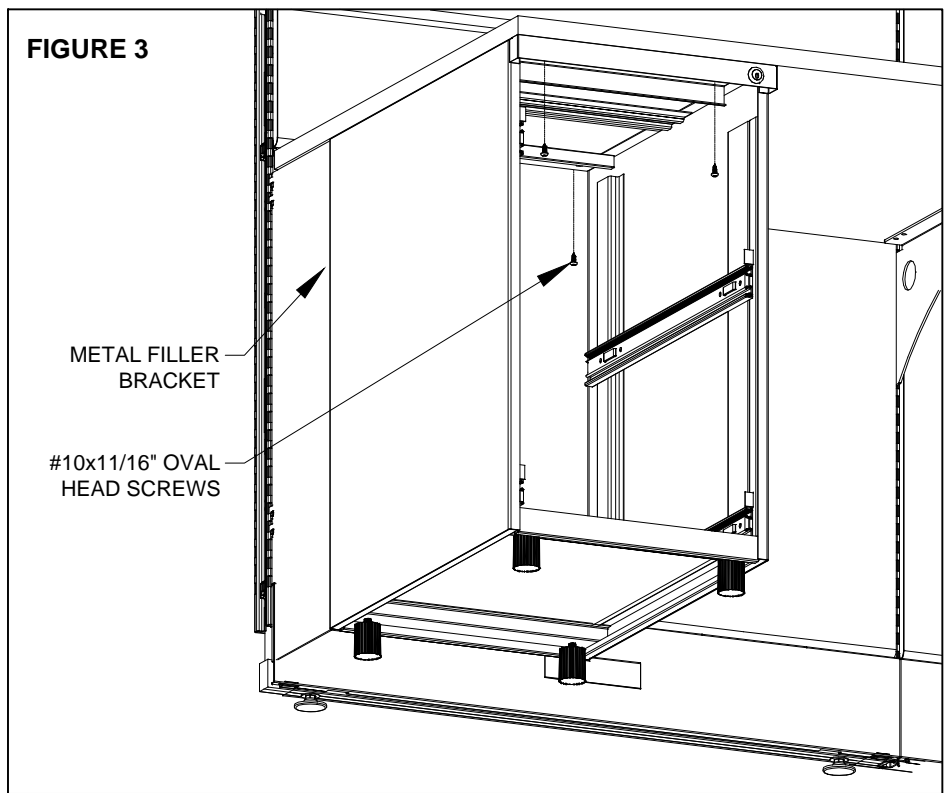

metal pedestal to metal filler bracket (cont'd.)

4. Insert the metal filler bracket to slotted frame channel of the metal pedestal; position the worksurface on the pedestal and secure with four #10x11/16" ovalhead screws, (Figure #3).

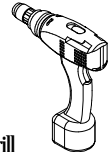

tools & hardware needed

 drill	 #2 robertson long bit	 4, #10x11/16" oval head screw	 3, #10x5/8" self tap screw
---	--	--	---

overhead storage installation

1. Angle the flipper cabinet or overhead shelf at 30 degree angle, (Figure 1).
2. Place the upper hooks at their desired location into the slotted frame channel, release them down and the flipper cabinet or overhead shelf will be engaged, (Figure 2).

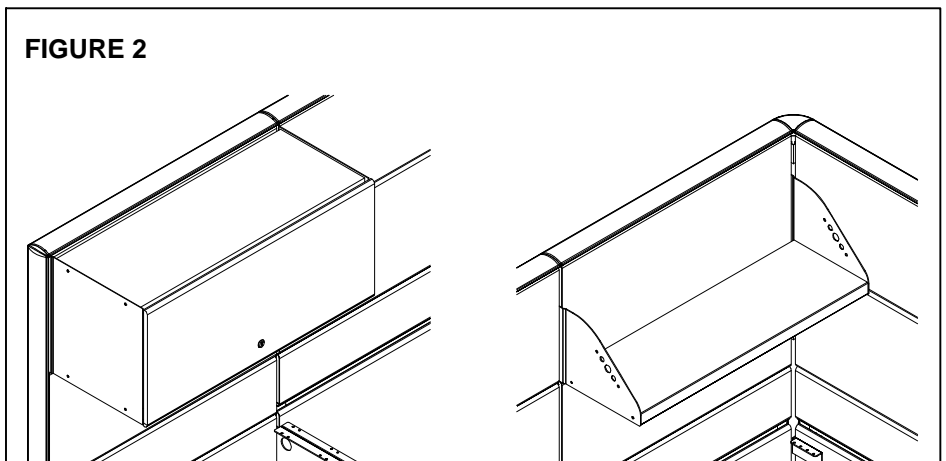
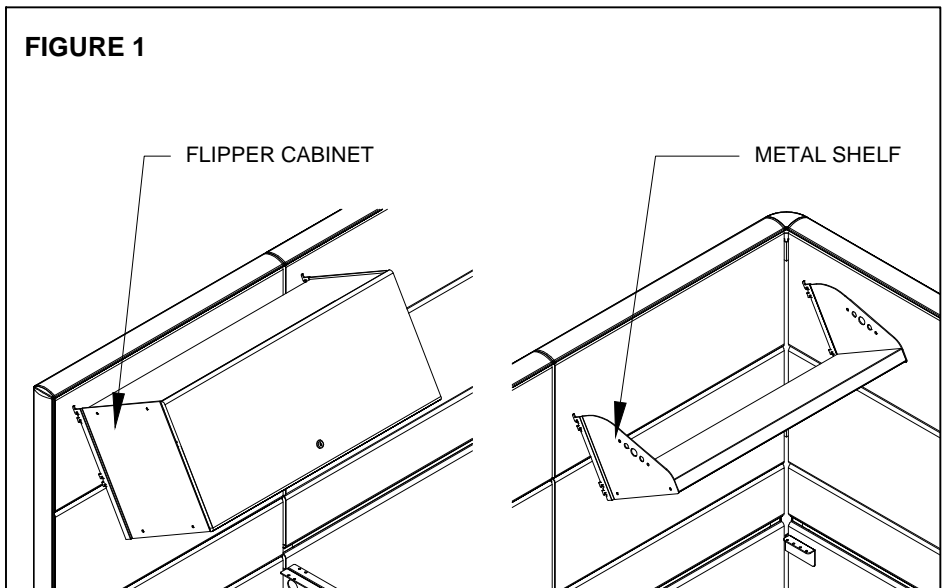

suspended overhead storage installation

1. Angle the suspended flipper cabinet brackets at 30 degree angle and insert the upper hooks into the slotted frame channel, release them down and the bracket will be engaged, (Figure 1).
2. Place the flipper cabinet on the brackets and secure with four 1/4" #20; 1/2-inch pan head machine screws, (Figure 2).

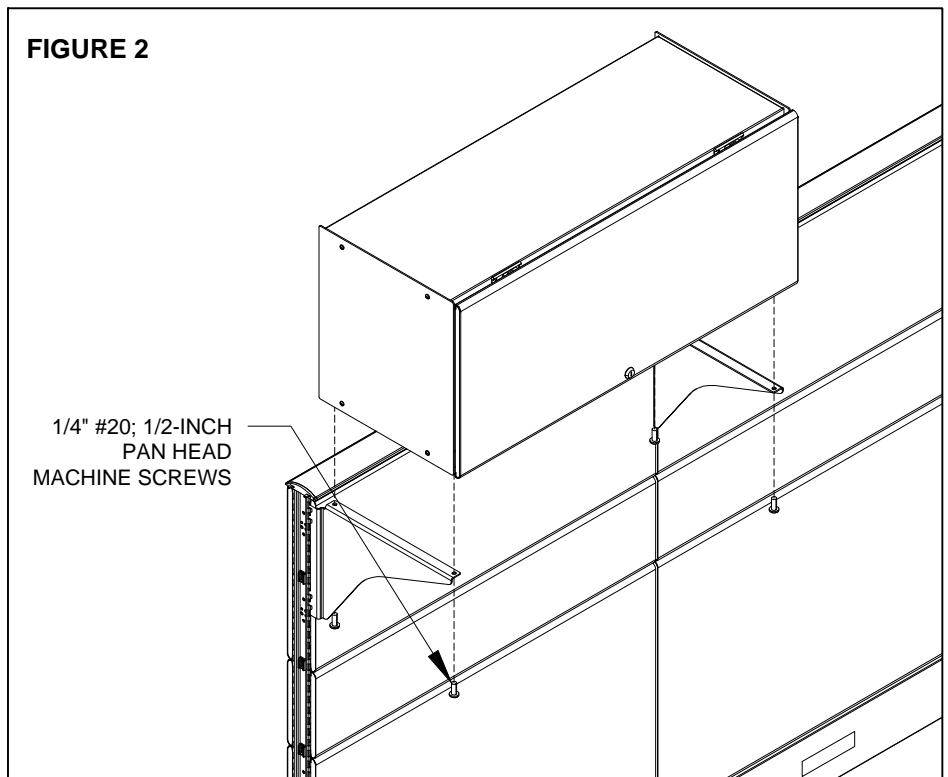
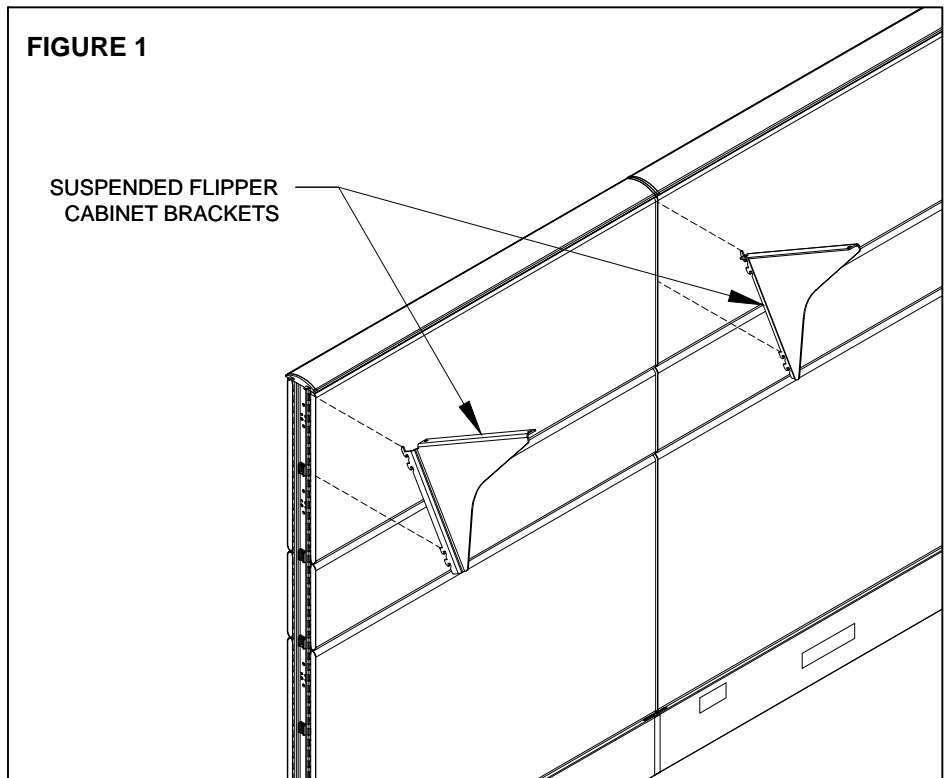

tools & hardware needed

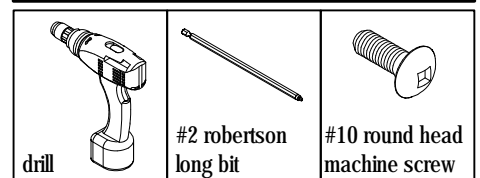

cubby storage installation

1. Angle the cubby storage at 30 degree angle, (Figure 1).
2. Place the upper hooks at their desired location into the slotted frame channel, release the down and the cubby storage will be engaged, (Figure 2).

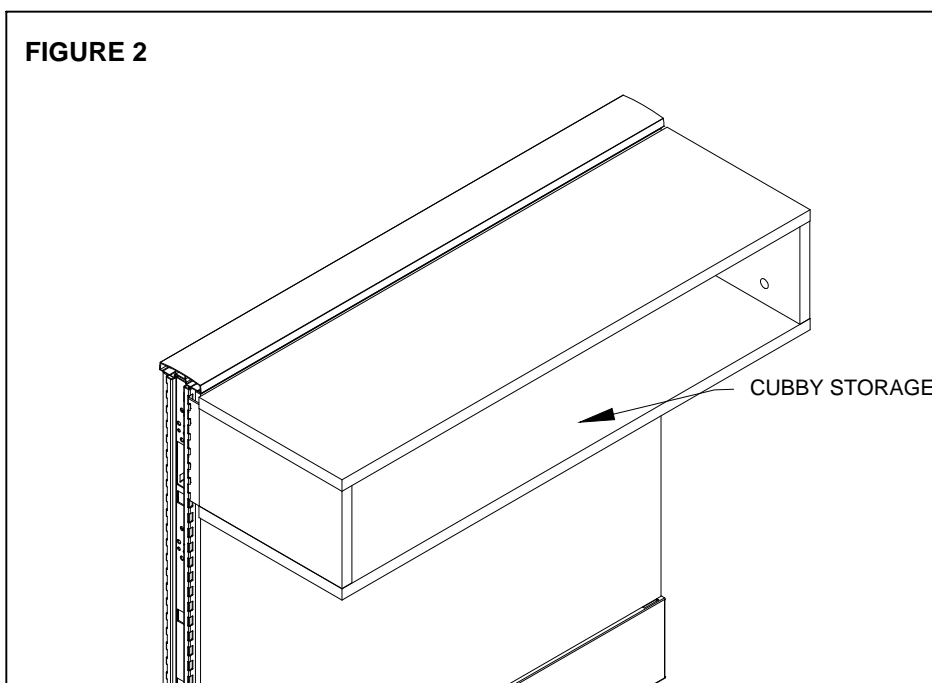
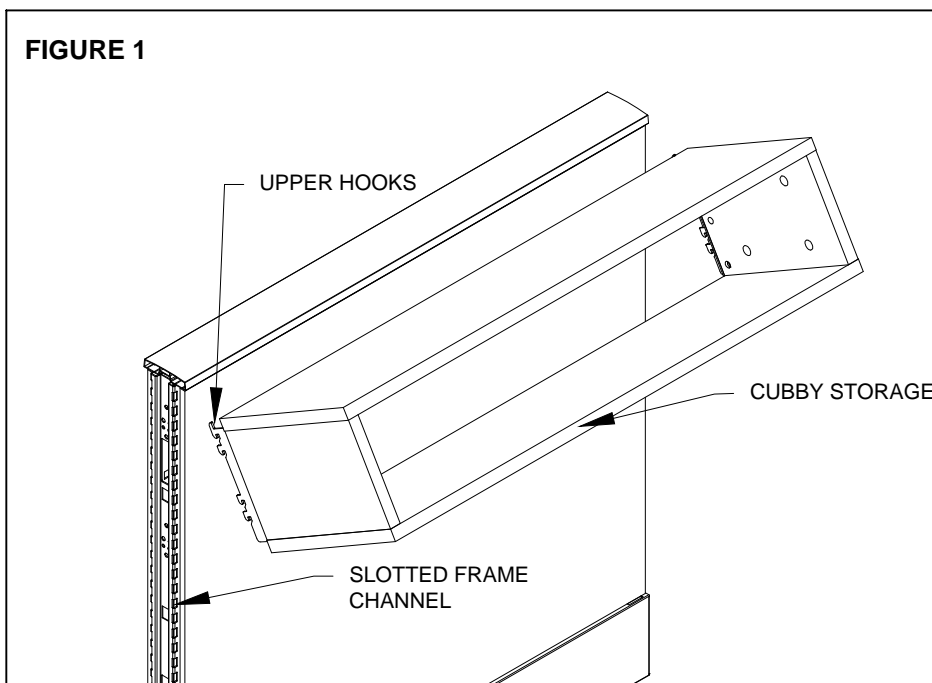

top panel shared shelf installation

1. Verify the location of the top panel shared shelf and remove the filler cap, top trims and clips from the panel, (Figure 1).
2. Position the shared shelf on the center of the panel, (Figure 2).

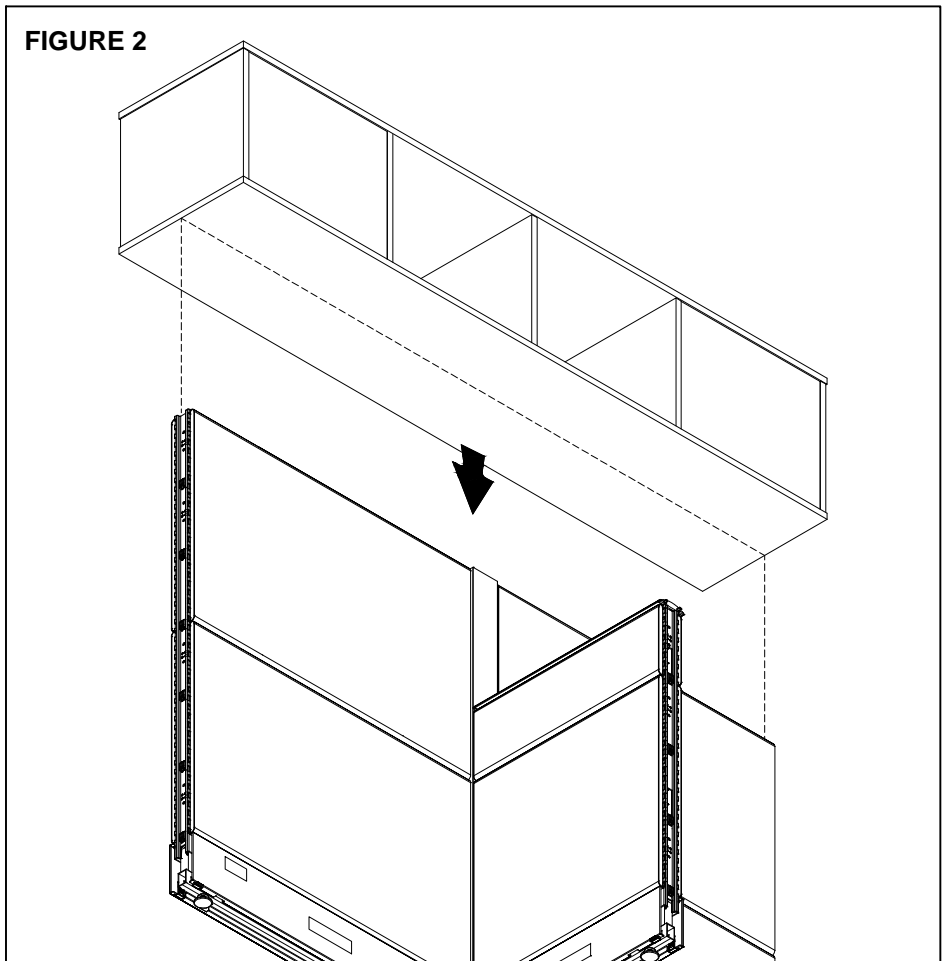
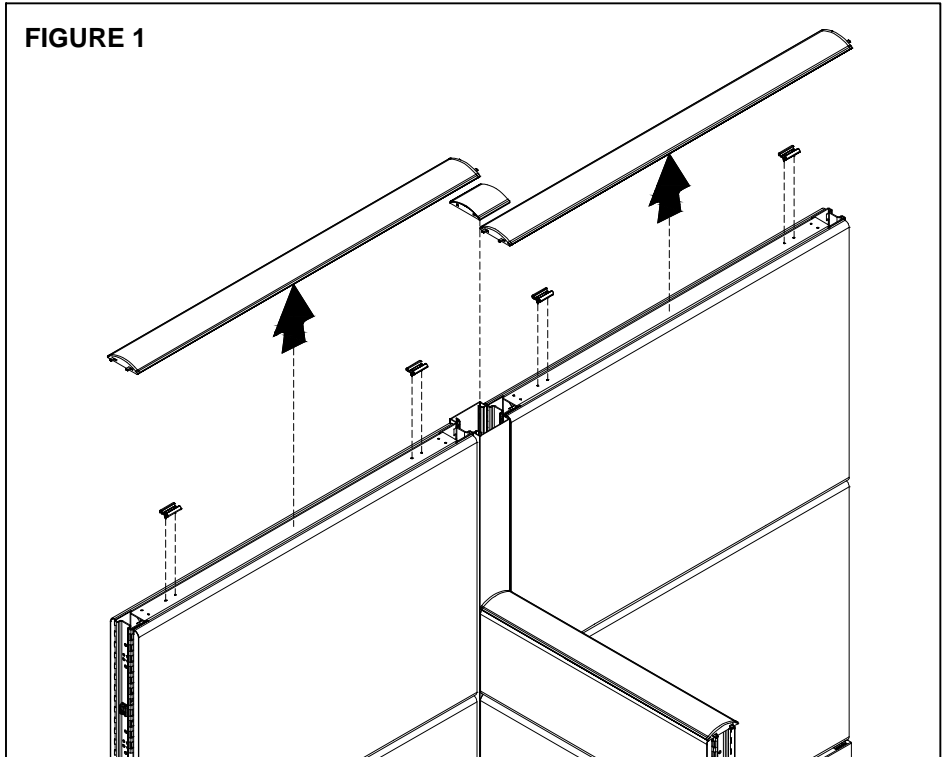

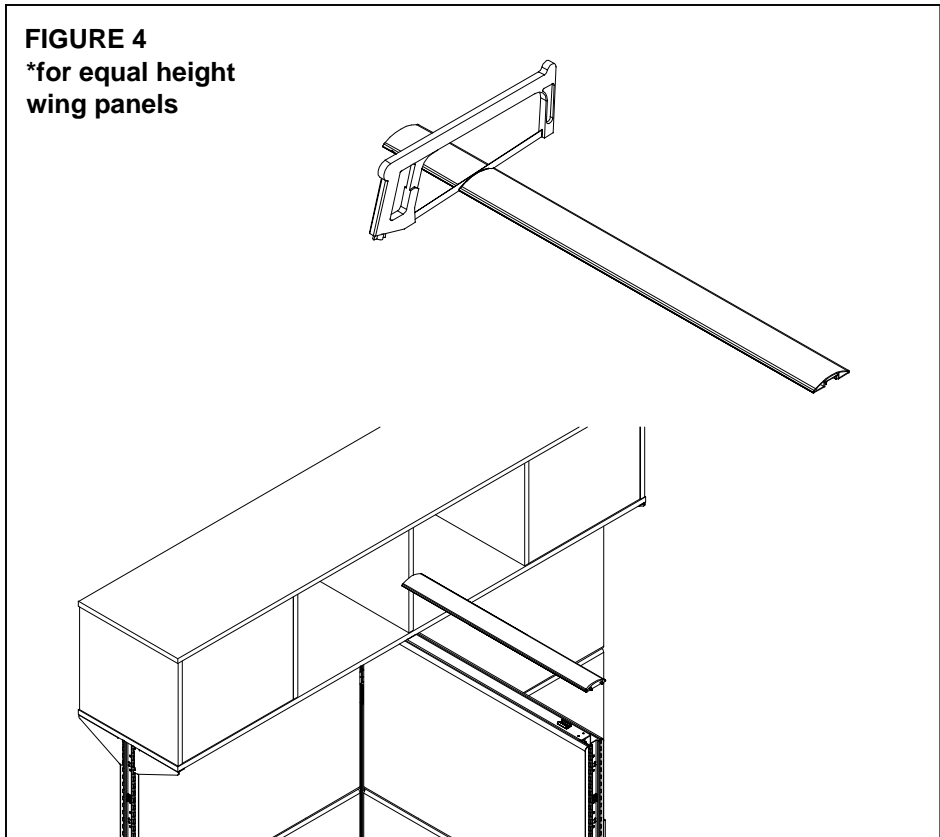
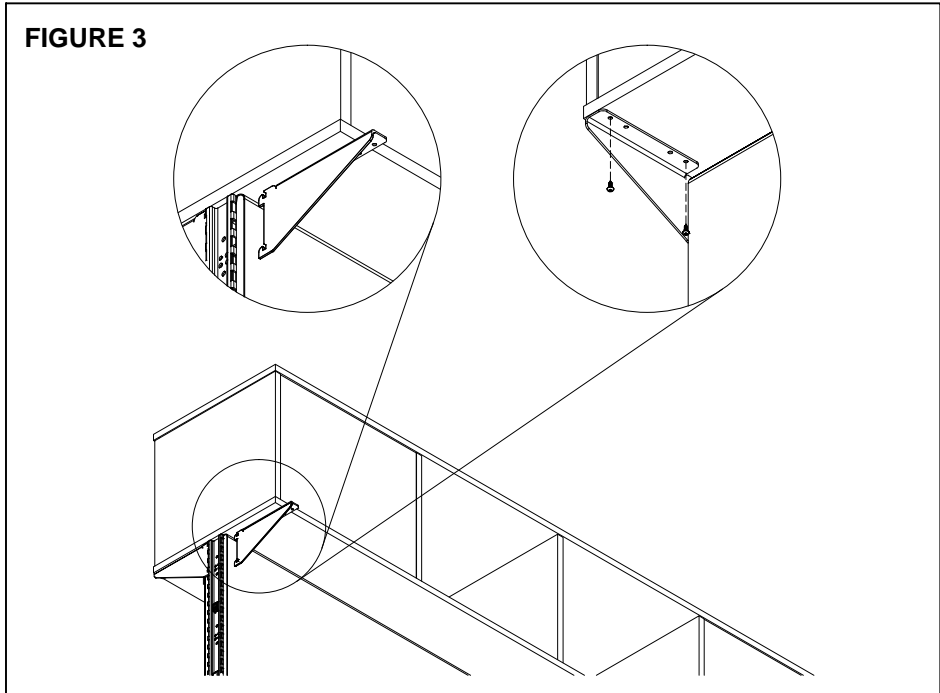

top panel shared shelf installaion(cont'd.)

3. Insert the shelf bracket to the top most slot in the panel frame; push the bracket up to engage the lock and secure with two 11/16-inch ovalhead screws using #2 Robertson bit, (Figure 3).
4. For panel configurations with wing panels of equal heights, cut the top trim to size using a hacksaw, (Figure 4).

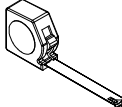
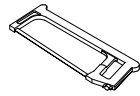
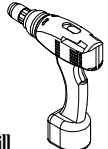

tools & hardware needed

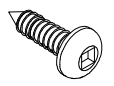
 measuring tape	 hacksaw	 drill	 #2 robertson long bit	 6, #10 11/16" oval head screw
---	---	--	--	--

accessory bar installation

Accessory Bar over Tiles

1. Angle the accessory bar at 30 degree; place the upper hooks at their desired location into the slotted frame channel, release them down and the accessory bar will be engaged, (Figure 1).

FIGURE 1

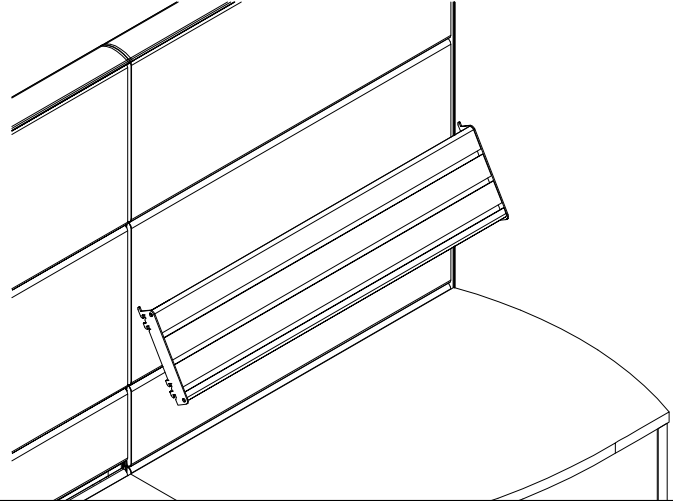
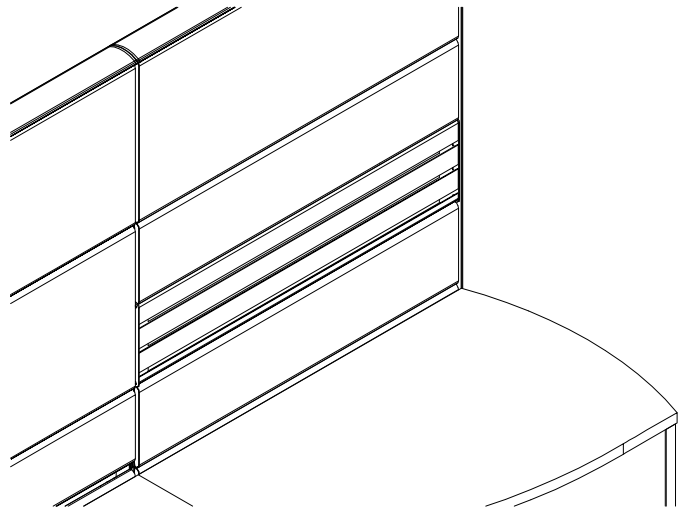

FIGURE 2



accessory bar installation (cont'd)

Accessory Bar Tile

1. Remove the tile above the location of the accessory bar tile, then angle the accessory bar tile at 30 degrees, (Figure 1).
2. Place the upper hooks at their desired location into the slotted frame channel, release them down and the accessory bar tile will be engaged, (Figure 2).
3. Re-install the tile previously removed, (Figure 3).

FIGURE 1

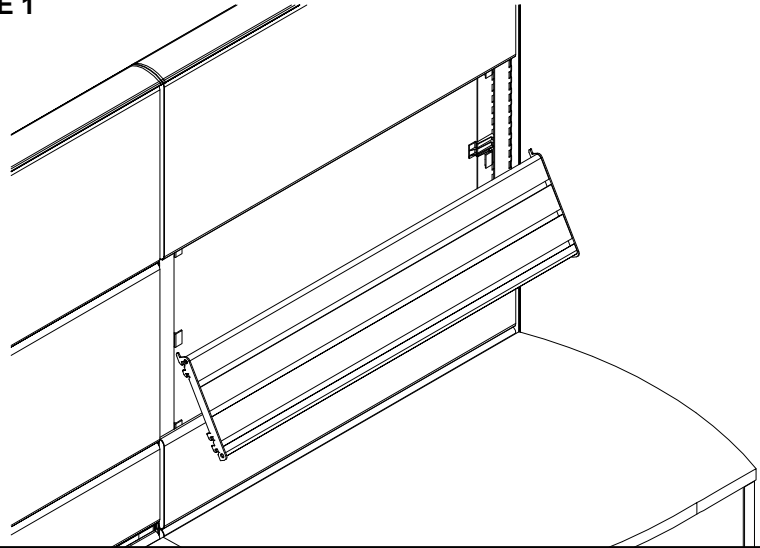

FIGURE 2

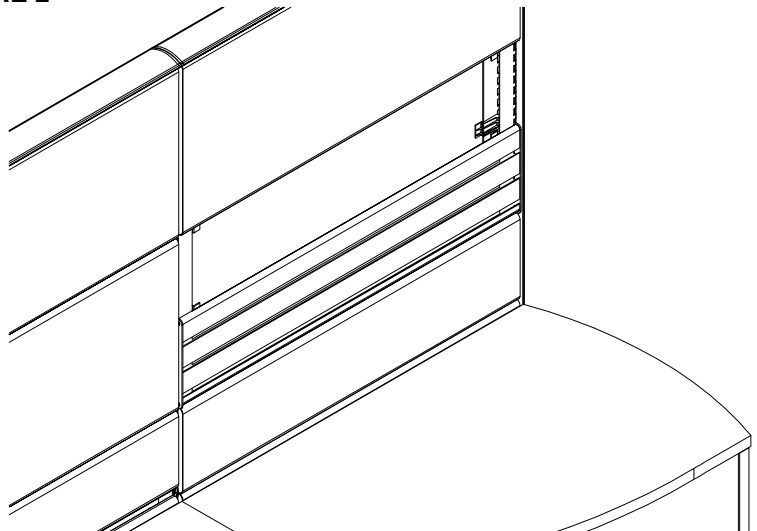
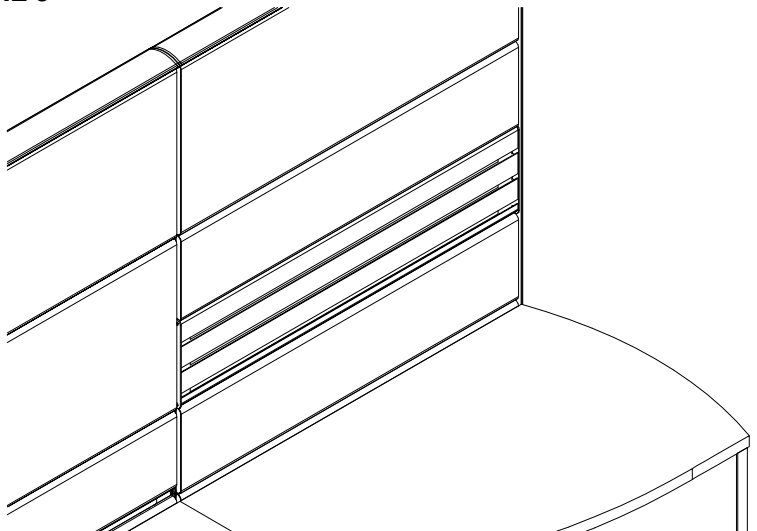

FIGURE 3



accessory organizer installation

1. Angle the paper tray at 30 degrees; place the hooks at their desired location into the accessory bar channels, release them down and the paper tray will be engaged, (Figure 1).

FIGURE 1

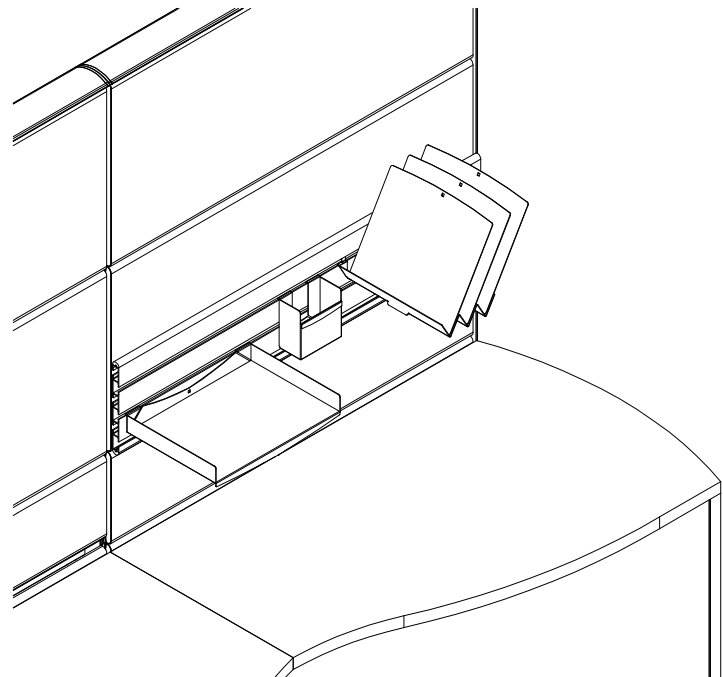
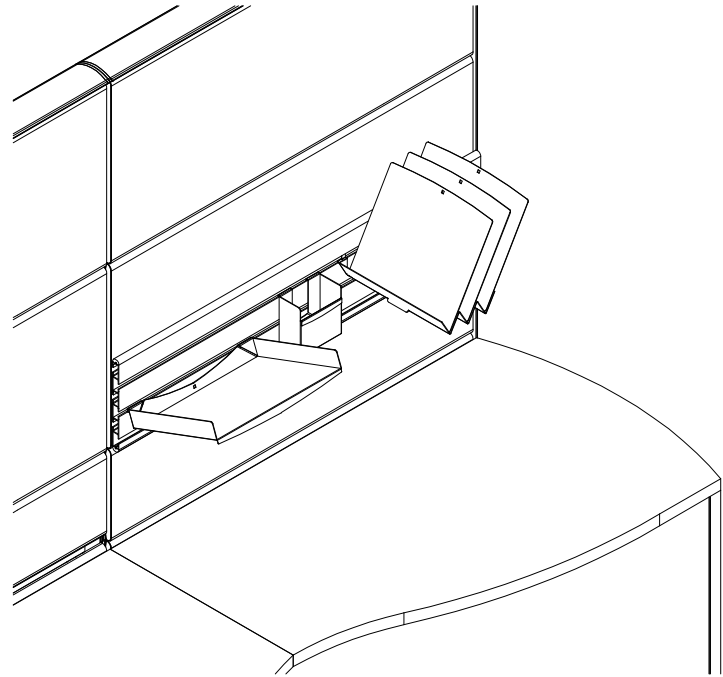

accessory organizer installation (cont'd)

2. Proceed in the same way to install the accessories listed in Figure 2.

FIGURE 2

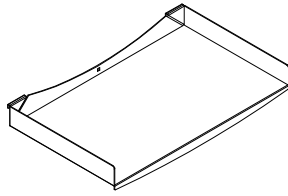

Paper Tray,
Legal

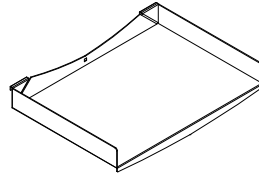

Paper Tray,
Letter

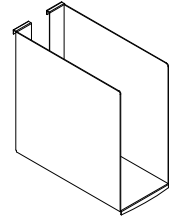

Binder Bin

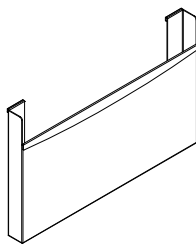

Paper
Holder, Legal

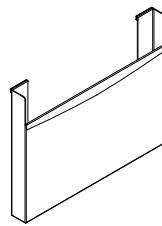

Paper
Holder,
Letter

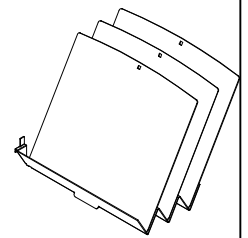

Paper
Sorter

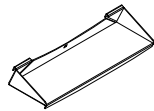

Pen Tray

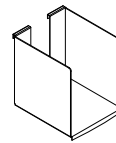

Multi-media
Holder

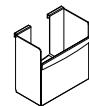

Pen Holder

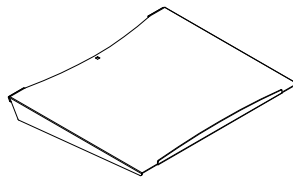

Phone Tray
10x9

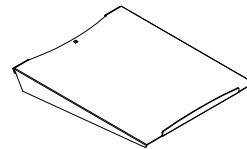



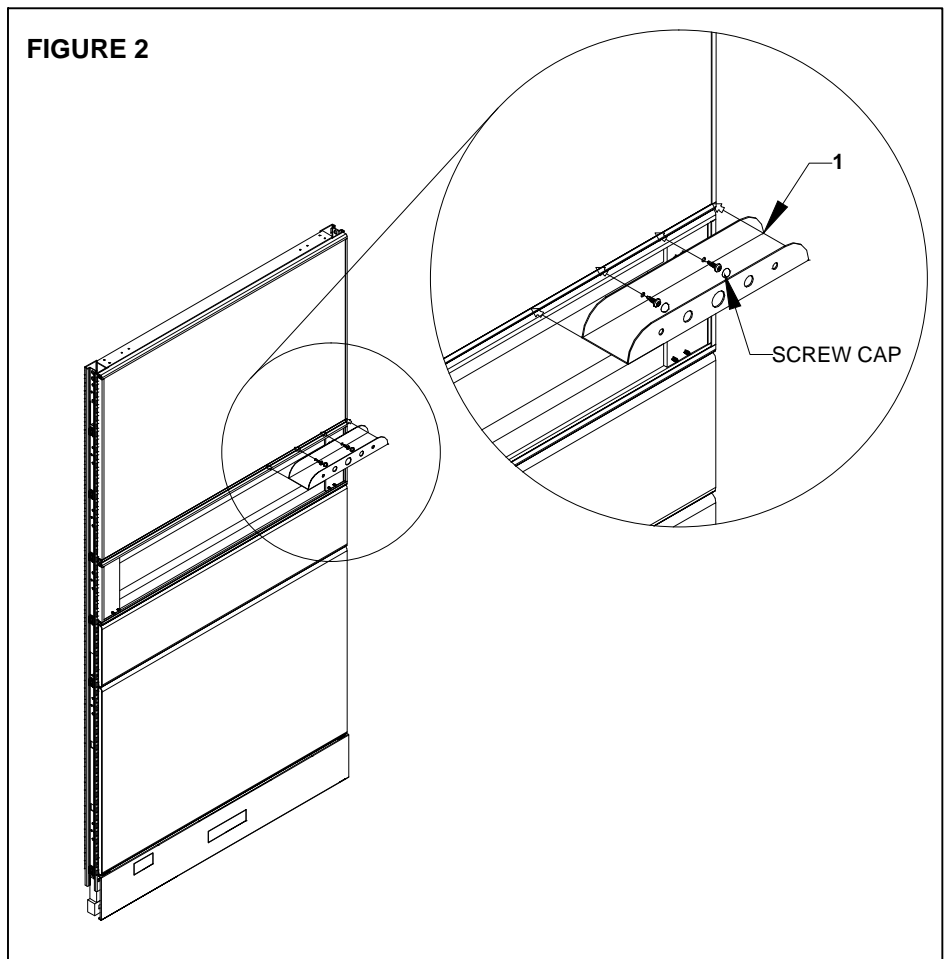
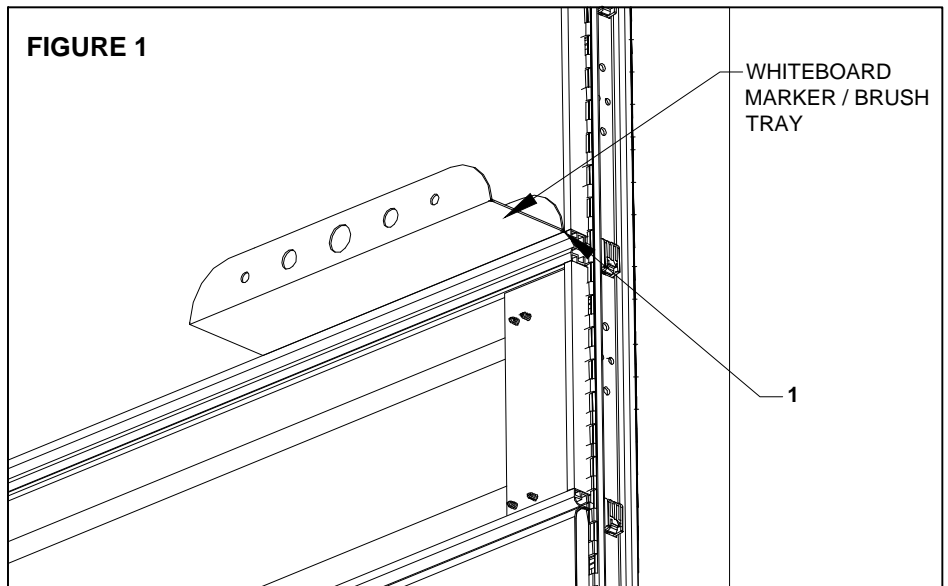

Phone Tray
10x13

whiteboard marker / brush tray installation

1. Place the tray against the whiteboard tile. Make sure the bottom edge corner of the tray, see point no. 1, is at the corner of the metal frame of the whiteboard tile. Make sure the tray sits on the bottom of the metal frame of the whiteboard tile, (Figure 1).
2. Using a #2 Robertson long bit, insert the #10, 1/2-inch self tap screw into the holes of the tray; Place the screw caps, (Figure 2).

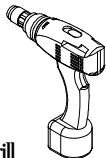

tools & hardware needed

 drill	 #2 Robertson long bit	 2, #10 1/2" self tap screw	 2, screw cap
---	--	---	---

top mounted screen installation

1. Verify the type of top trims the panels have.

Curved top trims ensure that the rubber mushroom bumper are in place, (Figure 1).

Straight top trims ensure that the rubber mushroom bumper are removed, (Figure 2).

2. Position the top screen clamp gaskets on the screen centered over the bottom holes.

3. Snap the top trim mounted screen clamps to the top trim mounted privacy screen, (Figure 3).

4. Snap the top trim mounted screen assembly on the top trim at the specified location, (Figure 4).

FIGURE 1

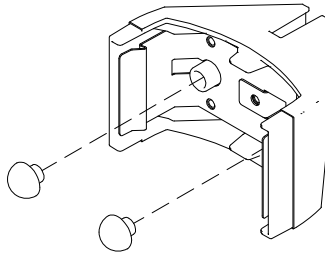

CURVED TOP TRIMS

FIGURE 2

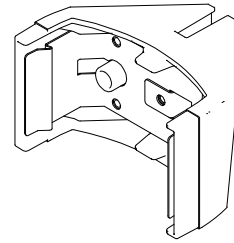

STRAIGHT TOP TRIMS

FIGURE 3

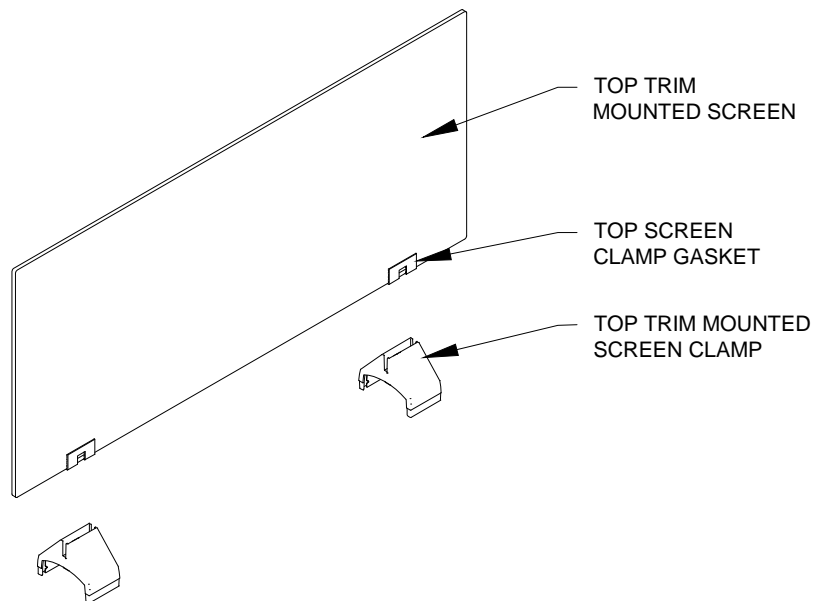

NOTES:

- > The top trim mounted screen is off-module between panels, and can be specified the same width as the panel it is to be mounted to, or less.
- > The top trim mounted privacy screen does not provide acoustical privacy.
- > The top trim mounted privacy screen is not load bearing.

FIGURE 4

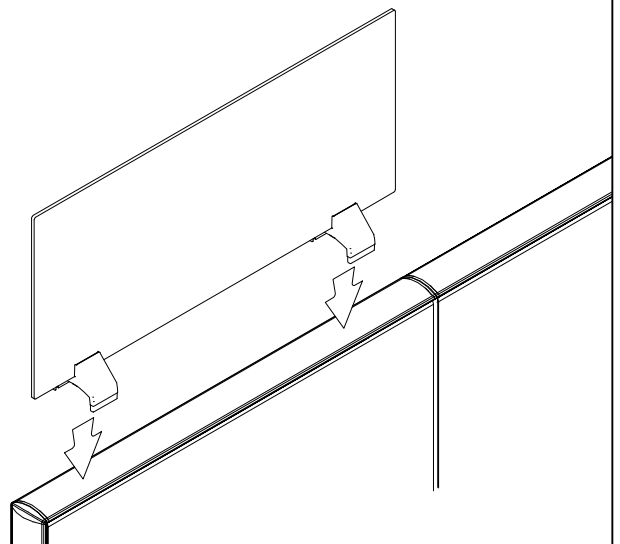

panel top mounted glass/acrylic screen

1. Check the panel top mounted glass /acrylic Frameless Glass/Acrylic Extrusion if there is a X-mas tree on both ends before placing it on top of the top trim, (Figure 1).
2. Align the holes of Frameless Glass/Acrylic Extrusion into the pre-drilled holes of the top trim.
3. Securely fasten Frameless Glass/Acrylic Extrusion into the pre-drilled holes of top trim with #8 X 2", Flat Head Self Drilling Screws, (Figure 2).
4. Insert the glass/acrylic with plastic gasket into the base extrusion, (Figure 3).

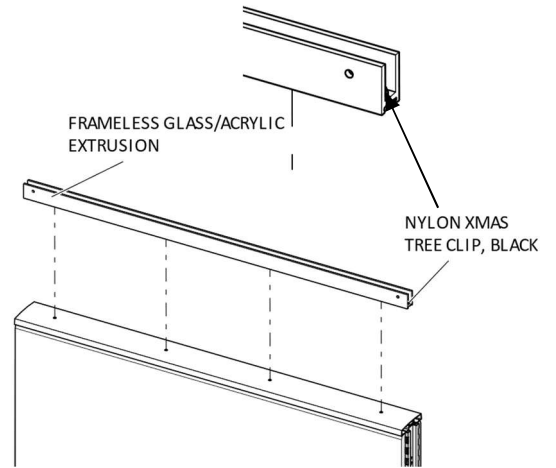
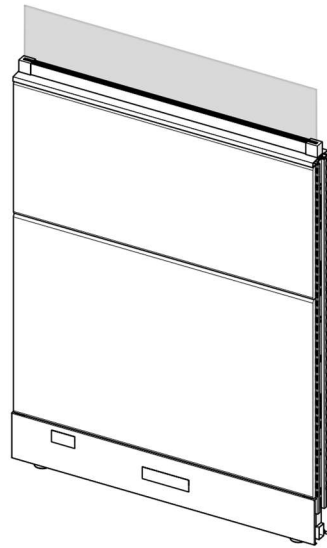

FIGURE 1

Continued on the next page >>

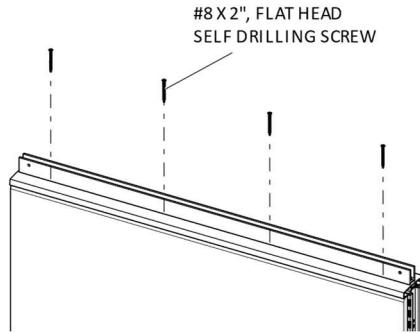

FIGURE 2

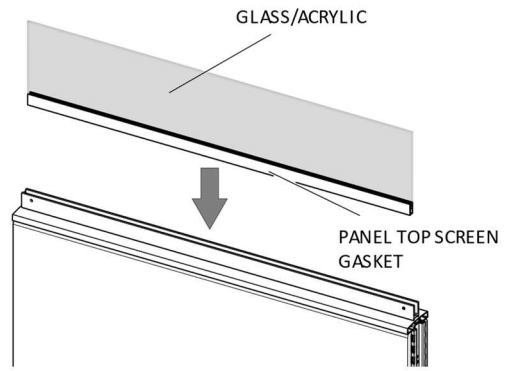
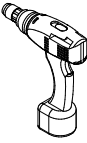



FIGURE 3

tools & hardware needed

				
Drill	Robertson # 2 Bit	#8 X 2", Flat Head Screw (4X)		

panel top mounted glass/acrylic screen

5. Align and secure the glass/acrylic by inserting 1/4-20 X 1/4" Socket Set Screw through each of the holes on the side of the Frameless Glass/Acrylic Extrusion using allen key driver, (Figure 4).
6. Tighten gently each side until the glass/acrylic is centered and secured.
Note: Do not overtighten. Check the base extrusion if it is straight. Overtightening set screws will bend the Frameless Glass/Acrylic Extrusion outward and end caps will not fit.
7. Insert the end cap on both ends of the Frameless Glass/Acrylic Extrusion then push it down to secure, (Figure 5).

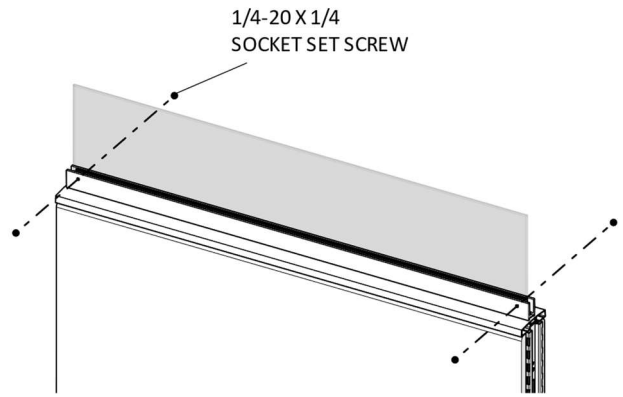

FIGURE 4

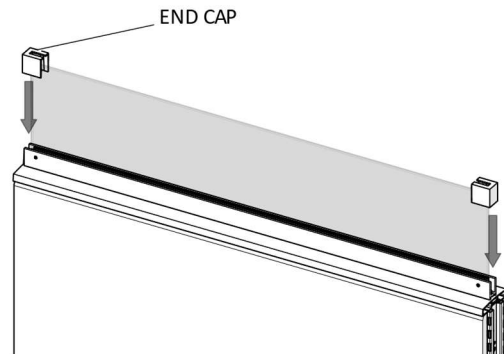

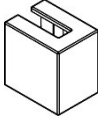

FIGURE 5

tools & hardware needed

	8540-1170 	8400-0144 		
Allen Key	1/4 -20 X 1/4 SS Screw (4X)	End Cap (2X)		

panel top mounted glass/acrylic screen – double span

1. Check the panel top mounted glass /acrylic Frameless Glass/Acrylic Extrusion if there is a X-mas tree on both ends before placing it on top of the top trim, (Figure 1).
2. Align the holes of Frameless Glass/Acrylic Extrusion into the pre-drilled holes of the top trim.

Continued on the next page >>

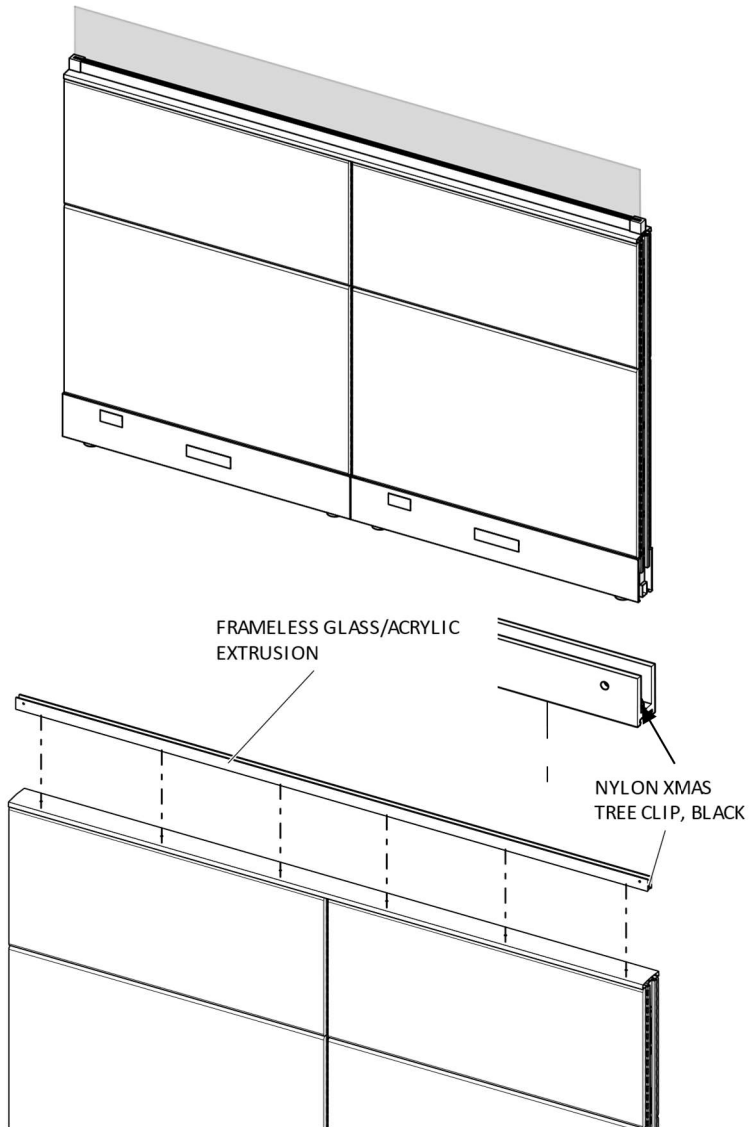

FIGURE 1

tools & hardware needed

panel top mounted glass/acrylic screen – double span

3. Securely fasten Frameless Glass/Acrylic Extrusion into the pre-drilled holes of top trim with #8 X 2", Flat Head Self Drilling Screws, (Figure 2).
4. Insert the glass/acrylic with plastic gasket into the Frameless Glass/Acrylic Extrusion, (Figure 3).

Continued on the next page >>

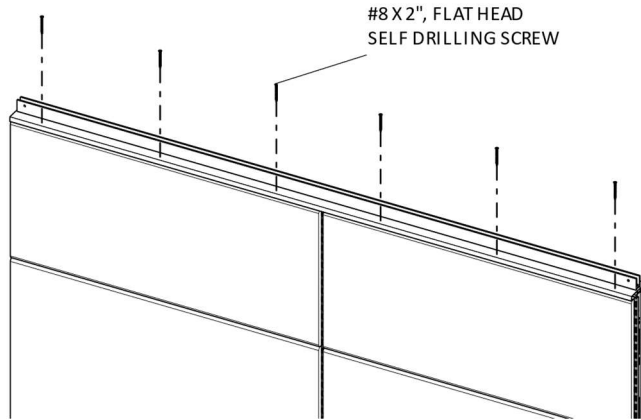

FIGURE 2

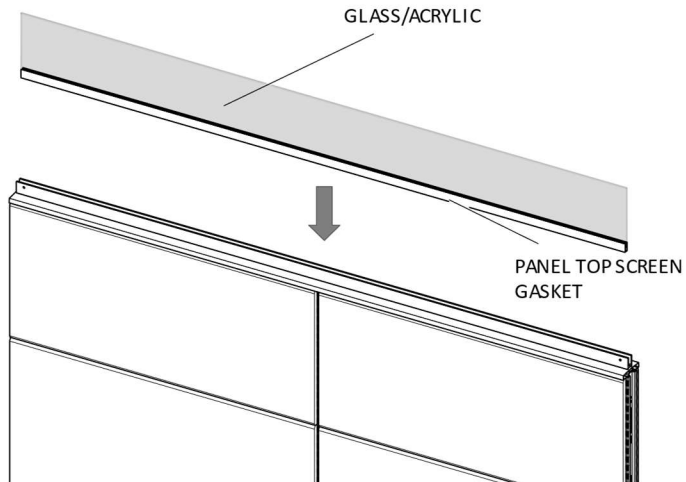
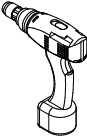
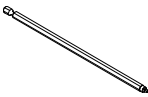



FIGURE 3

tools & hardware needed

		8540-1217 		
Drill	Robertson # 2 Bit	#8 X 2", Flat Head Screw (6X)		

panel top mounted glass/acrylic screen – double span

5. Align and secure the glass/acrylic by inserting 1/4-20 X 1/4" Socket Set Screw through each of the holes on the side of the Frameless Glass/Acrylic Extrusion using Allen Key driver, (Figure 4).
6. Tighten gently each side until the glass/acrylic is centered and secured.
Note: Do not overtighten. Check the base extrusion if it is straight. Overtightening set screws will bend the Frameless Glass/Acrylic Extrusion outward and end caps will not fit.
7. Insert the end cap on both ends of the Frameless Glass/Acrylic Extrusion then push it down to secure, (Figure 5).

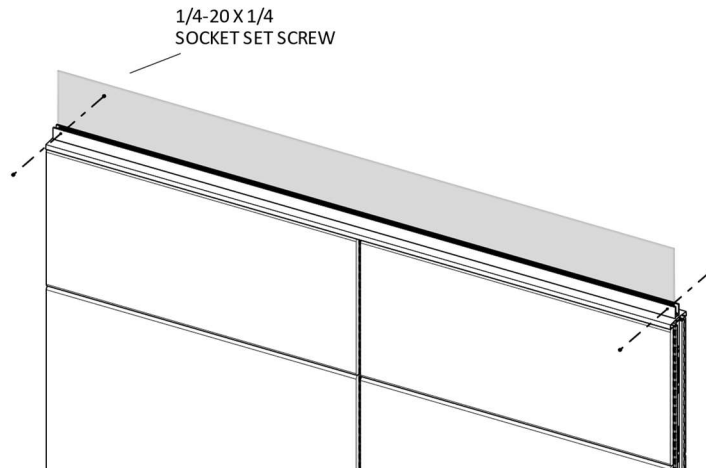

FIGURE 4

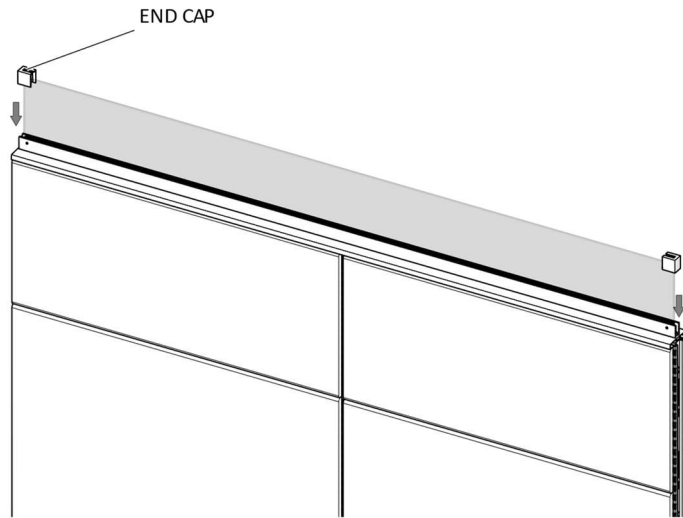

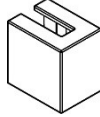
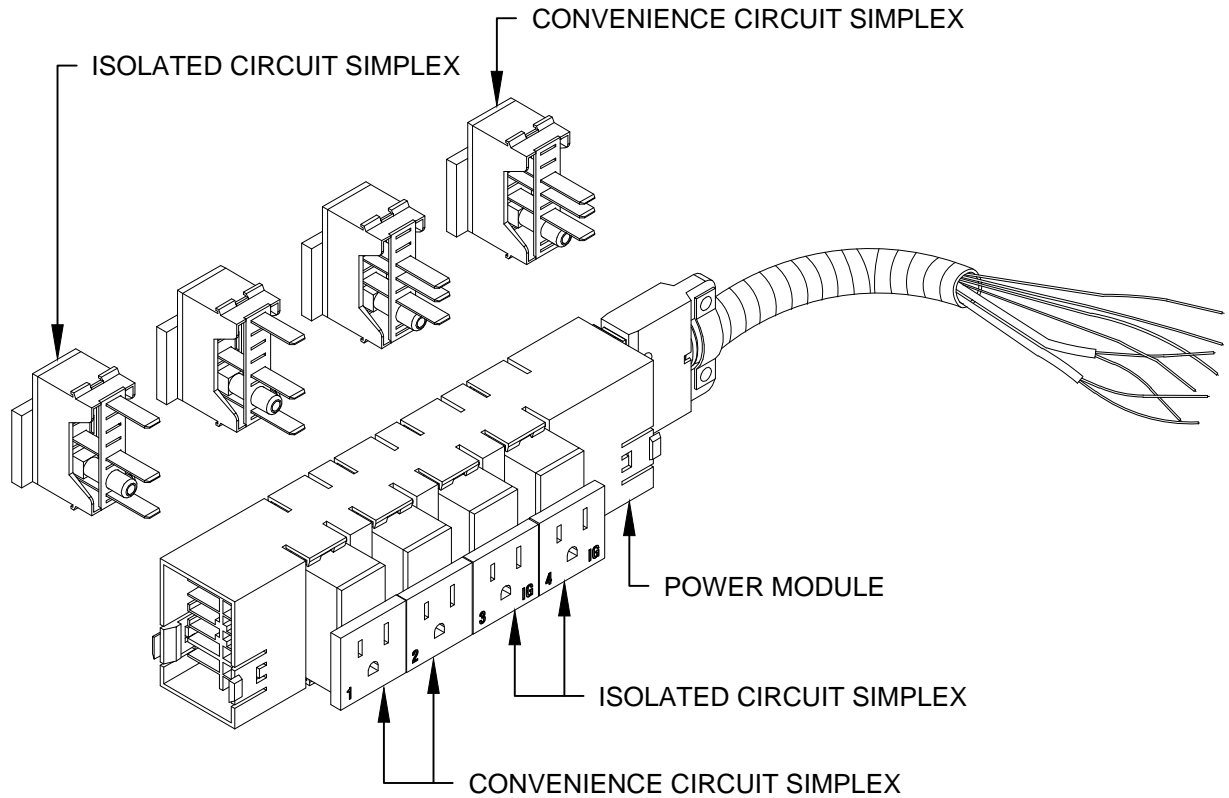

FIGURE 5

tools & hardware needed

	8540-1170 	8400-0144 		
Allen Key	1/4 -20 X 1/4 SS Screw (4X)	End Cap (2X)		

electrical components and specifications



Cable Cross Section 8 Wire 2+2

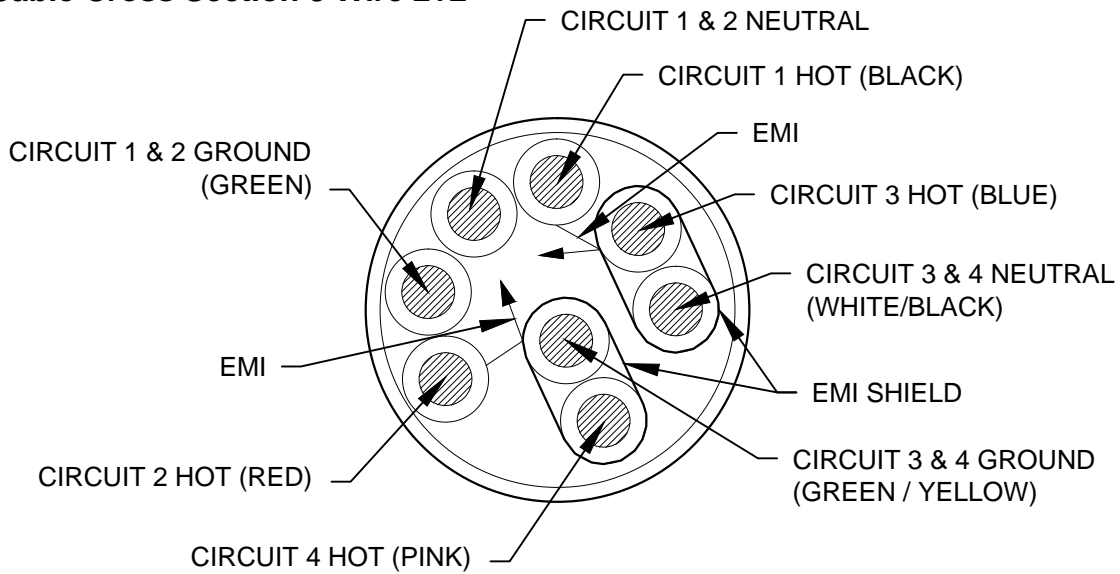

NOTE:

> All wires are 12 AWG in oval flex.

electrics / communications placement

The guidelines outline below should be followed when placing the electrics and communication. The tables show how much power modules and communication can you place on a certain width of panels.

	BASE		
	ELEC	COMM	
18		X	CANNOT BE SIDE BY SIDE
24	X		
24a		X	
30	X	X	
36	X	X	
42	X	X	
48	X	X	
54	X	X	
60	X	X	

	BELT			
	ELEC 4	ELEC 8	COMM	
18			X*	* - ON ONE SIDE ONLY
24			X	
30	X			CANNOT BE SIDE BY SIDE
30a			X	
36	X		X	
36a		X		CANNOT BE SIDE BY SIDE
42	X		X	
42a		X	X	
48	X		X	
48a		X	X	
54	X		X	
54a		X	X	
60	X		X	
60a		X	X	

NOTE:

- > Belt line moving tile cannot be put at the top of the panel.

electrical/data access and distribution

CEILING FEED POWER ENTRY

Power pole is accessible at 90 degree,
4-way & "T" connections.

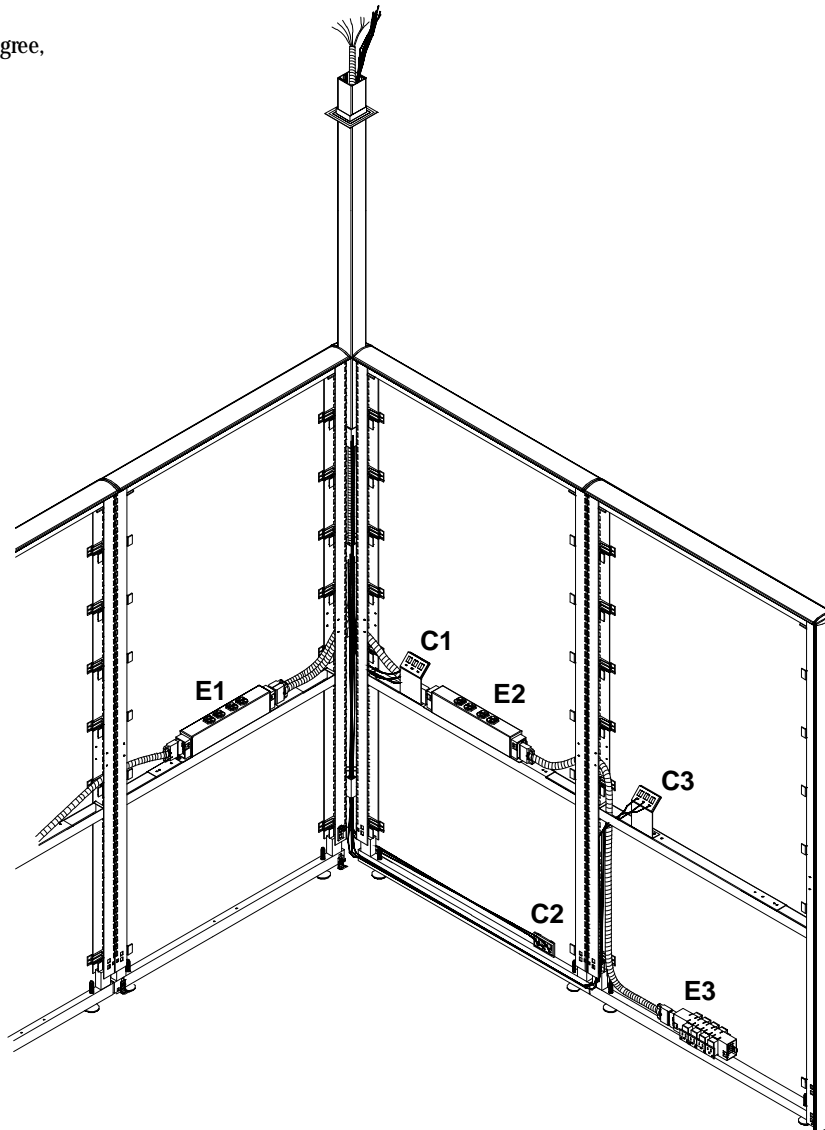

E3 - Raceway Electrical Module - 84 Wire System

E1, E2 - Beltline Electrical Module - 84 Wire System

C2 - Raceway Communication Kit

C1, C3 - Beltline Communication Kit

NOTE:

> It is not necessary to remove furniture (e.g. surfaces, surface supports, tiles) in order to reconfigure data and electrical runs.

electrical/data access and distribution (cont'd)

WALL / FLOOR POWER ENTRY

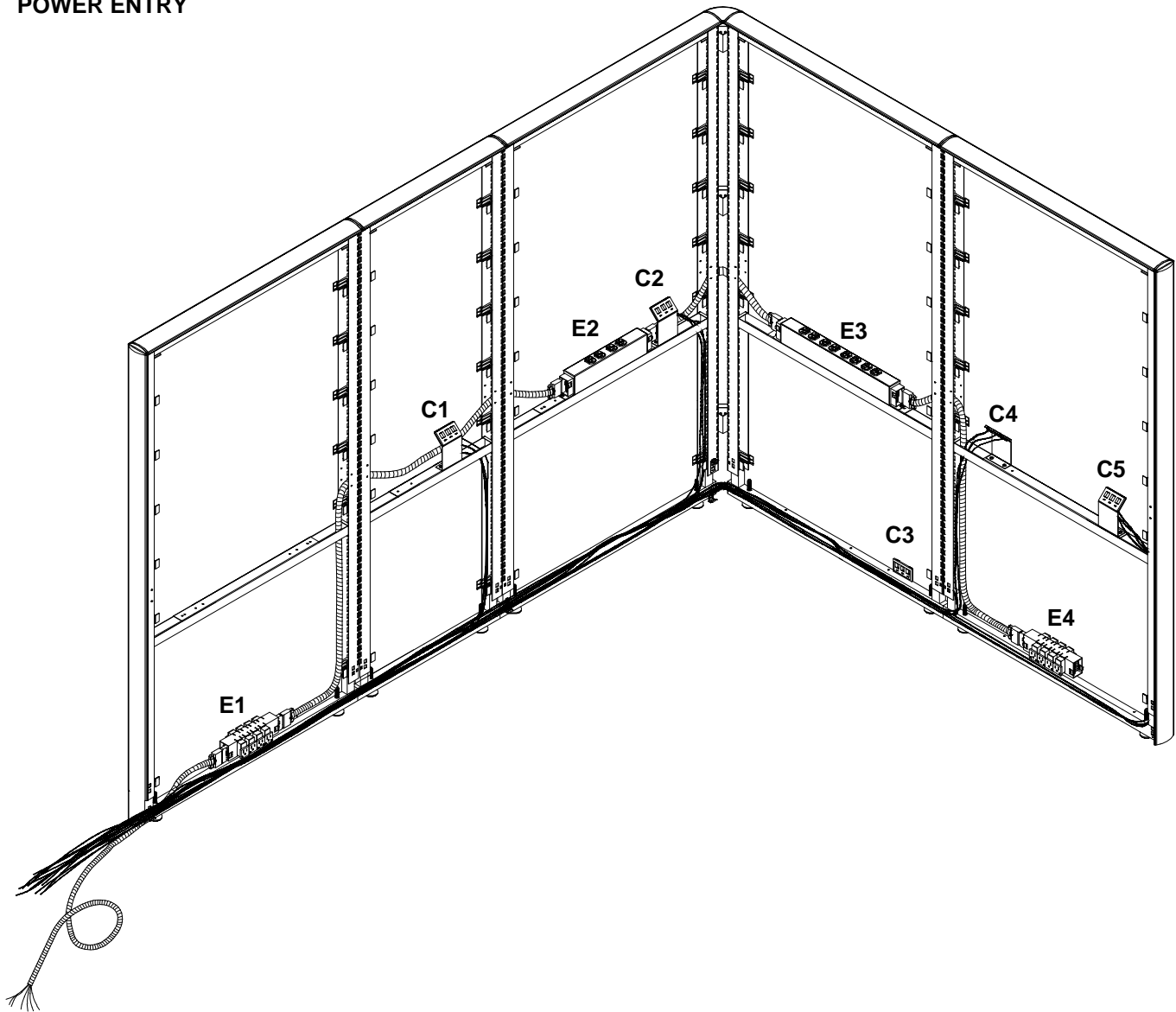

E1,E4 - Raceway Electrical Module - 84 Wire System

E2, E3 - Beltline Electrical Module - 84 Wire System

C3 - Raceway Communication Kit

C1, C2, C4, C5 - Beltline Communication Kit

NOTE:

- > It is not necessary to remove furniture (e.g. surfaces, surface supports, tiles) in order to reconfigure data and electrical runs.

harness calculation

ELECTRICAL CABLE LENGTH CALCULATION ON A STRAIGHT PANEL CONNECTION

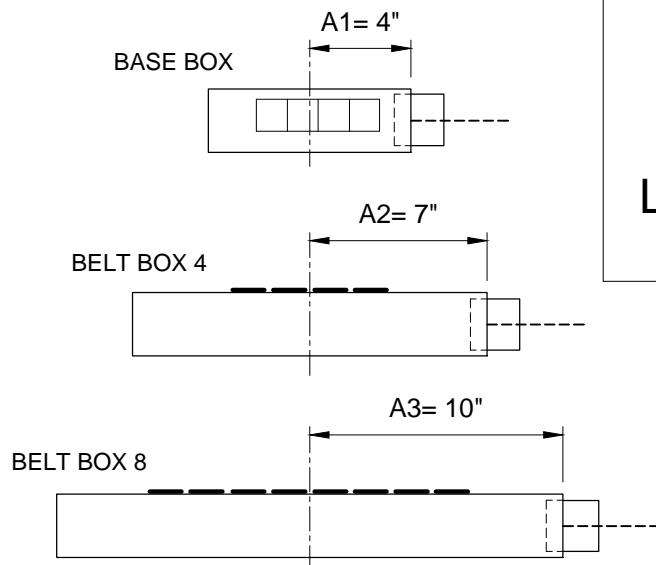
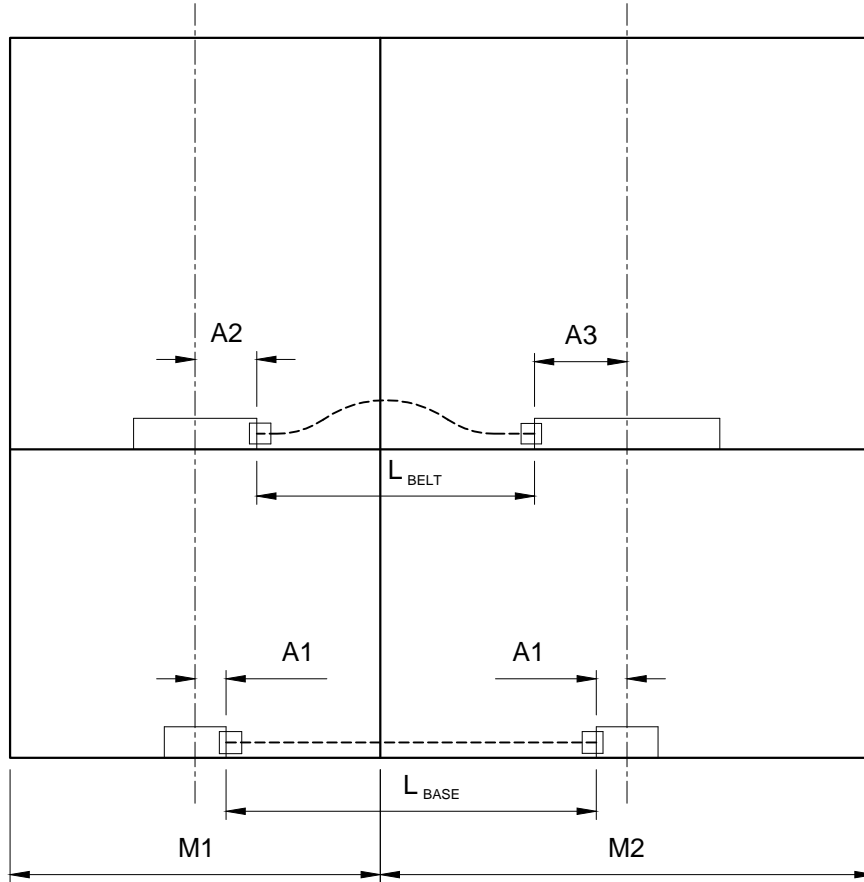

$$L_{BASE} = \frac{M1 + M2}{2} - 8"$$

$$L_{BELT} = \frac{M1 + M2}{2} + 3" - \frac{A2}{(A3)} - \frac{A2}{(A3)}$$

harness calculation (cont'd)

ELECTRICAL CABLE LENGTH CALCULATION ON A CORNER, T- OR X- PANEL CONNECTION

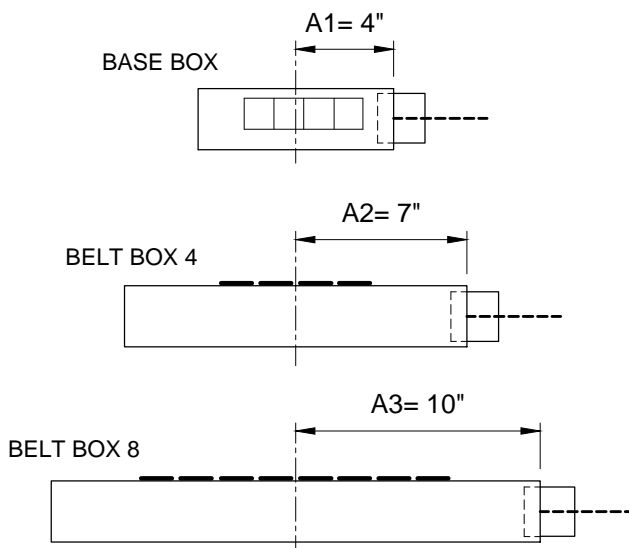
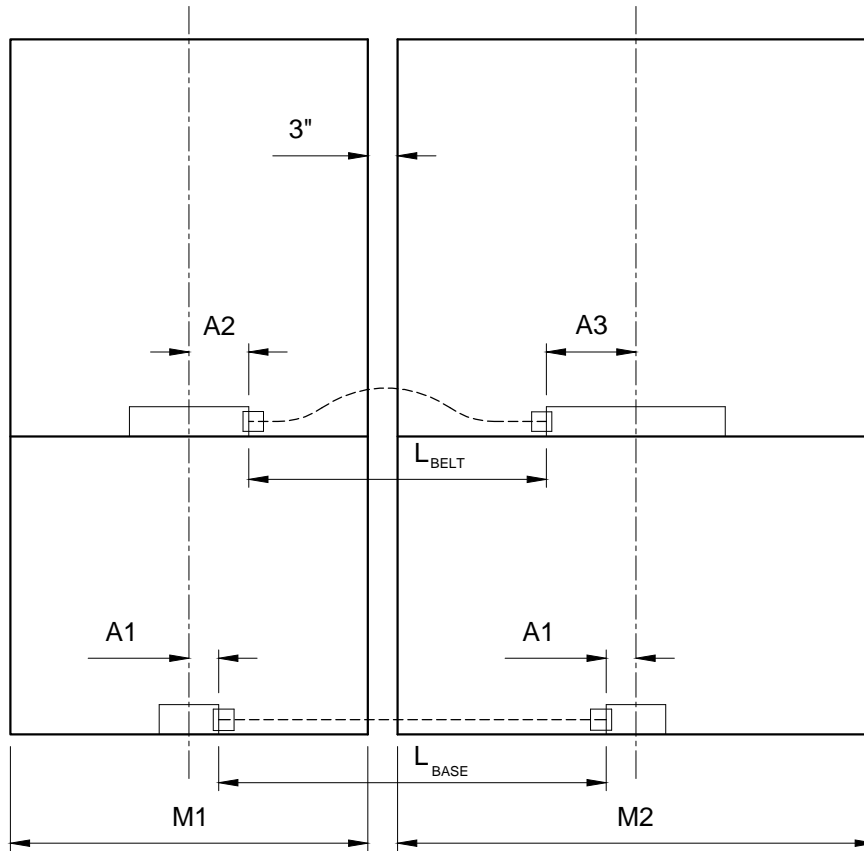

$$L_{\text{BASE}} = \frac{M1 + M2}{2} + 3" - 8"$$

$$L_{\text{BELT}} = \frac{M1 + M2}{2} + 6" - \frac{A2}{(A3)} - \frac{A2}{(A3)}$$

harness calculation (cont'd)

ELECTRICAL CABLE LENGTH CALCULATION ON A STRAIGHT PANEL CONNECTION

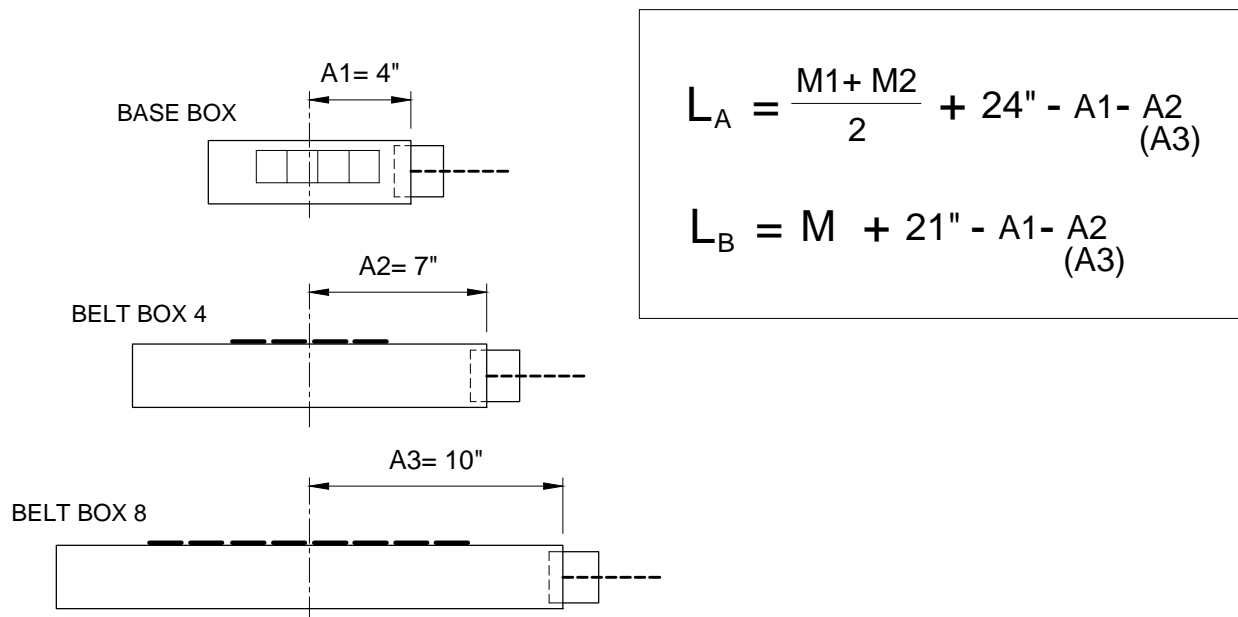
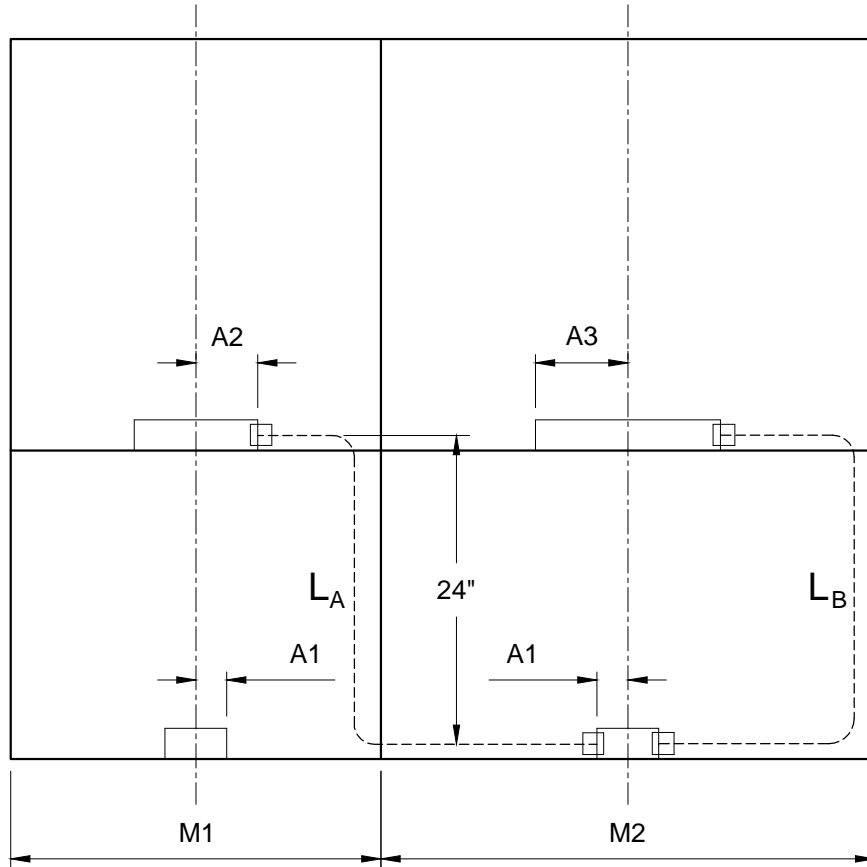

$$L_A = \frac{M1 + M2}{2} + 24" - A1 - A2 \quad (A3)$$

$$L_B = M + 21" - A1 - A2 \quad (A3)$$

harness calculation (cont'd)

ELECTRICAL CABLE LENGTH CALCULATION ON A CORNER, T- OR X- PANEL CONNECTION

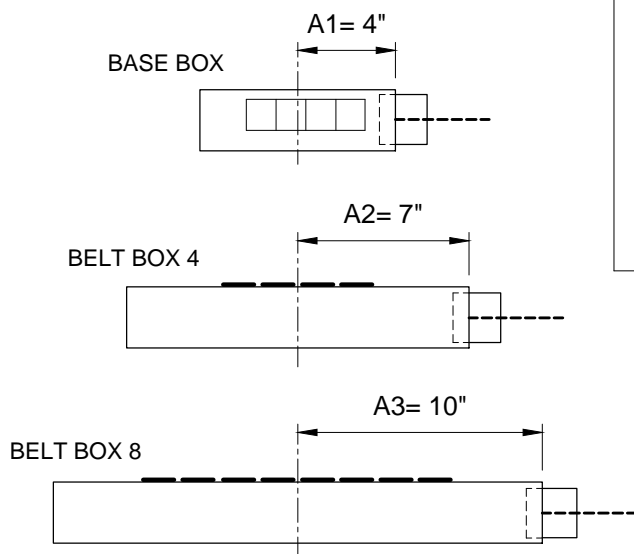
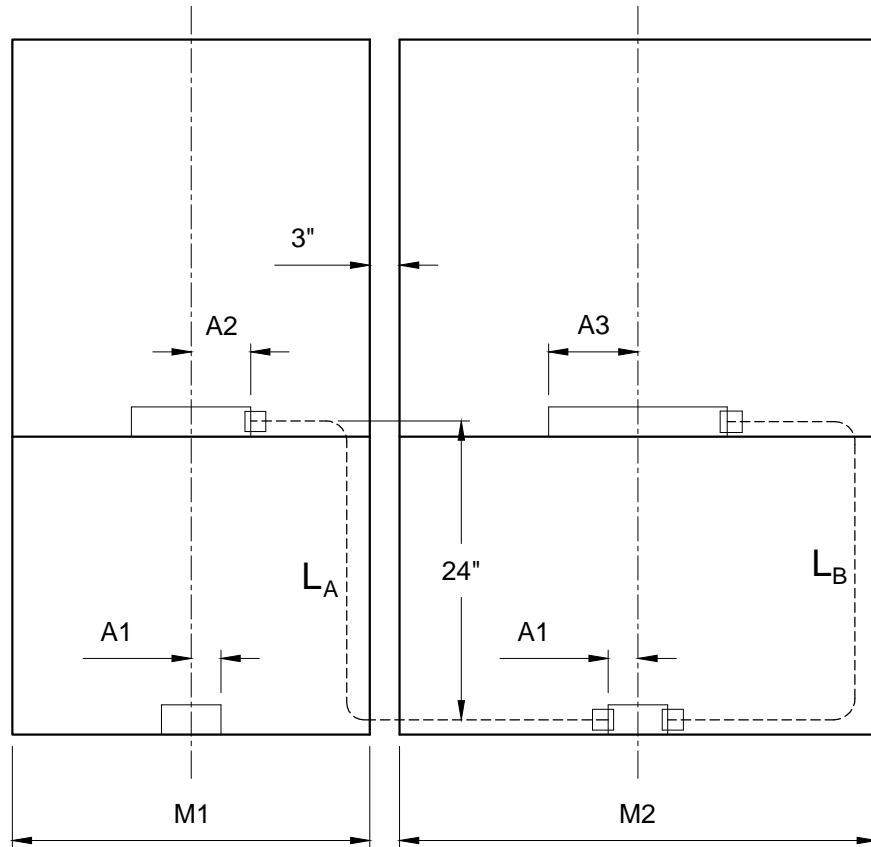

$$L_A = \frac{M1 + M2}{2} + 24" + 3" - A1 - A2 \quad (A3)$$

$$L_B = M + 21" - A1 - A2 \quad (A3)$$

panel electric installation

1. Sort all wires and power modules and lay them beside the panels that are to be electrified, (Figure 1).
2. Install vinyl electrical raceway holder with two flat head #10 screws (5/8-inch) provided, on the bottom of the panel frame, (Figure 2). Then slide the power module into the vinyl holder, (Figure 3).

FIGURE 1

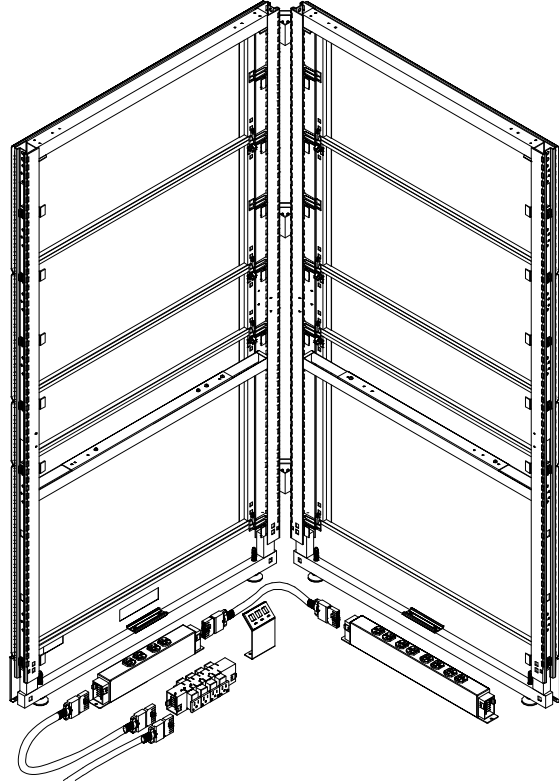

FIGURE 2

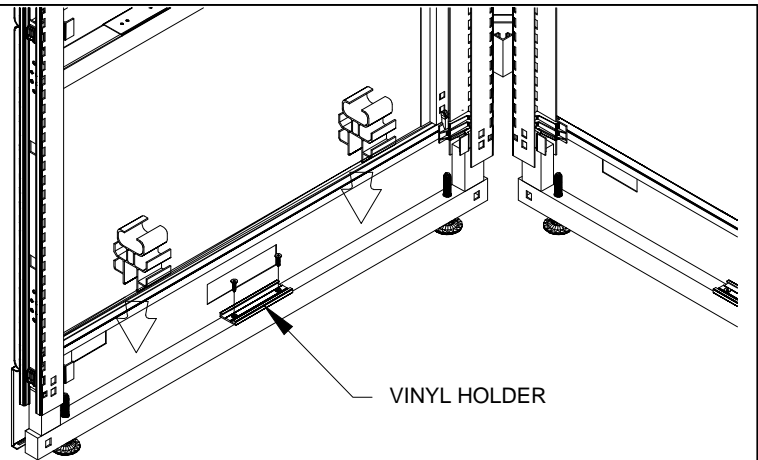
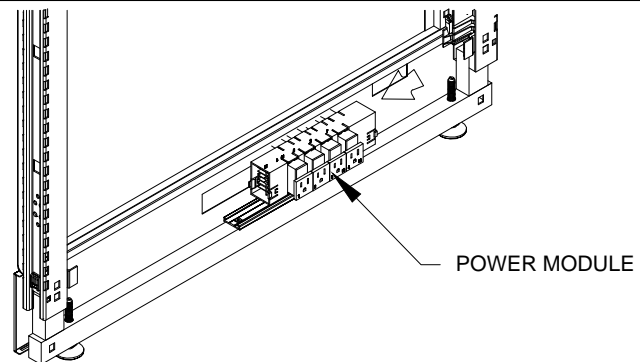
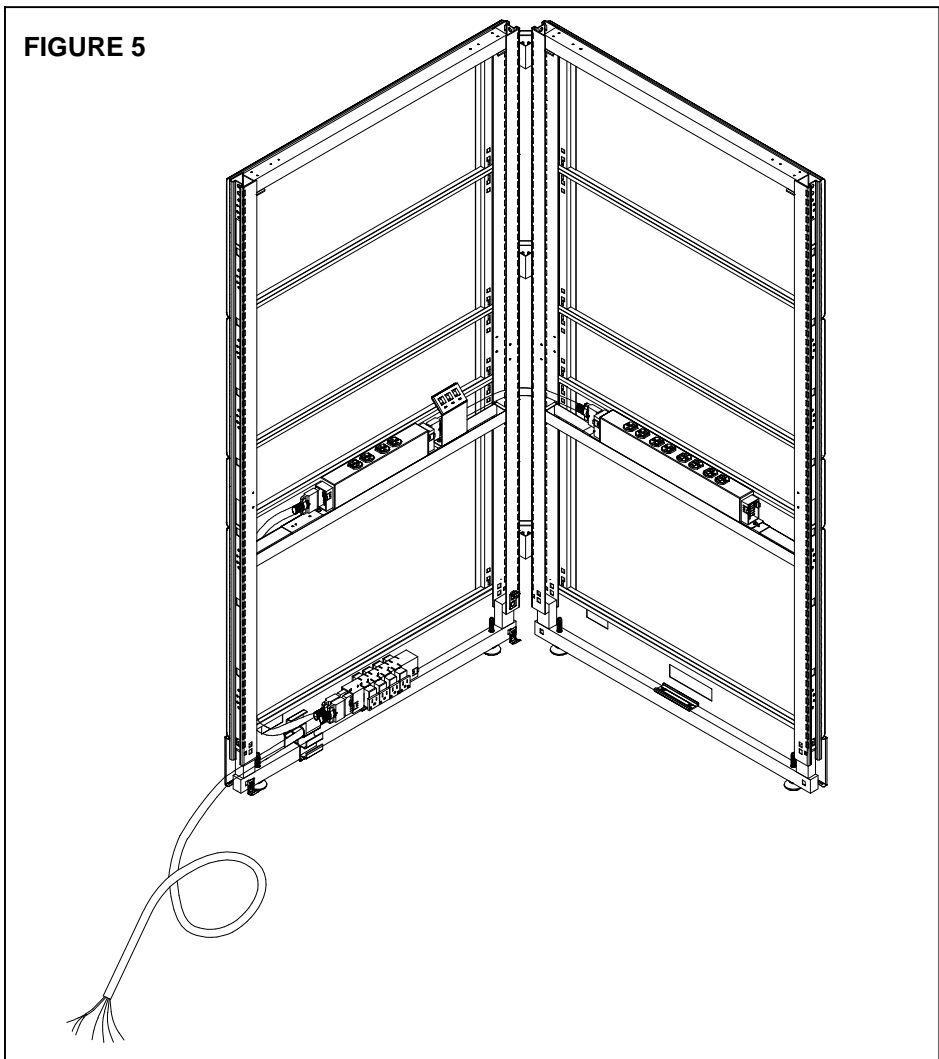
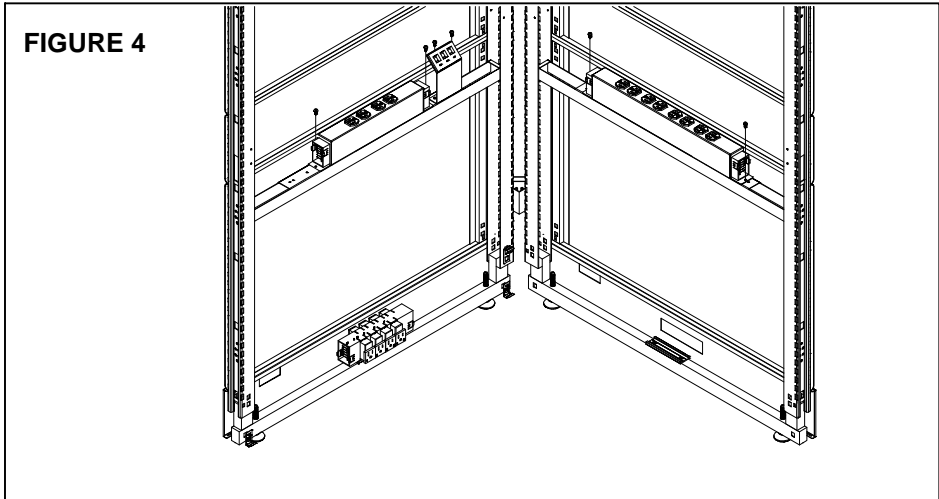

FIGURE 3







panel electric installation (cont'd)

3. Connect power modules and communication kits on the bar at the surface level, using two oval head #10 screws (11/16-inch) for each module or communication kit, (Figure 4).
4. Connect the correct electrical harnesses, (Figure 5).

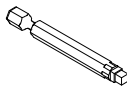

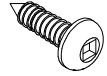
tools & hardware needed



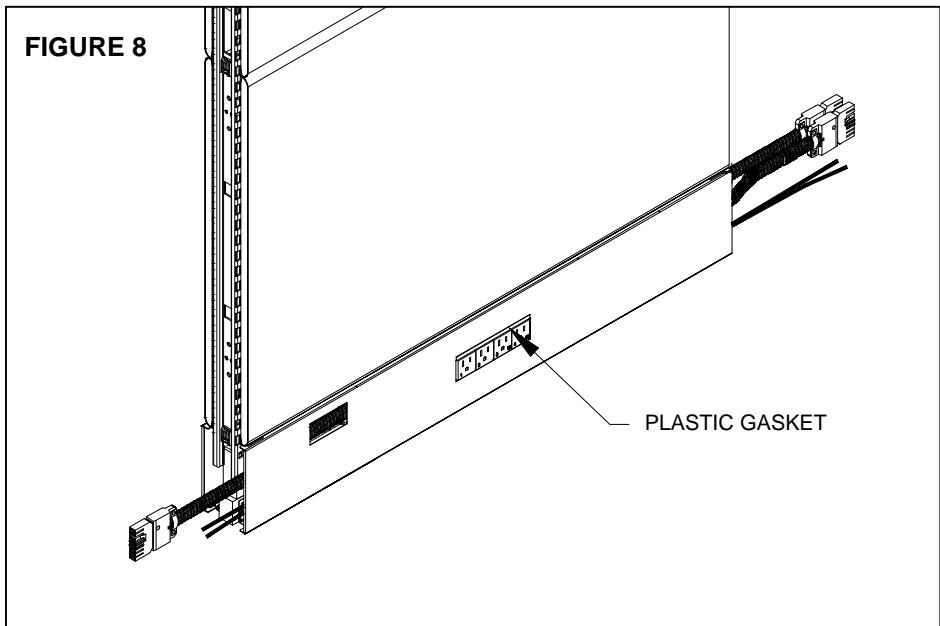
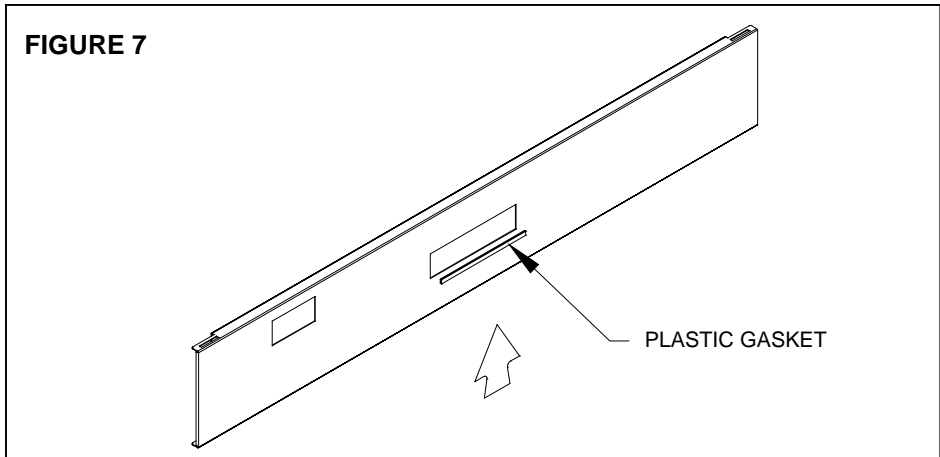
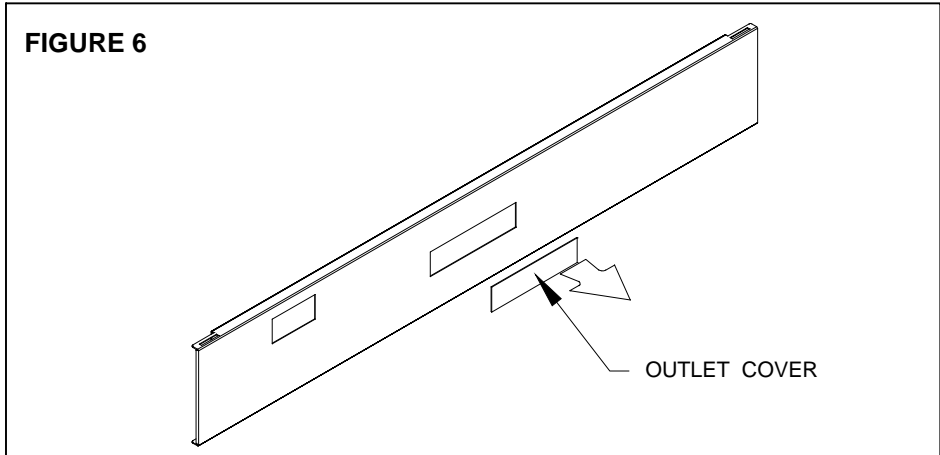

 <p>drill</p>	 <p>#3 Robertson bit</p>	 <p>#2 Robertson long bit</p>	 <p>2 per power module, 11/16" oval head screw</p>	 <p>2 per vinyl holder, 5/8" flat head screw</p>
--	--	--	---	---

panel electric installation (cont'd)

5. Pop-out the outlet cover located at the top of the raceway, (Figure 6).
6. Insert the plastic gasket on top edge of the outlet cover opening, (Figure 7).
7. Place the panel kick plate, (see panel kick plate installation).

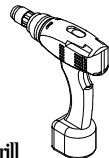
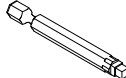

tools & hardware needed

 drill	 #3 Robertson bit	 #2 Robertson long bit	 2 per power module, 11/16" oval head screw	 2 per vinyl holder, 5/8" flat head screw	 1, plastic gasket
--	---	---	---	---	--

lay-in cable installation

1. Slide the power module into the vinyl holder.
2. Connect the electrical harnesses.
3. Lay the electrical harnesses and communication wires on the wire managers, (Figure 2).
4. Place the panel kick plate, (see panel kick plate installation).

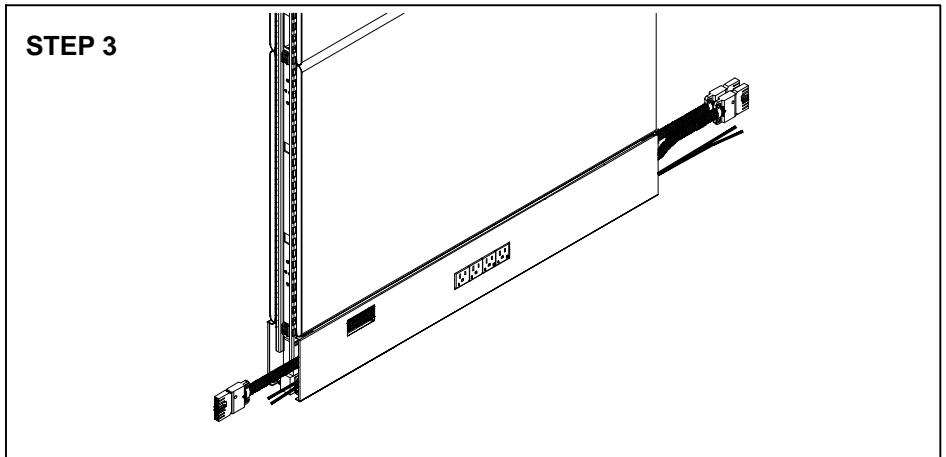
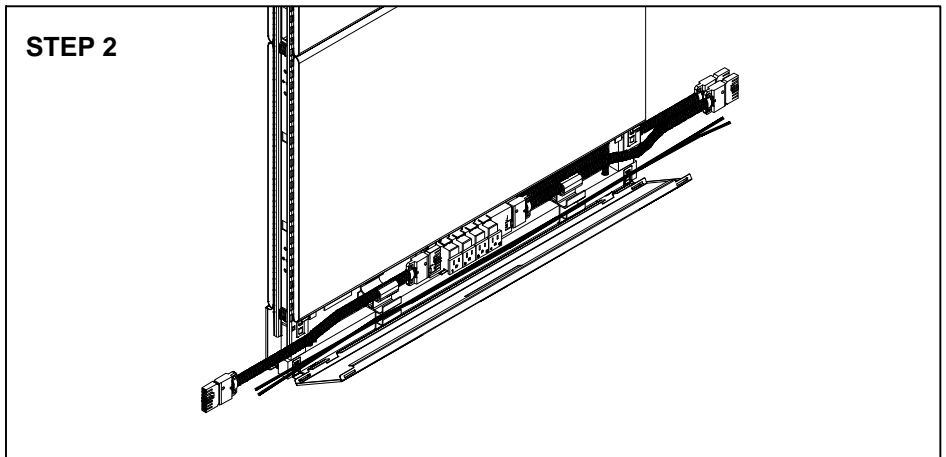
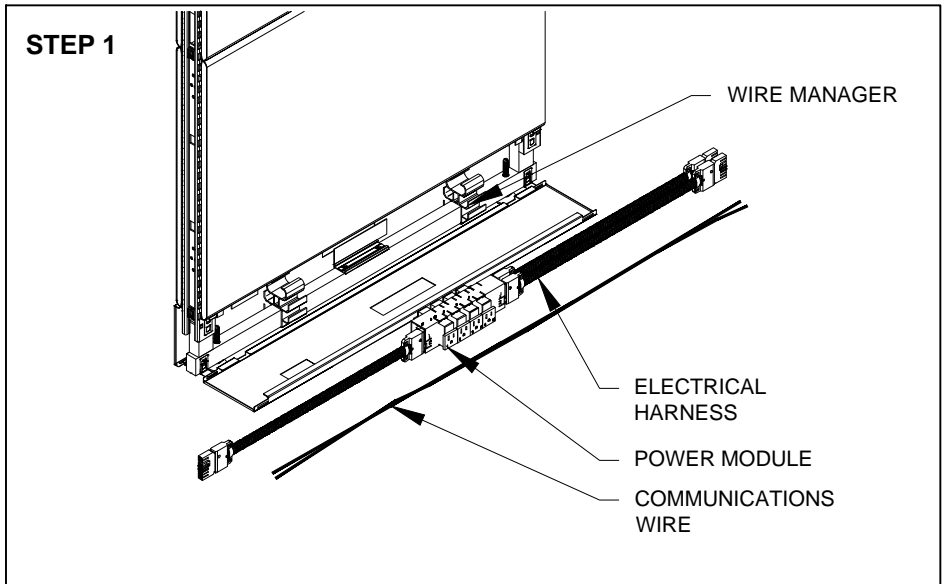

power pole installation

1. Inspect ceiling condition before beginning installation. If ceiling material is acoustical tile, remove tile above power pole before attaching the pole to the panel.
2. Attach 8-inches of the power pole to the panel frame with the two self-tapping screws supplied, (Figure 1).
3. Remove the clamp on the open end of the harness, so it can be fed through the panel connectors, (Figure 2).
4. Lay the cable in the power pole. Clip the two halves of the power pole together, (Figure 3).

FIGURE 1

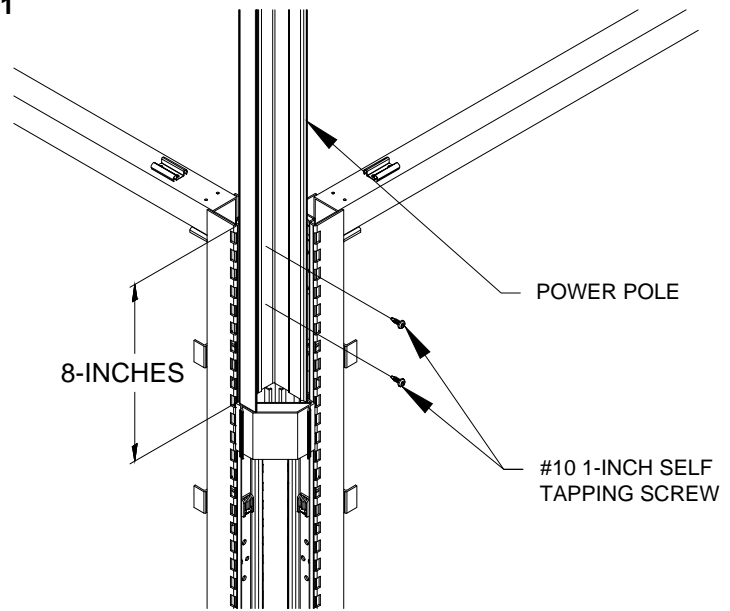

FIGURE 2

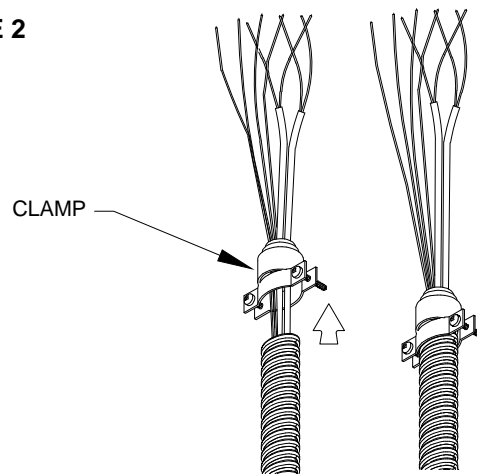
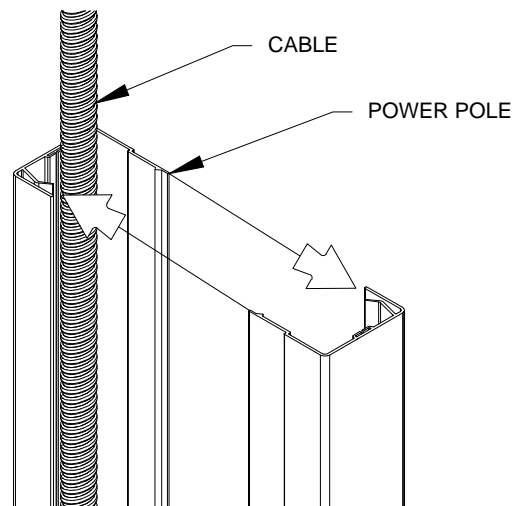
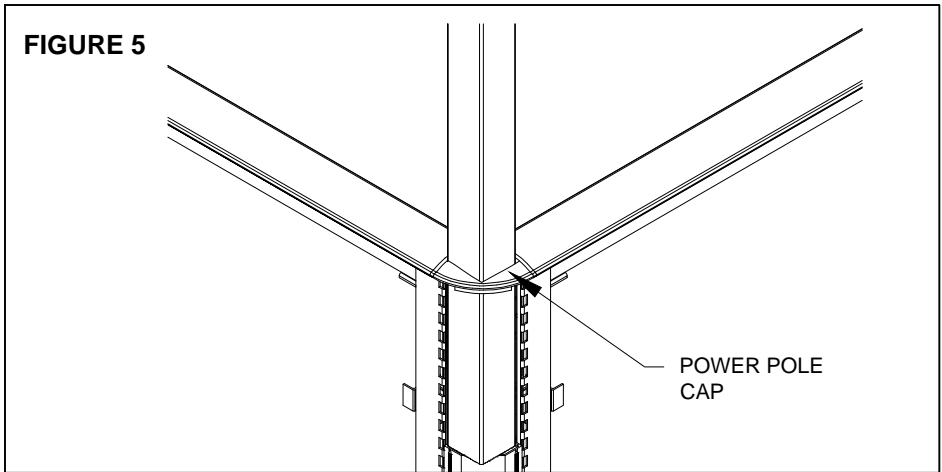
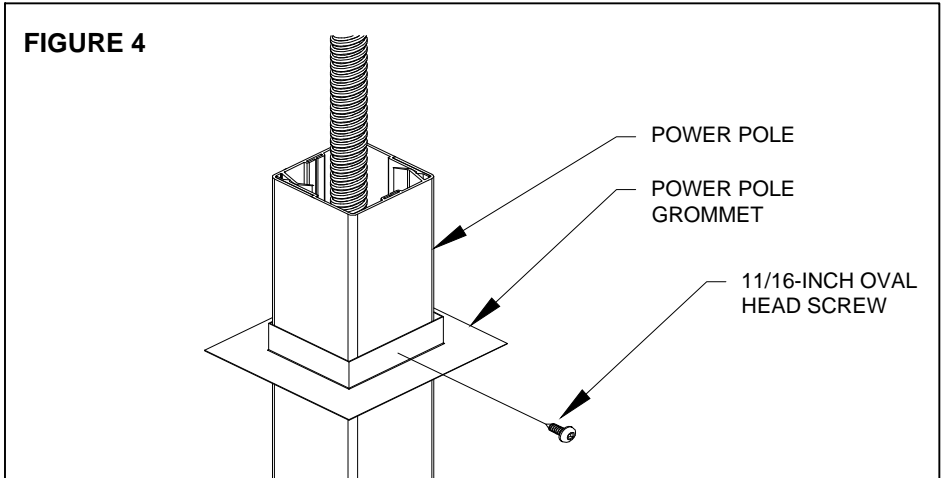

FIGURE 3





power pole installation (cont'd)



5. Slip the power pole grommet over the power pole; secure it with one screw, (Figure 4). Cut a hole through the ceiling above the power pole and reposition the tile in the ceiling.
6. Install the appropriate panel fillers, (Figure 5).

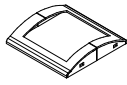
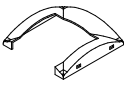
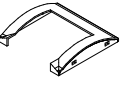

plastic caps with power pole hole

			
power pole straight cap	power pole cross cap	power pole T cap	power pole @-SSWd

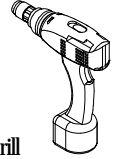
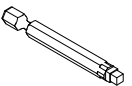
tools & hardware needed

			
drill	#3 Robertson bit	1, 11/16" oval head screw	2, #10 1" self tap screw

divided power pole installation

1. Inspect ceiling condition before beginning installation. If ceiling material is acoustical tile, remove tile above power pole before attaching the pole to the panel.
2. Attach 8-inches of the power pole to the panel frame with the two self-tapping screws supplied (Figure 1). Install the screws on an angle, (Figure 2).
3. Remove the clamp on the open end of the harness, so it can be fed through the panel connectors (Figure 3).

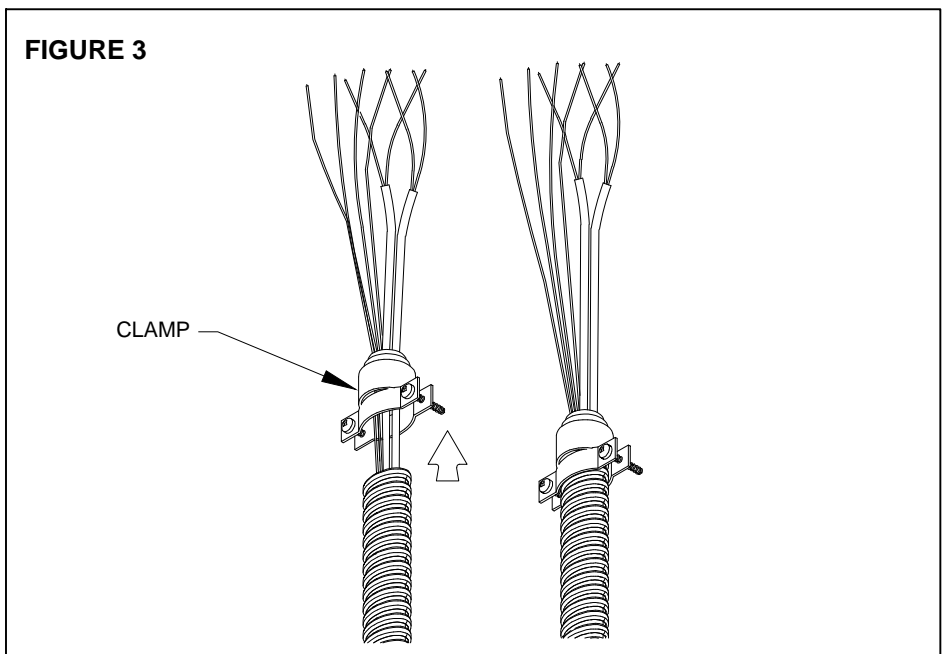
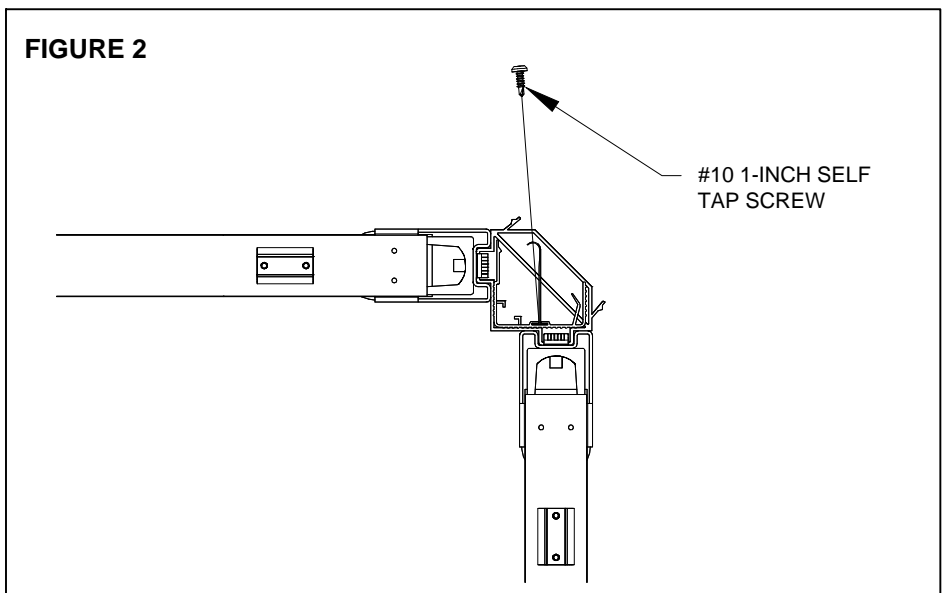
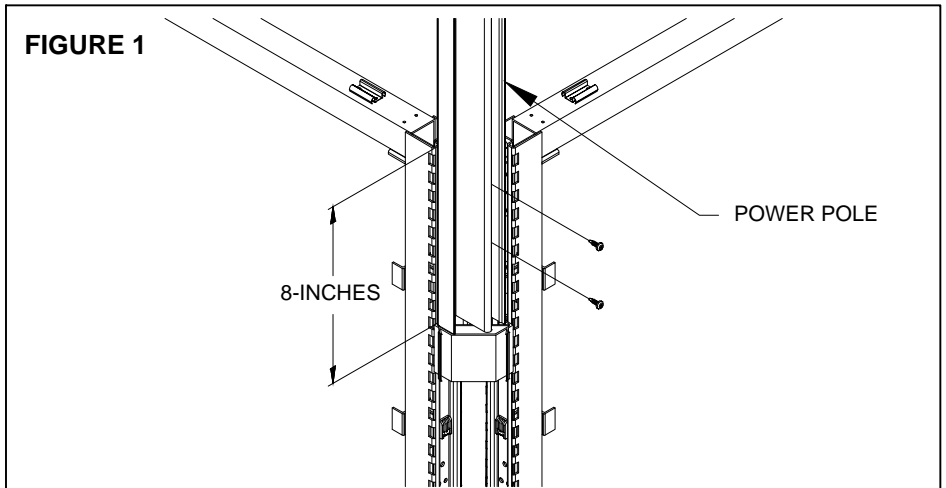



divided power pole installation (cont'd)

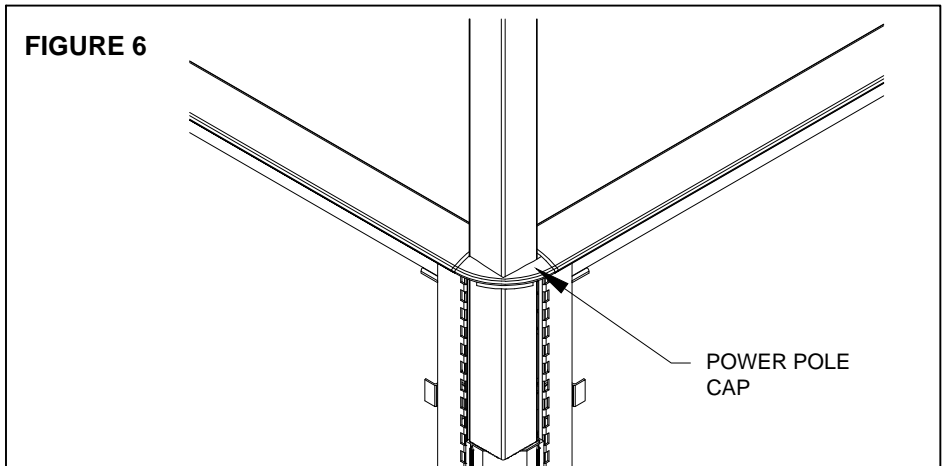
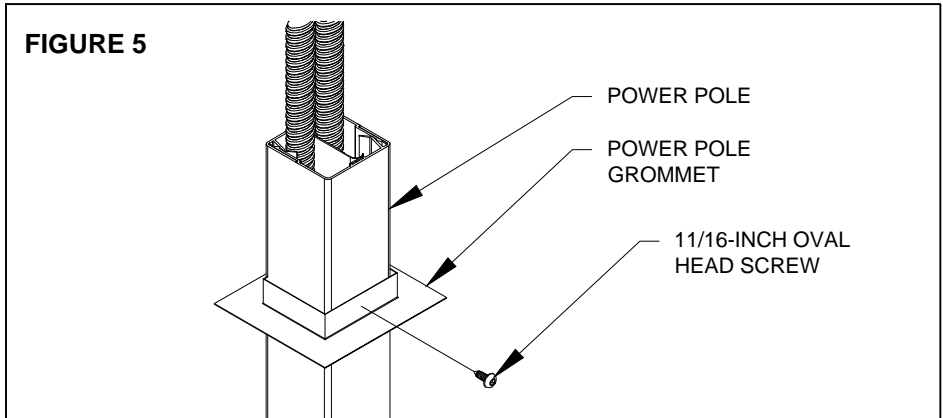
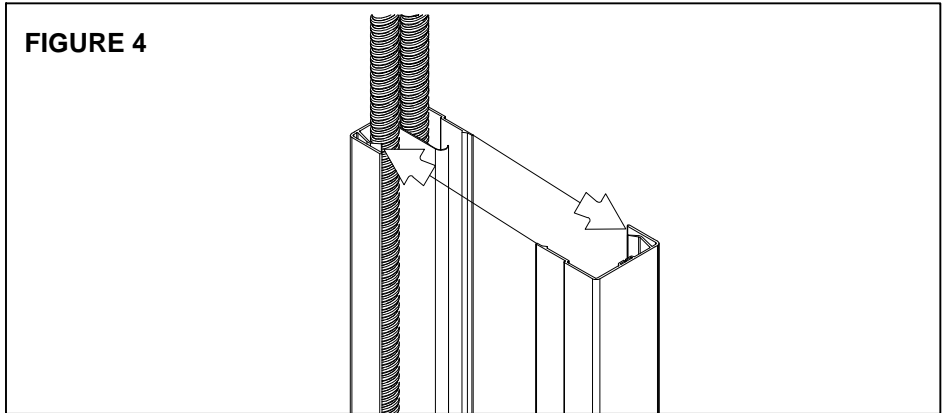

4. Lay the cables in the power pole. Clip the two halves of the power pole together (Figure 4).
5. Slip the power pole grommet over the power pole; secure it with one screw (Figure 5). Cut a hole through the ceiling above the power pole and reposition the tile in the ceiling.
6. Install the appropriate panel fillers (Figure 6)

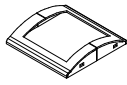
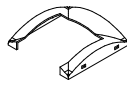
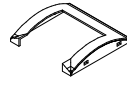

plastic cap with power pole hole

			
power pole straight cap	power pole cross cap	power pole T cap	power pole @-SSWd

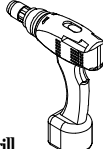
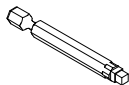
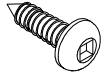
tools & hardware needed

			
drill	#3 Robertson bit	1, 11/16" oval head screw	2, #10 1" self tap screw

light wire management installation

1. Tuck the wire in the slot between tiles.
2. Secure the wire with plastic clips.
3. Loop the wire around the corner of a moving tile and put it under the apron.

FIGURE 1

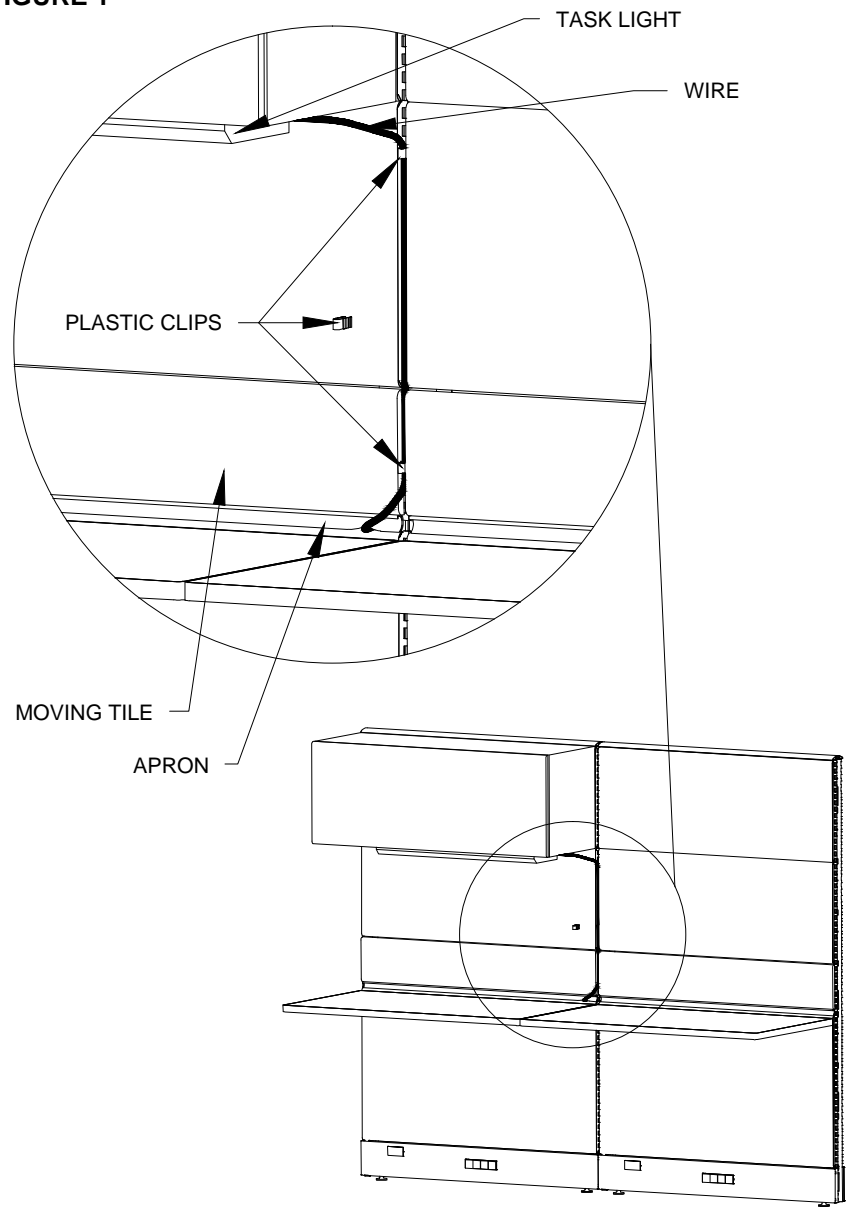

panel with monolithic tile disposal disassembly

1. Remove the aluminum top cap/trim (1), **Figure 1** and place it in the recycle bin containing steel materials.
2. Pull out the plastic panel trim inserts (2) of the aluminum top cap/trim and place them in the recycle bin containing plastic materials.
3. Detached the steel fasteners (3) from the frame (7) by removing the screws (4) holding them in place. Place them in the recycle bin containing steel materials.
4. Remove the steel raceways (5) and place them in the recycle bin containing steel materials.
5. Remove the tiles (6) from the frame (7), see page 61 of Cosmo Installation Guide (monolithic tile removal).
6. Lay the tiles (6) on the floor, **Figure 2**.
7. Remove the fabrics and place them in the waste bin.
8. Remove the rivets (8) using a hammer and a chisel. Place them in the recycle bin containing steel materials.
9. Remove the horizontal tile steel frame (9) using a pry and place it in the recycle bin containing steel materials.

Continued on the next page >>

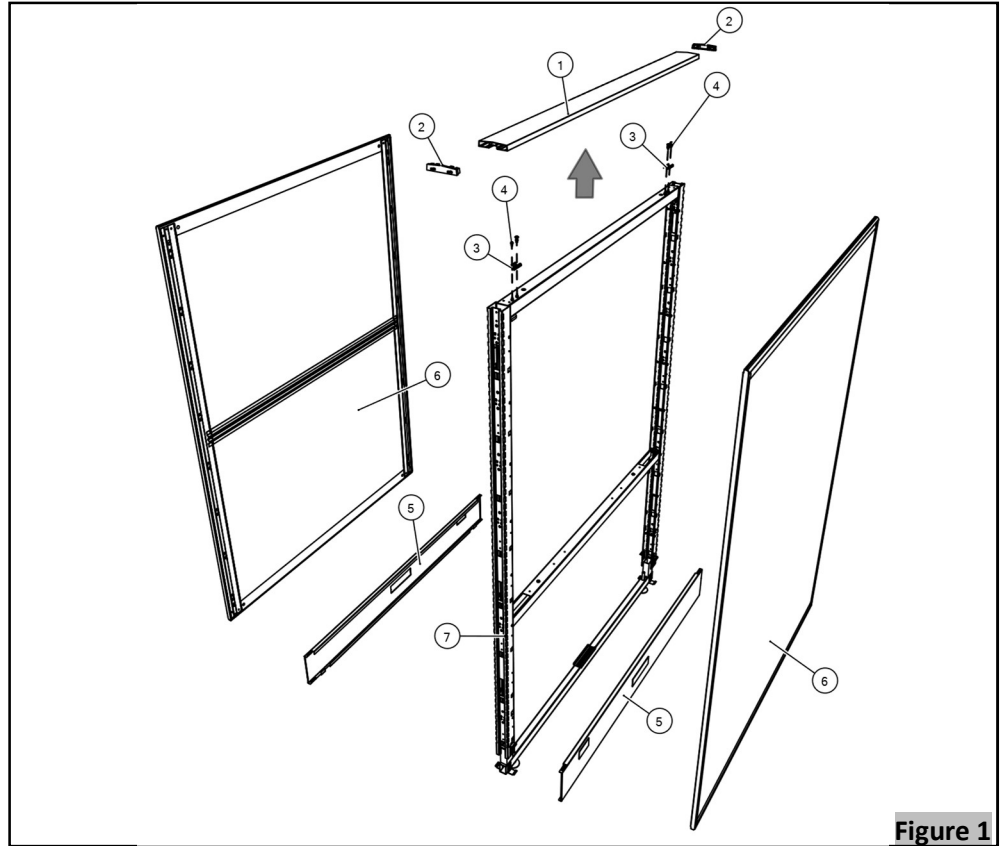

Figure 1

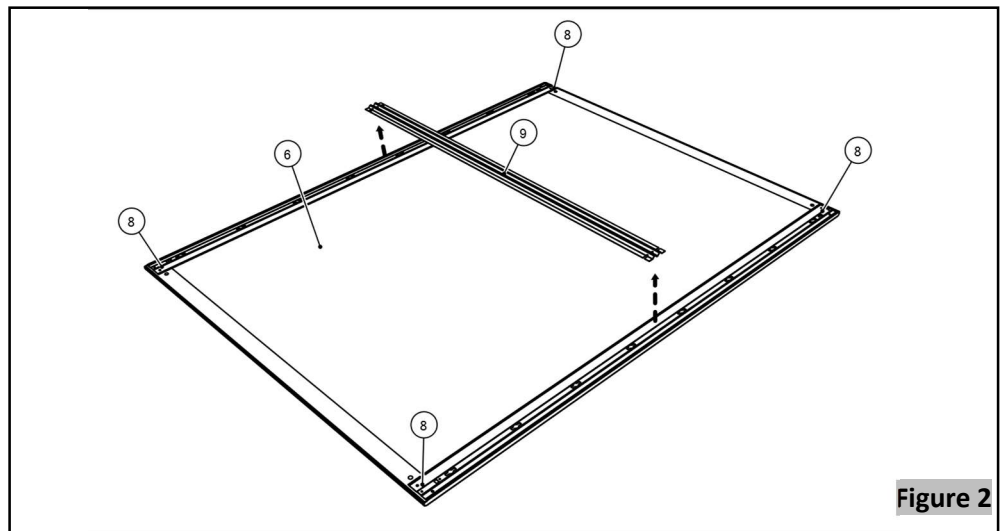
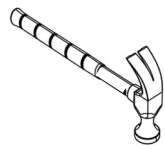
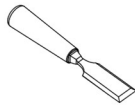
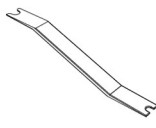

Figure 2

tools & hardware needed

					
Hammer	Chisel	Pry			

panel with monolithic tile disposal disassembly

- 10.** Pull out the vertical tile steel frames ⁽¹⁰⁾ of the honeycomb board ⁽¹²⁾, **Figure 3** and place them in the recycle bin containing steel materials.
- 11.** Pull out the horizontal tile steel frames ⁽¹¹⁾ of the honeycomb board ⁽¹²⁾ and place them in the recycle bin containing steel materials.
- 12.** Place the honeycomb board in the waste bin.
- 13.** Remove the screws ⁽¹³⁾ of the steel frame ⁽⁷⁾, **Figure 4** and place them in the recycle bin containing steel materials.
- 14.** Detach the plastic electric box holder ⁽¹⁴⁾ of the steel frame ⁽⁷⁾ by removing the screws ⁽¹⁵⁾ holding it in place. Place the electric box holder in the recycle bin containing plastic materials and the screws in the recycle bin containing steel materials.
- 15.** Detached the steel fasteners ⁽¹⁶⁾ of the steel frame ⁽⁷⁾ and place them in the recycle bin containing steel materials.
- 16.** Unscrew the glides ⁽¹⁷⁾ of the steel frame and place them in the recycle bin containing steel materials.
- 17.** Place the steel frame ⁽⁷⁾ in the recycle bin containing steel materials.

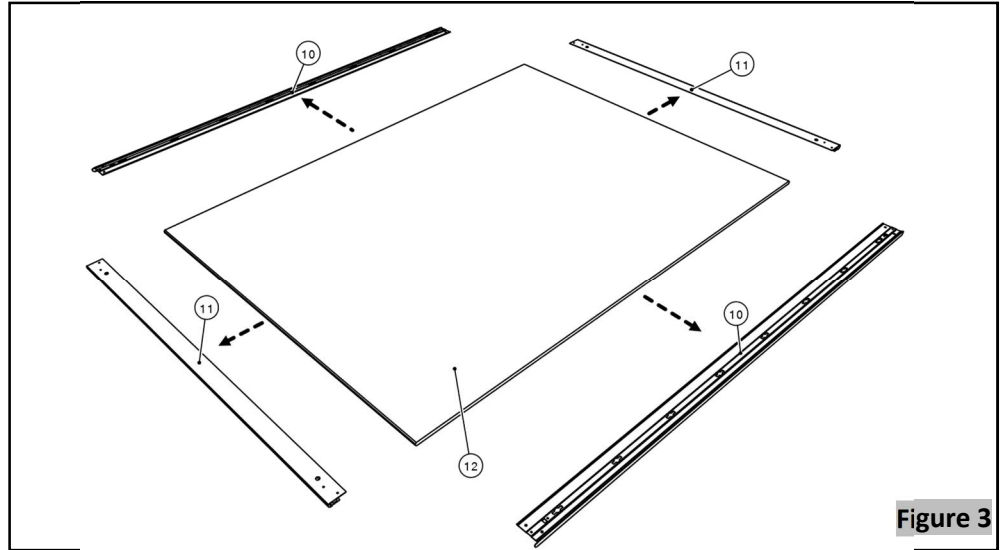

Figure 3

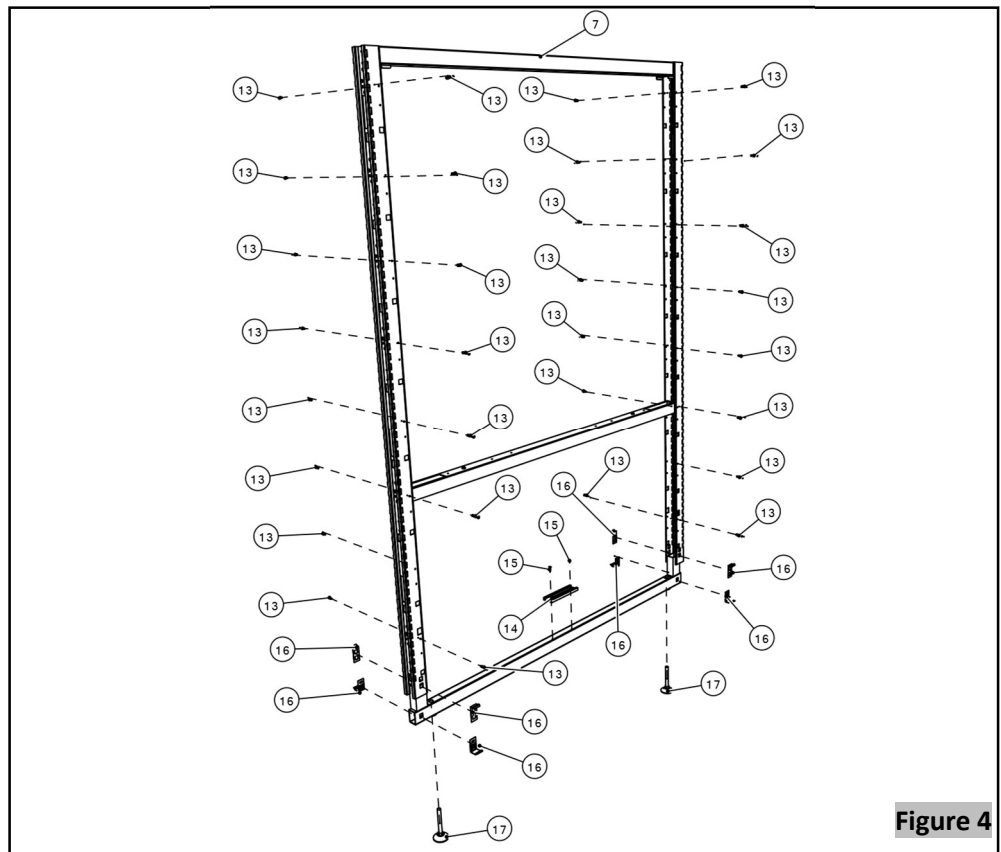



Figure 4

tools & hardware needed

					
Drill	Robertson # 2				

tayco®



Cosmo products consist of Steel and Aluminum which are 100% recyclable and visually identifiable. We encourage you to sell, donate, re-purpose or recycle or products. Disassembly of the product can be done by following the installation instructions in reverse.

tayco.com

1019